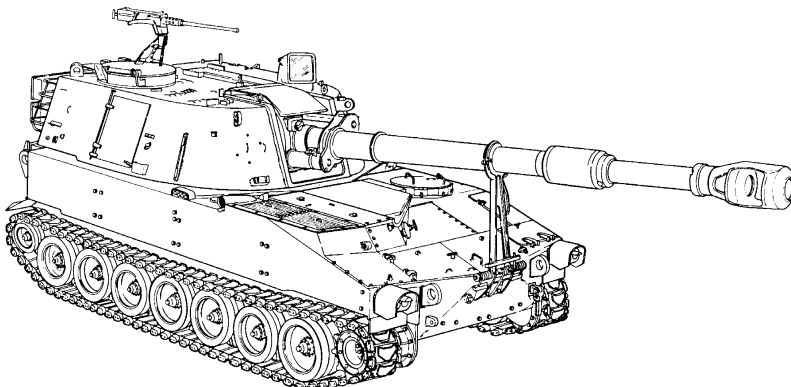


DEPARTMENT OF THE ARMY  
TECHNICAL MANUAL

**UNIT MAINTENANCE MANUAL  
FOR  
CAB, ARMAMENT, SIGHTING  
AND FIRE CONTROL, ELEVATING  
AND TRAVERSING SYSTEMS  
AND ASSOCIATED COMPONENTS  
HOWITZER, MEDIUM, SELF-PROPELLED  
155MM**

**M109A2 (2350-01-031-0586)(EIC:3EZ)  
M109A3 (2350-01-031-8851)(EIC:3E2)  
M109A4 (2350-01-277-5770)(EIC:3E8)  
M109A5 (2350-01-281-1719)(EIC:3E7)**



**PREVENTIVE MAINTENANCE  
CHECKS AND SERVICES (PMCS) 2-21**

**TROUBLESHOOTING 3-1**

**CAB HYDRAULICS 6-1**

**RAMMER SYSTEM 7-1**

**CAB ELECTRICAL SYSTEM 8-1**

**FIRE CONTROL 18-1**

**PURGING AND CHARGING 19-1**

**MAINTENANCE ALLOCATION  
CHART (MAC) B-1**

DISTRIBUTION STATEMENT A: Approved for public release, distribution is unlimited.

Copyright © 1994 BAE Systems Land & Armaments, L.P. Unlimited Government Rights.

---

**HEADQUARTERS, DEPARTMENT OF THE ARMY  
DECEMBER 1993**



**WARNING****CARBON MONOXIDE POISONING CAN BE DEADLY**

Carbon monoxide is a colorless, odorless, deadly poisonous gas, which, when breathed, deprives the body of oxygen and causes suffocation. Exposure to air contaminated with carbon monoxide produces symptoms of headache, dizziness, loss of muscular control, apparent drowsiness, coma, permanent brain damage, or even death from severe exposure.

Carbon monoxide occurs in the exhaust fumes of fuel-burning heaters and internal-combustion engines and becomes dangerously concentrated under conditions of inadequate ventilation. The following precautions must be observed to ensure the safety of personnel whenever the personnel heater, main, or auxiliary engine of any vehicle is operated for maintenance purposes or tactical use.

Do not operate heater or engine of vehicle in an enclosed area unless it is adequately ventilated.

Do not drive any vehicle with inspection plates, cover plates, or engine compartment doors removed unless necessary for maintenance purposes.

Be alert at all times during vehicle operation for exhaust odors and exposure symptoms. If either are present, immediately ventilate personnel compartments. If symptoms persist, remove affected personnel from vehicle and treat as follows: expose to fresh air; keep warm; do not permit physical exercise; and if necessary, administer artificial respiration.

**THE BEST DEFENSE AGAINST CARBON MONOXIDE  
POISONING IS ADEQUATE VENTILATION.**

**WARNING**

**RADIATION HAZARD**



**TRITIUM GAS (H<sub>3</sub>)**

#### Rules and Regulations

This item contains radioactive material. Control of this radioactive material is mandated by federal law. Immediately report any suspected lost or damaged items to your Radiation Protection Officer. If your Radiation Protection Officer can not be reached contact the TACOM-ACALA Safety Office.

Copies of the following rules and regulations are maintained at HQ, TACOM ACALA, Rock Island, IL 61299-7630. Copies may be requested or information obtained by contacting the ACALA Radiological Protection Officer (RPO), DSN 793-2965/2995/2962, Commercial (309) 782-2965/2995/2962. After duty hours, contact the staff duty officer through the operator at DSN 793-6001, Commercial (309) 782-6001.

1. 10 CFR Part 19 – Notices, Instructions and Report to Workers; Inspections.
2. 10 CFR Part 20 – Standards for Protection Against Radiation.
3. 10 CFR Part 21 – Reporting of Defects and Noncompliance.
4. NRC license, license conditions, and license application.

#### Safety Precautions

The radioactive material used in the M1A1 collimator and the M140 alinement device is tritium gas (H<sub>3</sub>) sealed in pyrex tubes. These sources illuminate the instrumentation for night operations. Tampering with or removing the source in the field is prohibited by Federal Law. They pose no significant hazard when intact. However, if an M1A1 collimator or an M140 alinement device is discovered to be broken, damaged, or defective, the following procedures will be followed:

1. Evacuate to a safe distance upwind and cordon off immediate area around device.
2. Immediately notify the Installation Radiation Protection Officer (RPO) and the Installation Safety Officer (SO).
3. All personnel will stand fast at the safe area until released by the RPO or the SO.
4. Follow the RPO's instruction for decontamination so as to avoid excess spread of tritium contamination.
5. Personnel exposed to tritium will notify medical personnel.

**WARNING****RADIATION HAZARD****TRITIUM GAS (H<sub>3</sub>)**

Rules and Regulations (Cont)

**Identification**

Radioactive self-luminous sources are identified by means of radioactive warning labels (as above). These labels should not be defaced or removed, and should be replaced immediately when necessary. Refer to the local RPO or the ACALA RPO for instructions on handling, storage, or disposal.

**Storage**

When radioactively illuminated instruments are defective, notify unit maintenance. These items must be placed in a plastic bag (item 5, Appx D) and packaged in the shipping container. Spare equipment must be stored in the shipping container, as received, until installed on the weapon. Storage of these items is recommended to be in an outdoor shed-type storage or unoccupied building.

**WARNING**

- Do not use mineral spirits or paint thinner to clean the howitzer. Mineral spirits and paint thinners, are highly toxic and combustible. Prolonged breathing can cause dizziness, nausea, and even death. Do not use these materials.
- Avoid prolonged contact with cleaning solvents and adhesives. To prevent damage to eyes, skin, and lungs:
  - Always use cleaning solvents and adhesives in a well ventilated area.
  - Do not permit smoking.
  - Do not use near open flame.
  - Avoid contact with skin.
  - Wear gloves and eye protection.
- When removing and installing heavy items, make sure to have sufficient personnel and adequate lifting equipment. Equipment can cause serious injury if dropped.
- Ensure traverse area is clear prior to turning on hydraulic power.
- Never torque hydraulic lines or fittings when hydraulic system is pressurized. Damage to tubes and fittings could result in injury to personnel.
- Failure to aline reticle of M140 alinement device with reticles of M117/M117A2 panoramic telescope and M118A2/M118A3 elbow telescope using boresighting procedure could result in projectiles landing outside target area. Injury or death of friendly forces can result from firing with misaligned fire control equipment.
- Refer to FM 21–11, First Aid For Soldiers, for correct procedures to be taken if personnel are injured.
- Refer to TM 9–1300–206, Ammunition and Explosives Standards, for correct procedures involving the use of ammunition. Incorrect use of ammunition can cause serious injury or death.

**WARNING**

- Do not drop tank of compressed nitrogen gas. Do not tap nitrogen tank. Tank can explode when tapped or dropped. When using in confined areas, use extreme care; gas could cause suffocation.
- Make sure nitrogen cylinder contains dry nitrogen. Dry nitrogen tanks are marked with one or two black bands. Certain other gases can cause accumulator to explode, resulting in possible injury.
- Failure to close check valve on main accumulator and pressure regulator valve could result in injury from high pressure in hoses of nitrogen charging assembly and air pressure gage assembly.
- Failure to open safety-relief valve could result in injury from high pressure trapped in hoses of nitrogen charging assembly and air pressure gage assembly.
- Accumulator contains high pressure nitrogen. Use caution when handling and working with it.
- High pressure gas is used in charging the accumulators and fire control equipment. Do not exceed recommended psi when charging these components. Keep face and body clear of release valves. Failure to observe safety precautions may result in injury or death.

**WARNING**

**CHEMICAL AGENT RESISTANT COATING (CARC) PAINT**

- CARC paint contains isocyanate, a constituent that can cause respiratory effects during and after the application of the material. During the application of CARC paint, coughing, shortness of breath, pain on respiration, increased sputum, and chest tightness may occur. CARC paint also produces itching and reddening of the skin, a burning sensation of the throat and nose, and watering of the eyes.
- An allergic reaction may occur after initial exposure (ranging from a few days to a few months later), producing asthmatic symptoms including coughing, wheezing, tightness in the chest, or shortness of breath.
- The following precautions must be observed to ensure the safety of personnel when CARC paint is applied.
- For brush/roller painting in confined spaces, an airline respirator is required, unless an air sampling shows exposure to be below standards. If the air sampling is below standards, either chemical cartridge or airline respirators are required.
- Spot painters applying CARC paint by brush or roller must wear clothing and gloves affording full coverage.
- Do not use water, alcohol, or amine based solvents to thin or remove CARC paints. Use of these solvents with CARC paints can produce chemical reactions resulting in nausea, disease, burns, or severe illness to personnel.
- Do not use paint solvents to remove paint/coating from your skin.
- Mix paint/coating in a well ventilated mixing room or spraying area away from open flames. Personnel mixing paint/coating should wear eye protection.
- Use paint/coating with adequate ventilation.



CHANGE  
NO. 4

HEADQUARTERS  
DEPARTMENT OF THE ARMY  
WASHINGTON, D.C., 31 DECEMBER 2008

**UNIT MAINTENANCE MANUAL  
FOR  
CAB, ARMAMENT, SIGHTING AND FIRE CONTROL,  
ELEVATING AND TRAVERSING SYSTEMS, AND ASSOCIATED COMPONENTS  
HOWITZER, MEDIUM, SELF-PROPELLED,  
155MM**

**M109A2 (2350-01-031-0586) (EIC: 3EZ)**

**M109A3 (2350-01-031-8851) (EIC: 3E2)**

**M109A4 (2350-01-277-5770) (EIC: 3E8)**

**M109A5 (2350-01-281-1719) (EIC: 3E7)**

TM 9-2350-311-20-2, 24 December 1993, is changed as follows:

1. The purpose of this change is to update TM 9-2350-311-20-2.
2. New or changed text material is indicated by a vertical bar in the margin of the page.
3. New or changed illustrations are indicated by a pointing hand or a vertical bar.
4. Remove old pages and insert new pages as indicated below.

Remove pages

c and d  
A through C/(D blank)  
i and ii  
1-5 and 1-6  
1-11 and 1-12  
1-21 and 1-22  
2-5 and 2-6  
2-21 and 2-22  
2-31 and 2-32  
2-39 and 2-40  
2-45 and 2-46  
5-21 through 5-28  
5-41 and 5-42  
6-23 and 6-24  
7-3 and 7-4  
7-7 thru 7-10  
7-11 and 7-12  
10-1 through 10-4  
A-1 through A-4  
B-1 though B-20  
D-3 and D-4  
Index-1 and Index-2

Insert pages

c and d  
A through C/(D blank)  
i and ii  
1-5 and 1-6  
1-11 and 1-12  
1-21 and 1-22  
2-5 and 2-6  
2-21 and 2-22  
2-31 and 2-32  
2-39 and 2-40  
2-45 and 2-46  
5-21 through 5-28  
5-41 and 5-42  
6-23 and 6-24  
7-3 and 7-4  
7-7 thru 7-10  
7-11 and 7-12  
10-1 through 10-3/(10-4 blank)  
A-1 through A-4  
B-1 though B-20  
D-3 and D-4  
Index-1 and Index-2

**TM 9-2350-311-20-2**

2028-2 Sample and Blank

All 2028-2s

Front Cover/ Pin

Metric Chart/Pin

2028-2 Sample (Part I and Part II)

2028 (Part I and Part II)


Front Cover/Pin

Metric Chart/Pin

5. File this change sheet in front of the publication for reference purposes.

By Order of the Secretary of the Army:

GEORGE W. CASEY, JR.  
*General, United States Army*  
*Chief of Staff*

Official:  
  
JOYCE E. MORROW  
*Administrative Assistant to the*  
*Secretary of the Army*  
0800806

Distribution:

To be distributed in accordance with the initial distribution number (IDN) 371737 requirements for TM 9-2350-311-20-2.



CHANGE  
NO. 3

HEADQUARTERS  
DEPARTMENT OF THE ARMY  
WASHINGTON, D.C., 10 January 2000

UNIT MAINTENANCE MANUAL  
FOR  
CAB, ARMAMENT, SIGHTING AND FIRE CONTROL,  
ELEVATING AND TRAVERSING SYSTEMS, AND ASSOCIATED COMPONENTS  
HOWITZER, MEDIUM, SELF-PROPELLED,  
155MM

M109A2 (2350-01-031-0586) (EIC: 3EZ)  
M109A3 (2350-01-031-8851) (EIC: 3E2)  
M109A4 (2350-01-277-5770) (EIC: 3E8)  
M109A5 (2350-01-281-1719) (EIC: 3E7)

TM 9-2350-311-20-2, 24 December 1993, is changed as follows:

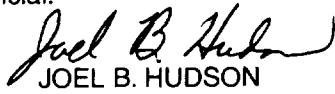
1. Remove old pages and insert new pages as indicated below.
2. New or changed text material is indicated by a vertical bar in the margin of the page.
3. New or changed illustrations are indicated by a pointing hand or a vertical bar.
4. All references made to SC 4910-95-CL-A72 are to be made to SC 4910-95-A72 in the manual.
5. All references made to SC 4910-95-CL-A74 are to be made to SC 4910-95-A74 in the manual.
6. All references made to SC 4931-95-CL-J54 are to be made to SC 4931-95-J54 in the manual.
7. All references made to SC 4933-95-CL-A06 are to be made to SC 4933-95-A06 in the manual.
8. All references made to SC 4933-95-CL-A12 are to be made to SC 4933-95-A12 in the manual.
9. All references made to SC 5180-95-CL-A12 are to be made to SC 4933-95-A12 in the manual.

Remove pages	Insert pages
i and ii	i and ii
2-17 and 2-18	2-17 and 2-18
3-5 and 3-6	3-5 and 3-6
3-21 and 3-22	3-21 and 3-22
3-71 and 3-72	3-71 and 3-72
6-23 and 6-24	6-23 and 6-24
7-3 through 7-6	7-3 through 7-6
7-11 through 7-16	7-11 through 7-16
11-7 through 11-10	11-7 through 11-10
12-5 and 12-6	12-5 and 12-6
14-7 through 14-14	14-7 through 14-14
14-17 through 14-20	14-17 through 14-20
14-23 through 14-30	14-23 through 14-30

By Order of the Secretary of the Army

DENNIS J. REIMER  
General, United States Army  
Chief of Staff

Official:

  
JOEL B. HUDSON

Administrative Assistant to the  
Secretary of the Army

9932202

DISTRIBUTION: To be distributed in accordance with the initial distribution number (IDN) 371737 requirements for TM 9-2350-311-20-2.



CHANGE

NO. 2

HEADQUARTERS  
DEPARTMENT OF THE ARMY  
WASHINGTON, D.C., 31 July 1998

UNIT MAINTENANCE MANUAL  
FOR  
CAB, ARMAMENT, SIGHTING AND FIRE CONTROL,  
ELEVATING AND TRAVERSING SYSTEMS, AND ASSOCIATED COMPONENTS  
HOWITZER, MEDIUM, SELF-PROPELLED,  
155MM

M109A2 (2350-01-031-0586) (EIC: 3EZ)

M109A3 (2350-01-031-8851) (EIC: 3E2)

M109A4 (2350-01-277-5770) (EIC: 3E8)

M109A5 (2350-01-281-1719) (EIC: 3E7)

TM 9-2350-311-20-2, 24 December 1993, is changed as follows:

1. Remove old pages and insert new pages as indicated below.
2. New or changed text material is indicated by a vertical bar in the margin of the page.
3. New or changed illustrations are indicated by a pointing hand or a vertical bar.

Remove pages	Insert pages
a and b	a and b
i through iv	i through iv
1-3 through 1-8	1-3 through 1-8
1-19 and 1-20	1-19 and 1-20
2-5 through 2-8	2-5 through 2-8
2-15 through 2-18	2-15 through 2-18
2-29 and 2-30	2-29 and 2-30
2-35 and 2-36	2-35 and 2-36
2-39 through 2-46	2-39 through 2-46
3-3 through 3-8	3-3 through 3-8
3-11 and 3-12	3-11 and 3-12
3-15 and 3-16	3-15 and 3-16
3-21 through 3-28	3-21 through 3-28
3-33 and 3-34	3-33 and 3-34
3-37 through 3-40	3-37 through 3-40
None	3-40.1 and 3-40.2
3-47 through 3-50	3-47 through 3-50
3-53 through 3-58	3-53 through 3-58
3-69 and 3-70	3-69 and 3-70
3-79 and 3-80	3-79 and 3-80



Remove pages

None  
3-81 and 3-82  
3-85 and 3-86  
3-89 through 3-100  
5-1 and 5-2  
5-7 through 5-14  
5-19 through 5-28  
5-31 through 5-42  
None  
5-43 through 5-46  
5-51 and 5-52  
None  
6-1 through 6-4  
6-7 through 6-10  
6-13 through 6-20  
6-23 and 6-24  
6-29 through 6-38  
6-43 and 6-44  
None  
6-45 through 6-54  
6-77 and 6-78  
6-81/(6-82 blank)  
7-3 through 7-10  
None  
7-11 through 7-14  
7-17/(7-18 blank)  
8-11 through 8-14  
8-27 through 8-30  
8-37 through 8-42  
8-45 and 8-46  
8-59 and 8-60  
8-67 through 8-72  
8-75 and 8-76  
9-7 through 9-16  
11-1 and 11-2  
11-9 and 11-10  
None

Insert pages

3-80.1/(3-80.2 blank)  
3-81 and 3-82  
3-85 and 3-86  
3-89 through 3-98  
5-1 and 5-2  
5-7 through 5-14  
5-19 through 5-28  
5-31 through 5-42  
5-42.1/(5-42.2 blank)  
5-43 through 5-46  
5-51 and 5-52  
5-55 through 5-58  
6-1 through 6-4  
6-7 through 6-10  
6-13 through 6-20  
6-23 and 6-24  
6-29 through 6-38  
6-43 and 6-44  
6-44.1 through 6-44.6  
6-45 through 6-54  
6-77 and 6-78  
6-81/(6-82 blank)  
7-3 through 7-10  
7-10.1 and 7-10.2  
7-11 through 7-14  
7-17/(7-18 blank)  
8-11 through 8-14  
8-27 through 8-30  
8-37 through 8-42  
8-45 and 8-46  
8-59 and 8-60  
8-67 through 8-72  
8-75 and 8-76  
9-7 through 9-17/(9-18 blank)  
11-1 and 11-2  
11-9 and 11-10  
11-10.1/(11-10.2 blank)

Remove pages	Insert pages
12-3 through 12-6	12-3 through 12-6
None	12-6.1 and 12-6.2
12-7 through 12-14	12-7 through 12-14
13-3 through 13-6	13-3 through 13-6
14-11 through 14-14	14-11 through 14-14
14-31 and 14-32	14-31 and 14-32
None	14-32.1 through 14-32.4
15-1 through 15-4	15-1 through 15-4
None	15-4.1 and 15-4.2
15-5 and 15-6	15-5 and 15-6
15-11 and 15-12	15-11 and 15-12
None	15-12.1 and 15-12.2
15-15 through 15-20	15-15 through 15-20
15-25 through 15-27/(15-28 blank)	15-25 through 15-28
17-9 through 17-14	17-9 through 17-14
17-17 and 17-18	17-17 and 17-18
17-27 through 17-29/(17-30 blank)	17-27 through 17-29/(17-30 blank)
18-5 through 18-10	18-5 through 18-10
18-15 and 18-16	18-15 and 18-16
None	18-16.1 and 18-16.2
18-17 through 18-28	18-17 through 18-25/(18-26 blank)
18-29 through 18-37/(18-38 blank)	18-29 through 18-37/(18-38 blank)
None	19-2.1 and 19-2.2
19-3 through 19-6	19-3 through 19-6
19-9 through 19-22	19-9 through 19-22
19-25 through 19-28	19-25 through 19-28
A-1 through A-4	A-1 through A-4
D-1 through D-3/(D-4 blank)	D-1 through D-4
None	E-3/(E-4 blank)
F-1 through F-6	F-1 through F-6
G-1 through G-9/(G-10 blank)	G-1 through G-9/(G-10 blank)
H-1/(H-2 blank)	H-1/(H-2 blank)
None	J-1 through J-11/(J-12 blank)
INDEX-1 through INDEX-8	INDEX-1 through INDEX-8

File this change sheet in front of the publication for reference purposes.

By Order of the Secretary of the Army:

Official:

Handwritten signature of Joel B. Hudson in black ink, written in a cursive style.

JOEL B. HUDSON

*Administrative Assistant to the  
Secretary of the Army*

DENNIS J. REIMER  
*General, United States Army  
Chief of Staff*

DISTRIBUTION:

To be distributed in accordance with the initial distribution number (IDN) 371737 requirements for TM 9-2350-311-20-2.

CHANGE

NO. 1

HEADQUARTERS  
DEPARTMENT OF THE ARMY  
WASHINGTON, D.C., 01 February 1996

UNIT MAINTENANCE MANUAL  
FOR  
CAB, ARMAMENT, SIGHTING AND FIRE CONTROL,  
ELEVATING AND TRAVERSING SYSTEMS, AND ASSOCIATED COMPONENTS  
HOWITZER, MEDIUM, SELF-PROPELLED,  
155MM

M109A2 (2350-01-031-0586) (EIC: 3EZ)

M109A3 (2350-01-031-8851) (EIC: 3E2)

M109A4 (2350-01-277-5770) (EIC: 3E8)

M109A5 (2350-01-281-1719) (EIC: 3E7)

TM 9-2350-311-20-2, 24 December 1993, is changed as follows:

1. Remove old pages and insert new pages as indicated below.
2. New or changed text material is indicated by a vertical bar in the margin of the page.

Remove pages

a through d

1-5 and 1-6

2-7 and 2-8

2-23 and 2-24

Insert pages

a through d

1-5 and 1-6

2-7 and 2-8

2-23 and 2-24

File this change sheet in front of the publication for reference purposes.

By Order of the Secretary of the Army:

DENNIS J. REIMER  
General, United States Army  
Chief of Staff

Official:

*Yvonne M. Harrison*

YVONNE M. HARRISON  
Administrative Assistant to the  
Secretary of the Army  
01186

**DISTRIBUTION:** To be distributed in accordance with DA Form 12-37-E, block 1737 requirements for TM 9-2350-311-20-2.

INSERT LATEST CHANGED PAGES.  
DESTROY SUPERSEDED PAGES

**LIST OF EFFECTIVE PAGES**

Note: The portion of the text affected by the changes is indicated by a vertical line in the outer margin of the page. Changes to illustrations are indicated by miniature pointing hands. Changes to wiring diagrams are indicated by shaded areas.

Date of issue for original and changed pages are:

Original ..... 0 ..... 24 December, 1993  
 Change ..... 1 ..... 1 February, 1996  
 Change ..... 2 ..... 31 July, 1998  
 Change ..... 3 ..... 10 January, 2000  
 Change ..... 4 ..... 31 December 2008

TOTAL NUMBER OF PAGES IN THIS PUBLICATION IS 832, CONSISTING OF THE FOLLOWING:

Page No.	*Change No.	Page No.	*Change No.	Page No.	*Change No.
Cover	4	2-16	0	3-40.1 – 3-40.2 Added	2
Pin	4	2-17	3	3-41 – 3-47	0
a	0	2-18	2	3-48 – 3-50	2
b	2	2-19 – 2-20	0	3-51 – 3-53	0
c	1	2-21 – 2-22	4	3-54 – 3-57	2
d	4	2-23	1	3-58 – 3-68	0
e - f	0	2-24 – 2-29	0	3-69	2
Change 4 Errata Added (2)	4	2-30	2	3-70	0
Change 3 Errata (2)	3	2-31	0	3-71	3
Change 2 Errata (3)	2	2-32	4	3-72 – 3-78	0
Change 1 Errata (1)	1	2-33 – 2-34	0	3-79 – 3-80	2
A	4	2-35 – 2-36	2	3-80.1 Added	2
B	4	2-37 – 2-39	0	3-80.2 Blank	2
C	4	2-40	4	3-81 – 3-82	2
D Blank	4	2-41	0	3-83 – 3-84	0
i	4	2-42 – 2-45	2	3-85	2
ii – iv	2	2-46	4	3-86 – 3-88	0
v	0	2-47 – 2-48	0	3-89-3-96	2
vi Blank	0	3-1 – 3-2	0	3-97	0
1-1 – 1-2	0	3-3 – 3-4	2	3-98	2
1-3 – 1-4	2	3-5	3	3-99 Blank	0
1-5	4	3-6 – 3-8	2	3-100 Blank	0
1-6 – 1-7	2	3-9 – 3-10	0	3-101 – 3-138	0
1-8 – 1-11	0	3-11 – 3-12	2	4-1 – 4-5	0
1-12	4	3-13-3-15	0	4-6 Blank	0
1-13 – 1-18	0	3-16	2	5-1 – 5-2	2
1-19	2	3-17 – 3-20	0	5-3 – 5-7	0
1-20 – 1-21	0	3-21	2	5-8 – 5-9	2
1-22	4	3-22	3	5-10	0
1-23 - 1-30	0	3-23-3-28	2	5-11 – 5-14	2
2-1 – 2-5	0	3-29 – 3-33	0	5-15 – 5-19	0
2-6	4	3-34	2	5-20	2
2-7	2	3-35-3-37	0	5-21 – 5-23	4
2-8	1	3-38	2	5-24 – 5-25	0
2-9 – 2-14	0	3-39	0	5-26 – 5-27	4
2-15	2	3-40	2	5-28 – 5-30	0

\*Zero in this column indicates an original page

Page No.	*Change No.	Page No.	*Change No.	Page No.	*Change No.
5-31 – 5-39	2	8-14 – 8-27	0	15-2	0
5-40	0	8-28 – 8-30	2	15-3 – 15-4	2
5-41 – 5-42	4	8-31 – 8-37	0	15-4.1 – 15-4.2 Added	2
5-42.1 Added	2	8-38	2	15-5	2
5-42.2 Blank	2	8-39	0	15-6 – 15-11	0
5-43 – 5-46	2	8-40 – 8-42	2	15-12	2
5-47 – 5-51	0	8-43 – 8-45	0	15-12.1 – 15-12.2	2
5-52	2	8-46	2	15-13 – 15-15	0
5-53 – 5-54	0	8-47 – 8-59	0	15-16	2
5-55 – 5-58	2	8-60	2	15-17	0
6-1 – 6-3	2	8-61 – 8-66	0	15-18 – 15-19	2
6-4 – 6-7	0	8-67 – 8-72	2	15-20 – 15-24	0
6-8 – 6-9	2	8-73 – 8-74	0	15-25 – 15-28	2
6-10 – 6-12	0	8-75 – 8-76	2	16-1 – 16-3	0
6-13 – 6-18	2	8-77 – 8-78	0	16-4 Blank	0
6-19	0	9-1 – 9-7	0	17-1 – 17-9	0
6-20	2	9-8 – 9-17	2	17-10 – 17-11	2
6-21 – 6-22	0	9-18 Blank	2	17-12	0
6-23 – 6-24	4	10-1 – 10-3	4	17-13 – 17-14	2
6-25 – 6-29	0	10-4 Blank	4	17-15 – 17-17	0
6-30 – 6-34	2	11-1	2	17-18	2
6-35	0	11-2 – 11-7	0	17-19 – 17-27	0
6-36	2	11-8 – 11-10	3	17-28 – 17-29	2
6-37 – 6-38	2	11-10.1 Added	2	17-30 Blank	2
6-39 – 6-43	0	11-10.2 Blank	2	18-1 – 18-5	0
6-44	2	11-11	0	18-6 – 18-10	2
6-44.1 – 6-44.6 Added	2	11-12 Blank	0	18-11 – 18-15	0
6-45 – 6-48	2	12-1 – 12-3	0	18-16	2
6-49	0	12-4	2	18-16.1 – 18-16.2 Added	2
6-50	2	12-5	3	18-17 – 18-25	2
6-51	0	12-6	2	18-26 Blank	2
6-52 – 6-54	2	12-6.1 – 12-6.2 Added	2	18-27 – 18-28 Deleted	2
6-55 – 6-77	0	12-7	2	18-29 Blank	2
6-78	2	12-8 – 12-9	0	18-30 – 18-37	2
6-79 – 6-80	0	12-10 – 12-14	2	18-38 Blank	2
6-81	2	13-1 – 13-3	0	19-1 – 19-2	0
6-82 Blank	2	13-4 – 13-5	2	19-2.1 – 19-2.2	2
7-1 – 7-2	0	13-6 – 13-8	0	19-3	2
7-3 – 7-4	4	14-1 – 14-6	0	19-4	0
7-5	3	14-7 – 14-8	3	19-5 – 19-6	2
7-6 – 7-7	2	14-9	0	19-7 – 19-9	0
7-8	4	14-10 – 14-13	3	19-10 – 19-17	2
7-9	2	14-14 – 14-16	0	19-18	0
7-10	4	14-17 – 14-20	3	19-19	2
7-10.1 – 7-10.2 Added	2	14-21 – 14-23	0	19-20 – 19-21	0
7-11	2	14-24 – 14-25	3	19-22	2
7-12	4	14-26 – 14-27	0	19-23 – 19-25	0
7-13 – 7-14	3	14-28 – 14-29	3	19-26	2
7-15	0	14-30	0	19-27	0
7-16	3	14-31 – 14-32	2	19-28	2
7-17	2	14-32.1 – 14-32.4 Added	2	19-29 – 19-33	0
7-18 Blank	2	14-33	0	19-34 Blank	0
8-1 – 8-11	0	14-34 Blank	0	A-1	
8-12 – 8-13	2	15-1	2	A-1 – A4	4

\*Zero in this column indicates an original page

Page No.	*Change No.
A-5 .....	0
A-6 Blank .....	0
B-1 .....	4
B-2 .....	0
B-13 – B-17.....	4
B-18 .....	4
B-19 .....	4
B-20 .....	0
C-1 .....	0
C-2 Blank .....	0
D-1 .....	0
D-2 .....	2
D-3 .....	4
D-4 .....	3
D-5 .....	2
D-6 Blank .....	2
E-1 – E-2.....	0
E-3 .....	2
E-4 Blank .....	2
F-1.....	0
F-2 – F-5 .....	2
F-6.....	0
G-1 .....	3
G-2 – G-4.....	2
G-5.....	3
G-6 – G-7 .....	2
G-8.....	3
G-9.....	2
G-10 Blank.....	2
H-1 .....	3
H-2 Blank .....	3
I-1.....	0
I-2 Blank.....	0
J-1 – J-11 .....	2
J-12 Blank.....	2
Index-1 .....	4
Index-2.....	0
Index-3 – Index-4.....	2
Index-5.....	0
Index-6 – Index-7.....	2
Index-8 – Index-9.....	0
Index-10 Blank.....	0
Electrical Schematic (FO-1).....	0
Electrical Schematic (FO-2).....	0
Hydraulic Schematic (FO-3) ....	0
Hydraulic Schematic (FO-4) ....	0
DA Form 2028 Sample (Part I) 4	
DA Form 2028 Sample (Part II)4	
DA Form 2028 .....	4
Metric Page.....	4
Back Cover (PIN).....	0

\*Zero in this column indicates an original page

**Change 4**

**C/(D blank)**





TECHNICAL MANUAL }  
 No. 9-2350-311-20-2 }

HEADQUARTERS  
 DEPARTMENT OF THE ARMY  
 WASHINGTON, D.C., 24 December 1993

**UNIT MAINTENANCE MANUAL  
 FOR  
 CAB, ARMAMENT, SIGHTING AND FIRE CONTROL,  
 ELEVATING AND TRAVERSING SYSTEMS, AND ASSOCIATED COMPONENTS  
 HOWITZER, MEDIUM, SELF-PROPELLED  
 155MM**

**M109A2 (2350-01-031-0586) (EIC: 3EZ)  
 M109A3 (2350-01-031-8851) (EIC: 3E2)  
 M109A4 (2350-01-277-5770) (EIC: 3E8)  
 M109A5 (2350-01-281-1719) (EIC: 3E7)**

<b>REPORTING ERRORS AND RECOMMENDING IMPROVEMENTS</b>
<p>You can help improve this publication. If you find any mistakes or if you know of a way to improve the procedures, please let us know. Submit your DA Form 2028 (Recommended Changes to Equipment Technical Publications), through the Internet, on the Army Electronic Product Support (AEPS) website. The Internet address is <a href="https://aeeps.ria.army.mil">https://aeeps.ria.army.mil</a>. The DA Form 2028 is located under the Public Applications section in the AEPS Public Home Page. Fill out the form and click on SUBMIT. Using this form on the AEPS will enable us to respond quicker to your comments and better manage the DA Form 2028 program. You may also mail, fax or E-mail your letter or DA Form 2028 direct to: TACOM Life Cycle Management Command ATTN: AMSTA-LC-LMPP/TECH PUBS, 1 Rock Island Arsenal, Rock Island, IL 61299-7630. The email address is ROCK-TACOM-TECH-PUBS@conus.army.mil. The fax number is DSN 793-0726 or Commercial (309) 782-0726.</p>
DISTRIBUTION STATEMENT A. Approved for public release; distribution is unlimited.

**TABLE OF CONTENTS**

	<u>Page</u>
<b>HOW TO USE THIS MANUAL</b> .....	<b>iv</b>
<b>CHAPTER 1 INTRODUCTION</b> .....	<b>1-1</b>
Section I. General Information .....	1-3
Section II. Equipment Description and Data .....	1-8
Section III. Principles of Operation .....	1-23
<b>CHAPTER 2 GENERAL CAB MAINTENANCE</b> .....	<b>2-1</b>
Section I. Repair Parts, Tools, Special Tools, Test, Measurement, and Diagnostic Equipment (TMDE), and Support Equipment .....	2-2
Section II. Service Upon Receipt .....	2-3
Section III. Preventive Maintenance Checks and Services (PMCS) and Lubrication Instructions and Mandatory Replacement Parts .....	2-18
Section IV. General Maintenance Procedures .....	2-33
Section V. Preparation for Storage or Shipment .....	2-40

\*This manual supersedes the following manual: TM 9-2350-311-20-2, June 1986, and all changes.

TABLE OF CONTENTS - CONTINUED

	<u>Page</u>
CHAPTER 3 <b>TROUBLESHOOTING</b> .....	3-1
CHAPTER 4 BEARING PROTECTIVE SHIELDS AND BEARING RACE RING ASSEMBLY .....	4-1
CHAPTER 5 MOUNT AND HOWITZER ASSEMBLY .....	5-1
CHAPTER 6 <b>CAB HYDRAULICS</b> .....	6-1
CHAPTER 7 <b>RAMMER SYSTEM</b> .....	7-1
CHAPTER 8 <b>CAB ELECTRICAL SYSTEM</b> .....	8-1
Section I. Electrical Leads And Harnesses .....	8-2
Section II. Component Maintenance .....	8-47
Section III. Intercommunications System .....	8-67
CHAPTER 9 <b>CAB ELECTRICAL CONTACT BOARD AND CONTACT ARM ASSEMBLIES</b> .....	9-1
CHAPTER 10 <b>CAB WEATHER COVER</b> .....	10-1
CHAPTER 11 <b>TURRET LOCK AND TRAVERSING MECHANISM ASSEMBLIES</b> .....	11-1
CHAPTER 12 <b>COMMANDER'S CUPOLA</b> .....	12-1
CHAPTER 13 <b>COMMANDER'S SEAT ASSEMBLY</b> .....	13-1
CHAPTER 14 <b>DOOR AND HATCH ASSEMBLIES</b> .....	14-1
■ CHAPTER 15 <b>CAB STOWAGE AND HANDLES</b> .....	15-1
Section I. Cab Ammo Rack .....	15-3
Section II. Stowage Boxes .....	15-6
Section III. Stowage Brackets .....	15-13
Section IV. Stowage Racks .....	15-24
■ Section V. Handles .....	15-28
CHAPTER 16 <b>PANORAMIC TELESCOPE BALLISTIC COVER</b> .....	16-1
CHAPTER 17 <b>NUCLEAR, BIOLOGICAL, AND CHEMICAL (NBC) PROTECTION EQUIPMENT</b> .....	17-1
CHAPTER 18 <b>FIRE CONTROL</b> .....	18-1
CHAPTER 19 <b>PURGING AND CHARGING</b> .....	19-1
APPENDIX A REFERENCES .....	A-1

**TABLE OF CONTENTS – CONTINUED**

	<u>Page</u>
<b>APPENDIX B</b> <b>MAINTENANCE ALLOCATION CHART (MAC)</b> .....	<b>B-1</b>
Section I. Introduction .....	B-1
Section II. Maintenance Allocation Chart – Cab Armament, Sighting and Fire Control, Elevating and Traversing Systems and Associated Parts .....	B-4
Section III. Tools and Test Equipment .....	B-17
Section IV. Remarks .....	B-19
<b>APPENDIX C</b> <b>REPAIR PARTS AND SPECIAL TOOLS LIST</b> .....	<b>C-1</b>
<b>APPENDIX D</b> <b>EXPENDABLE AND DURABLE ITEMS LIST</b> .....	<b>D-1</b>
Section I. Introduction .....	D-1
Section II. Expendable and Durable Items List .....	D-1
<b>APPENDIX E</b> <b>ILLUSTRATED LIST OF MANUFACTURED ITEMS</b> .....	<b>E-1</b>
<b>APPENDIX F</b> <b>TORQUE LIMITS</b> .....	<b>F-1</b>
<b>APPENDIX G</b> <b>MANDATORY REPLACEMENT PARTS LIST</b> .....	<b>G-1</b>
<b>APPENDIX H</b> <b>TOOL IDENTIFICATION LIST</b> .....	<b>H-1</b>
<b>APPENDIX I</b> <b>SCHEMATIC SYMBOLS</b> .....	<b>I-1</b>
<b>APPENDIX J</b> <b>RECOIL EXERCISER INSTRUCTION</b> .....	<b>J-1</b>

## HOW TO USE THIS MANUAL

### This manual consists of:

1. Instructions for unit maintenance on the M109A2/M109A3/M109A4/M109A5, 155MM, Self-Propelled, Medium, Howitzer cab systems and components.
2. Location, description, and basic operation characteristics of the M109A2/M109A3/M109A4/M109A5 howitzer cab systems and components.
3. Cab systems/components maintenance procedures to:
  - a. Prepare the M109A2/M109A3/M109A4/M109A5 howitzer for service upon receipt.
  - b. Perform operational checks for systems/components.
  - c. Perform preventive maintenance on systems/components.
  - d. Perform troubleshooting of malfunctioning systems/components (isolation of malfunction causes).
  - e. Remove, repair, and install cab system/components.

4. Appendixes for detailed listings of:

Appendix A. References applicable to M109A2/M109A3/M109A4/M109A5 howitzer, including supply manuals, forms, and other M109A2/M109A3/M109A4/M109A5 publications.

Appendix B. Maintenance policy, definition of terms. Maintenance Allocation Chart (MAC).

Appendix C. Reference to applicable Repair Parts and Special Tools List (RPSTL).

Appendix D. Expendable and durable items list.

Appendix E. Illustrated list of manufactured items.

Appendix F. Torque limits.

Appendix G. Mandatory replacement parts list.

Appendix H. Tool identification list.

Appendix I. Schematic Symbols.

Appendix J. Recoil Exerciser Instruction

Index

Foldouts (FOs): Electrical and hydraulic schematics.

## HOW TO USE THIS MANUAL – CONTINUED

### Indexing

Five major indexing procedures are used in this manual to help mechanics locate information rapidly.

1. Cover Index: Lists sections of text and page number. Includes index mark which lines up with index marks on the actual page of reference.

Example: Troubleshooting 3–1

2. Table of Contents.
3. Chapter and section indexes listing data/information covered within the chapter and section.
4. Quick Guide to Troubleshooting identifies system malfunction and provides paragraph references for specific troubleshooting procedures or maintenance action.
5. Index: Alphabetical listing of information.

### Maintenance Text and Illustrations (Chapters 4 through 19)

1. Maintenance procedures are to be performed in the sequence shown in the text and illustrations. Step 1 must be performed before Step 2. Procedure A must be performed before Procedure B, and so on.
2. Equipment illustrations use numbers to identify parts of the system/components.

Example: Remove two cap screws (7) and two lockwashers (8).

3. This manual is written to include all parts authorized to be used or repaired at the unit level using Repair Parts and Special Tools List (RPSTL) (TM 9–2350–311–24P–2) as a guide. All parts with SMR code maintenance levels “O” are mentioned in the order of functional group codes whenever possible, to enable location in the RPSTL.



# CHAPTER 1

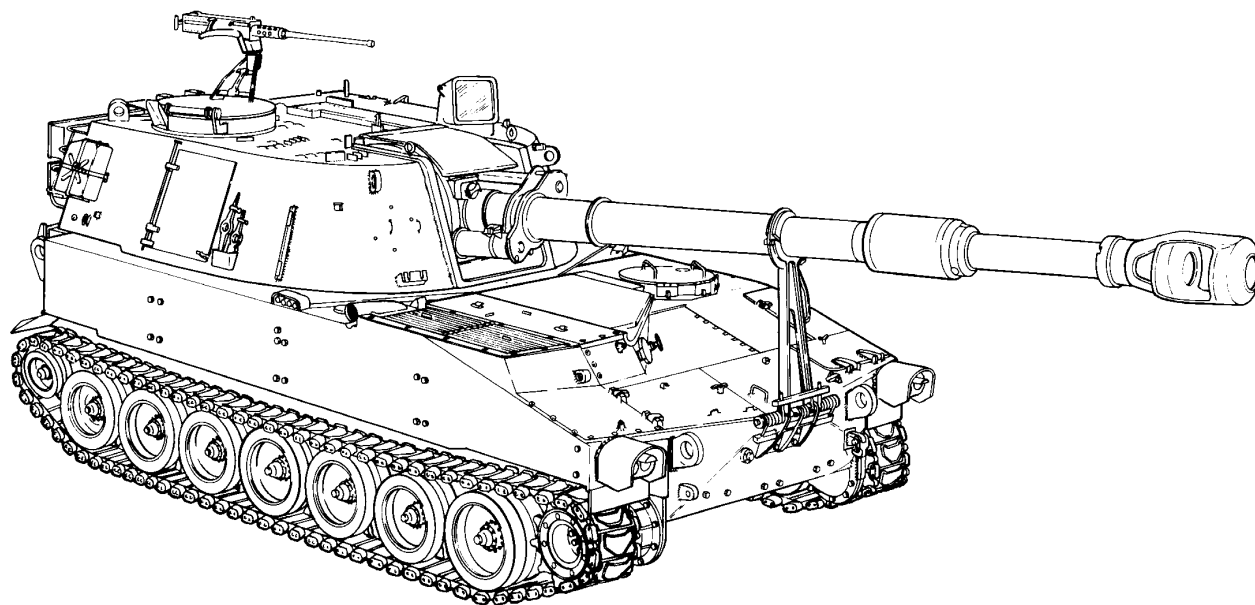
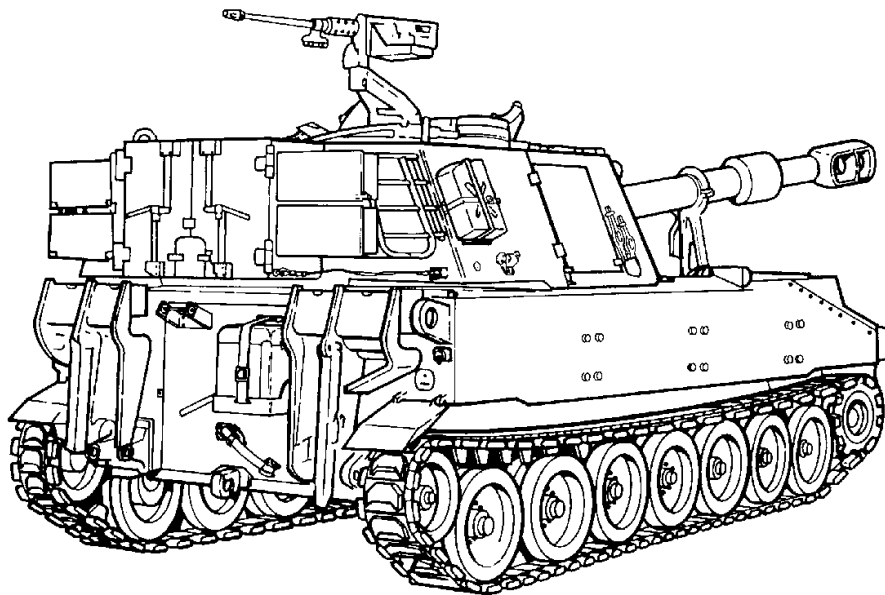
## INTRODUCTION

### GENERAL

This chapter provides a general introduction to the purposes, safe use, and capabilities of the howitzer. Section I describes procedures for destroying equipment to prevent enemy use, references to other technical manuals, and forms to recommend improvements. Sections II and III familiarize the mechanic with equipment data and operating principles of the howitzer's systems.

<u>CONTENTS</u>	<u>Page</u>
Section I. GENERAL INFORMATION	
1-1 SCOPE .....	1-3
1-2 MAINTENANCE FORMS, RECORDS, AND REPORTS .....	1-3
1-3 DESTRUCTION OF ARMY MATERIEL TO PREVENT ENEMY USE .....	1-3
1-4 PREPARATION FOR STORAGE OR SHIPMENT .....	1-4
1-5 QUALITY ASSURANCE (QA) .....	1-4
1-6 OFFICIAL NOMENCLATURE, NAMES, AND DESIGNATIONS .....	1-4
1-7 REPORTING EQUIPMENT IMPROVEMENT RECOMMENDATIONS (EIR) .....	1-6
1-8 WARRANTY INFORMATION .....	1-6
1-9 SAFETY, CARE, AND HANDLING .....	1-6
1-10 CORROSION PREVENTION AND CONTROL (CPC) .....	1-7
1-11 NUCLEAR HARDNESS .....	1-7
1-12 SECURITY MEASURES FOR ELECTRONIC DATA .....	1-7
Section II. EQUIPMENT DESCRIPTION AND DATA	
1-13 EQUIPMENT CHARACTERISTICS, CAPABILITIES, AND FEATURES .....	1-8
1-14 LOCATION AND DESCRIPTION OF MAJOR COMPONENTS .....	1-8
1-15 DIFFERENCES BETWEEN MODELS .....	1-17
1-16 EQUIPMENT DATA .....	1-20
1-17 EQUIPMENT CONFIGURATION .....	1-23
Section III. PRINCIPLES OF OPERATION	
1-18 EQUIPMENT OPERATION AND DESCRIPTION .....	1-23





M109A2/M109A3/M109A4/M109A5

---

## Section I. GENERAL INFORMATION

---

### 1–1 SCOPE

---

- a. Type of Manual: Unit maintenance.
  - b. Model Number and Equipment Name: M109A2/M109A3/M109A4/M109A5 Howitzer, Medium, Self-Propelled, 155MM. This manual deals with maintenance for the cab and associated components. TM 9–2350–311–20–1 deals with maintenance of the hull and associated components.
  - c. Purpose of Equipment: The howitzer cab, containing the M185 or M284 155MM cannon and secondary armament M2 heavy barrel caliber 50 machine gun, provides the firepower for the howitzer. The cab components also provide the fire control for the 155MM cannon.
- 

### 1–2 MAINTENANCE FORMS, RECORDS, AND REPORTS

---

- a. Department of the Army forms and procedures used for equipment maintenance will be those prescribed by (as applicable) DA PAM 738–750, The Army Maintenance Management System; DA PAM 738–751, Functional Users Manual for the Army Maintenance Management System–Aviation (TAMMS–A); or AR 700–138, Army Logistics Readiness and Sustainability.
  - b. Accidents involving injury to personnel or damage to materiel will be reported on DA Form 285 (Accident Report) in accordance with AR 385–40. Explosives and ammunition malfunctions will be reported in accordance with AR 75–1.
- 

### 1–3 DESTRUCTION OF ARMY MATERIEL TO PREVENT ENEMY USE

---

Refer to TM 750–244–6 for procedures on how to destroy the M109 self-propelled howitzer. You will find procedures for destruction of munitions in TM 43–0002–33 (improved conventional munitions). Procedures for destruction of chemical munitions are outlined in TM 3–250.

Below are some general guidelines to follow in destruction of equipment to prevent enemy use.

Destruction of the vehicle, armament, and equipment when subject to capture or abandonment in a combat zone, will be undertaken only when the unit commander decides such action is necessary in accordance with orders of, or policy established by, the Army commander.

In general, destruction of essential parts, followed by burning, will usually be sufficient to render the vehicle, armament, and equipment useless. Time is usually critical.

Materiel must be damaged so that it cannot be restored to usable condition by either repair or cannibalization. If a lack of time or personnel prevents destruction of all parts, give priority to destruction of parts hardest to replace. It is important that the same parts be destroyed on all units to prevent construction of one complete unit from several damaged ones.

All items of sighting and fire control instruments and equipment, especially telescopes, gunner's quadrants, and binoculars, are costly and difficult to replace. They should be conserved whenever possible. If you cannot carry them with you, destroy them by smashing with your sledgehammer, pick, or mattock. Throw the pieces in all directions.

### **1-3 DESTRUCTION OF ARMY MATERIEL TO PREVENT ENEMY USE — CONTINUED**

---

When time is short, a method of destroying the equipment with materiel at hand is as follows:

Retrieve or smash sighting and fire control equipment.

Load cannon with projectile and full powder charge. Attach a 50 foot (15.2 m) or longer lanyard to firing mechanism. Disconnect recoil cylinder lines and fire the weapon.

Take a sledgehammer and bend the end of the counter recoil buffer rod.

A second method is to close the breechblock and toss several thermite grenades down the cannon tube. Elevate the cannon tube so that the grenades will fall against the breechblock. This will melt the breech and the powder chamber, causing them to fuse together.

---

### **1-4 PREPARATION FOR STORAGE OR SHIPMENT**

---

Instructions on proper storage and shipment of the M109 self-propelled howitzer series are covered in Chapter 2, General Cab Maintenance, of this manual.

---

### **1-5 QUALITY ASSURANCE (QA)**

---

No particular quality assurance manual pertains specifically to the M109 howitzer series.

Defective material received through the supply system should be reported on Product Quality Deficiency Report (QDR) SF 368. Instructions for preparing QDRs are provided in AR 702-7, Reporting of Quality Deficiency Data. QDRs should be mailed directly to:

Commander  
U.S. Army Armament Research, Development and Engineering Center  
ATTN: AMSTA-AR-QAW-A (R)/Customer Feedback Center  
Rock Island, IL 61299-7300

We will send you a reply.

---

### **1-6 OFFICIAL NOMENCLATURE, NAMES, AND DESIGNATIONS**

---

Nomenclature in this manual was chosen in accordance with the terms used for provisioning as they appear in the Repair Parts and Special Tools List (TM 9-2350-311-24P-2) and Maintenance Allocation Chart, Appendix B. A few tools and cab components however are referred to by names more common than those in the RPSTL. In many cases the more common name is a shorter name for the same component.

## Nomenclature Cross-Reference

Manual Nomenclature

Adjuster  
Assistant gunner's control assembly  
Cab ammo rack  
Cannon tube  
Cap screw  
Connector  
Equilibrated elevating cylinder  
Gunner's control assembly  
Hex key  
Howitzer  
LED  
Lockwire  
M1A1/M1A2 collimator  
M178 mount  
M182 mount  
Radar antenna bracket  
Slip ring segment board  
Soap  
Turret lock  
Hygroscopic

Official Nomenclature

Helical compressor seat  
Control assembly, right gunner's  
Cab ammunition rack  
Tube assembly  
Hexagon head cap screw  
Electrical plug connector  
Cannon equilibrator  
Control assembly, left gunner's  
Socket head screw key  
155MM medium self-propelled howitzer,  
M109A2/M109A3/M109A4/M109A5  
Light emitting diode  
Safety wire/nonelectrical wire  
Infinity aiming reference collimator M1A1/M1A2 ■  
Howitzer M178 mount  
Howitzer M182 mount  
Radar mast base  
Electrical contact race ring (or race ring segment)  
Cleaning compound  
Cab traverse lock  
Reservoir filter dryer ■

---

## 1-7 REPORTING EQUIPMENT IMPROVEMENT RECOMMENDATIONS (EIR)

---

If your howitzer needs improvement, let us know. Send us an EIR. You, the user, are the only one who can tell us what you don't like about your equipment. Let us know why you don't like the design or performance. Put it on a SF 368 (Product Quality Deficiency Report). Mail it to: Commander, U.S. Army Armament Research, Development and Engineering Center, ATTN: AMSTA-AR-QAW-A (R)/Customer Feedback Center, Rock Island, IL 61299-7300.

---

## 1-8 WARRANTY INFORMATION

---

The M109 howitzer series is no longer warranted.

---

## 1-9 SAFETY, CARE, AND HANDLING

---

**WARNING**

Nuclear, Biological, and Chemical (NBC) agents can kill you. If NBC exposure is suspected, all air filter media must be handled by personnel wearing full NBC protective equipment (FM 3-4).

**WARNING**



The M1A1 collimator is radioactively illuminated. Check for presence of illumination and damage. If discovered broken, damaged, or defective, follow the procedures on page b.



The M140 alignment device is radioactively illuminated. Check for loss of luminescence, breakage, damage, or defects. If present, follow the procedures on page b.

- a. Deleted.
- b. Prior to purging or charging, make the following checks:
  - 1 Lift cover assembly and check for cracks or loss of illumination.
  - 2 Look through objective end of collimator and check for broken/cracked reticle and loss of illumination. If reticle is intact, no cracks are observed, and collimator is illuminated, proceed with maintenance actions.
  - 3 If cracks are observed, but collimator is still illuminated, remove collimator scope and notify the local Radiation Protection Officer (RPO). Seal collimator scope in a double plastic bag (item 5, Appx D) and return it to depot for disposal.

- 4 If no illumination is observed, remove collimator scope and check for illumination in a dark room. If a slight glow/haze appears, follow procedure in step 3. If illumination still is not detected, notify local RPO. Return collimator scope to depot as follows for disposal.
  - (a) Seal collimator scope in double plastic bag (item 5, Appx D) and place in strong, tight container (such as fiberboard box (item 6, Appx D)) with all seams secured using tape (item 38, Appx D) (masking tape is not authorized).
  - (b) Label the container: CAUTION – BROKEN H<sub>3</sub> SOURCE. DO NOT OPEN.

## 1-10 CORROSION PREVENTION AND CONTROL (CPC)

Corrosion Prevention and Control (CPC) of Army materiel is a continuing concern. It is important that any corrosion problems with the howitzer be reported so that the problem can be corrected and improvements can be made to prevent the problem in the future.

While corrosion is typically associated with rusting of metals, it can also include deterioration of other materials, such as rubber and plastic. Unusual cracking, softening, swelling, or breaking of these materials may be a corrosion problem.

If a corrosion problem is identified, it can be reported using SF 368, Product Quality Deficiency Report. Use of keywords such as “corrosion,” “rust,” “deterioration,” or “cracking” will ensure that the information is identified as a CPC problem.

The form should be submitted to:

Commander  
 U.S. Army Armament Research, Development and Engineering Center  
 ATTN: AMSTA-AR-QAW-A (R)/Customer Feedback Center  
 Rock Island, IL 61299-7300

## 1-11 NUCLEAR HARDNESS

Not applicable.

## 1-12 SECURITY MEASURES FOR ELECTRONIC DATA

Not applicable.

## Section II. EQUIPMENT DESCRIPTION AND DATA

---

### 1-13 EQUIPMENT CHARACTERISTICS, CAPABILITIES, AND FEATURES

---

The self-propelled medium howitzer is air transportable. The cab receives electrical power from the batteries and transmits this electrical power to components throughout the 6400 mils traverse by means of 3 or 5 contact arm assemblies. The cab power pack and accumulator provide cab hydraulic power. The NBC system (on M109A4/M109A5 howitzers) provides protection to crew members in a nuclear, biological, or chemical environment.

The cab supplies elevation and azimuth control for the 155mm cannon assembly. Refer to TM 9-2350-311-10 for operator's instructions.

An electrically driven hydraulic pump supplies power for the elevation and depression of the cannon assembly, for operation of the projectile rammer and for traversing the cab. The elevation and cab traversing systems also have manual backup capabilities.

The primary armament for the howitzer is a 155MM cannon assembly. The secondary armament is a caliber 50 machine gun.

---

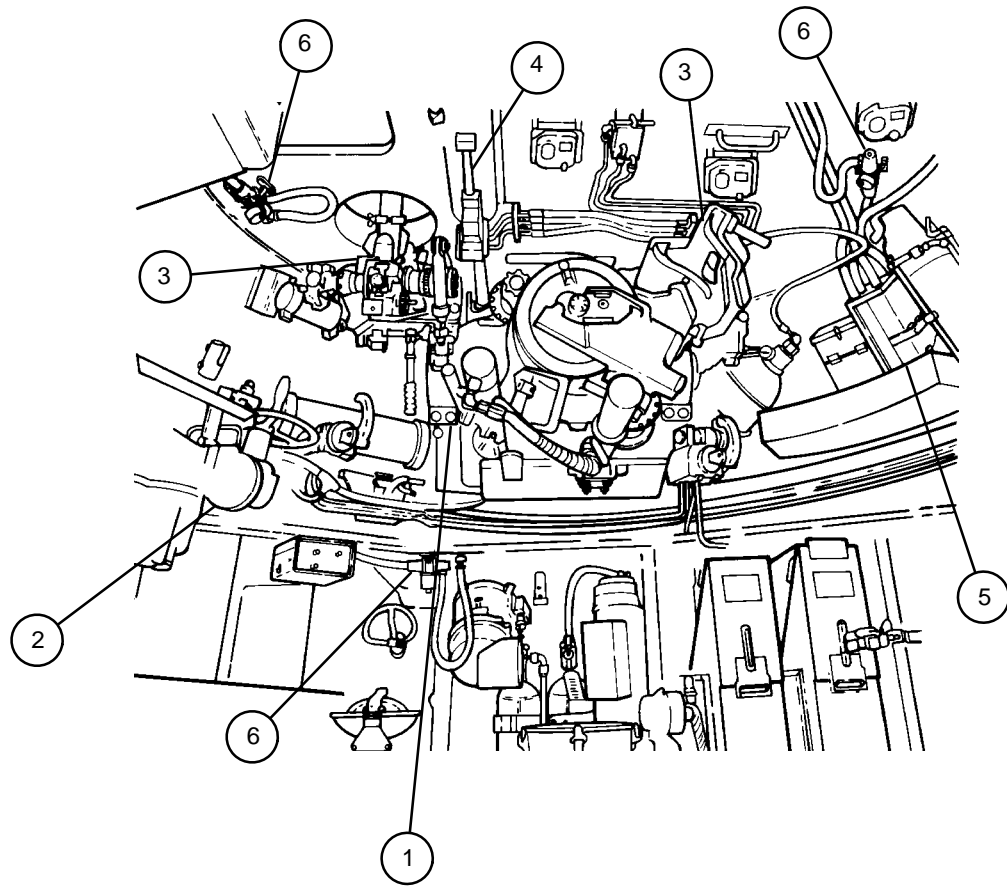
### 1-14 LOCATION AND DESCRIPTION OF MAJOR COMPONENTS

---

Refer to para 1-14.1 for location of major components inside the howitzer cab. Refer to para 1-14.2 for location of major components on the outside of the cab.

#### 1-14.1 Location and Description of Major Internal Components

- a. Rammer Assembly. The rammer assembly (1) is weapon mounted and hydraulically powered, with positive ram. Its two positions are stow and ram.
- b. Traversing Mechanism. The traversing mechanism (2) is hydraulically operated but has a manual backup in case of system failure. The M109A2/M109A3 howitzers have automatic electric clutches, while the M109A4/M109A5 howitzers have hydraulic clutches. The traversing mechanism allows the cab to traverse at 6400 mils.
- c. Sighting Equipment-Optical Sighting Equipment. The sighting equipment (3) can be adjusted for cant and provides capability for direct or indirect fire (direct not shown).
- d. Equilibrated Elevating Cylinder. The equilibrated elevating cylinder (4) provides elevation and depression for cannon assembly.
- e. NBC System (M109A4/M109A5 Howitzers). M2A2 air purifier (5) provides filtered air to the M3 electrical air heaters (6). Each station has its own M3 electrical air heater to control temperature for personal comfort. Hoses connect M2A2 air purifier to M25A1 masks.



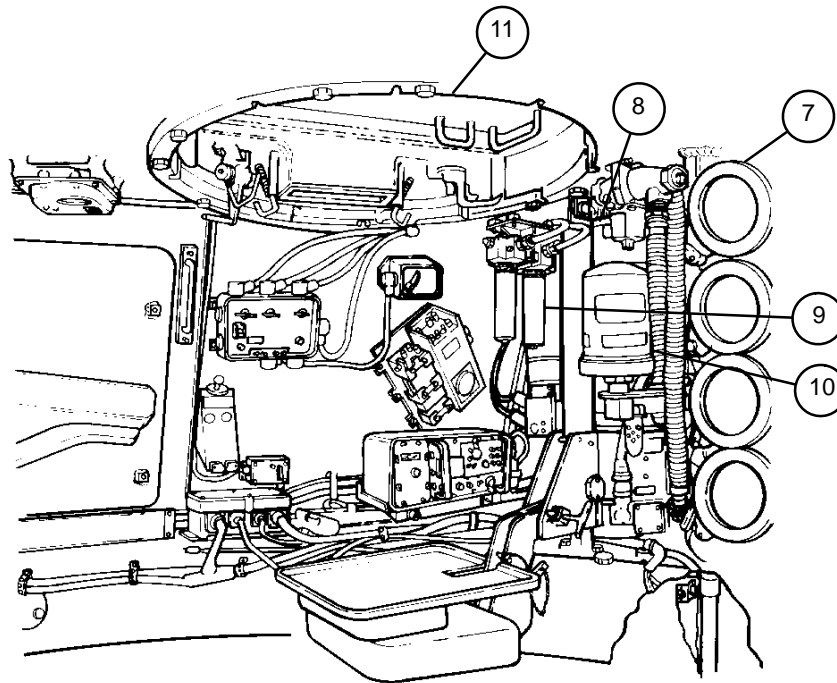
FRONT LEFT VIEW  
CAB INTERIOR



## 1-14 LOCATION AND DESCRIPTION OF MAJOR COMPONENTS — CONTINUED

### 1-14.1 Location and Description of Major Internal Components — Continued

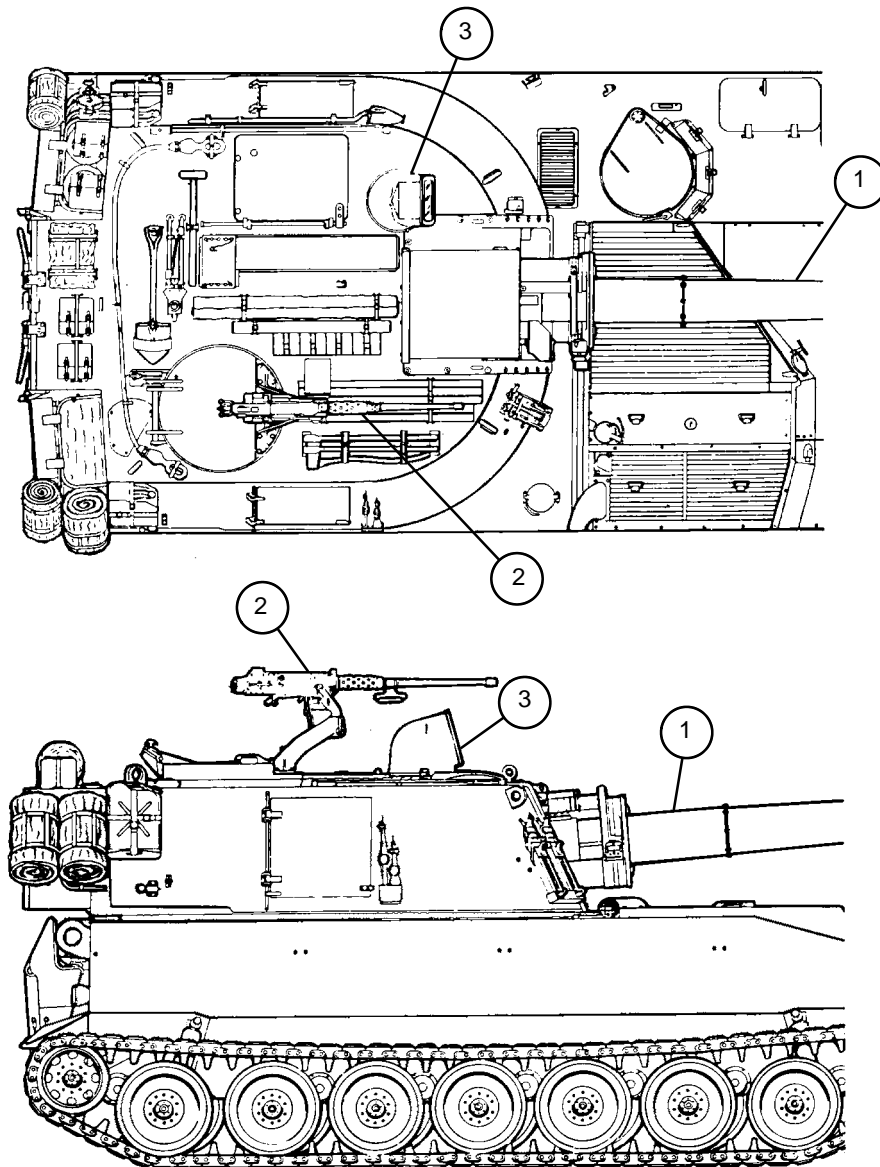
- f. Cab Ammo Rack. The cab ammo rack (7) allows easy access to 22 rounds of 155mm projectiles. Quick-release retainer assemblies hold projectiles.
- g. Power Pack Assembly. The power pack assembly (8) features an electrically driven hydraulic pump, a hydraulic fluid reservoir, and a sight gage assembly for easy hydraulic fluid level checks. The M109A2/M109A3 howitzers filter fluid using a strainer and filter. The M109A4/M109A5 howitzers hydraulically filter fluid using two external filters (9) and filter air and water from the hydraulic system using air line filter and hydroscopic breather (10).
- h. Commander's Cupola. The commander's cupola (11) serves as mount and support for M2 machine gun, holds M27 periscope, and traverses 6400 mils.



RIGHT REAR  
CAB INTERIOR

**1-14.2 Location and Description of Major External Components**

- a. Mount And Howitzer Assembly. The mount and howitzer assembly (1) contains a 155MM cannon assembly, a gas operated bore evacuator (not shown), a muzzle brake (not shown), an interrupted screw breechblock, and a counter recoil activated breech mechanism with provision for manual operation, and has a variable recoil capability (long recoil-low angle, short recoil-high angle). It is central bore mounted and fired mechanically by lanyard.
- b. Caliber 50 Machine Gun, M2. The automatic, recoil operated, link belt fed, heavy barrel M2 caliber 50 machine gun (2) has a flexible type configuration and is fired manually.
- c. Panoramic Telescope Ballistic Cover. The panoramic telescope ballistic cover (3) provides clear field of view for M117/M117A2 panoramic telescope and traverses 6400 mils.



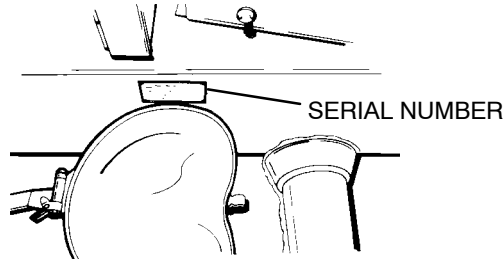
---

## 1-14 LOCATION AND DESCRIPTION OF MAJOR COMPONENTS — CONTINUED

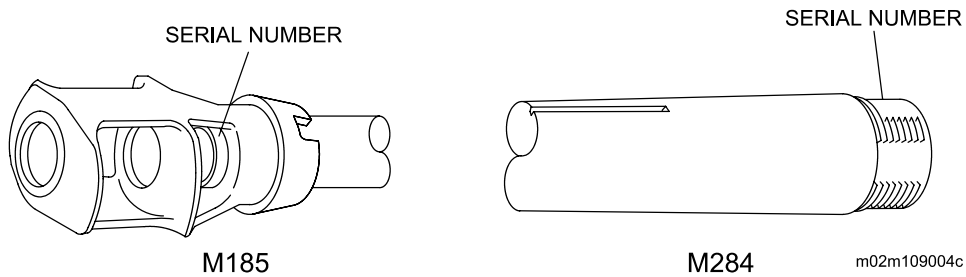
---

### 1-14.3 Serial Number Locations

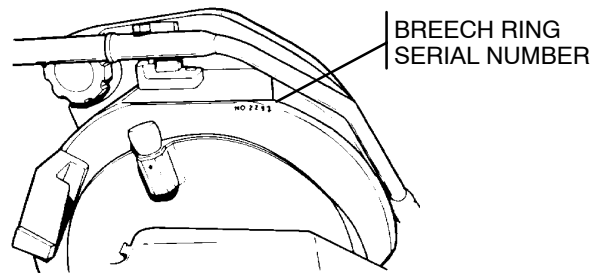
- a. Vehicle serial number is on vehicle data plate, left of driver's seat.



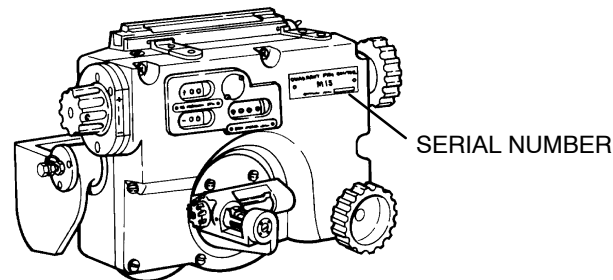
- b. M185 Cannon tube serial number is located on tip of cannon tube. M284 tube serial number is on rear of tube.



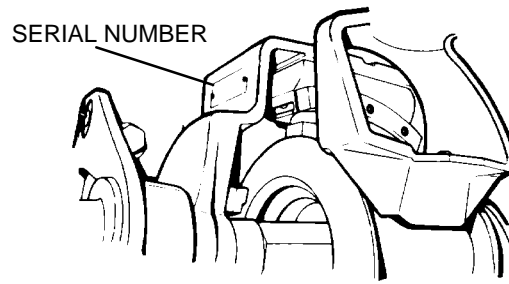
- c. Breech serial number is on rear of breech ring.



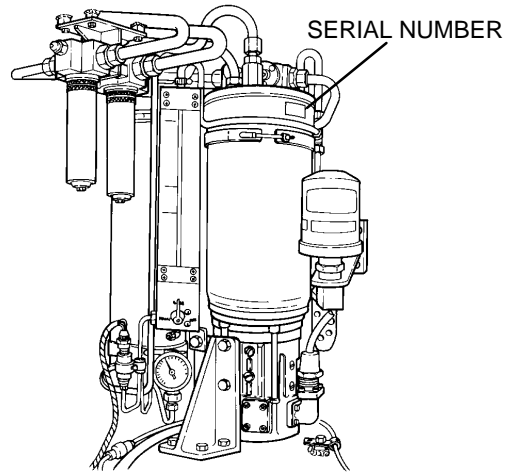
- d. M15 elevation quadrant serial number is located in upper right hand corner.



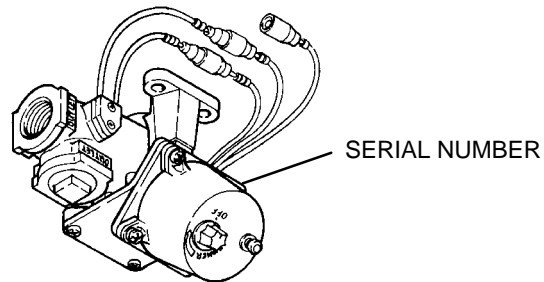
- e. M145/M145A1 telescope mount serial number is on upper left side.



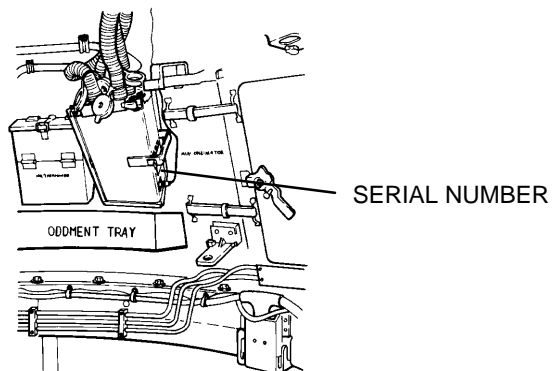
- f. Power pack assembly serial number is on upper front side on nameplate.



- g. M3 electrical air heater serial number is on control unit.



- h. M2A2 air purifier serial number is on lower side by electrical connector.



**1-14 LOCATION AND DESCRIPTION OF MAJOR COMPONENTS — CONTINUED**

**1-14.4 Data Plates**

There are equipment data plates provided, pertaining to the separate howitzer models. Each plate provides a space to enter the vehicle serial number.

**NOTE**

These data plates are to be changed at a later date to correct TM information – Date TBD.

HOWITZER, MEDIUM, SELF-PROPELLED:155MM,M109A2  
 CREW 6 MEN  
 U.S. ARMY SERIAL NO.   
 M'FD BY:  
 OPERATOR'S MANUAL: TM9-2350-303-10  
 MAINT. MANUALS: LO9-2350-303-12, TM9-2350-303-  
 -20-1, 20-2-20P-1, -20P-2, 34-1, -34-2, 34P-1, 34P-2  
 MAX. VEHICLE SPEEDS  
 LOW: 6 MPH HIGH: 35 MPH REVERSE: 7 MPH  
 OVERALL LENGTH: 359 LOWEST OPERABLE HEIGHT: 114  
 OVERALL WIDTH: 124 SHIPPING VOLUME: 2573 FT<sup>3</sup>  
 OVERALL HEIGHT: 129 FIGHTING WEIGHT: 27.5 TONS  
 NATIONAL STOCK NO.: 2350-01-031-0586

HOWITZER, MEDIUM, SELF-PROPELLED  
 155MM, M109A4  
 CREW: 6 MEN VEHICLE SERIAL NO.   
 MODIFIED BY:  
 OPERATOR'S MANUAL: TM 9-2350-311-10  
 MAINT MANUALS: LO9-2350-311-12, TM9-2350-311-20-1,  
 -20-2, -20P-2, -24P-1, -34-1, -34-2, -34P-2  
 MAX VEHICLE SPEEDS  
 LOW: 6 MPH HIGH: 35 MPH REVERSE: 7 MPH  
 OVERALL LENGTH: 359 LOWEST OPERABLE HEIGHT: 114  
 OVERALL WIDTH: 124 SHIPPING VOLUME: 2573 CU FT  
 OVERALL HEIGHT: 129 FIGHTING WEIGHT: 27.5 TONS  
 NATIONAL STOCK NO.:  
 VEHICLE MODIFIED

HOWITZER, MEDIUM, SELF-PROPELLED 155MM, M109A3  
 CREW: 6 MEN  
 U.S. ARMY SERIAL NO.   
 M'FD BY:  
 OPERATOR'S MANUAL: TM9-2350-217-10N  
 MAINT. MANUALS: LO9-2350-217-12N, TM9-2350-217-20N  
 MAX. VEHICLE SPEEDS  
 LOW: 6 MPH HIGH: 35 MPH REVERSE: 7 MPH  
 OVERALL LENGTH: 359 LOWEST OPERABLE HEIGHT: 114  
 OVERALL WIDTH: 124 SHIPPING VOLUME: 2573 FT<sup>3</sup>  
 OVERALL HEIGHT: 129 FIGHTING WEIGHT: 27.5 TONS  
 NATIONAL STOCK NO.: 2350-01-031-8851

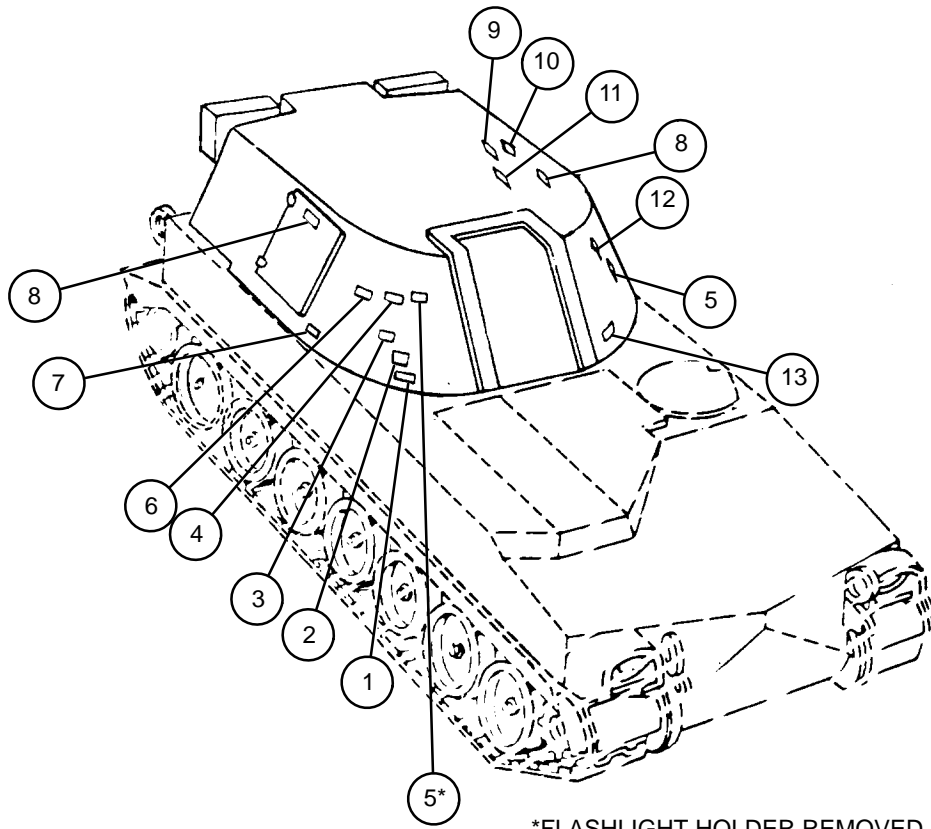
HOWITZER, MEDIUM, SELF-PROPELLED: 155MM, M109A5  
 CREW 6 MEN  
 US ARMY SERIAL NO.   
 M'FD BY :   
 OPERATOR'S MANUAL: TM 9-2350-311-10  
 MAINT MANUALS: LO 9-2350-311-12, TM 9-2350-311-20-1,  
 -20-2, -20P-2, -24P-1, -34-1, -34-2, -34P-2  
 MAX VEHICLE SPEEDS  
 LOW: 6MPH HIGH: 35 MPH REVERSE: 7 MPH  
 OVERALL LENGTH: 361 LOWEST OPERABLE HEIGHT: 114  
 OVERALL WIDTH: 124 SHIPPING VOLUME: 2573 FT3  
 OVERALL HEIGHT: 129 FIGHTING WEIGHT: 27.5 TONS  
 NATIONAL STOCK NO.:

**1-14.5 Stencils**

a. Apply stencils or restencil to ensure legibility as follows:

- 1 Before applying stencils, clean and prime metal.
- 2 Letters must be black.
- 3 Letters must be 1/10 inch (2.5 mm) x 1/2 inch (12.7 mm) high.
- 4 Spacing between lines must be 1/4 inch (6.4 mm).

b. Interior Stencil Locations



\*FLASHLIGHT HOLDER REMOVED  
ON M109A4/M109A5 HOWITZERS

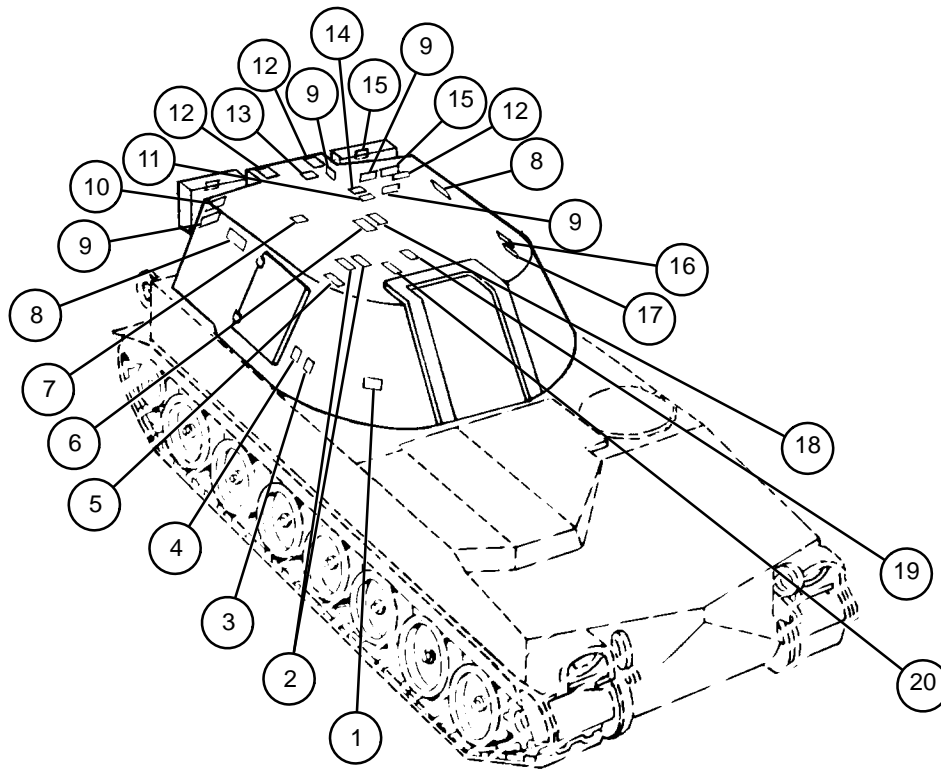
LEGEND:

- |                    |                       |
|--------------------|-----------------------|
| 1. Accumulator     | 8. Stowage            |
| 2. Oddments        | 9. M16 Fuze Wrench    |
| 3. Rations         | 10. M13A2 Powder Cans |
| 4. Canteen         | 11. M18 Fuze Wrench   |
| 5. Flashlights     | 12. Flares            |
| 6. M27 periscope   | 13. Cab Traverse Lock |
| 7. M1A1 collimator |                       |

1-14 LOCATION AND DESCRIPTION OF MAJOR COMPONENTS — CONTINUED

1-14.5 Stencils — Continued

c. Exterior Stencil Locations



LEGEND:

- |                   |                  |
|-------------------|------------------|
| 1. Track Fixture  | 11. Sledge       |
| 2. Handles        | 12. Field Packs  |
| 3. Mattock        | 13. Tow Cable    |
| 4. Pick           | 14. Tripod       |
| 5. Axe            | 15. Stowage      |
| 6. Cal .50 Barrel | 16. Crowbar      |
| 7. Shovel         | 17. Shovel       |
| 8. Water Cans     | 18. Aiming Post  |
| 9. Bed Rolls      | 19. .50 Cal Ammo |
| 10. Paulin        | 20. Staff        |

---

## 1-15 DIFFERENCES BETWEEN MODELS

---

Most of the differences among components of M109A2 and M109A3 howitzers concern the M109A3 model. There are 103 differences in the cabs of the M109A3 vehicle population. Variations among M109A2 vehicles and differences between M109A2 and M109A3 vehicles are minimal.

M109A4 howitzers have updated hydraulic and electrical components and an added NBC system. M109A5 howitzers have been updated from the M109A4 models. In addition to all M109A4 updates, the M109A5 model also modifies the M185 cannon assembly to an M284 cannon assembly and M178 mount to an M182 mount.

The maintenance procedures in this manual will call the mechanic's attention to any differences in cab components which will affect the mechanic's performance of unit maintenance tasks. Where parts which must be removed or inspected differ significantly in appearance, a cutaway view will be used to show the alternate parts.

Part differences not relevant to the unit mechanic will not be mentioned or pictured.

Below are some examples of cab component differences important to the unit mechanic.

<u>Functional group and part</u>	<u>Number of Variations</u>	<u>How assemblies/parts differ</u>
00 Protective shields, race ring	3	Shields mount on race differently. Some M109A3 howitzers do not have a turret shield behind the commander's seat.
01 Bearing balls	2	Some vehicles have 212 bearing balls mounted on 106 race ring spacers; other vehicles have 213 bearing balls mounted on helical compression springs.
02 Cannon assembly, howitzer	2	M109A2/M109A3/M109A4 howitzers have M185 cannon assembly with M35 firing mechanism. M109A5 howitzers have M284 cannon assembly with M49 firing mechanism. Cannon assemblies are similar in maintenance characteristics, but there are subtle differences in parts. Refer to TM 9-2350-311-24P-2 for specific part number changes.  Carrier assembly on M284 cannon assembly has a spring-loaded plunger assembly. The plunger assembly on the M185 cannon assembly is not spring-loaded.



**1-15 DIFFERENCES BETWEEN MODELS — CONTINUED**

<u>Functional group and part</u>	<u>Number of Variations</u>	<u>How assemblies/parts differ</u>
02 Mount, howitzer	2	<p>M109A2/M109A3/M109A4 howitzers have M178 mount. M109A5 howitzers have M182 mount. Mounts are similar in maintenance characteristics, although there are subtle differences in parts. Refer to TM 9-2350-311-24P-2 for specific part number changes.</p> <p>An access plate has been added to the cradle of M109A5 howitzers.</p>
03 Cab hydraulics	2	<p>M109A4/M109A5 howitzers have a hydroscopic breather and an air line filter.</p> <p>Clutch valve and attaching hoses have been added to M109A4/M109A5 howitzers.</p>
03 Power pack assembly	2	<p>M109A4/M109A5 howitzers have eliminated internal hydraulic filter of M109A2 and M109A3 howitzers, replacing it with two external filters.</p>
05 Power lead assembly	2	<p>Number of leads is 3 or 5 depending on number of contact arm assemblies in vehicle. An additional lead for NBC control box was added to M109A4/M109A5 howitzers.</p>
05 NBC power lead assembly	2	<p>M109A4/M109A5 howitzers have an NBC power lead assembly.</p>
05 Power relay box to intercom power supply lead assembly	2	<p>Number of leads differs. One harness used for vehicles with 5 contact arm assemblies; other harness used for vehicles with 3 contact arm assemblies.</p>
06 Contact arm assemblies	2	<p>Some M109A3 vehicles have 3 and some vehicles have 5 contact arm assemblies (slip ring brush holders). M109A2/M109A4/M109A5 vehicles have 5 contact arm assemblies.</p>

<u>Functional group and part</u>	<u>Number of Variations</u>	<u>How assemblies/parts differ</u>
06 Electrical contact segment	2	Segment ring for vehicle with 3 contact arm assemblies has more attaching hardware than segment ring on vehicles having 5 contact arm assemblies. Also, vehicles with 3 contact arm assemblies have a segment ring cover. Vehicles with 5 contact arm assemblies have no segment ring cover.
09 Traversing mechanism	2	M109A4/M019A5 howitzers have modified traversing mechanisms. The electric clutch has been replaced by a hydraulic clutch, the brush assembly has been eliminated, and a clutch valve replaces it. A different hand-wheel is also used.
10 Commander's cupola	2	On earlier design vehicles, the cupola can be opened from both the inside and outside. On later design vehicles, the cupola can be opened only from the inside. Some earlier design vehicles allow rotation of the cupola by loosening a ring lock. On later design vehicles, the cupola can be rotated by pulling out a latch and by placing the latch into one of ten notches to fix the cupola into position.
11 Commander's seat handle latch	2	Some early design vehicles have a short handle on the commander's seat assembly, and some vehicles have a long handle.
12 Gunner's escape hatch	2	On later design vehicles, the escape hatch is opened by pushing a knob and turning a handle.
17 NBC system	2	NBC system is provided only on M109A4 /M109A5 howitzers.

## 1-16 EQUIPMENT DATA

### GENERAL

Length with muzzle brake .....	262.61 in. (6.67 m) (M185) 264.31 in. (6.71 m) (M284)
Muzzle brake, double baffle weight .....	350 lbs (159 kg)
Mount designation .....	M178 or M182
Type of mount .....	Hydro-pneumatic recoil
Recoil length .....	24 to 36 in. (61 to 91 cm)
Elevation .....	+1333 mils
Depression .....	-53 mils
Traverse (left or right) .....	6400 mils
Weight (with cannon and mount) .....	4320 lbs (1960 kg) (M185) 4390 lbs (1991 kg) (M284)

### HYDRAULIC SYSTEM

Capacity .....	10 gal (37.9 l)
----------------	-----------------

### ELECTRICAL SYSTEM

Voltage .....	24 volts, DC, 100 amps (M109A2/M109A3) 180 amps (M109A4/M109A5)
---------------	--

### PRIMARY ARMAMENT (TWO CONFIGURATIONS)\*

Cannon designation .....	M185 or M284
Bore diameter .....	155 mm
Projectile travel in tube .....	200 in. (5.08 m)
Rifling .....	(one turn in 20 calibers; uniform right-hand twist, 48 grooves)

### SECONDARY ARMAMENT

Machine gun .....	caliber 50, M2, heavy barrel, flexible
-------------------	--

\*M109A2/M109A3/M109A4 howitzers have an M185 cannon assembly with M178 mount. M109A5 howitzers have an M284 cannon assembly with M182 mount. However all data listed applies to both configurations unless specified otherwise.

AMMUNITION

155MM conventional. . . . . 34 rounds  
 .50 cal. . . . . 500 rounds

SIGHTING AND FIRE CONTROL EQUIPMENT

M117/M117A2 Panoramic Telescope:

Power . . . . . 4X  
 Field of view . . . . . 170 mils  
 Movement:  
     Azimuth . . . . . 6400 mils  
     Incremental reading (azimuth) . . . . . 1/4 mil  
     Correction (azimuth) . . . . . ±50 mils  
     Elevation . . . . . ±300 mils  
     Weight . . . . . 15 lbs (6.8 kg)

M145/M145A1 Telescope Mount:

Length . . . . . 21 in. (53.3 cm)  
 Width (with attaching bolts) . . . . . 20-1/2 in. (52 cm)  
 Height . . . . . 20-1/2 in. (52 cm)  
 Weight (including linkage assembly) . . . . . 127 lbs (58 kg)  
 Movement:  
     Elevation . . . . . -53 to +1333 mils  
     Incremental reading (counters) . . . . . 1 mil  
     Correction (elevation) . . . . . +50 mils  
     Cross-level adjustment . . . . . ±177 mils  
     Pitch adjustment . . . . . ±177 mils

M118A2/M118A3 Elbow Telescope:

Power . . . . . 4X  
 Field of view . . . . . 177 mils  
 Weight . . . . . 55 lbs (24.9 kg)

---

**1-16 EQUIPMENT DATA — CONTINUED**

---

M118A2/M118A3 Elbow Telescope — Continued:

Movement:

Axial cant correction .....	89 mils
Mirror level .....	1777 mils
Eyepiece arm (operative range) .....	355 mils

■ M1A1/M1A2 Collimator:

Field of view (total) .....	200 mils
Clear aperture .....	3 in. (7.6 cm)
Weight (with cover) .....	24-1/4 lb (11 kg)

■ M140/M140A1 Alinement Device:

Height .....	11 in. (27.9 cm)
Weight .....	1.5 lb (0.68 kg)
Movement .....	0

M146 Telescope Mount:

Length .....	19-7/8 in. (50.5 cm)
Width .....	6 in. (15.2 cm)
Height .....	6-1/4 in. (15.9 cm)
Weight .....	33 lb (15 kg)

Movement:

Azimuth .....	±10 mils
Elevation .....	±10 mils

M15 Elevation Quadrant:

Weight .....	23-1/4 lb (10.5 kg)
--------------	---------------------

Movement:

Elevation (minimum limits) .....	-228 to +1383 mils
Correction (elevation) .....	±55 mils

Cross-level adjustment ..... ±334 mils  
 Incremental reading (counters) ..... 1 mil

M42 Tank Periscope:

Height ..... 10-1/4 in. (5.51 cm)  
 Weight ..... 8 lb (3.363 kg)  
 Length ..... 5-1/2 in. (13.97 cm)  
 Width ..... 5 in. (12.7 cm)

**1-17 EQUIPMENT CONFIGURATION**

Not applicable.

**Section III. PRINCIPLES OF OPERATION**

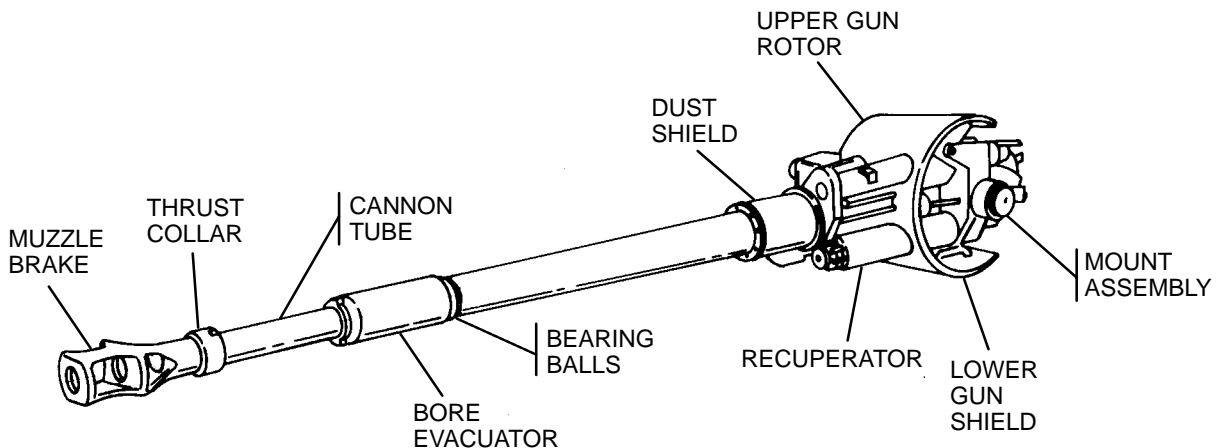
The purpose of Section III is to familiarize the mechanic with the basic operating capabilities of the howitzer cab. The systems covered in this section are the armament, fire control, elevating and traversing systems, NBC system, and related components.

This section will provide information needed to understand instructions on how to service, test, and maintain the cab systems. The functions of each system are presented separately. However, information is also given on how the different cab systems work together so that the mechanic can understand equipment operation. Separate explanations are given for cab systems which require both electrical and hydraulic power to operate. Functional diagrams are included to show how the components of each cab system work together.

**1-18 EQUIPMENT OPERATION AND DESCRIPTION**

**1-18.1 Mount and Howitzer Assembly**

A 155 mm cannon assembly is the primary armament for the M109 series howitzer. M185 cannon assembly is used on M109A2/M109A3/M109A4 howitzers. M284 cannon assembly is used on M109A5 howitzers (para 1-15).



## 1-18 EQUIPMENT OPERATION AND DESCRIPTION — CONTINUED

### 1-18.1 Mount and Howitzer Assembly — Continued

Characteristics:

Loaded hydraulically or manually

Fired manually

Elevated and depressed either manually or hydraulically

Traversed 6400 mils by traversing the cab. Traversing is accomplished either hydraulically or manually.

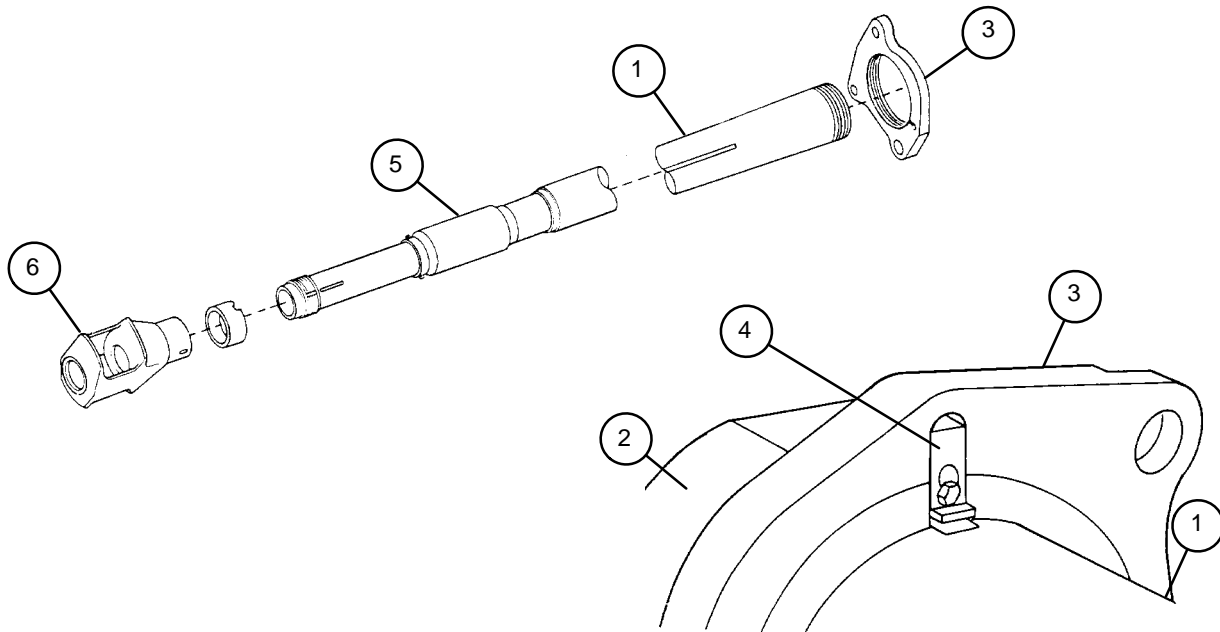
Major Components:

M178 mount assembly (used with M185 cannon assembly) or M182 mount assembly (used with M284 cannon assembly)

Tube assembly/cannon assembly

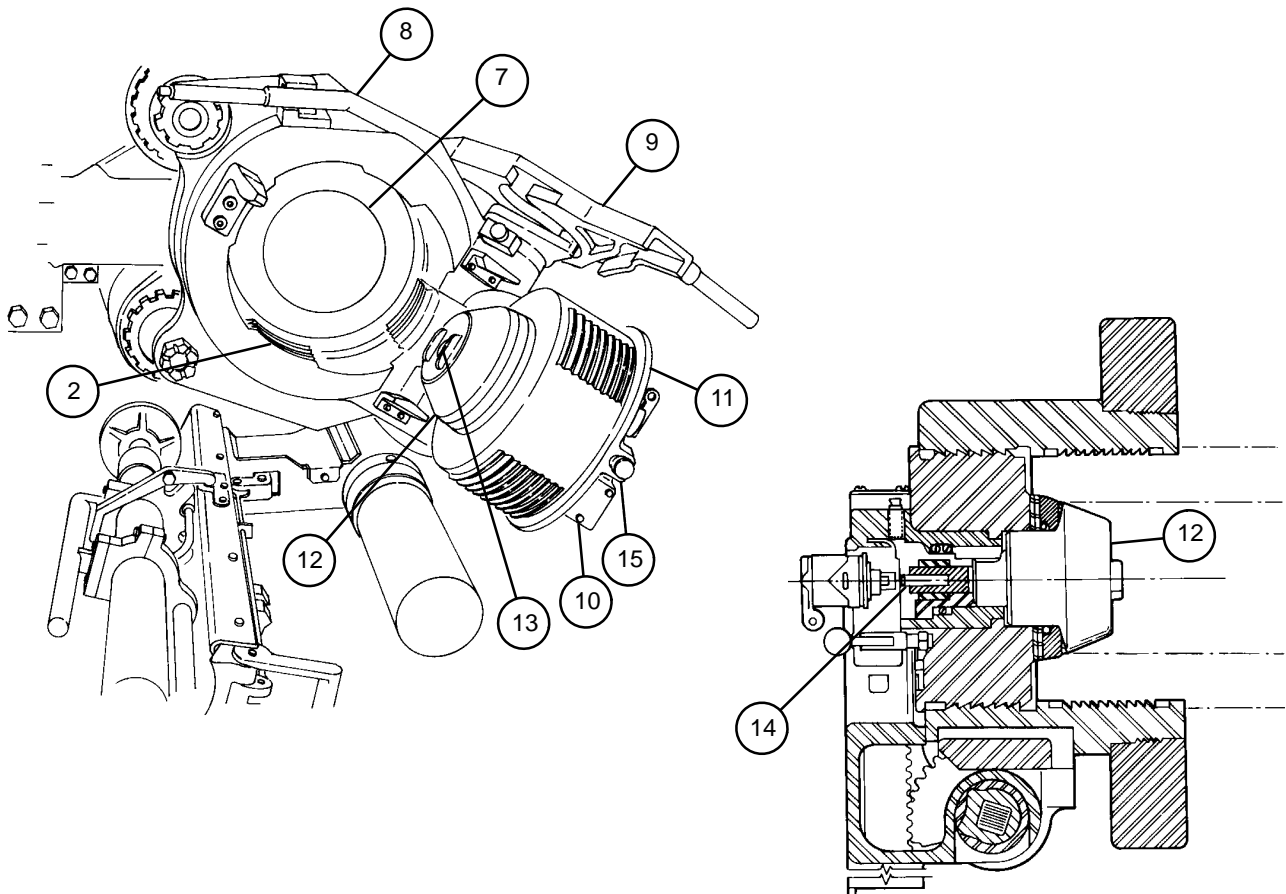
a. Tube Assembly/Cannon Assembly

- 1 CANNON TUBE. The cannon tube (1) serves as the chamber for the projectile. Rifled bore ensures accurate projectile trajectory. Cannon tube mounts on inside of breech ring (2). Cannon tube locks inside breech ring band (3) by means of interrupted threads and breech ring key (4).
- 2 BREECH RING KEY. The breech ring key (4) holds cannon tube (1) in correct position on breech ring (2). The breech ring key prevents the cannon tube from turning and unlocking from interrupted threads.
- 3 BORE EVACUATOR. The bore evacuator (5) helps clear the cannon tube (1) of gases after firing, minimizing the contamination of the air within the cab.
- 4 MUZZLE BRAKE. The muzzle brake (6) reduces the force of recoil and forward flash, and deflects gases away from the cab.



## b. Breech Assembly

- 1 CHAMBER. The chamber (7) holds powder charge.
- 2 OPERATING HANDLE. The operating handle (8) is used to open the breech manually. The breech opening mechanism consists of the breech operating cam (9), operating handle (8), and carrier assembly (10). As the cannon assembly returns to battery, the combined operation of the operating crank, the cam, and the carrier assembly open the breechblock (11).
- 3 BREECHBLOCK ASSEMBLY. The breechblock (11) locks into place behind the chamber (7) holding the powder charge. On closing, the breechblock threads engage with the threads of the breech ring (2). When these threads are engaged, they lock the breechblock in place.
- 4 SPINDLE ASSEMBLY. The spindle assembly (12) seals the powder chamber to prevent escape of gases into the cab.
- 5 VENT HOLE. The vent hole (13) directs the primer blast against the base of the powder charge.
- 6 PRIMER CHAMBER. The primer chamber (14) holds the primer in place for firing.
- 7 FIRING GROUP BLOCK. The firing group block (15) slides over the primer and positions the M35 firing mechanism (on M185 cannon assembly) or M49 firing mechanism (on M284 cannon assembly) for firing.



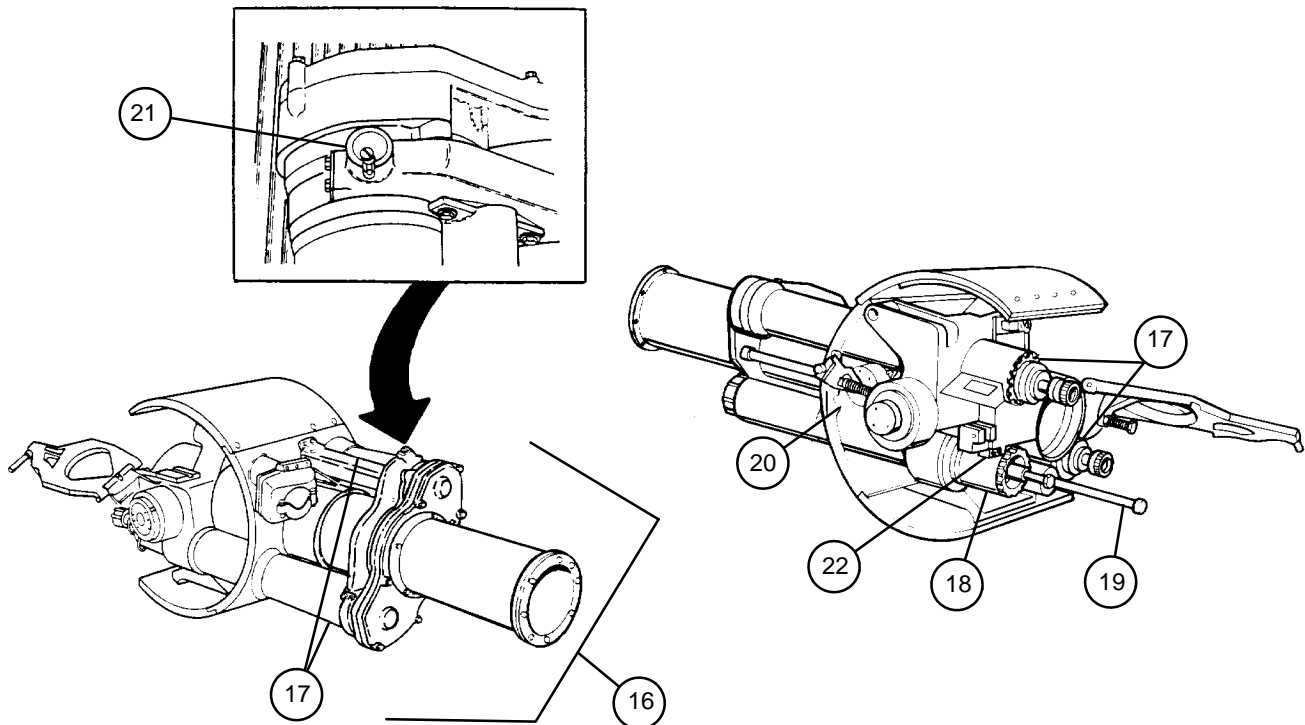


## 1-18 EQUIPMENT OPERATION AND DESCRIPTION — CONTINUED

### 1-18.1 Mount and Howitzer Assembly — Continued

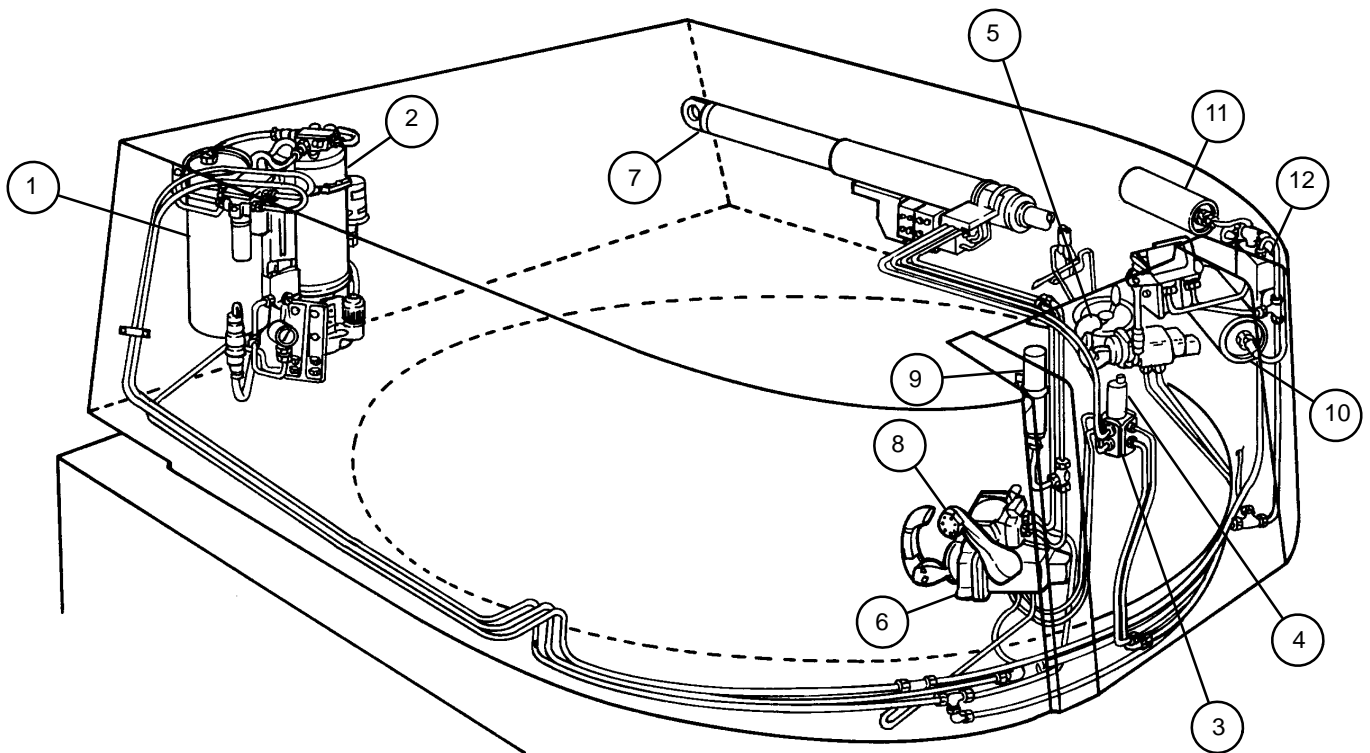
#### a. Mount Assembly

- 1 MOUNT. The mount (16) serves as a fulcrum for the elevation and depression of the cannon assembly. The breech ring band (para 1-18.1a.) connects to the mount by means of recoil cylinder rods.
- 2 VARIABLE RECOIL MECHANISM. The variable recoil mechanism (17) absorbs and reduces the recoil force of the cannon assembly.
- 3 RECUPERATOR. The recuperator (18) returns the cannon tube to battery after firing.
- 4 COUNTER RECOIL BUFFER ASSEMBLY. The counter recoil buffer assembly (19) absorbs shock; slows and cushions the cannon assembly as it returns to battery.
- 5 ACTUATOR. The actuator (20) adjusts recoil position depending on cannon elevation. Allows longer recoil at low elevation and short recoil for high elevation.
- 6 BLEEDER VALVE, VARIABLE RECOIL CYLINDER. The bleeder valve (21) is used to purge air from the recoil mechanism.
- 7 BUFFER BLEED BLOCK PLUG. The buffer bleed block plug (22) is used to purge counterrecoil buffer.



### 1-18.2 Elevating System

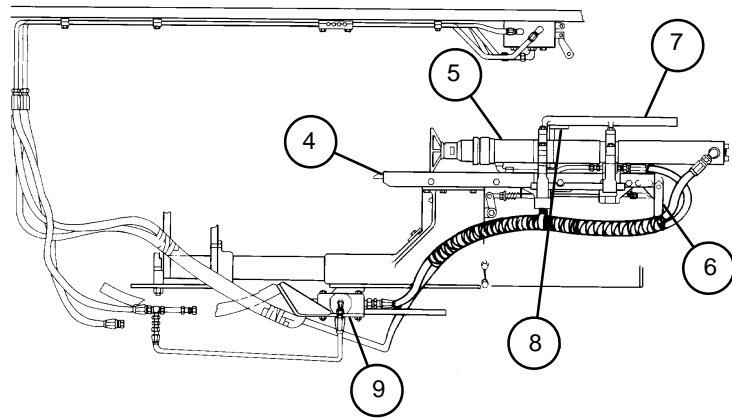
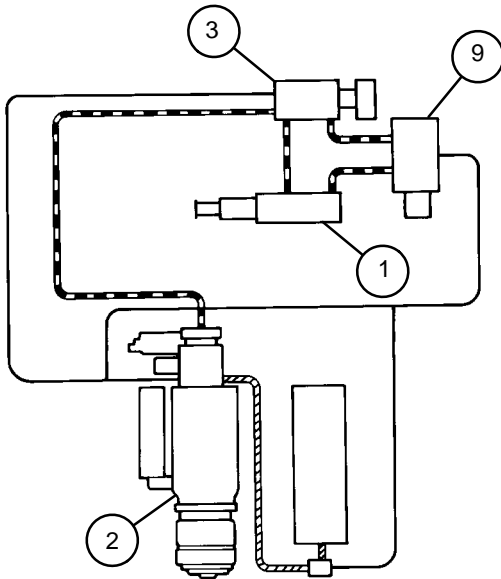
- a. MAIN ACCUMULATOR AND POWER PACK ASSEMBLY. The main accumulator (1) and power pack assembly (2) provide hydraulic power to cab components through a network of lines and control valves.
- b. SELECTOR VALVE ASSEMBLY AND SOLENOID. The selector valve assembly (3) and solenoid (4) direct hydraulic flow from either the gunner's control handle (5) or assistant gunner's control handle (6) to the equilibrated elevating cylinder (7).
- c. GUNNER'S CONTROL HANDLE. The gunner's control handle (5) receives hydraulic power from power pack (2) to elevate or depress the cannon and traverses cab left or right.
- d. ASSISTANT GUNNER'S CONTROL HANDLE. The assistant gunner's control handle (6) receives hydraulic power from the power pack (2) to elevate or depress cannon.
- e. MANUAL ELEVATING HAND PUMP. The manual elevation hand pump (8) directs hydraulic flow to elevate and depress the cannon manually.
- f. MANUAL ELEVATION ACCUMULATOR. The manual elevation accumulator (9) maintains hydraulic fluid in manual elevation hand pump (8) under minimum pressure to permit manual control of cannon elevation and depression.
- g. EQUILIBRATED ELEVATING CYLINDER. The equilibrated elevating cylinder (7) elevates, depresses, and balances cannon; as well as compensates for uneven distribution of weight of cannon tube. Other components of equilibration system are the primary accumulator assembly (10), secondary accumulator assembly (11), equilibration manifold assembly (12), and manual elevation hand pump (8).





## 1-18 EQUIPMENT OPERATION AND DESCRIPTION — CONTINUED

### 1-18.3 Rammer Hydraulic System

- a. **RAMMER ASSEMBLY.** The rammer assembly (1) is used for loading and ramming the projectile into the cannon tube. Hydraulic power from the power pack assembly (2) flows through the valve assembly to the rammer cylinder which uses the pressure to ram the projectile into position.
- b. **ACTUATING VALVE.** The actuating valve (3) controls the inflow of hydraulic oil for the ramming operation and outflow of hydraulic oil for the retraction of the rammer (1) after use.
- c. **TRAY ASSEMBLY.** The tray assembly (4) holds the projectile in position for ramming.
- d. **CYLINDER ASSEMBLY.** The cylinder assembly (5) contains the piston which rams the projectile into the chamber.
- e. **MAIN RELEASE HANDLE.** The main release handle (6) releases the locking mechanism so that the rammer (1) may be moved into "RAM" position, and also back into "STOW" position.
- f. **HANDLE ASSEMBLY.** The handle assembly (7) provides a hand hold for rotating the rammer cylinder (5) into ramming position.
- g. **CYLINDER LATCH.** The cylinder latch (8) locks the rammer cylinder (5) into position on the tray assembly (4).
- h. **BLOCKING VALVE.** The blocking valve (9) prevents accidental ramming of rammer in stowed position.



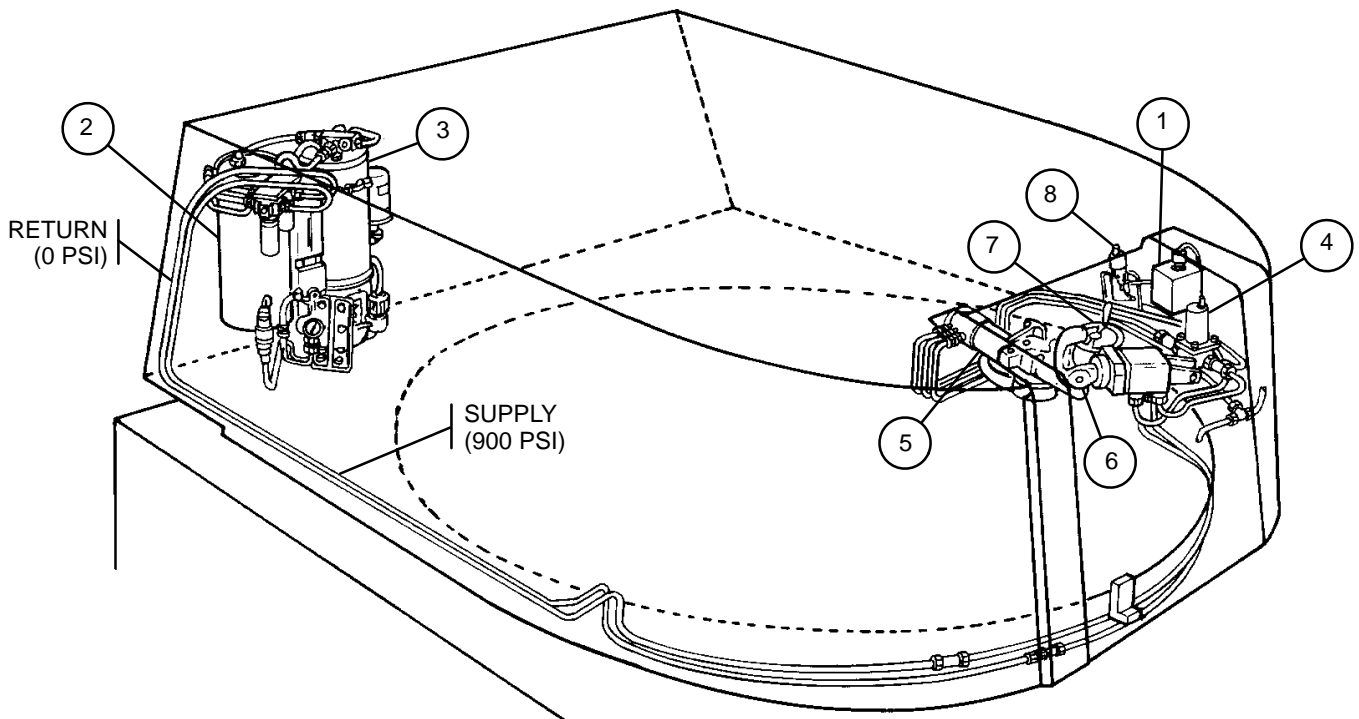
 OPERATING PRESSURE – 900 PSI (6206 kPa)

 DRAIN RESERVOIR PRESSURE – 0 PSI (0 kPa)

 PUMP PRESSURE – 925 – 1225 PSI (6378 – 8446 kPa)

### 1-18.4 Cab Traversing System

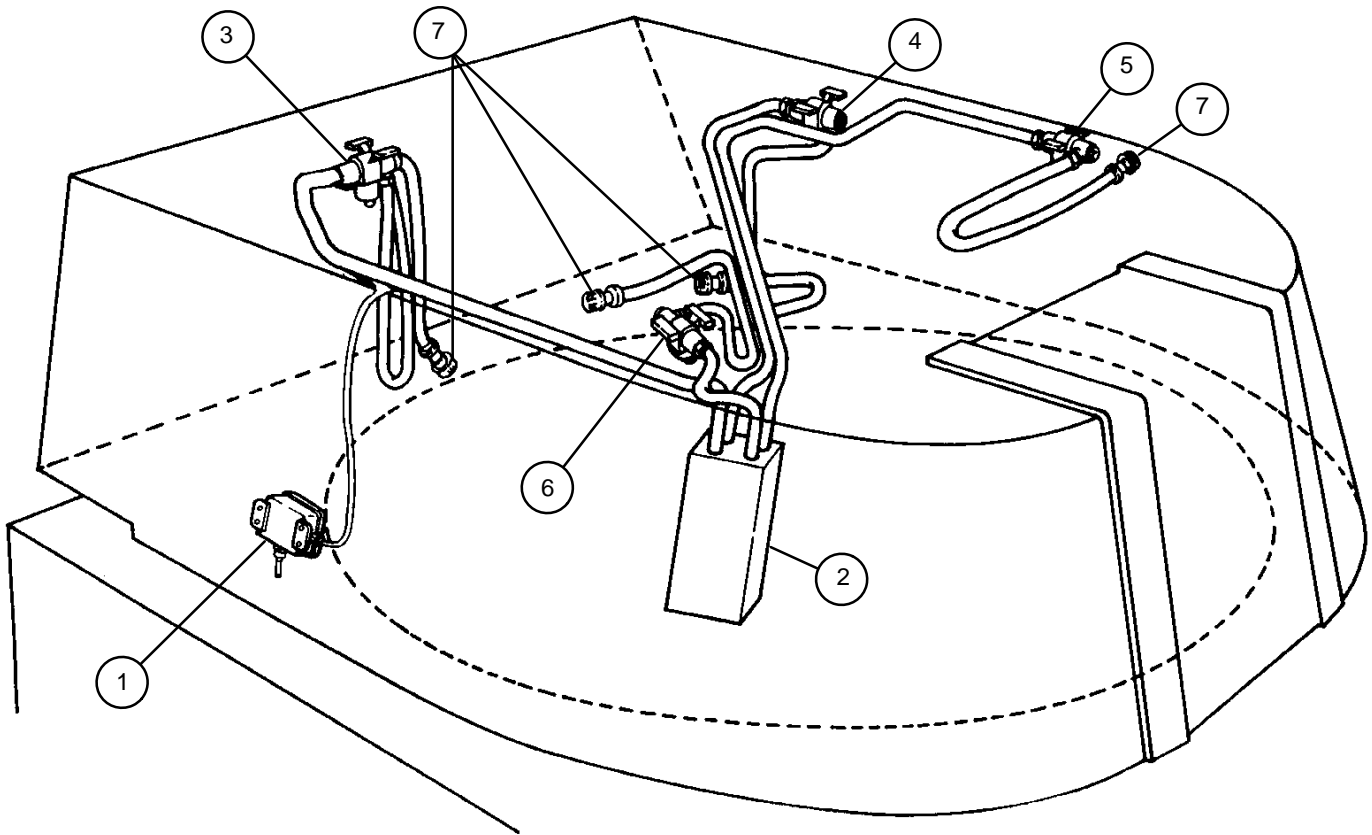
- a. GUNNER'S SELECTOR SWITCH BOX ASSEMBLY. The gunner's selector switch box assembly (1) has positions for either power or manual traverse of cab.
- b. MAIN ACCUMULATOR AND POWER PACK ASSEMBLY. The main accumulator (2) and power pack assembly (3) deliver hydraulic power to cab components through a network of lines and control valves.
- c. BY-PASS VALVE ASSEMBLY AND SOLENOID. The by-pass valve assembly and solenoid (4) direct hydraulic flow to allow manual or power traversing.
- d. TRAVERSING MECHANISM. The traversing mechanism (5) traverses the cab by hydraulic power or mechanical energy. Clutch mechanism controlled by gunner's selector switch box assembly (1) disengages manual gears and allows power traversing.
- e. GUNNER'S CONTROL HANDLE. The gunner's control handle (6) receives hydraulic power from the power pack assembly (3) and uses the power to either traverse the cab right and left, or elevate or depress the gun.
- f. MANUAL TRAVERSE HANDWHEEL. The manual traverse handwheel (7) allows manual traverse of cab.
- g. CLUTCH VALVE (M109A4/M109A5 ONLY). The clutch valve (8) allows power traversing in the event of electrical failure by activating the clutch valve manually.



1-18 EQUIPMENT OPERATION AND DESCRIPTION — CONTINUED

1-18.5 NBC System (M109A4/M109A5 Only)

- a. NBC CONTROL BOX ASSEMBLY. The NBC control box assembly (1) located at commander's station turns the NBC system on and off.
- b. M2A2 AIR PURIFIER. The M2A2 air purifier (2) pulls contaminated air through gas and particulate filters and distributes clean air through hoses to individual M3 electrical air heaters.
- c. M3 ELECTRIC AIR HEATERS. The section chief's heater (3), cannoneer no. 1's heater (4), gunner's heater (5), and assistant gunner's heater (6) located on the cab ceiling, warm filtered air for individual crew member's comfort.
- d. ORIFICE CONNECTORS. The orifice connectors (7) attach purification system to M25A1 field protective masks.



## CHAPTER 2

# GENERAL CAB MAINTENANCE

### GENERAL

The purpose of this chapter is to provide information needed to keep the M109A2/M109A3/M109A4/M109A5 howitzer cab systems and components in good repair. Section I provides information on tools and repair parts. Section II details actions which must be taken when the equipment is received and installed. Section III prescribes Preventive Maintenance Checks and Services (PMCS) for the unit level. Section IV gives general maintenance procedures in a number of areas including replacing parts, soldering, correct cleaning procedures, painting, and application of adhesives. Section V details actions that must be taken when the equipment is stored or shipped.

<u>CONTENTS</u>	<u>Page</u>
Section I	REPAIR PARTS, TOOLS, SPECIAL TOOLS, TEST, MEASUREMENT, AND DIAGNOSTIC EQUIPMENT (TMDE), AND SUPPORT EQUIPMENT
2-1	COMMON TOOLS AND EQUIPMENT ..... 2-2
2-2	SPECIAL TOOLS, TMDE, AND SUPPORT EQUIPMENT ..... 2-2
2-3	REPAIR PARTS ..... 2-2
Section II	SERVICE UPON RECEIPT
2-4	SERVICE UPON RECEIPT OF MATERIEL ..... 2-3
2-5	ASSEMBLY OF EQUIPMENT ..... 2-10
2-6	PRELIMINARY SERVICING AND ADJUSTMENT OF EQUIPMENT ..... 2-14
2-7	DECALS, LABELS, AND INSTRUCTION SIGNS ..... 2-15
Section III	PREVENTIVE MAINTENANCE CHECKS AND SERVICES (PMCS), LUBRICATION INSTRUCTIONS, AND MANDATORY REPLACEMENT PARTS
2-8	LUBRICATION ..... 2-18
2-9	PREVENTIVE MAINTENANCE CHECKS AND SERVICES (PMCS) ..... 2-21
Section IV	GENERAL MAINTENANCE PROCEDURES
2-10	DISASSEMBLY AND ASSEMBLY PROCEDURES ..... 2-33
2-11	REPLACEMENT OF PARTS ..... 2-33
2-12	CLEANING ..... 2-34
2-13	INSPECTION ..... 2-36
2-14	GENERAL REPAIR PRACTICES ..... 2-37
2-15	WELDING ..... 2-37
2-16	SOLDERING ..... 2-38
2-17	APPLICATION OF ADHESIVES ..... 2-39
2-18	EXERCISING HYDRAULIC COMPONENTS ..... 2-40
Section V	PREPARATION FOR STORAGE OR SHIPMENT
2-19	GENERAL ..... 2-40
2-20	PRELIMINARY REQUIREMENTS ..... 2-41
2-21	RECEIPT FOR STORAGE ..... 2-41
2-22	SECURITY ..... 2-41
2-23	STORAGE SITE ..... 2-42

<u>CONTENTS</u>	<u>Page</u>
2-24 STORAGE PLAN .....	2-42
2-25 AUXILIARY EQUIPMENT AND BASIC ISSUE ITEMS .....	2-42
2-26 GENERAL CLEANING, PAINTING, AND PRESERVATION .....	2-42
2-27 PREPARATION OF CANNON, FIRE CONTROL INSTRUMENTS, AND AUTOMOTIVE EQUIPMENT .....	2-43
2-28 CARE OF EQUIPMENT IN ADMINISTRATIVE STORAGE .....	2-44
2-29 INSPECTION .....	2-44
2-30 EXERCISING .....	2-45
2-31 ROTATION .....	2-45
2-32 REMOVAL FROM ADMINISTRATIVE STORAGE .....	2-46
2-33 SERVICING .....	2-46
2-34 SHIPPING PREPARATION .....	2-46
2-35 LOADING VEHICLE FOR SHIPMENT .....	2-47
2-36 BLOCKING .....	2-47

---

**Section I. REPAIR PARTS, TOOLS, SPECIAL TOOLS, TEST, MEASUREMENT, AND DIAGNOSTIC EQUIPMENT (TMDE), AND SUPPORT EQUIPMENT**

---

**2-1 COMMON TOOLS AND EQUIPMENT**

---

- a. For authorized common tools and equipment, refer to the Modified Table of Organization and Equipment (MTOE), CTA 50-970, or CTA 8-100, as applicable to your unit.
  - b. The tool kit assigned to the mechanic for performance of maintenance procedures is the Artillery and Turret Mechanic's Tool Kit (SC 5180-95-CL-A12). Other tools required for performance of unit level maintenance procedures are identified in the initial setup with a reference to Appendix H, Tool Identification List.
- 

**2-2 SPECIAL TOOLS, TMDE, AND SUPPORT EQUIPMENT**

---

Special tools required for unit maintenance of the cab are listed in Appendix B, the Maintenance Allocation Chart, for information only. This list is not to be used for requisitioning parts.

Special tools can be ordered using the information contained in the Repair Parts and Special Tools List (RPSTL) (TM 9-2350-311-24P-2). Fabricated tools required for unit maintenance of the cab are listed in Appendix E, Illustrated List of Manufactured Items.

---

**2-3 REPAIR PARTS**

---

Repair parts are listed and illustrated in the Repair Parts and Special Tools List (RPSTL) (TM 9-2350-311-24P-2) covering unit maintenance for this equipment.

Mandatory replacement parts for unit maintenance of the cab are identified in the initial setup, with a reference to Appendix G, Mandatory Replacement Parts List.

---

## Section II. SERVICE UPON RECEIPT

---

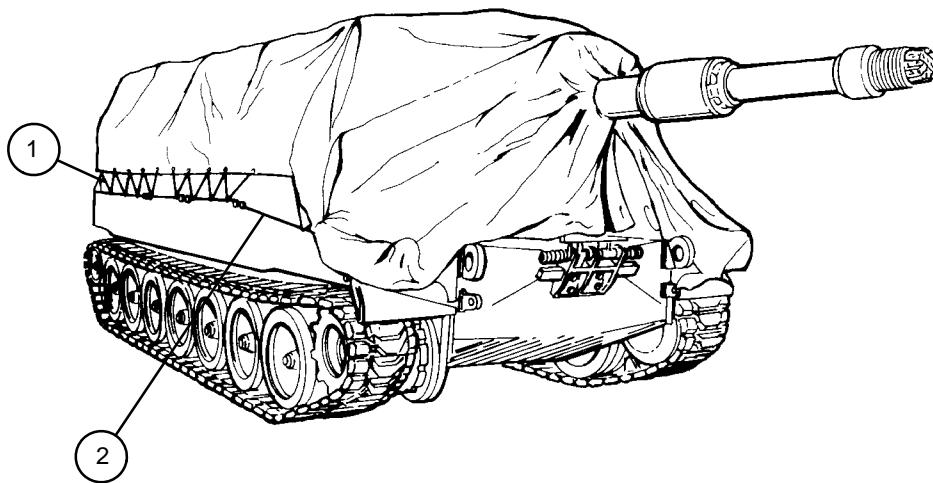
### 2-4 SERVICE UPON RECEIPT OF MATERIAL

---

#### 2-4.1 Unpacking

##### a. Removal of Closure Kit

- 1 Loosen side rope (1) (two on each side).
- 2 Remove tie-down ropes at rear of vehicle.
- 3 Remove corner ropes at rear of vehicle.
- 4 Untie front corner ropes (2).
- 5 Remove vehicle front ropes.
- 6 Unlace ropes from front eyelets.
- 7 Unlace ropes from eyelets on front covers.
- 8 Remove guide ropes from side wire struts.
- 9 Remove all ropes from eyelets.





---

## 2-4 SERVICE UPON RECEIPT OF MATERIAL — CONTINUED

---

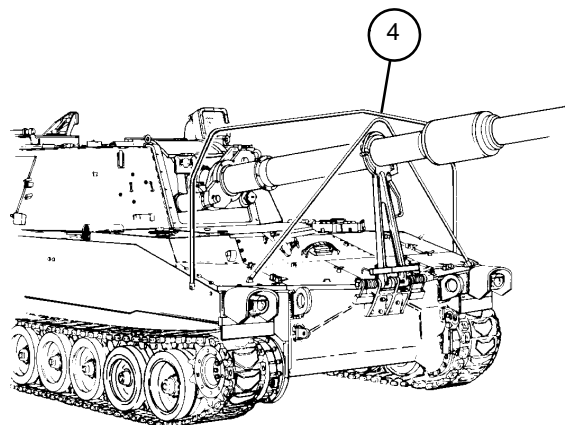
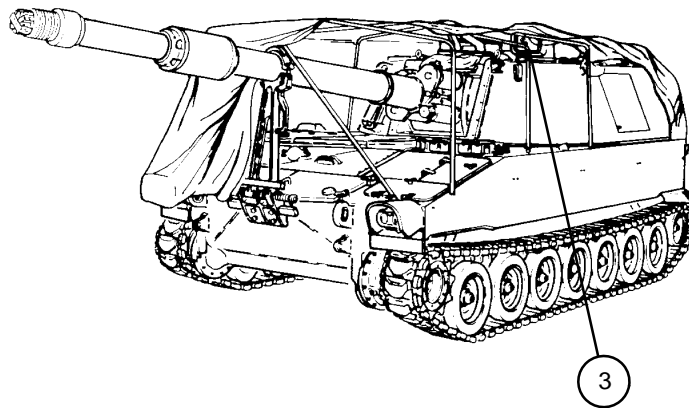
### 2-4.1 Unpacking — Continued

- 10 Fold cover on side to center point (3) of frame assembly (4) and remove cover.

#### NOTE

Save screws removed from rear cab frame bracket for use when installing baskets.

- 11 Remove screws and lockwashers holding on frame assembly (4). Discard lockwashers.
- 12 Remove frame assembly (4).



- 13 Remove padding (5) from extend points.
- 14 Remove tape from end of 155 mm cannon tube (6). Clean and install muzzle brake (7) (TM 9-2350-311-10).

**NOTE**

Springs densely packed with grease will prevent breechblock from opening.

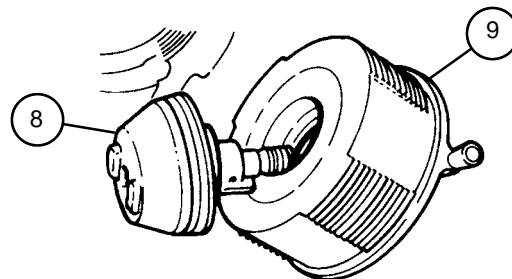
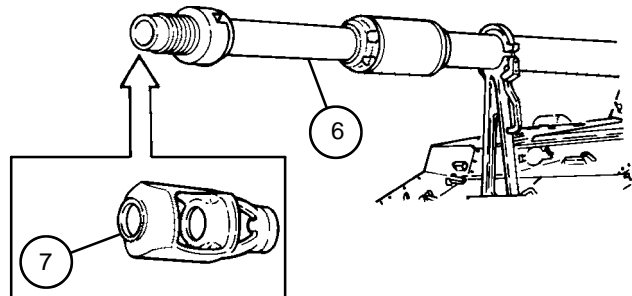
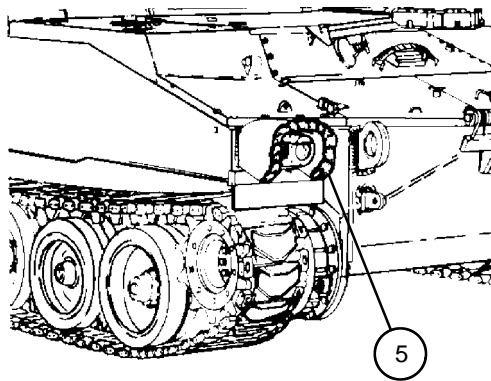
- 15 If breechblock will not open or if it opens with great difficulty, clean rack springs (para 2-4.4c.).

b. Unpacking Basic Issue Item Boxes

Remove basic issue item box, uncrate, inventory, and stow (TM 9-2350-311-10).

c. Unpacking Shipping Block

Remove spindle assembly (8) from breechblock (9). Remove wooden shipping block and install rings, obturator pad, and disk (para 5-7).



---

## 2-4 SERVICE UPON RECEIPT OF MATERIAL — CONTINUED

---

### 2-4.2 Cleaning the Vehicle

**WARNING**

- Do not use mineral spirits or paint thinner to clean the howitzer. These cleaning solvents are highly toxic and combustible. Prolonged breathing can cause dizziness, nausea, and even death.
- Solvents can burn easily, can give off harmful vapors, and are harmful to skin and clothing. To avoid injury or death, keep away from open fire and use in well-ventilated area. If solvent gets on skin or clothing, wash immediately with soap and water.

#### NOTE

This section may provide material which is duplicated in TM 9-2350-311-20-1 (howitzer hull manual). However, this duplication is limited only to activities which require crew and maintenance mechanic joint effort.

Armament parts are coated with rust-preventive compound when received from storage. Clean these parts thoroughly with rags or a brush saturated with cleaning compound (item 9.1, Appx D). After complete removal of the rust-preventive compound, lubricate as specified in the PMCS chart (para 2-9) and TM 9-2350-311-10. Component parts of each weapon should be cleaned separately where practicable. Component parts are interchangeable, however, the parts originally assembled work best together. Whenever possible, the vehicle crew will help to perform these services.

### 2-4.3 Checking Unpacked Equipment

- a. Inspect the equipment for damage incurred during shipment. If the equipment has been damaged, report the damage on SF 364, Report of Discrepancy.
- b. Check the equipment against the packing slip to see if the shipment is complete. Report all discrepancies in accordance with the instruction of DA PAM 750-8 or DA PAM 738-751 as applicable.
- c. Check to see whether the equipment has been modified.
- d. Inspect the cab as outlined in the Service Upon Receipt Checklist.

## Service Upon Receipt Checklist – M109 Howitzer Series Cab

LOCATION	ITEM	ACTION	REMARKS/REFERENCES
Cab	1. Armament Cannon Assembly, 155mm, M185 or M284	Clean surface to remove rust-preventive compounds.	para 2-4.2
	2. Surfaces (Interior/Exterior)	Inspect for rust or damage which could render the unit unserviceable.	para 2-13
	3. Panoramic Telescope Ballistic Cover	Uncrate and install panoramic telescope ballistic cover.	Chapter 16
	4. M42 Tank Periscope	Check for evidence of moisture; purge and charge if required.	TM 750-116
	5. M145/M145A1 Panoramic Telescope Mount	Check counter box area for evidence of moisture; purge if required. Check for illumination. Check synchronization.	TM 750-116 TM 9-2350-311-10 para 18-4
	6. M15 Elevation Quadrant	Check counter box area for evidence of moisture; purge if required. Check for illumination.	TM 750-116 TM 9-2350-311-10
	7. M117/M117A2 Panoramic Telescope	Check main telescope and counter box area for evidence of moisture; purge and charge if required. Check for illumination.	TM 750-116 TM 9-2350-311-10
	8. M118A2/M118A3 Elbow Telescope	Check for evidence of moisture; purge and charge if required. Check for illumination.	TM 750-116 TM 9-2350-311-10
	9. Main Accumulator and Power Pack Assembly	Check hydraulic fluid level and system pressure.	para 6-2
	10. Cab Traverse, Howitzer Elevation, and Rammer Systems.	Check operations.	para 2-6
	11. Buffer Rod	Inspect forward section of counter-recoil buffer rod. Clean off all foreign matter.	para 5-17

**2-4 SERVICE UPON RECEIPT OF MATERIAL — CONTINUED**

**Service Upon Receipt Checklist – M109 Howitzer Series Cab — Continued**

LOCATION	ITEM	ACTION	REMARKS/REFERENCES
Cab – cont.	12. Basic Issue Items (Stowed Items)	Uncrate and install or stow.	TM 9-2350-311-10

**WARNING**



The M140 alinement device is radioactively illuminated. Check for loss of luminescence, breakage, damage, or defects. If present, follow the procedures on page b.



The M1A1 collimator is radioactively illuminated. Check for presence of illumination and damage. If discovered broken, damaged, or defective, follow the procedures on page b.

13. M140 Alinement Device	Check for evidence of moisture; purge and charge if required. Check for illumination.	TM 750-116 TM 9-2350-311-10
14. M1A1 Collimator	Check for evidence of moisture; purge and charge if required. Check for illumination.	TM 750-116 TM 9-2350-311-10

**2-4.4 Processing Unpacked Equipment**

- a. Install fire control and sighting equipment. No cleaning is required.
- b. Clean all other tools and equipment.
- c. Removal, Cleaning, and Installation of Rack Springs

**WARNING**

Remove breechblock operating rack springs only when breechblock is in closed position. Springs are under heavy pressure and could cause injury to personnel. Under no circumstances will removal of springs be attempted with breechblock open.

- 1 Removal of rack springs.
  - (a) Push in plunger (1) with punch (SC 5180-95-CL-A12). Slide rack plate (2) rearward (toward bustle) until it disengages from plunger (1).
  - (b) With breechblock closed, drive rack plate (2) rearward. Stop plate (3) and rack springs (4) will now pop out. Use clean rag (item 25, Appx D) to catch stop plate and rack springs.

## 2 Cleaning of rack springs.

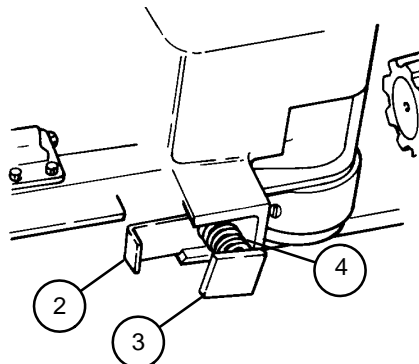
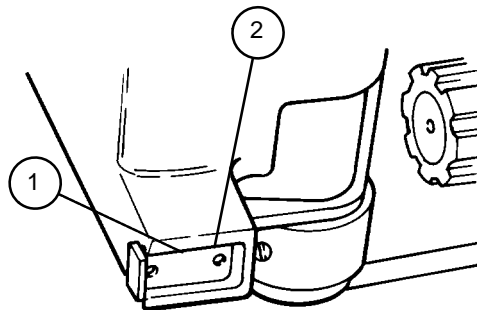
Wipe grease from rack springs (4).

### WARNING

Failure to ensure proper installation of rack springs and plates could cause injury to personnel during operation of breechblock.

## 3 Installation of rack springs.

- (a) Install rack springs (4) and stop plate (3), applying pressure with wooden handle or wooden dowel (item 40, Appx D).
- (b) Slide rack plate (2) forward over stop plate (3). Make sure plunger (1) pops into rearward hole, holding rack plate securely.



---

## 2-5 ASSEMBLY OF EQUIPMENT

---

This section provides instructions for installing items that were unassembled for shipping purposes.

---

### INITIAL SETUP

Tools

Artillery and turret mechanic's tool kit  
(SC 5180-95-CL-A12)

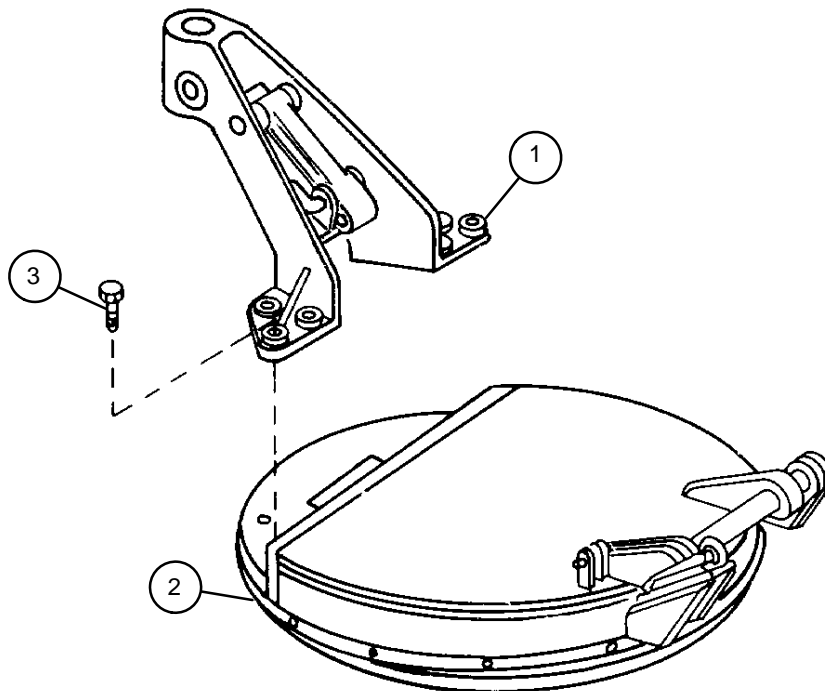
Materials/Parts

Lockwashers (24) (item 87, Appx G)  
Lockwashers (32) (item 60, Appx G)

---

#### 2-5.1 Caliber 50 Machine Gun Mount Support

Secure machine gun mount support (1) to commander's cupola (2) using six cap screws (3).

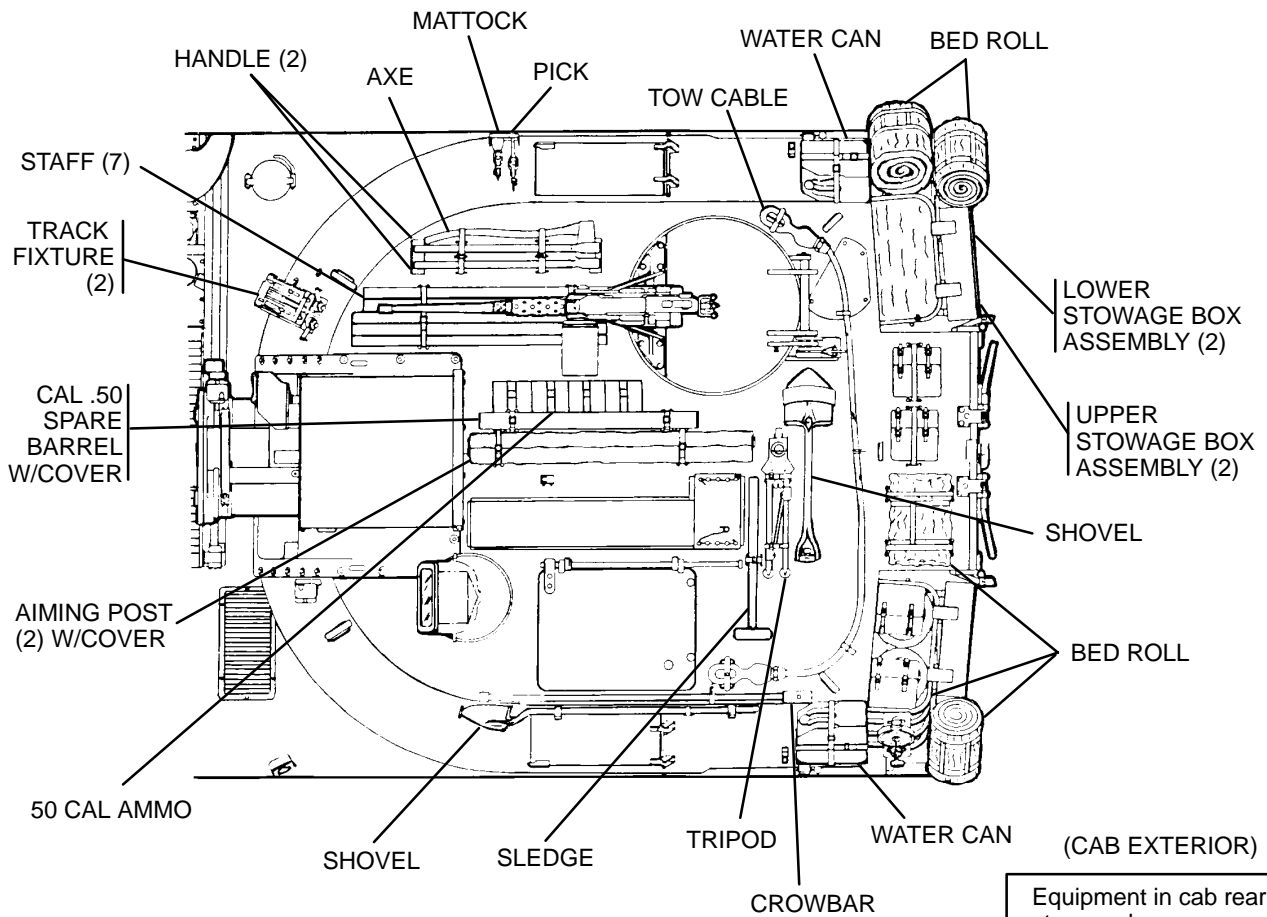


**2-5.2 Panoramic Telescope Ballistic Cover**

Install panoramic telescope ballistic cover (Chapter 16).

**2-5.3 Stowage – External**

a. External Stowed Items Location Index



Equipment in cab rear storage boxes
Lubrication gun, M3
Hatchet
Bore brush
Gun tool roll
Breech boresight
Wire cutter and carrier
Signal marker
Cooking stove
Tube reducer, M3



## 2-5 ASSEMBLY OF EQUIPMENT — CONTINUED

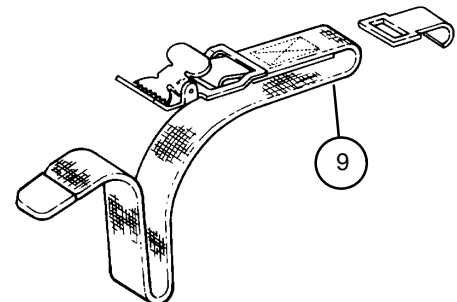
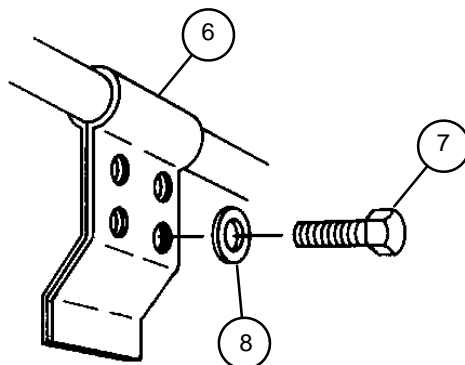
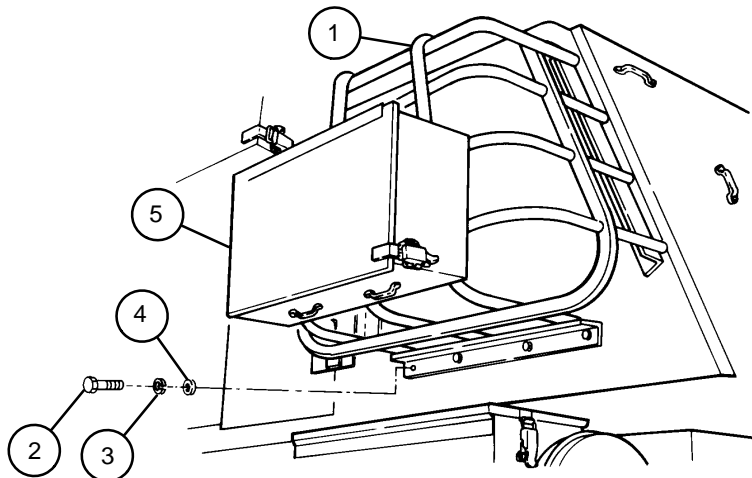
### 2-5.3 Stowage – External — Continued

#### b. Assembly of External Stowage Items

#### NOTE

For step 1, use the screws saved from para 2-4.1a. Additional hardware is packed in bag inside vehicle.

- 1 Secure two baskets (1) to right and left sides of cab bustle. Each basket is secured to cab with 12 cap screws (2), 12 new lockwashers (3), and 12 flat washers (4).
- 2 There are four stowage boxes (5) mounted on two baskets (1). The top box, with shelf (on both sides of bustle), is secured to the second horizontal rib of basket by two retaining straps (6), eight machine bolts (7), and eight new lockwashers (8). The bottom box, without shelf (on both sides of bustle), is secured to the bottom horizontal rib of basket (1). Bottom bracket is staggered by placing support bracket next to outside vertical bar of basket.
- 3 Stowage straps (9) are used to secure all BII to cab surface.

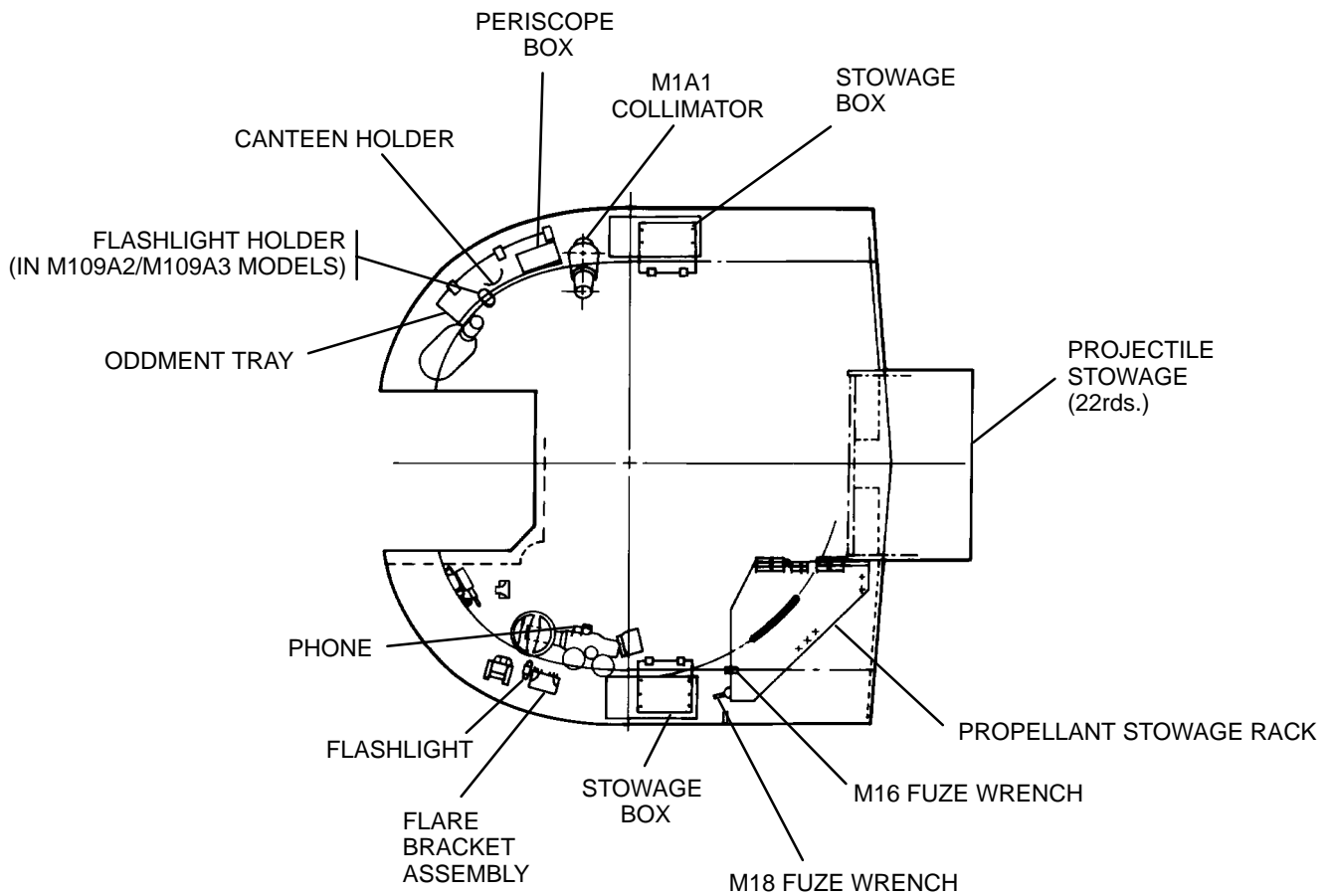


**2-5.4 Internal Stowage**

Follow internal stowed items location index for proper stowage of cab internal items.

**2-5.5 Cable Diagrams**

Refer to FO-1 through FO-4 for electrical/hydraulic schematics for M109A2/M109A3/M109A4/M109A5 howitzers. Appendix I, Hydraulic Schematic Symbols, provides hydraulic symbols as used on the hydraulic schematics. See FO-1 for electrical schematics for M109A2/M109A3 howitzers and FO-2 for electrical schematics for the M109A4/M109A5 howitzers. See FO-3 for hydraulic system schematic for M109A2/M109A3 howitzers, and FO-4 for hydraulic system schematic for M109A4/M109A5 howitzers.



INTERNAL STOWED ITEMS LOCATION INDEX

---

## 2-6 PRELIMINARY SERVICING AND ADJUSTMENT OF EQUIPMENT

---

### 2-6.1 Electrical Connections

All electrical interconnections will have an overall inspection accomplished. This is to include wiring harnesses, connectors, and groundings. These are discussed in Chapter 8, Cab Electrical System.

### 2-6.2 Fluid and Pressure Checks

Certain checks must be accomplished before the system may be considered operational.

#### NOTE

Park vehicle on level ground if possible when performing this check.

- a. Cab Hydraulic Power Pack Assembly. Check hydraulic fluid level (para 6-2).
- b. Main Accumulator. Check nitrogen precharged pressure (para 6-10).
- c. Cab Traverse. Operate and check for hydraulic leaks.
- d. 155 MM Cannon Tube Elevation/Depression. Operate and check for ease of operation (smooth cannon tube travel up and down) and for hydraulic leaks (para 2-9.4). Have a crew member observe variable recoil linkage for rotation (TM 9-2350-311-10).
- e. Projectile Rammer. Check for hydraulic leaks (para 2-9.4).
- f. Rammer. Perform reliability checks (para 7-3).

### 2-6.3 Cab Hydraulics

Check the cab traverse, equilibrated elevation, and rammer systems for correct operation (TM 9-2350-311-10) and for hydraulic leaks. Adjustment procedures for the equilibrated elevation system are discussed in Chapter 6. Adjustment procedures for the projectile rammer are discussed in Chapter 7.

### 2-6.4 Fire Control

- a. Boresight fire control in accordance with TM 9-2350-311-10.
- b. Make sure M1A1 collimator is still illuminated.

### 2-6.5 Lubrication

Lubricate equipment as directed by the PMCS chart (para 2-9), TM 9-2350-311-20-1, and TM 9-2350-311-10.

## 2–7 DECALS, LABELS, AND INSTRUCTION SIGNS

This task covers: a. Removal b. Installation

### INITIAL SETUP

Tools

Artillery and turret mechanic's tool kit  
(SC 5180–95–CL–A12)

Cleaning compound (item 9.1, Appx D)

Instruction sign

Label

Materials/Parts

Decal

### a. Removal

#### NOTE

- Only replace decals, labels, and instruction plates which are damaged or unreadable.
  - Perform step 1 for self-adhesive decals, labels, and instruction plates.
  - Perform step 2 for plates with hardware.
- 1 Scrape label from mounting surface. Discard label.
  - 2 Remove all screws and washers securing instruction plate to mounting surface. Retain screws and washers for assembly.

### b. Installation

<b>WARNING</b>
----------------

Solvents can burn easily, can give off harmful vapors, and are harmful to skin and clothing. To avoid injury or death, keep away from open fire and use in well-ventilated area. If solvent gets on skin or clothing, wash immediately with soap and water.

#### NOTE

- Perform steps 1 through 3 for self-adhesive decals, labels, and instruction plates.
  - Perform step 4 for instruction plates with hardware.
- 1 Clean mounting surface using cleaning compound.
  - 2 Remove paper backing from new label and position in place on mounting surface.
  - 3 Press label firmly to remove air bubbles from under label.
  - 4 Secure instruction plates to mounting surface using screws and washers retained from removal.

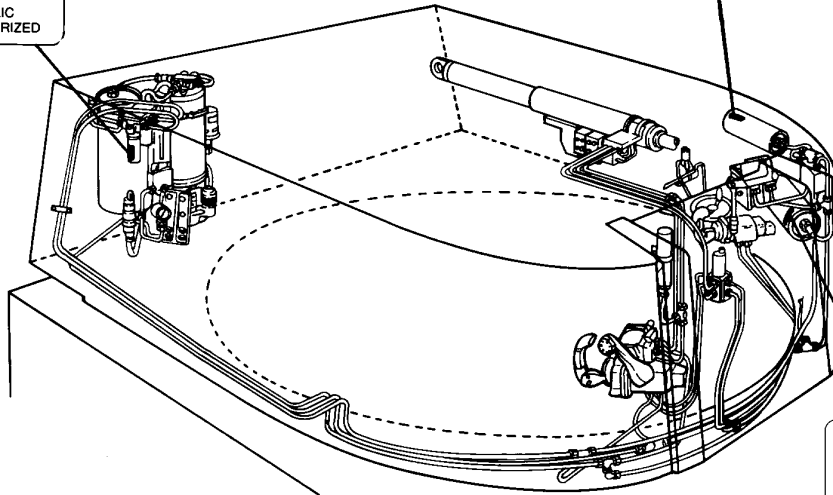
2-7 DECALS, LABELS, AND INSTRUCTION SIGNS — CONTINUED

**HYD OIL FILTER**  
**CAUTION**  
DO NOT LOOSEN FILTER  
CANISTER UNTIL HYDRAULIC  
SYSTEM HAS BEEN DEPRESSURIZED

**HYD OIL FILTER**  
**CAUTION**  
DO NOT LOOSEN FILTER  
CANISTER UNTIL HYDRAULIC  
SYSTEM HAS BEEN DEPRESSURIZED

**HYD OIL FILTER**  
**CAUTION**  
DO NOT LOOSEN FILTER  
CANISTER UNTIL HYDRAULIC  
SYSTEM HAS BEEN DEPRESSURIZED

**PISTON ACCUMULATOR**  
PART NO. 11665003 STOCK NO. \_\_\_\_\_  
MGF BY \_\_\_\_\_ SERIAL NO. \_\_\_\_\_  
**INSTRUCTIONS**  
1. RELEASE FLUID PRESSURE BEFORE DISCONNECTING  
PRESSURE LINE. RELEASE AIR AND FLUID PRESSURE  
BEFORE DISASSEMBLING, STORING OR SHIPPING ACCUMULATOR  
2. USE DRIED NITROGEN IN GAS PORT  
CAUTION - DO NOT USE OXYGEN OR HYDROGEN  
3. 3000 PSI MAXIMUM OPERATING PRESSURE  
4. OIL VOLUME 60 CUBIC INCHES



**CAUTION**  
CLOSE BUSTLE DOORS  
BEFORE TRAVERSING  
CAB

DIRECT FIRE RANGE PLATE 155MM HOWITZER			
M549A1 RAP		M107 HE PROJECTILE	
ROCKET OFF		M119A1 PC WB	
M203 SERIES PC RB		M119A2 PC RB	
RANGE	ELEV	RANGE	ELEV
METERS	MILS	METERS	MILS
400	3	400	4
600	5	600	7
800	6	800	9
1000	8	1000	11
1200	9	1200	14
1400	11	1400	16
L15 HE PROJECTILE M107 HE PROJECTILE		M203 SERIES PC RE M4A2 PC WB	
RANGE	ELEV	RANGE	ELEV
METERS	MILS	METERS	MILS
400	6	400	6
600	10	600	10
800	13	800	13
1000	16	1000	16
1200	20	1200	20
1400	23	1400	23

DIRECT FIRE RANGE PLATE 155MM HOWITZER			
M107 HE PROJECTILE M119A1 PC (WB)		M107 HE PROJECTILE M4A2 PC (WB)	
RANGE	ELEV	RANGE	ELEV
(METERS)	(MILS)	(METERS)	(MILS)
400	4	400	6
600	7	600	10
800	9	800	13
1000	11	1000	16
1200	14	1200	20
1400	16	1400	24

PLATE DIRECT FIRE P/N 11785314

**CAUTION**  
COVER MUST BE CLOSED  
WHEN NOT IN USE

DIRECT FIRE MOVING TARGET LEAD			
TARGET SPEED (MPH)	TARGET DIRECTION OF TRAVEL LEAD IN MILS (m)		
	←	×	↓
5	5 m	5 m	0 m
10	10 m	5 m	0 m
15	15 m	10 m	0 m
20	20 m	15 m	0 m
25	20 m	15 m	0 m
30	30 m	20 m	0 m

**CAUTION**  
ALWAYS PLACE RAMMER IN STOWED  
POSITION WHEN ELEVATING CANNON  
MORE THAN 500 MILS

**WARNING**  
ENSURE CUPOLA COVER LATCH  
ASSY IS FULLY ENGAGED

OUTLET ← INLET  
INLET → OUTLET  
ROTATION

HYDRAULIC MOTOR  
ORD NO. 10923498  
MFR SER NO.

MAX RPM	4800
MAX PSI	3000
CU IN/REV	803

FILL CASE WITH OIL BEFORE STARTING

**CAUTION**  
HIGH INTENSITY NOISE  
HEARING PROTECTION  
REQUIRED

M825A1, NEAR ↑ LOCK PIN HOLE  
M83A1, M107+SPACER, FAR HOLE  
THIS SIDE OUT FOR ALL PROJECTILES  
↑ M864, THIS LOCKING PIN HOLE  
M549A1 ↑ M795 FAR HOLE NEAR HOLE

M549A1 ↑ M795 FAR HOLE NEAR HOLE  
↑ M864, THIS LOCKING PIN HOLE  
M825A1, NEAR ↑ LOCK PIN HOLE  
M83A1, M107 + SPACER, FAR HOLE

---

## Section III. PREVENTIVE MAINTENANCE CHECKS AND SERVICES (PMCS), LUBRICATION INSTRUCTIONS, AND MANDATORY REPLACEMENT PARTS

---

### 2-8 LUBRICATION

---

#### 2-8.1 General

All lubrication procedures applicable to the unit maintenance level have been integrated within the PMCS procedures found in Table 2-2, Preventive Maintenance Checks and Services for M109 Self-Propelled Howitzer. Information on authorized lubricants, lubrication intervals, man-hour requirements, the Army Oil Analysis Program, and other areas pertinent to lubrication may be found in the remainder of para 2-8.

#### 2-8.2 Lubrication Intervals

Lubrication procedures are integrated within the PMCS procedures in accordance with the interval in which performance is required. For example, a lubrication required annually is incorporated with the annual preventive maintenance procedures. The "Interval" column of the PMCS table indicates the appropriate interval for performing lubrication.

Oil and filters are to be changed whenever they are known to be contaminated or clogged.

When AOAP analysis service is available, change oil and filters at the direction of the AOAP laboratory.

When AOAP analysis service is not available, change oil and filters at 75 hours or 750 miles of operation.

Always lubricate after water fording.

Use Table 2-1, Expected Temperature Lubrication Table, to determine seasonal lubrication requirements. When changing engine and transmission oil due to seasonal requirements always change the oil filters.

The following lubrication interval symbols shall be used on illustrations, as applicable.

Q – quarterly

A – annually

AOAP – Upon direction of Army Oil Analysis Program

RDS – Rounds fired

#### 2-8.3 Cleaning

**WARNING**

Solvents can burn easily, can give off harmful vapors, and are harmful to skin and clothing. To avoid injury or death, keep away from open fire and use in well-ventilated area. If solvent gets on skin or clothing, wash immediately with soap and water.

■ Clean parts with cleaning compound (item 9.1, Appx D).

**2-8.4 Lubricants and Military Symbols**

Lubricants are identified by standard military symbols in accordance with MIL-HDBK-113, MIL-HDBK-275, or MIL-HDBK-267, as applicable. Lubricants, along with their military symbols, required for unit maintenance are identified below.

GAA	Grease, Automotive and Artillery (MIL-G-10924)
GMD	Grease, Molybdenum Disulfide for Low and High Temperatures (MIL-G-21164)
OHT	Hydraulic Fluid, Petroleum Base, Preservative, Hydraulic Equipment (MIL-H-6083)

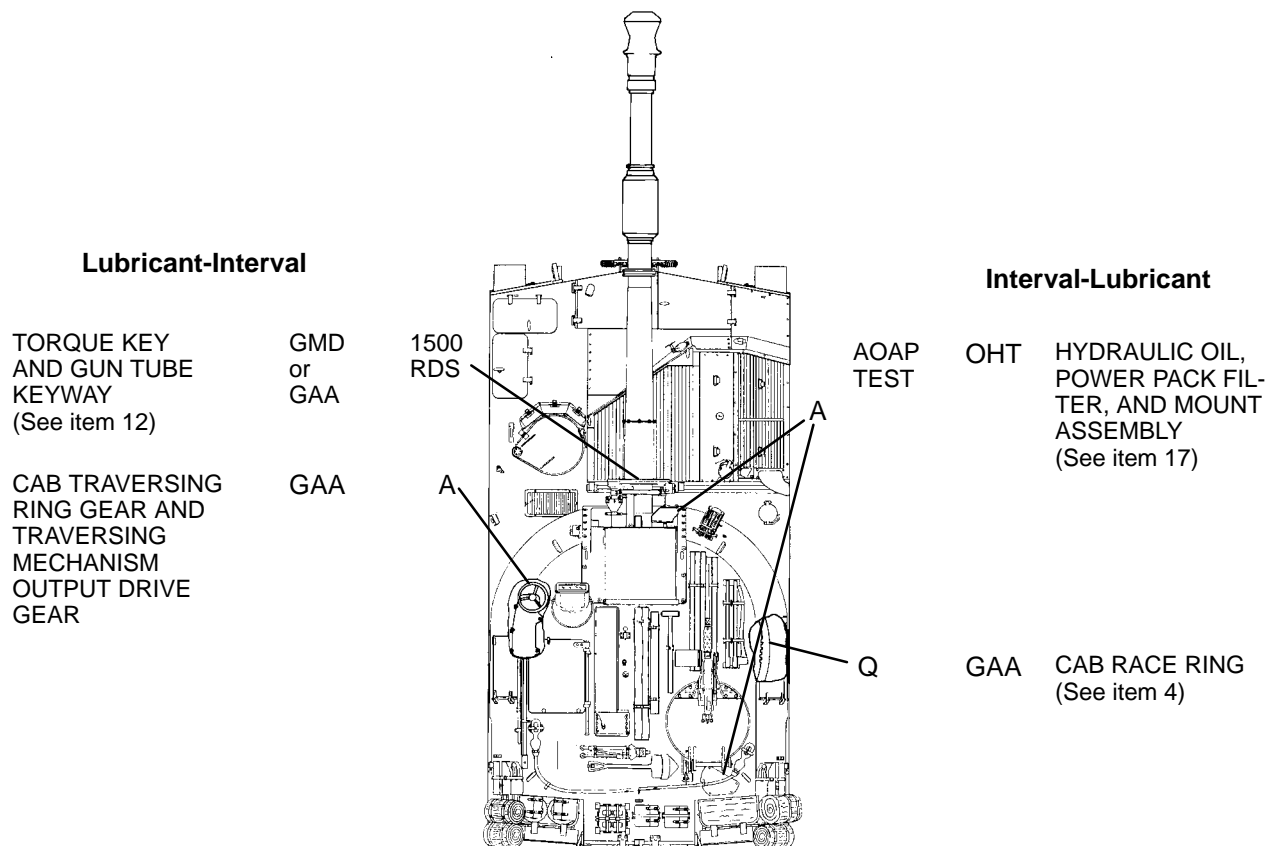
**2-8.5 Leakage Definitions.**

Leakage definitions for PMCS shall be classified as follows:

- a. Class I. Seepage of fluid (as indicated by wetness or discoloration) not great enough to form drops.
- b. Class II. Leakage of fluid great enough to form drops but not enough to cause drops to drip from item being checked/inspected.
- c. Class III. Leakage of fluid great enough to form drops that fall from the item being checked/inspected.

**2-8.6 Lubrication Points**

Points that must be lubricated by unit maintenance, their required lubrication intervals, and the required lubricants are illustrated below. The amount of lubricant required is given in the "Capacity" column of Table 2-1.





**Table 2-1. LUBRICATION TABLE**

TOTAL MAN-HR	
Quarterly	0.5
Annually	1.0

LUBRICANTS	COMPONENTS	REFILL CAPACITY (APPROX)	EXPECTED TEMPERATURES			INTERVAL
			ABOVE +15°F ABOVE -90°C	+40°F TO -15°F (+4°C TO -26°C)	+40°F TO -65°F (+4°C TO -54°C)	
GMD (MIL-G-21164)	Torque Key and Gun Tube Keyway	As req	GMD	GMD	GMD	A or 1500 RDS
GREASE, MOLYBDENUM DISULFIDE FOR LOW AND HIGH TEMPERATURES						
GAA (MIL-L-10924)	Cab race ring	As req	GAA	GAA	GAA	Q
GREASE, AUTOMOTIVE AND ARTILLERY	Traversing Mechanism Ring Gear and Output Drive Gear	As req	GAA	GAA	GAA	A
OHT (MIL-H-6083)	Hydraulic Oil					
HYDRAULIC FLUID, PETROLEUM BASE, PRESERVATIVE, HYDRAULIC EQUIPMENT	Power Pack-Filter and Mount Assembly	48 Qts (45.42 l)	OHT	OHT	OHT	AOAP

NOTE: For Artic Operation refer to FM 9-207.

---

## 2-9 PREVENTIVE MAINTENANCE CHECKS AND SERVICES (PMCS)

---

### 2-9.1 General

Preventive maintenance is the step-by-step caring, inspecting, and servicing of equipment to maintain it in good condition and to locate problems before extensive and time-consuming repairs or replacements are needed. Refer to DA PAM 750-8 for instructions on use of forms for preventive maintenance services.

This section has the procedures and instructions needed to perform unit preventive maintenance checks and services. These services are done by unit maintenance personnel with the help of the vehicle crew.

### 2-9.2 Explanation of Preventive Maintenance Checks and Services, Table 2-1, Columns

- a. The "Item No." column provides the number to be used by the mechanic when recording all faults found and actions taken on DA Form 2404, Equipment Inspection and Maintenance Worksheet. The item number on the DA Form 2404 must correspond to the item number of the preventive maintenance check.
- b. The "Interval" column provides the interval at which preventive maintenance checks and services are to be performed by unit maintenance. The intervals are determined by whichever comes first: quarterly; annually; or 750 miles or 75 hours. This is scheduled on DD Form 314 in accordance with DA PAM 750-8.

After operation in water, mud, and loose sand, the vehicle should be cleaned and lubricated as soon as possible, without waiting for the next scheduled service.

- c. The "Item to Check/Service" column identifies specific items to be checked or serviced.
- d. The "Procedure" column tells how to do required checks and services. Carefully follow these instructions.

TM 9-2350-311-10 contains maintenance instructions which the unit mechanic must use to perform the specified duties.

Unit maintenance is defined by, and limited to the following general procedures. Approval to perform higher category services must be given by the supporting maintenance unit.

- 1 ADJUST. Make all needed adjustments using instructions in this manual and/or technical bulletins.
  - 2 CLEAN. Clean the unit to remove old lubricant, dirt, and other foreign matter. Special cleaning instructions are given as needed.
  - 3 LUBRICATION. Lubrication applies to lubrication operations which should be done at the prescribed time intervals or usage.
  - 4 TIGHTEN. All tightening operations should be done according to specified torque readings where noted in this manual. When torque is not specified, care should be taken not to strip or distort threads by overtightening. Use a torque-indicating wrench where specified. Tightening includes the correct installation of lock-washer, nut, lockwire, or cotter pin needed to secure the tightened nut or bolt in place.
  - 5 REPAIR. Restore an item to a serviceable condition. This includes, but is not limited to inspection, cleaning, preserving, adjusting, replacing, welding, riveting, and strengthening. Refer to Appendix B for authorized crew and unit maintenance level repair, replace, and adjusting functions.
- e. The "Not Fully Mission Capable if" column explains when and why the equipment cannot be used.

## 2-9 PREVENTIVE MAINTENANCE CHECKS AND SERVICES (PMCS) — CONTINUED

### 2-9.3 Vehicle Cleanliness

**CAUTION**

Do not direct a stream of water or steam against the opening between the hull and turret (turret ring), grilles, exhaust deflectors, fire control, or armament openings. Damage to components could result.

The crew should bring a clean vehicle to a scheduled PMCS. It should be dry and not caked with mud. Washing the vehicle should not be done just before an inspection. Some defects, such as loose parts and oil leaks, may not be noticed immediately after washing.

### 2-9.4 General Checks

- a. Electrical Connector/Wires. Check connectors; if loose, tighten. Check for open insulation cracks on wires. Repair with electrical tape (item 39, Appx D) or replace. Complete cab wiring diagram, harnesses, and connectors are described in detail in Chapter 8 of this manual.

**WARNING**

Never tighten hydraulic lines or fittings when hydraulic system is pressurized. Damage to tubes and fittings could result in injury to personnel.

- b. Hydraulic Connector/Lines and Hoses. Check connectors; if loose or if stained by hydraulic fluid, tighten. Check lines and hoses for cracks, loose clamps, or stains from hydraulic fluid. Repair or replace lines and tubes that are damaged.
- c. Seals. Check for leaks (fluid stains). Check condition of gasket material. Replace if deteriorated. Check door/hatch seals for deteriorations, cracks, and tears.
- d. Loose Bolts. Although a loose bolt can be difficult to spot without actually applying a wrench, you can often tell by loose or chipped paint around the bolt head and bare metal or rust present at the base of the bolt head.
- e. Welds. Many items are attached to the cab with welds. Damaged welds may be detected by rust or chipped paint where cracks occur.

**INITIAL SETUP**

Tools

Artillery and turret mechanic's tool kit  
(CL 5180-95-A12, see SC 9999-01-SKO)  
(Q, A, 1500 RDS)

Lockwashers (8 or 10) (item 88, Appx G) (A, 1500 RDS)  
Lockwire (item 32, Appx G) (Q, A)  
Lockwire (item 33, Appx G) (Q)  
Lubrication fittings (item 14, Appx D) (Q)



Materials/Parts

GAA (item 18, Appx D) (Q, A)  
GMD (item 20, Appx D) (A, 1500 RDS)  
Hydraulic fluid, OHT (item 1, Appx D) (A, AOAP)

References

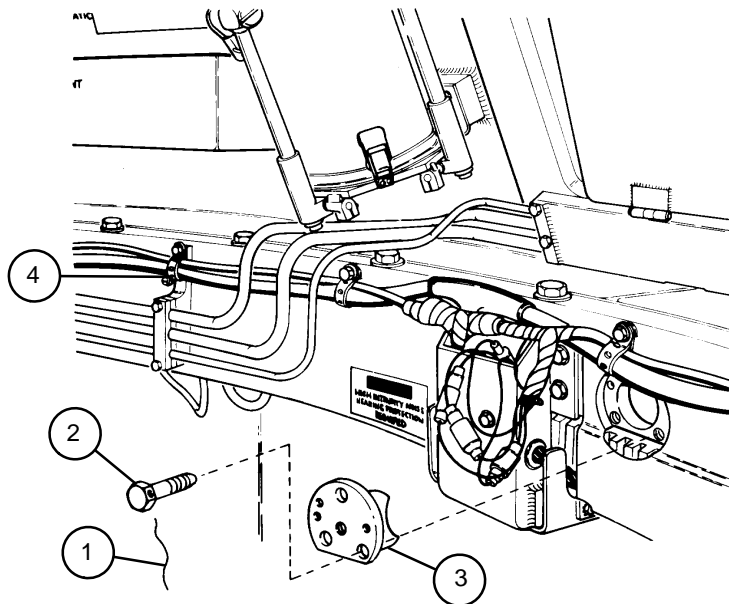
DA PAM 750-8 (AOAP)  
TM 3-6680-316-10 (A)  
TM 750-116 (Q)  
TM 9-2350-311-10 (Q, A, 1500 RDS)

**Table 2-2. PREVENTIVE MAINTENANCE CHECKS AND SERVICES FOR M109 SELF-PROPELLED HOWITZER**

Item No.	Interval	Location	Procedure	Not Fully Mission Capable if:
		Item to Check/Service		
1 2	Quarterly Quarterly	Mount M145/M145A1 a. M117/M117A2 Telescope	Check synchronization (para 18-4). Purge quarterly (TM 750-116). Purge immediately if moisture is found in units before quarterly service date.	
<b>WARNING</b>				
 <p>The M1A1 collimator is radioactively illuminated. Check for presence of illumination and damage. If discovered broken, damaged, or defective, follow the procedures listed on page b.</p>				
		b. M1A1 Collimator c. M118A2/M118A3 Elbow Telescope d. M15 Elevation Quadrant		
<b>WARNING</b>				
 <p>The M140 alinement device is radioactively illuminated. Check for loss of luminescence, breakage, damage, or defects. If present, follow the procedures on page b.</p>				
3	Quarterly	e. M140 Alinement Device f. M42 Tank Periscope  Fire Control Instruments	<div style="text-align: center;"><b>WARNING</b></div> <p>Failure to aline reticle of M140 alinement device with reticles of M117/M117A2 panoramic telescope and M118A2/M118A3 elbow telescope using boresighting procedure could result in projectiles landing outside target area. Injury or death of friendly forces can result from firing with misaligned fire control equipment.</p> <p>Perform boresighting on target board, alining reticles of M117/M117A2 panoramic telescope and M118A2/M118A3 elbow telescope on test target board. Next, install the M140 alinement device in front of each sighting and fire control instrument (M117/M117A2 panoramic telescope and M118A2/M118A3 elbow telescope) to ensure that reticle of the M140 alinement device coincides with the reticles of the M117/M117A2 panoramic telescope. This check must be performed to ensure accuracy of the M140 alinement device (TM 9-2350-311-10).</p>	

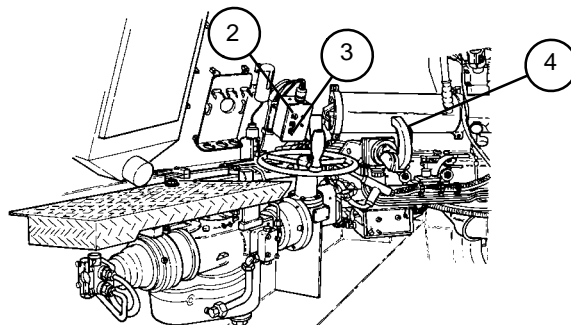
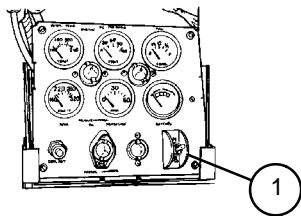
**Table 2-2. PREVENTIVE MAINTENANCE CHECKS AND SERVICES FOR M109 SELF-PROPELLED HOWITZER – CONTINUED**

Item No.	Interval	Location	Procedure	Not Fully Mission Capable if:
		Item to Check/Service		
4	Quarterly	Cab Race Ring	<p>Check the cab bearing/race ring assembly as follows:</p> <ol style="list-style-type: none"> <li>a. Remove lockwire (1), three cap screws (2), and cover (3). Discard lockwire.</li> <li>b. Manually traverse cab and look through access hole to see that race has enough lubrication. If race surfaces, helical compression springs, race ring spacers, and bearing balls are lightly coated with grease, you are okay. Reinstall ball turret cover.</li> <li>c. If lubrication is needed, remove one if the three plugs (4) around inner race. Install lubrication fittings and apply GAA lightly through lubrication fittings while manually traversing cab through two complete 6400 mil cycles to coat bearing ball surface of race. Do not over lubricate. Remove lubrication fitting, reinstall plugs (4), ball turret cover (3), cap screws (2), and new lockwire (1).</li> </ol>	



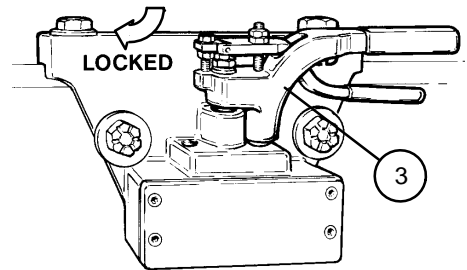
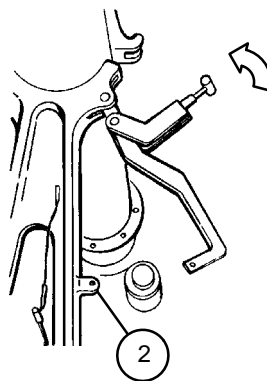
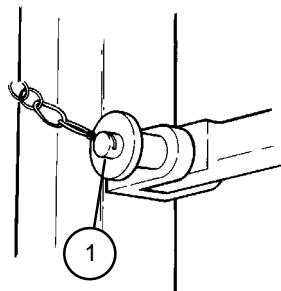
**Table 2-2. PREVENTIVE MAINTENANCE CHECKS AND SERVICES FOR M109 SELF-PROPELLED HOWITZER – CONTINUED**

Item No.	Interval	Location	Procedure	Not Fully Mission Capable if:
		Item to Check/Service		
5	Quarterly	Elevation Mechanism	<p>a. Position vehicle on level ground.</p> <p>b. Release travel lock and stow.</p> <p>c. Elevate cannon through entire range of -53 to +1333 mils:</p> <ol style="list-style-type: none"> <li>1. Manual                             <ol style="list-style-type: none"> <li>(a) From AG side of turret, manually elevate and depress howitzer.</li> <li>(b) Check for leaks in hydraulic lines, valves, and controls. Also for smoothness. Repair as necessary.</li> </ol> </li> <li>2. Power                             <ol style="list-style-type: none"> <li>(a) Turn MASTER switch (1) and CAB POWER switch (2) to ON (light lit).</li> <li>(b) Turn ELEVATION CONTROL switch (3) to GUNNER position.                                     <ol style="list-style-type: none"> <li>(1) Elevate and depress cannon through entire range using gunner's control handle (4).</li> <li>(2) Check for smoothness of operation through entire range.</li> <li>(3) Check for leaks in hydraulic lines, valves, and controls. Repair as necessary.</li> </ol> </li> <li>(c) Turn ELEVATION CONTROL switch (3) to NO. 1 position. Perform steps 2(a) through 2(c) again.</li> </ol> </li> </ol>	Elevating fails after attempting both methods.



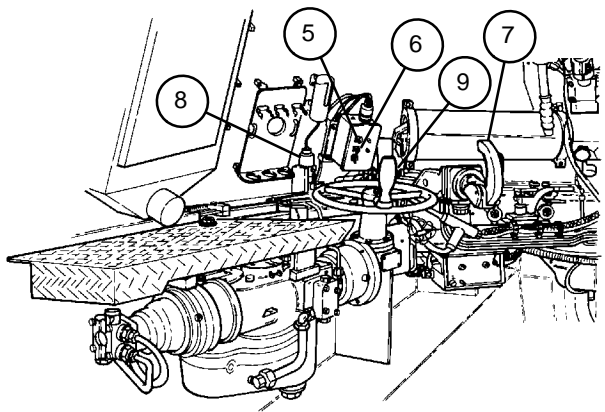
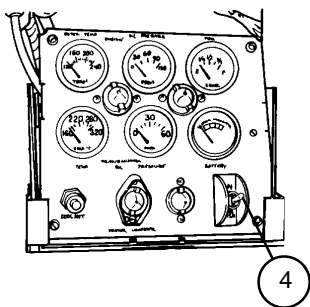
**Table 2-2. PREVENTIVE MAINTENANCE CHECKS AND SERVICES FOR M109 SELF-PROPELLED HOWITZER – CONTINUED**

Item No.	Interval	Location		Procedure	Not Fully Mission Capable if:
		Item to Check/Service			
6	Quarterly	Breech Operating Cam		Check and adjust (para 5-12).	
7	Quarterly	Buffer Counter Recoil Assembly		Prior to returning cannon tube to battery, perform buffer inspection (para 5-17).	
8	Quarterly	Breech Assembly		a. Breechblock: Check for cracks, ruined/damaged locking threads and ease/smoothness of operation. b. Firing Block Assembly: Check for rust deterioration of firing pin, and condition of firing block. c. Obturator: Check for correct alinement of front and rear split ring, corrosion/deterioration/pitting of rings/assembly.	
9	Annually	Contact Arm Assembly and Cab Electrical Cable and Brushes		Clean and adjust (para 9-3).	
10	Annually	Main Accumulator		Perform zero pressure check (para 6-10).	
11	Annually	Cab Traversing Mechanism		Perform cab traverse check as follows: (Chapter 11): a. Position vehicle on level ground. b. Press button (1) to release pin. c. Release cannon travel lock (2) and cab traverse lock (3).	



**Table 2-2. PREVENTIVE MAINTENANCE CHECKS AND SERVICES FOR M109 SELF-PROPELLED HOWITZER – CONTINUED**

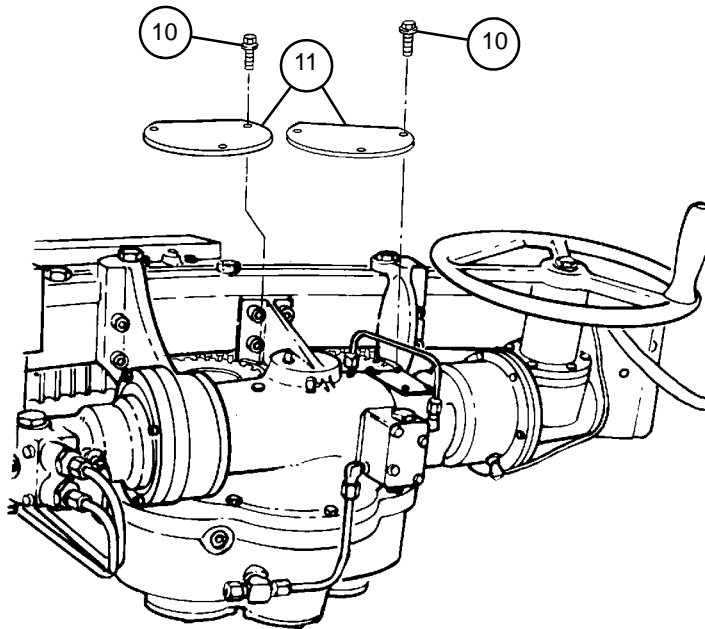
Item No.	Interval	Location	Procedure	Not Fully Mission Capable if:
		Item to Check/Service		
11	Annually	Cab Traversing Mechanism – Continued	<p>d. Traverse cab by power and manual controls through entire range of 6400 mils:</p> <ol style="list-style-type: none"> <li>1. Power                             <ol style="list-style-type: none"> <li>(a) Turn MASTER switch (4) and CAB POWER switch (5) to ON (light lit).</li> <li>(b) Turn TRAVERSE CONTROL switch (6) to POWER position (red light lit).</li> <li>(c) Turn gunner control handle (7) left for left traverse and right for right traverse.</li> <li>(d) Pull up on override lever on clutch valve (8) in M109A4/ M109A5 howitzers to activate solenoid override in the event of an electrical failure.</li> <li>(e) Check for leaks in hydraulic lines, valves, and controls. Repair as necessary.</li> </ol> </li> <li>2. Manual                             <ol style="list-style-type: none"> <li>(a) Turn TRAVERSE CONTROL switch (6) to MANUAL position to traverse cab.</li> <li>(b) Turn traverse handwheel (9) to traverse cab.</li> </ol> </li> </ol>	



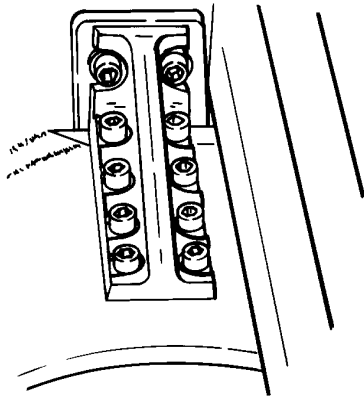
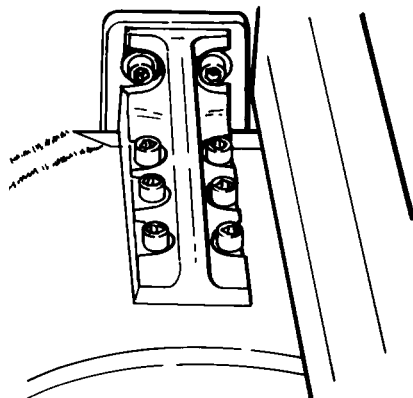


**Table 2-2. PREVENTIVE MAINTENANCE CHECKS AND SERVICES FOR M109 SELF-PROPELLED HOWITZER – CONTINUED**

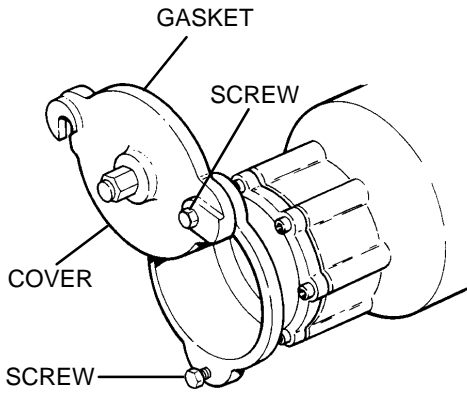
Item No.	Interval	Location	Procedure	Not Fully Mission Capable if:
		Item to Check/Service		
11	Annually	Cab Traversing Mechanism – Continued	<div style="border: 1px solid black; padding: 2px; display: inline-block; margin-bottom: 10px;"><b>CAUTION</b></div> <p>Don't overlube. Too much lubricant will drip out onto slip rings segments and holders covering electrical failure.</p> <p>e. Remove six bolts (10) and two access covers (11). If lubricant is contaminated (black and gritty), clean and coat sparingly with GAA. Reinstall plates and screws.</p>	



**Table 2-2. PREVENTIVE MAINTENANCE CHECKS AND SERVICES FOR M109 SELF-PROPELLED HOWITZER – CONTINUED**

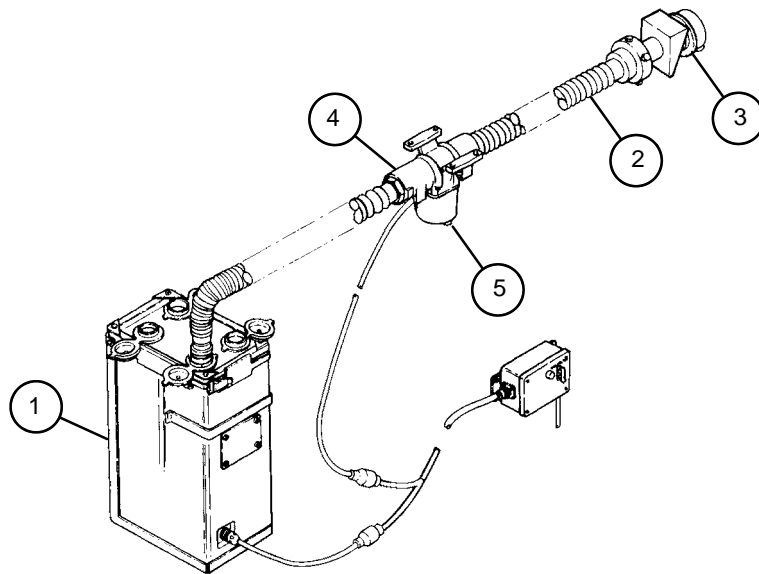
Item No.	Interval	Location	Procedure	Not Fully Mission Capable if:
		Item to Check/Service		
12	Annually or 1500 Rounds	Torque Key	<p><b>NOTE</b></p> <ul style="list-style-type: none"> <li>Do not mix grease. If changing between GMD and GAA wipe key and keyway. Clean before using new grease.</li> <li>M185 cannon assembly has one torque key keyway. M284 cannon assembly has two keyways for redesigned torque key.</li> </ul> <p>Remove, measure, and lubricate torque key (located at top of cannon tube in front of exterior mount) (para 5-10). Measure torque key in at least three places. If measurement across torque key is less than 31/32 inch (24.6 mm) for M178 mount or 1-9/16 inches (3.97 cm) for M182 mount, replace torque key. Grease that part of torque key which fits in keyway with GMD or GAA and reinstall.</p>	
		 <p>M178 MOUNT CONFIGURATION</p>	 <p>M182 MOUNT CONFIGURATION</p>	

**Table 2-2. PREVENTIVE MAINTENANCE CHECKS AND SERVICES FOR M109 SELF-PROPELLED HOWITZER – CONTINUED**

Item No.	Interval	Location	Procedure	Not Fully Mission Capable if:
		Item to Check/Service		
13	Annually	Recuperator Cover Gasket and High Pressure Nitrogen Check	<p><b>NOTE</b></p> <p>Loosen cap screws to stop before rotating cover to open position.</p> <ol style="list-style-type: none"> <li>Inspect gasket for serviceability.</li> <li>Replace if unserviceable (para 19-2).</li> </ol>  <ol style="list-style-type: none"> <li>Verify high pressure nitrogen <math>700 \pm 25</math> psi (<math>4827 \pm 172</math> kPa) (para 19-2).</li> </ol>	
14	Annually	Scribe Lines on M15 Quadrant	Verify correctness of scribe lines (TM 9-2350-311-10).	
15	Annually	NBC Equipment (M109A4/M109A5 Howitzers Only)	<div style="border: 1px solid black; padding: 5px; text-align: center; width: fit-content; margin: 0 auto;"><b>WARNING</b></div> <p>After suspected NBC exposure of vehicle, all air filter elements in M2A2 air purifier shall be handled by personnel wearing NBC protective equipment. Death or bodily injury can result from not wearing NBC protective equipment.</p> <p><b>NOTE</b></p> <p>For general guidance on replacement of filters, refer to para 17-3:</p>	

**Table 2-2. PREVENTIVE MAINTENANCE CHECKS AND SERVICES FOR M109 SELF-PROPELLED HOWITZER - CONTINUED**

Item No.	Interval	Location	Procedure	Not Fully Mission Capable if:
		Item to Check/Service		
15	Annually	NBC Equipment (M109A4/M109A5 Howitzers Only) - Continued	<p>a. Inspect M2A2 air purifier (1) for dents, loose connections, and missing parts. Notify support maintenance if any damage is detected.</p> <p>b. Perform airflow check at each station using M39 airflow tester (TM 3-6680-316-10).</p> <p>c. Inspect condition of hose assemblies (2). Check for deterioration, loose connections, holes, tears, and other damage (para 17-5). Check that air moves through all orifice connectors (3) when system is on.</p> <p style="text-align: center;"><b>NOTE</b></p> <p>Allow M3 electrical air heater to operate for approximately 15 minutes before checking for warm air.</p> <p>d. Check operation of M3 electrical air heater (4) by turning control knob (5) on. NBC indicator should light and air should get warmer as control knob is turned clockwise.</p> <p>e. Troubleshoot NBC system if defective (para 3-3j.).</p>	



**Table 2-2. PREVENTIVE MAINTENANCE CHECKS AND SERVICES FOR M109 SELF-PROPELLED HOWITZER - CONTINUED**

Item No.	Interval	Location	Procedure	Not Fully Mission Capable if:
		Item to Check/Service		
16	Annually	Decals, Instruction Plates, Stencil Markings, and Paint	a. Refer to para 1-14.5 for stencil locations. b. Replace decals and instruction plates (para 2-7). c. Stencil markings which are not legible.  <p style="text-align: center;"><b>NOTE</b></p> Refer to Army Oil Analysis Program DA PAM 750-8.  Replace when oil analysis program at Army installation indicates contaminated hydraulic fluid (OHT). If hydraulic fluid is contaminated, notify support maintenance.	Contaminated Hydraulic Fluid
17	Annually	Hydraulic Oil, Power Pack Filter, and Mount Assembly		

**Table 2-3. PMCS MANDATORY REPLACEMENT PARTS LIST**

ITEM NO.	PART NO.	NSN	NOMENCLATURE	QTY
1	MS20995C41	9505-00-331-3275	Lockwire	V
2	MS20995F41	9505-00-684-4843	Lockwire	V

---

## Section IV. GENERAL MAINTENANCE PROCEDURES

---

### 2-10 DISASSEMBLY AND ASSEMBLY PROCEDURES

---

A detailed removal-installation and disassembly-assembly is provided for all assemblies requiring replacement and repair. Numbered item callouts reflect removal or disassembly sequences. Always follow the specific instructions provided in connection with each maintenance procedure in Chapters 4 through 19.

#### NOTE

- When troubleshooting or when working on a wiring harness or hydraulic assembly, remember to tag wires, circuits, terminals, and hydraulic lines and fittings to make assembly easier.
- In marking shims or other parts, use dye, indelible ink, or paint. Chalk or crayon can erase easily and should not be used.

As a general rule, disassembly procedures instruct the mechanic to begin by removing only as many major components and subassemblies as required for maintenance. When practical, temporarily reinstall screws, bolts, washers, and nuts to prevent loss. Mechanics can also use a plastic storage container or plastic bags (item 4, Appx D) to sort and label parts.

In Chapters 4 through 19, assembly procedures are provided for all components requiring maintenance at the unit level. During assembly and installation, remember to replace items discarded during removal and disassembly. Mandatory replacement parts include all preformed packings, non-metallic gaskets and seals, cotter pins, lockwire, and lockwashers. These are listed in Appendix G, Mandatory Replacement Parts List.

Some tasks calling for installation of hydraulic fittings, ports in sighting equipment, gaskets, seals, and mating surfaces on doors will instruct the mechanic to apply a specific adhesive or sealant. These adhesives and sealants are listed in Appendix D, Expendable and Durable Items List.

Special care is required in handling and installing preformed packings. Damaged preformed packings can result in equipment failure. When installing preformed packings, apply a light film of hydraulic fluid (item 21, Appx D) to make insertion easier. Avoid cutting or nicking preformed packings.

When installing any hydraulic fitting, tighten the fitting to align with the connecting lines. Repositioning can loosen fittings, cause leaks, and damage preformed packings.

---

### 2-11 REPLACEMENT OF PARTS

---

#### 2-11.1 Replacement

As a general rule, discard any part which is damaged too much to perform its function.

Mandatory replacement parts are listed in Appendix G, Mandatory Replacement Parts List.

---

## 2-11 REPLACEMENT OF PARTS — CONTINUED

---

### 2-11.2 Inspection

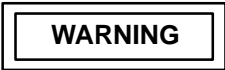
Inspect the following:

<u>Item</u>	<u>Discard if:</u>
Springs	Broken, kinked or cracked
Screws, bolts, nuts	Threads are stripped or cracked

### 2-11.3 Cleaning

Use a tap or die to clean rust, accumulated dirt, sealant, and paint from bolts, screws, nuts, and threaded holes.

### 2-11.4 Tools



Special care should be exerted when using a sling and hoist to avoid injury to personnel. Take the weight of the assembly to be moved into account.

- a. In replacing parts on the howitzer, select the tool appropriate to the part. For example, use a wrench and not pliers to tighten a hex head bolt. Pliers will serrate or dog-ear the bolt making later removal difficult.
- b. Some maintenance tasks require special or fabricated tools. The initial setup of a task will name any special or fabricated tools needed for that procedure. Use these special tools only for the maintenance tasks for which they are designed or called out. Personnel should be carefully instructed in the use of these tools.

---

## 2-12 CLEANING

---

### a. General Guidelines

Clean the howitzer and its parts to remove old lubricant, dirt, rust, paint, accumulated sealant, and adhesives. Satisfactory maintenance and operation of the howitzer will be impaired if foreign substances are not removed from its assemblies.

To ensure safety and to prevent damage to equipment, follow these guidelines when cleaning howitzer components:



- Mineral spirits and paint thinner are toxic and highly flammable. Never use them in cleaning.
- Solvents can burn easily, can give off harmful vapors, and are harmful to skin and clothing. To avoid injury or death, keep away from open fire and use in well-ventilated area. If solvent gets on skin or clothing, wash immediately with soap and water.

<b>CAUTION</b>
----------------

Do not direct stream of water or steam under pressure against the opening between the hull and turret (race ring), grilles, exhaust deflectors, fire control, or armament openings. Damage to components could result.

- 1 Clean parts after disassembly.
- 2 After cleaning hydraulic components, coat bearings, pistons, and other parts having sliding fits or close running surfaces with hydraulic fluid (item 21, Appx D).
- 3 Clean parts immediately before assembly or installation.
- 4 Choose a cleaning agent appropriate to your task. Use soapy water or cleaning compound as appropriate. These cleaning agents are listed in Appendix D. Make sure area in which cleaning agents are used is well-ventilated. When cleaning fire control instruments, refer to TM 9–254 for expendable/durable items.
- 5 Wipe parts dry with a lint-free rag (item 25, Appx D).
- 6 After cleaning, protect all parts from dust and dirt.
- 7 When removing rubber gaskets and seals, clean the gasket seat or seal seat to remove dirt and old adhesive.
- 8 Nameplates, caution plates, and instruction plates found in a dirty or corroded condition should be cleaned thoroughly and coated with a heavy coat of lacquer.

b. Cleaning Hydraulic Components

<b>WARNING</b>
----------------

- Compressed air is not to exceed 30 psi (207 kPa). Wear safety glasses when drying parts with compressed air. Failure to do so could cause serious injury to eyes and possible blindness. If you hurt your eyes or if a foreign object is blown into your eyes, seek medical attention immediately.
  - Solvents can burn easily, can give off harmful vapors, and are harmful to skin and clothing. To avoid injury or death, keep away from open fire and use in well-ventilated area. If solvent gets on skin or clothing, wash immediately with soap and water.
- 1 Wash hydraulic components, with the exception of sealed-type ball bearings, in cleaning compound (item 9.1, Appx D). Dry hydraulic parts, except for base and roller bearings, with dry, compressed air.
  - 2 After cleaning hydraulic components, coat bearings, pistons, and other parts having sliding fits or close running surfaces with hydraulic fluid (item 21, Appx D).
  - 3 When installing screws or valves, the assembler's hands should be covered with a film of clean hydraulic fluid (item 21, Appx D).



---

## 2–12 CLEANING — CONTINUED

---

### c. Cleaning Seals, Electrical Components, and Flexible Hose

**CAUTION**

Do not clean seals, cables, and flexible hose with solvent. Solvent causes leather, rubber, and synthetic materials to dry rot and lose pliability, making them unserviceable.

- 1 Clean seals, cables, electrical insulation, wires, wiring harnesses, and flexible hose with soap (item 9, Appx D) and water. Immediately wipe dry with a clean cloth (item 25, Appx D).
- 2 Clean electrical contact points with crocus cloth (item 11, Appx D). Remove dust from contact points thoroughly after cleaning.

---

## 2–13 INSPECTION

---

### a. Introduction

The MAC in Appendix B of this manual assigns certain items for inspection at the unit level. The purpose of inspection is to find out whether a howitzer component is serviceable. During inspection the mechanic tries to pinpoint conditions which could cause equipment failure, such as bearings without enough lubrication, worn or brittle insulation, missing seals, or broken leveling vials. When the mechanic determines that a component is not serviceable, he repairs or replaces the component if that function is assigned to unit maintenance. If the item is not assigned for unit repair or replacement, the mechanic notifies support maintenance.

### b. General Procedures

Equipment defects can be spotted at the crew level by performing the PMCS in TM 9–2350–311–10. Equipment defects can be discovered at the unit level by performing the PMCS outlined in Chapter 2 and the troubleshooting procedures in Chapter 3 of this manual. A solution is offered for every equipment malfunction pinpointed by troubleshooting at the unit level.

- 1 Before operating the howitzer, make a visual check of components mounted on the vehicle. These visual inspections determine the condition of the equipment. If components are found to be defective, the mechanic should take care that further damage to equipment is prevented.
- 2 When components are removed from the vehicle for repair, inspect disassembled parts for defects. Replace defective components of equipment assigned for repair at unit level. If malfunctioning components are not assigned for repair at unit level, notify support maintenance.
- 3 Specific inspection procedures called for in the MAC are outlined in maintenance chapters 4 through 19.
- 4 Some tests on systems and components can only be performed when elevating, traversing, and ramming systems are fully installed and operational. Certain tasks will direct the mechanic to elevate and traverse to check the operation of hydraulic and electrical components.

---

## 2-14 GENERAL REPAIR PRACTICES

---

### General Procedures

<b>CAUTION</b>
----------------

Do not spot paint rammer valve plunger or roller as it will impede proper operation.

- 1 Damaged or worn paint should be touched up. In painting the howitzer, follow procedures outlined in TM 43-0139, Painting Instructions for Army Materiel.
- 2 If a screw, bolt, nut, or other fastener is surrounded by chipped or damaged paint or by rust, check to see whether the fastener is loose. Tighten the fastener.
- 3 Do not paint electrical harnesses, wiring, hoses, or finished machine parts.
- 4 Refer to para 1-14.5 for location of stencil markings on vehicle.

### NOTE

When filing aluminum, clean file often with steel file brush.

- 5 Remove burrs, scratches, or raised metal. Use fine file (SC 5180-95-CL-A12), stone, or crocus cloth (item 11, Appx D) dipped in oil. Replace parts which have cracks or excessive burrs.
- 6 Code and tag electrical parts before removing.
- 7 Before testing circuits for continuity and for voltage across components, make sure connectors are tight and solder joints are securely joined.
- 8 See para 8-1 of this manual for replacement of typical electrical components such as male and female connectors, plugs, and receptacles.

---

## 2-15 WELDING

---

Refer to TM 9-237, Welding Theory and Application Operator's Manual, for welding instructions and welding materials.

---

## 2-16 SOLDERING

---

a. Introduction

**NOTE**

Use only rosin core solder and non-corrosive flux.

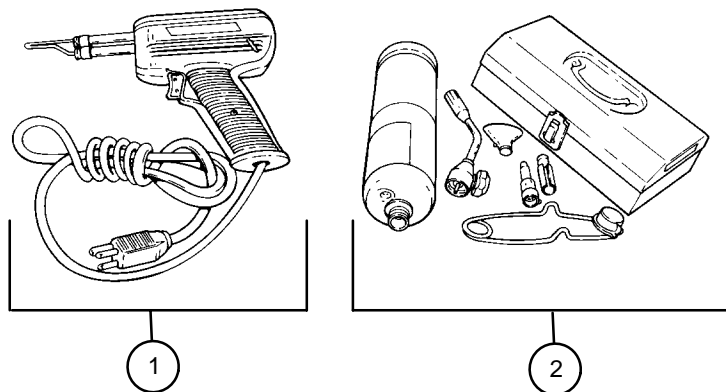
Rosin core solder, QQ-S-571, and flux, MIL-F-14256, are used in attaching some electrical leads to terminals and other components. More detailed information on solder can be found in TB SIG 222.

The soldering gun (1) and propane torch kit (2) used by unit maintenance is contained in the Number Two Common Tool Kit (SC 4910-95-CL-A72).

TB SIG 222 details complete procedures for soldering. This section outlines general soldering procedures, pinpoints practices which can lead to a bad soldering connection, and explains the difference between a good and a bad connection.

b. General Practices

- 1 Good solder connections are crucial. A great number of equipment malfunctions can be traced to poor soldering.
- 2 Keep the tip of your soldering gun clean. Wipe tip on a wet cloth, preferably a lint free rag (item 10, Appx D).
- 3 After cleaning the tip, "tin" the tip of the soldering gun to give the entire tip a wet look. Tinning protects the tip and helps in making good connections.
- 4 During soldering operations, if solder won't stick to the tip, or if solder begins to "ball," it is time to clean the tip. Wipe solder from tip with wet cloth. Then tin the tip again.
- 5 Tin wire leads before soldering them to other wires or components.



## c. Soldering a Connection

- 1 Apply flux (item 15, Appx D) to the component. Heat both the wire and the connection point with tip of soldering gun. If wire is insulated, do not melt the insulation.
- 2 Apply solder (item 34, Appx D) to heated wire/connection point. Let the heated wires and metal components melt the solder. Don't glob solder in general area of component and melt it with tip of gun.
- 3 Apply solder sparingly. You have enough solder when the tip and the connection are completely wet.
- 4 Allow the connection to harden before touching. When dry, the connection will be smooth and bright.

## d. Checking a Connection

- 1 If solder and connection look grainy, the connection is a poor one. Use gun to reheat connection if soldered joint does not look smooth and bright.
- 2 Check for a cold solder joint. If end of wire or component connection are mobile, a cold joint has been soldered. Reheat the connection and make sure both the lead and the component are heated sufficiently this time. If needed, apply a small amount of additional solder to get a good connection.
- 3 Immediately upon completing soldering, inspect area surrounding soldered connection. Check for solder "bridges" between the component you wanted to solder and components you do not want to solder. Make sure the solder you applied touches only the connection you intended to solder. Desolder and clean away any unintended bridges using hot soldering iron and dry cloth.

---

## 2-17 APPLICATION OF ADHESIVES

---

**WARNING**

Adhesives and solvents can burn easily, can give off harmful vapors, and are harmful to skin and clothing. To avoid injury or death, keep away from open fire and use in well-ventilated area. If adhesive or solvent gets on skin or clothing, wash immediately with soap and water.

**CAUTION**

Do not attempt to pull or pry on either bonded surface after mating. Damage to surfaces could result.

- a. Clean surface to be bonded. Surface must be free of grease, paint, talc, rust, soapstone, or any foreign substance.
- b. Stir adhesive unit fluid. Apply an even coat of adhesive to each mating surface. Let dry until tacky (about 20 minutes). Temperature and humidity will affect drying time.
- c. Apply another coat of adhesive to both previously coated surfaces. Let dry until tacky (about 20 minutes). Adhesive is the right consistency when it will not transfer to finger when touched lightly.
- d. Press mating surfaces together. Use a rubber roller or other suitable tool to ensure full contact between surfaces.

## 2-18 EXERCISING HYDRAULIC COMPONENTS

---

- a. Refer to TM 9-2350-311-10 for instructions on how to operate major hydraulic components for elevating the cannon and traversing the cab.
  - b. During testing, PMCS, and storage it is necessary to exercise hydraulic components to make sure they are operating properly. Refer to Appendix J for instructions on exercising the recoil system using the recoil exerciser.
  - c. Periodic operation of hydraulic components is necessary to maintain packings and seals in operating position, to replenish hydraulic fluid film on cylinder walls, to prevent rusting, corrosion, galling, and to prevent sticking or seizing of the pistons in their cylinders.
- 

## Section V. PREPARATION FOR STORAGE OR SHIPMENT

---

### 2-19 GENERAL

---

- a. Scope. The requirements specified here are necessary to maintain M109 series self-propelled howitzers in administrative storage at maximum readiness condition.
- b. Definition of Administrative Storage. The placement of equipment in administrative storage can be done for short periods of time when:
  - 1 An organization lacks operating funds, personnel, other resources, or normal usage of its organic materiel.
  - 2 Materiel which exceeds the capability of the owning organization to operate or maintain must be retained by that organization for contingency or other valid reasons.
- c. Authorization for Administrative Storage. Installation or organization commanders may authorize the administrative storage of their materiel within guidance furnished by MACOM commanders and AR 750-1. Howitzers should be ready for use within a 24-hour period or as otherwise prescribed by the approving authority.
- d. Records and Reports. Appropriate maintenance records will be kept during storage period. Records and reports to be maintained for equipment in administrative storage are prescribed by DA PAM 750-8. Asset reports will be submitted in accordance with AR 710-3.
- e. Inspections. Maintenance services and lubrications are in accordance with M109 series howitzers' operator's and maintenance manuals, or other applicable technical manual.
- f. Ten percent variance is acceptable on time-running hours or mileage used to determine maintenance actions required.

---

## 2-20 PRELIMINARY REQUIREMENTS

---

- a. Follow general administrative storage requirements as provided in AR 750-1 and administrative storage accountability requirements as provided in AR 710-2.
- b. Report administrative storage equipment in Materiel Condition Status Report and Unit Status as prescribed by AR 220-1 and AR 700-138.
- c. Ensure equipment placed in administrative storage is capable of performing its mission in accordance with AR 220-1 by completing the following:
  - 1 Correct all shortcomings and deficiencies prior to storage, or obtain a deferment from the approving authority.
  - 2 Perform the next scheduled major preventive maintenance service, prior to storage. Further preventive maintenance services are suspended while the howitzer is in administrative storage.
  - 3 Apply all modification work orders (MWOs).

---

## 2-21 RECEIPT FOR STORAGE

---

- a. When received for storage and already processed for domestic shipment by the manufacturer as indicated on DD Form 1397, the howitzer will not be reprocessed unless inspection performed on receipt of materiel reveals corrosion, deterioration, etc.
- b. Upon receipt from manufacturing facility, if the processing data on the tag indicates that preservation has been rendered ineffective by operation or by freight shipping damage, completely process the vehicle in accordance with MIL-H-46709.
- c. Immediately upon receipt of the vehicle for storage, it must be inspected and serviced as prescribed. Perform a systematic inspection. Replace or repair all missing or broken parts. If repairs are beyond the scope of the unit, and materiel will be inactivated for a considerable length of time, place materiel in limited storage and attach tags specifying the repairs needed.
- d. When materiel is inactivated for a limited time (not to exceed 90 days), it will be processed as normal.
- e. Prepare SF 364 for all shipments received in a damaged or otherwise unsatisfactory condition due to deficiencies in preservation, packaging, marking, handling, loading, or storage, and for apparently excessive preservation.

---

## 2-22 SECURITY

---

See AR 190-13, Army Physical Security Program and AR 190-15, Security of Army Property at Unit and Inspection Level, for security requirements that apply to classified or pilferable items.

## 2-23 STORAGE SITE

---

- a. Select the best available site for administrative storage. Separate stored equipment from equipment in use. Conspicuously mark the area "Administrative Storage".
  - b. The preferred storage site for vehicles is in dry covered sheds. When it is necessary to store materials outdoors, protect them against the elements as prescribed in TM 743-200.
  - c. Open sites should be improved hardstand, if available. Unimproved sites should be firm, well-drained, and kept free of excessive vegetation.
- 

## 2-24 STORAGE PLAN

---

- a. Store equipment so as to provide maximum protection from the elements and to provide access for inspection, maintenance, and exercising. Anticipate removal or deployment problems and take suitable precautions.
  - b. Take into account environmental conditions, such as extreme heat or cold; high humidity; blowing sand, dust, or loose debris; mud or soft ground; heavy snows; earthquakes; or combinations thereof, and take adequate precautions.
  - c. Establish a fire plan and provide for adequate firefighting equipment and personnel.
- 

## 2-25 AUXILIARY EQUIPMENT AND BASIC ISSUE ITEMS

---

Process auxiliary and basic issue items simultaneously with the howitzer to which they are assigned. If possible, store auxiliary and basic issue items with the howitzer. If not stored with the howitzer, mark auxiliary and basic issue items with tags indicating the howitzer, its registration or serial number, and location, and store in protective type closures. In addition, place a tag or list indicating the location of the removed items in a conspicuous place on the howitzer.

---

## 2-26 GENERAL CLEANING, PAINTING, AND PRESERVATION

---

**CAUTION**

- Do not direct water or steam under pressure against air cleaners, M2A2 air purifiers in M109A4/M109A5 howitzers, air duct outlets, exhaust outlets, unsealed electrical systems, fire control instruments, upholstery, or any exterior opening which will damage a component.
  - No removal of rust or damaged paint by scraping, wire brushing, sanding, or buffing is authorized on cannon, fire control, or other armament components. Damage to components could result.
- a. Clean the equipment of dirt, grease, and other contaminants in accordance with para 2-12.
  - b. After cleaning and drying, immediately coat unpainted metal surfaces with an oil or grease as appropriate.

<b>WARNING</b>
----------------

CARC paint is extremely hazardous. Refer to appropriate warnings listed in the front of this manual.

**NOTE**

Touch up painting will be in accordance with TM 43–0139. CARC painted vehicles will have the letters CARC stenciled next to vehicle ID plate.

- c. Perform a visual inspection periodically to determine general condition. If corrosion is found, remove it and clean spot. Paint and treat vehicles with the prescribed preservations.

**NOTE**

- Air circulation under draped covers reduces deterioration from moisture and heat.
  - Place a piece of barrier material between desiccant bags and metal surfaces.
- d. Sunlight, heat, moisture (humidity), and dirt tend to accelerate deterioration. Install all covers (including vehicle protection closures) authorized for the equipment. Close and secure all openings except those required for venting and draining. Seal openings to prevent the entry of rain, snow, or dust. Insert desiccant when complete seal is required. Position equipment and provide blocking or framing to allow for ventilation and water drainage. Keep cover raised above howitzer to allow air to circulate, preventing rust, rot, or mildew.

---

## 2–27 PREPARATION OF CANNON, FIRE CONTROL INSTRUMENTS, AND AUTOMOTIVE EQUIPMENT

---

a. Cannon

- 1 Thoroughly clean, dry, and coat the inside of cannon tube with preservation oil (item 8, Appx D) and insert a strip of volatile corrosion inhibitor (VCI) paper the full length of the cannon tube. Seal breech and muzzle to sustain VCI benefits.
- 2 Remove, clean, and dry bore evacuator chambers. Apply preservative oil (item 8, Appx D) to all machined surfaces on the bore evacuator and the cannon tube. Replace the bore evacuator on the cannon tube. Do no wrap or tape bore evacuator.
- 3 Remove, clean, and dry muzzle brake. Coat the muzzle brake lock, key, hardware, and unpainted surfaces of the muzzle brake with grease, automotive and artillery (GAA) (item 18, Appx D). Reassemble and wrap muzzle brake with pressure-sensitive tape (item 39, Appx D).

**NOTE**

Breech mechanism of cannon is protected by the cab and does not need to be wrapped.

- 4 Wrap end of cannon tube with barrier material and seal with tape (item 39, Appx D).
- 5 Thoroughly clean and dry breech, breech ring, and breechblock before coating with GAA (item 18, Appx D). Set the breechblock in the closed position.



---

## 2-27 PREPARATION OF CANNON, FIRE CONTROL INSTRUMENTS, AND AUTOMOTIVE EQUIPMENT — CONTINUED

---

b. Fire Control Instruments

- 1 Thoroughly clean and dry fire control instruments and coat unpainted surfaces with GAA (item 18, Appx D).
- 2 Wrap all optical glass with lens tissue and fasten with tape.
- 3 Store all instruments on racks, in cases, or with protective covers.

c. Preparation of Automotive Equipment

- 1 Fuel tanks.
  - (a) Fill fuel tanks to maximum allowable level. Ventilate unvented fuel systems by releasing filler cap to the first position.
  - (b) If local fire regulations prohibit storing equipment with fuel in system, completely drain the fuel tanks.
- 2 Lead-acid batteries.

Leave batteries in place on equipment. Disconnect one terminal/connector. Ensure that the batteries are fully charged when equipment is stored and returned to full charge during each equipment exercising.

---

## 2-28 CARE OF EQUIPMENT IN ADMINISTRATIVE STORAGE

---

- a. After equipment has been placed in administrative storage, suspend all regularly scheduled preventive maintenance services and inspect and exercise as specified herein. Do not reduce Prescribed Load List.

**CAUTION**

Opening the breechblock with the spring tension released will cause the carrier to slam open and possibly be damaged.

- b. Release pre-load on closing spring using adjustable wrench or spanner wrench. Apply clockwise pressure on adjuster and depress adjuster plunger. Rotate adjuster slowly counterclockwise until all torque has been relieved.

---

## 2-29 INSPECTION

---

- a. Vehicle to be prepared for administrative storage must be given a limited technical inspection and processed as prescribed on DD Form 1397. The results of the inspection and classification will be entered on DA Form 2404.
- b. If a vehicle is not shipped or issued upon expiration of the limited storage period, process as applicable in accordance with MIL-H-46709.
- c. If a vehicle to be shipped will reach its destination within the limited storage period, it need not be reprocessed when removed from storage, unless anticipated in-transit weather conditions make it necessary.

- d. Inspection will usually be visual and must consist of at least a walk-around examination of all equipment to observe any deficiencies that may have occurred. Inspect equipment in open storage weekly and equipment in covered storage monthly. Inspect all equipment immediately after any severe storm or environmental change. The following are examples of things to look for during visual inspection.
- 1 Leaks: coolant, fuel, oil, or hydraulic fluid.
  - 2 Condition of preservatives, seals, and wraps. Seals may develop leaks during storage, during exercise, or shortly thereafter. If leaking continues, refer to the repair procedures in this manual or notify support maintenance.
  - 3 Corrosion or other deterioration.
  - 4 Missing or damaged parts.
  - 5 Water in compartments.
  - 6 Any other obvious shortcomings or deficiencies.
  - 7 If unsatisfactory conditions occur, and are beyond unit maintenance capabilities, notify support maintenance.
- e. Purge and charge fire control instruments as required (TM 750-116).
- f. Inspect cannon at the time recoil mechanisms and equilibrators are exercised.
- 

## 2-30 EXERCISING

---

Exercise equipment before administrative storage if schedule calls for exercising during administrative storage. Refer to Appendix J for instructions on exercising the recoil system using the recoil exerciser. Refer to TB 9-1000-234-13 for requirements on exercising the recoil system. Limit depreservation to removal of materials that will restrict exercising. Perform the before, during, and after operational checks in accordance with TM 9-2350-311-10. Take immediate action to correct shortcomings and deficiencies noted. Exercise all hydraulic units when exercising the vehicle. Notify support maintenance before exercising vehicle. Note inspection results on DA Form 2404 and exercise results on DD Form 1970. Record and report maintenance actions on DA Form 2407. After exercising, replenish fuel and note on DD Form 1970. Replenish oil used during exercising and note the amount on DA Form 2408-20.

---

## 2-31 ROTATION

---

To assure use of all assigned materiel, rotate items in accordance with any rotational plan that will keep howitzer in an operational condition and reduce maintenance.

## 2-32 REMOVAL FROM ADMINISTRATIVE STORAGE

---

- a. Restore vehicle to normal operating condition, including removing preservative materials and applying any new MWOs.
  - b. Return to normal PMCS schedule.
  - c. Calibrate items if required.
  - d. Prepare equipment for service as outlined in TM 9-2350-311-10 and in accordance with instructions on DD Form 1397.
- 

## 2-33 SERVICING

---

Resume the maintenance service schedule in effect at the commencement of storage per DD Form 314. See DA PAM 750-8.

---

## 2-34 SHIPPING PREPARATION

---

- a. Preparation for Shipment

When shipping the self-propelled howitzer, the officer in charge of preparing the shipment will be responsible for furnishing the materiel in serviceable condition, properly cleaned, processed, packaged, and packed.

- b. Removal of Preservatives Prior to Shipment

Personnel withdrawing the vehicle from storage for shipment must not remove preservatives other than to ensure that the materiel is complete and serviceable. If preservatives have been removed, they must be restored to prescribed level of preservation prior to shipment.

- c. Army Shipping Documents

Prepare all Army shipping documents in accordance with AR 55-355.

---

## 2-35 LOADING VEHICLE FOR SHIPMENT

---

<b>CAUTION</b>
----------------

- The height and width of a vehicle, when prepared for rail transportation, must not exceed the limitations prescribed for particular railroad lines. Whenever possible, local transportation officers must be consulted about the limitations of the particular railroad lines to be used for the movement in order to avoid delays, dangerous conditions, or damage to equipment.
- The howitzer cannon must never extend beyond end of flatcar to avoid possible damage to howitzer.

When a vehicle is shipped by rail, every precaution must be taken to see that it is properly loaded, blocked, and securely fastened to flatcar floor.

Inspect flatcar prior to loading and see that it is in a suitable condition to carry loads safely.

Prepare flatcar for loading by removing debris, previous blocking, nails, and other obstructions. Inspect flatcar for loose or broken floor planks. If found unsatisfactory, reject the car for use.

If suitable hoisting equipment, permanent loading ramps, and handling equipment are not available for loading or unloading materiel, improvised runways, ramps, and spanning platforms can be constructed.

Loading must be governed by the capacity and length of flatcars available at time of shipment, as well as requirements of bills of lading and shipping instructions.

Position the vehicle as far from the brake wheel end of the flatcar as space permits. Provide a minimum clearance of 4 inches (10.2 cm) below and 6 inches (15.2 cm) above, behind, and to each side of the flatcar brake wheel.

---

## 2-36 BLOCKING

---

### a. General

All blocking instructions specified herein are minimum and are in accordance with the Association of American Railroads Pamphlet, Section No. 6, Rules Governing the Loading of Department of Defense Materiel on Open-Top Cars. Additional blocking may be added at the discretion of the officer in charge.

### b. Track Inside Cleats

Locate two cleats (6 in. x 6 in. x 14 ft) (15.2 cm x 15.2 cm x 4.3 m) along the inside of the left and right tracks. Nail to car floor with 30-penny nails, staggered approximately every 12 inches (30.4 cm).

### c. Chock Block

Construct four chock blocks; two to fit the angle between the tracks and car deck at the front of the vehicle and two to fit the angle between the track and car deck at the rear of the vehicle. Using 1-5/8 inches (4.1 cm) thick lumber, make chock blocks 12 inches (30.4 cm) wide and a minimum of 18 inches (45.72 cm) high. Nail pieces together with 20-penny nails. Locate one chock block against the front of each track and one against the rear of each track. Toenail the chock blocks to the car floor with 40-penny nails.

**2-36 BLOCKING — CONTINUED**

d. End Cleats

Locate one cleat 2 in. x 4 in. x 12 in. (5 cm x 10.2 cm x 30.4 cm), against the end of each chock block (eight cleats required) and secure to car deck with 30-penny nails. Locate the upper cleat on top of the lower cleat and secure to lower cleat with 30-penny nails.

e. Side Cleats

Locate one cleat 2 in. x 3 in. x 10 in. (5 cm x 7.6 cm x 25 cm), against the inside and outside of each of the chock blocks (eight cleats required). Secure each to car deck with 20-penny nails.

**CAUTION**

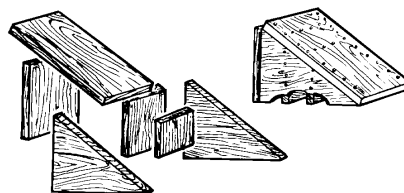
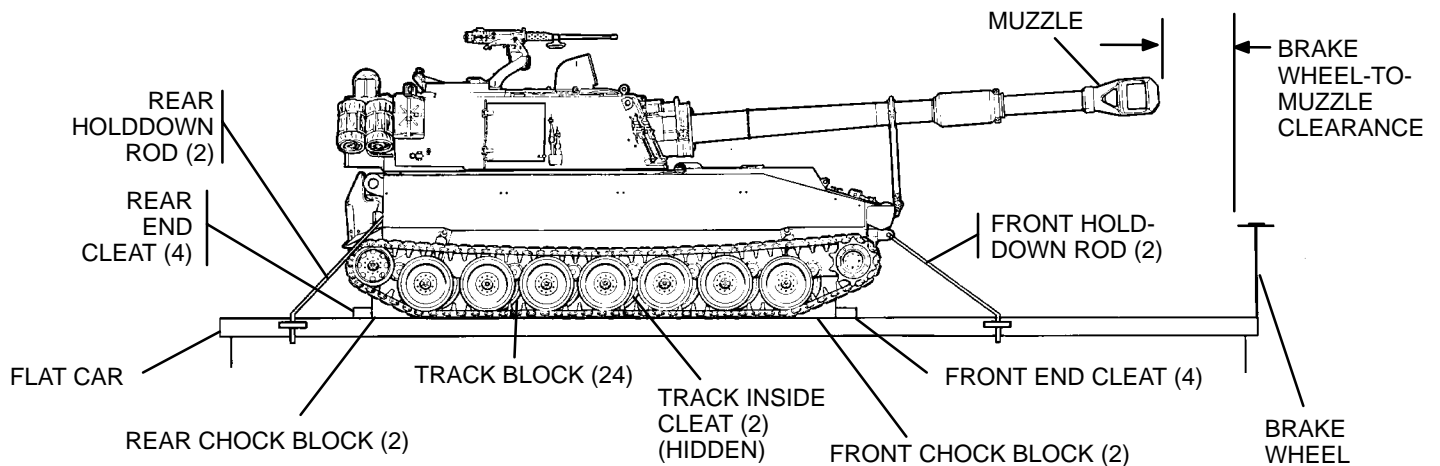
Make sure cannon tube is securely locked in TRAVEL LOCK and CAB TRAVEL LOCK is engaged to avoid damage to howitzer.

f. Track Blocks

Cut 34 blocks to conform with the shape of road wheels. Locate blocks on tracks between wheels. Place wedges under block to ensure a snug fit against wheels, if required. Nail 2 in. x 4 in. (5 cm x 10.2 cm) cleat (length to suit) across top of blocks to prevent track blocks from sliding out of position.

g. Holddown Rods

Thread both ends of rod 1-1/4 inches (3.2 cm) diameter, length to suit. Insert one end of rod through lifting eye on front of vehicle. Bend rod and insert other end through stake pocket on opposite side of flatcar. Repeat operation with second rod and lifting eye on front of vehicle. Repeat operations with two rods on rear of vehicle.



CHOCK BLOCK-EXPLODED AND ASSEMBLED VIEWS

## CHAPTER 3 TROUBLESHOOTING

### GENERAL

This chapter contains troubleshooting, test, and repair information needed to correct equipment malfunctions of the M109 series howitzer at the unit maintenance level.

<u>CONTENTS</u>	<u>Page</u>
3-1 INITIAL SETUP .....	3-1
3-2 QUICK GUIDE TO TROUBLESHOOTING .....	3-1
3-3 TROUBLESHOOTING CHART .....	3-5

### 3-1 INITIAL SETUP

#### 3-1.1 Pre-Troubleshooting Procedures (TM 9-2350-311-10)

- a. Park the vehicle on level ground, place the transmission in NEUTRAL, and set the parking brake.
- b. Put the gun in TRAVEL LOCK position, set the cab in TRAVERSE LOCK position, and turn the engine off.
- c. Make sure all weapons have been unloaded, the bore is clear, and there is no primer.
- d. Walk around the vehicle and check to make sure there are no obstacles blocking the cab or vehicle.

#### 3-1.2 Troubleshooting Task Initial Setup

Tools, materials/parts, and any conditions necessary to complete a troubleshooting task will be listed at the beginning of each troubleshooting tree.

### 3-2 QUICK GUIDE TO TROUBLESHOOTING

#### 3-2.1 Contents of Quick Guide to Troubleshooting

The QUICK GUIDE TO TROUBLESHOOTING lists the items to check, possible symptoms with each item, and a reference to a paragraph where a corrective action for the problem can be found.

**3-2 QUICK GUIDE TO TROUBLESHOOTING — CONTINUED**

**3-2.2 General Troubleshooting Procedures**

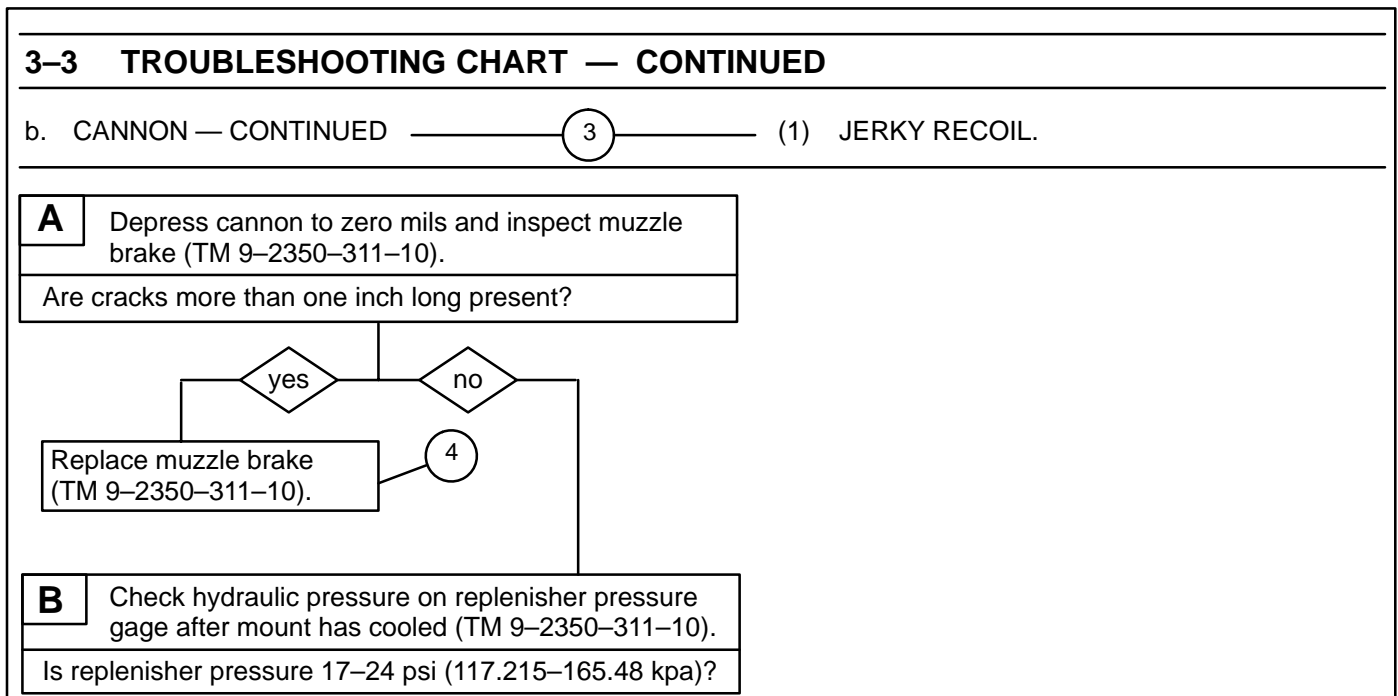
Refer to the samples below and follow these instructions for using the QUICK GUIDE TO TROUBLESHOOTING (sample A) and troubleshooting procedures (sample B). If any problem is not listed or will not correct through troubleshooting, notify support maintenance.

- a. Determine the symptom.
- b. Locate the symptom (1) in the Quick Guide to Troubleshooting.
- c. Locate the troubleshooting paragraph (2) reference for your symptom or maintenance action.
- d. Turn to the troubleshooting procedure (3) identified in the Quick Guide to Troubleshooting.
- e. Study the function description, pictorial view, and electrical schematic located at the beginning of each section.
- f. Perform corrective action (4) as required by troubleshooting procedure.
- g. Verify that the corrective action eliminated the symptom.

**SAMPLE A**

3-2 QUICK GUIDE TO TROUBLESHOOTING — CONTINUED		
ITEM	1 SYMPTOM	2 PARAGRAPH
CANNON	JERKY RECOIL.	3-3b. (1)
CAB HYDRAULIC SYSTEM	HYDRAULIC PUMP MOTOR OPERATES WHEN MASTER SWITCH IS ON AND CAB POWER SWITCH IS OFF. Replace electromagnetic relay in power relay box assembly.	8-12

**SAMPLE B**



3-2.3

Quick Guide to Troubleshooting List

ITEM	SYMPTOM	PARAGRAPH	
BREECH MECHANISM	BREECH DOES NOT OPEN MANUALLY.	3-3a. (1)	
	BREECH DOES NOT CLOSE COMPLETELY.	3-3a. (2)	
	BREECH DOES NOT OPEN AUTOMATICALLY AFTER FIRING.	3-3a. (3)	
CANNON	JERKY RECOIL.	3-3b. (1)	
	EXCESSIVE RECOIL FORCE.	3-3b. (2)	
	EXCESSIVE RECOIL TRAVEL AT HIGH ANGLE OF FIRE.	3-3b. (3)	
	CANNON DOES NOT RETURN TO BATTERY.	3-3b. (4)	
	PRIMER DOES NOT FIRE.	3-3b. (5)	
	PRIMER NOT EJECTED PROPERLY. Replace cartridge extractor.	5-4	
	CAB FILLS WITH SMOKE OR GASES AFTER FIRING.	3-3b. (6)	
	BORE EVACUATOR OR MUZZLE BRAKE THRUST COLLAR BECOMES LOOSE. Replace setscrew, spring, or bearing ball.	5-1	
	CAB TRAVERSING SYSTEM	CAB WILL NOT TRAVERSE UNDER POWER OR MANUALLY, BUT HYDRAULIC PRESSURE IS NORMAL AND CAB LIGHTING OPERATES.	3-3c. (1)
		MANUAL TRAVERSE HANDWHEEL ROTATES WHILE TRAVERSING IN POWER.	3-3c. (2)
CAB WILL NOT TRAVERSE UNDER POWER, MANUAL OPERATION IS NORMAL.		3-3c. (2.1)	
CAB TRAVERSES UNDER POWER, BUT TRAVERSE CONTROL INDICATOR LAMP DOES NOT LIGHT.		3-3c. (3)	
CAB WILL NOT TRAVERSE FREELY IN MANUAL OR POWER MODES.		3-3c. (4)	
CAB CREEPS.		3-3c. (5)	
ELEVATING SYSTEM		CANNON DOES NOT ELEVATE OR DEPRESS UNDER POWER OR MANUALLY, BUT HYDRAULIC PRESSURE IS NORMAL.	3-3d. (1)
	CANNON MOVES BY ONLY ONE CONTROL HANDLE, BUT MANUAL OPERATION IS NORMAL.	3-3d. (2)	
	CANNON WILL NOT MOVE UNDER POWER FROM EITHER CONTROL HANDLE, BUT MANUAL OPERATION IS NORMAL. Notify support maintenance.		
	CANNON DOES NOT ELEVATE OR DEPRESS SMOOTHLY.	3-3d. (3)	
	CANNON DOES NOT ELEVATE OR DEPRESS USING MANUAL ELEVATION SYSTEM OR SYSTEM IS INEFFICIENT, BUT CANNON WILL OPERATE UNDER POWER.	3-3d. (4)	
CAB HYDRAULIC SYSTEM	POWER PACK HYDRAULIC PUMP MOTOR DOES NOT OPERATE, BUT CAB LIGHTING SYSTEM OPERATES NORMALLY.	3-3e. (1)	
	HYDRAULIC PRESSURE IS NORMAL, BUT HYDRAULIC POWER IS NOT BEING SUPPLIED.	3-3e. (2)	
	HYDRAULIC FLUID OVERFLOWS FROM TOP OF SIGHT GAGE OR CONTAMINATED CRYSTALS IN HYDROSCOPIC BREATHER.	3-3e. (3)	
	HYDRAULIC PUMP MOTOR ON/OFF CYCLE IS RAPID.	3-3e. (4)	
	HYDRAULIC PUMP MOTOR OPERATES WHEN MASTER SWITCH IS ON AND CAB POWER SWITCH IS OFF. Replace electromagnetic relay in power relay box assembly.	8-13	



**3-2 QUICK GUIDE TO TROUBLESHOOTING — CONTINUED**

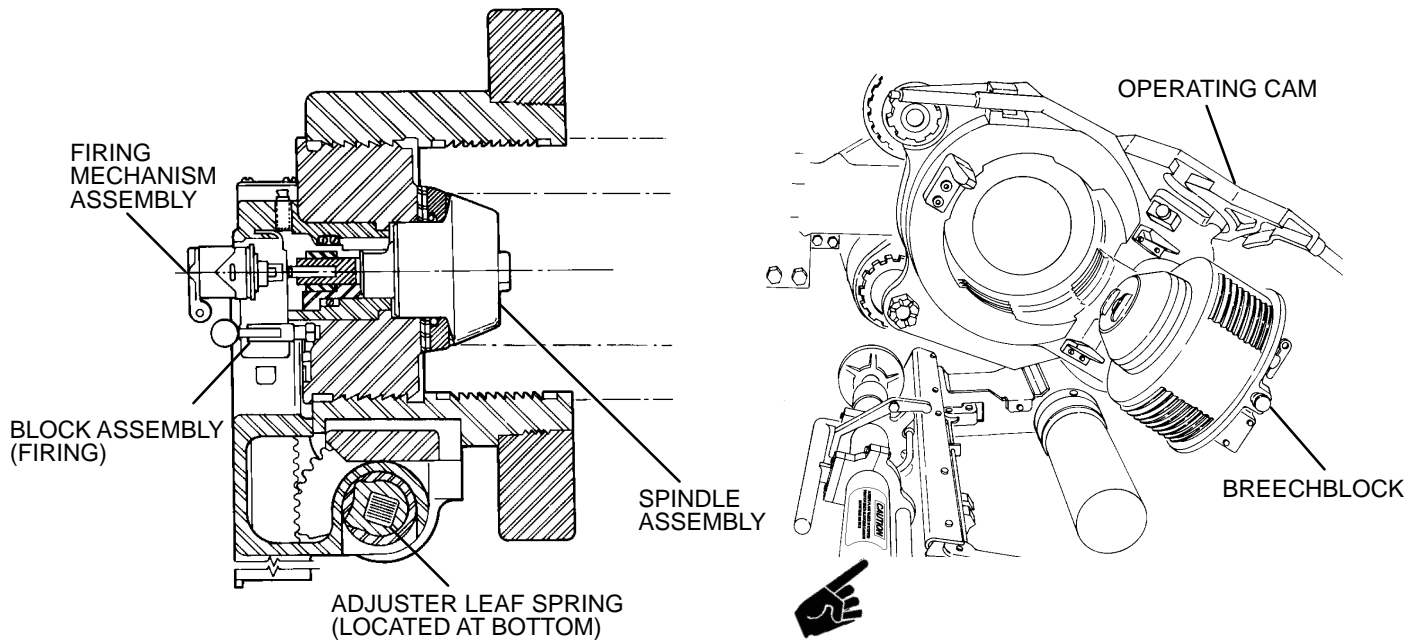
CAB HYDRAULIC SYSTEM – Continued	POWER PACK OPERATES CONTINUOUSLY WHEN CAB POWER AND MASTER SWITCHES ARE ON.	3-3e. (5)
	MAIN ACCUMULATOR WILL NOT HOLD DRY NITROGEN CHARGE. Notify support maintenance.	
	GUNNER'S OR ASSISTANT GUNNER'S CONTROL HANDLE DOES NOT RETURN TO NEUTRAL POSITION WHEN RELEASED.	3-3e. (6)
RAMMER HYDRAULIC SYSTEM	RAMMER DOES NOT OPERATE.	3-3f. (1)
CAB POWER SYSTEM	ALL CAB ELECTRICAL COMPONENTS FAIL TO OPERATE.	3-3g. (1)
	CAB ELECTRICAL COMPONENTS OPERATE NORMALLY, BUT CAB POWER INDICATOR LIGHT DOES NOT ILLUMINATE.	3-3g. (2)
CAB LIGHTING SYSTEM	ONE OR MORE DOME LIGHTS ARE OUT, BUT SIGHTING EQUIPMENT LIGHTS OPERATE.	3-3h. (1)
	M118A2/M118A3 ELBOW TELESCOPE LIGHT IS OUT, BUT ALL OTHER LIGHTS OPERATE.	3-3h. (2)
	M145/M145A1 TELESCOPE MOUNT AND M117/M117A2 PANORAMIC TELESCOPE LIGHTS ARE OUT, BUT ALL OTHER LIGHTS OPERATE.	3-3h. (3)
	M15 ELEVATION QUADRANT LIGHT IS OUT, BUT ALL OTHER LIGHTS OPERATE.	3-3h. (4)
	ALL CAB LIGHTS ARE OUT.	3-3h. (5)
INTERCOMMUNICATION SYSTEM	INTERCOMMUNICATION SYSTEM WILL NOT OPERATE.	3-3i. (1)
	AMPLIFIER AM1780/VRC DOES NOT KEY WHEN MIC BUTTON IS PUSHED.	3-3i. (2)
	DRIVER CANNOT COMMUNICATE.	3-3i. (3)
	OPERATOR CANNOT COMMUNICATE AT GUNNER'S OR COMMANDER'S CONTROL BOX.	3-3i. (4)
	TELEPHONE OPERATOR CANNOT COMMUNICATE.	3-3i. (5)
NBC SYSTEM CIRCUIT	NBC CONTROL BOX ASSEMBLY INDICATOR LIGHT DOES NOT ILLUMINATE, BUT NBC SYSTEM OPERATES.	3-3j. (1)
	NBC SYSTEM DOES NOT OPERATE.	3-3j. (2)
	NBC CONTROL BOX ASSEMBLY INDICATOR LIGHT ILLUMINATES, BUT M2A2 AIR PURIFIER DOES NOT OPERATE.	3-3j. (3)
	NBC CONTROL BOX ASSEMBLY INDICATOR LIGHT ILLUMINATES, BUT GUNNER'S M3 ELECTRICAL AIR HEATER DOES NOT OPERATE.	3-3j. (4)
	NBC CONTROL BOX ASSEMBLY INDICATOR LIGHT ILLUMINATES, BUT CANNONEER NO. 1'S M3 ELECTRICAL AIR HEATER DOES NOT OPERATE.	3-3j. (5)
	NBC CONTROL BOX ASSEMBLY INDICATOR LIGHT ILLUMINATES, BUT SECTION CHIEF'S M3 ELECTRICAL AIR HEATER DOES NOT OPERATE.	3-3 (6)
	NBC CONTROL BOX ASSEMBLY INDICATOR LIGHT ILLUMINATES, BUT ASSISTANT GUNNER'S M3 ELECTRICAL AIR HEATER DOES NOT OPERATE.	3-3j. (7)

### 3-3 TROUBLESHOOTING CHART

a. BREECH MECHANISM

The breech mechanism consists of the breech operating handle with detent plunger, cradle cam, clutch pin, firing mechanism block assembly with firing mechanism, and spring pack. Below is a pictorial view of the breech mechanism.

The breech operating handle is used to open the breech prior to firing. The breech will open automatically after firing of the cannon. The cradle cam is used to close the breech. The firing mechanism is used with a primer to fire the cannon.



**3-3 TROUBLESHOOTING CHART — CONTINUED**

a. BREECH MECHANISM — CONTINUED

(1) BREECH DOES NOT OPEN MANUALLY.

**INITIAL SETUP**

Tools

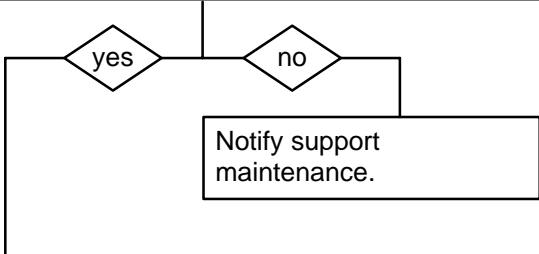
Artillery and turret mechanic's tool kit  
(SC 5180-95-CL-A12)

Spanner wrench (item 17, Appx H)

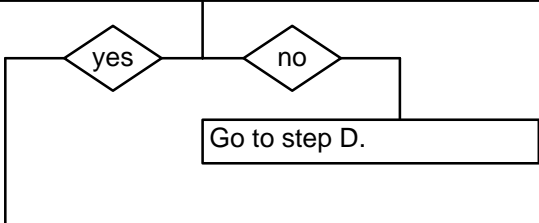
References

TM 9-2350-311-10

**A** Check the operating handle plunger and operating handle clutch for proper operation (TM 9-2350-311-10).  
Do they operate properly?

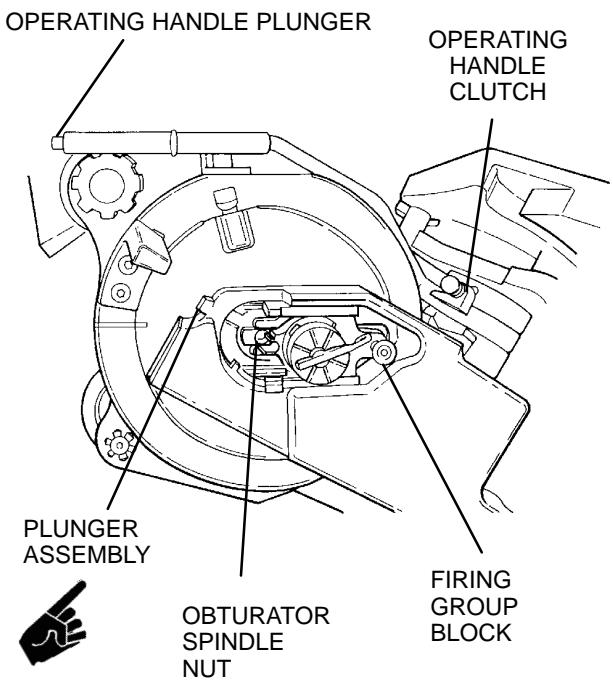


**B** 1. Slide firing group block to the right OPEN position.  
2. Disengage plunger assembly from obturator spindle nut (para 5-7).  
3. Check obturator spindle nut for looseness.  
Is obturator spindle nut loose?

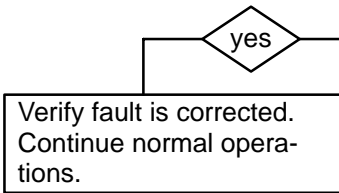


**C** 1. Tighten obturator spindle nut using spanner wrench.  
2. Engage plunger assembly with obturator spindle nut (para 5-7).  
3. Attempt to open breech.  
Does breech open?

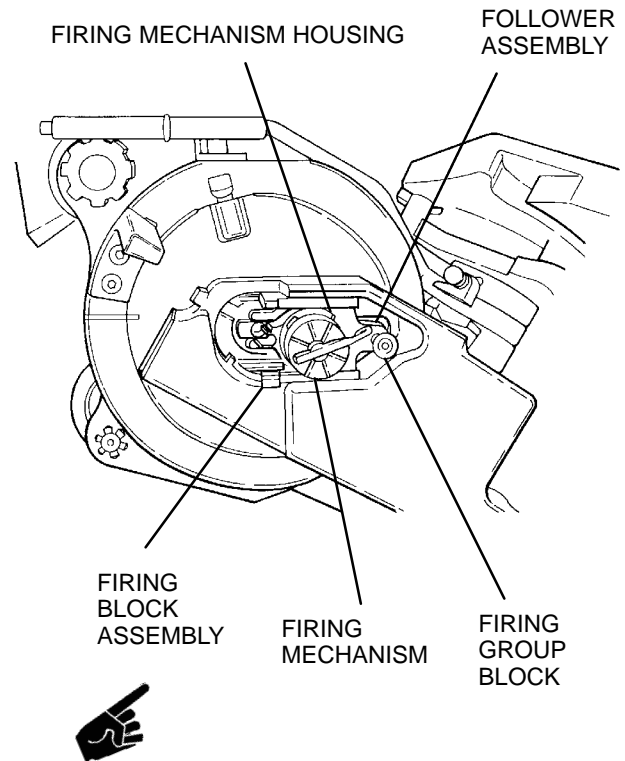
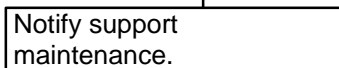
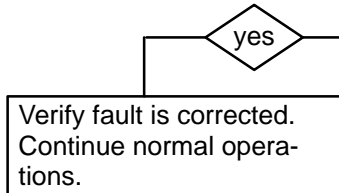
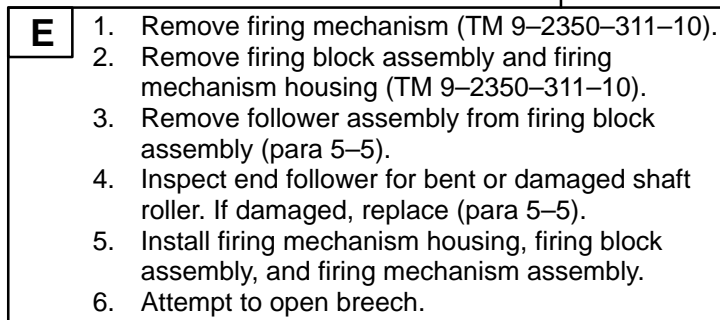
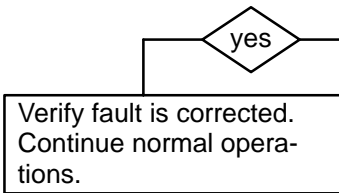
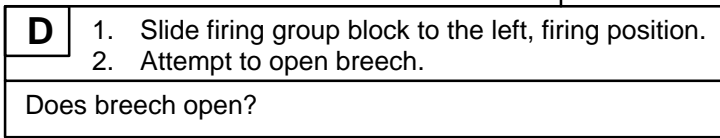
CONTINUED ON NEXT PAGE



CONTINUED FROM STEP C



CONTINUED FROM STEP B OR C



END OF TASK

**3-3 TROUBLESHOOTING CHART — CONTINUED**

a. BREECH MECHANISM — CONTINUED

(2) BREECH DOES NOT CLOSE COMPLETELY.

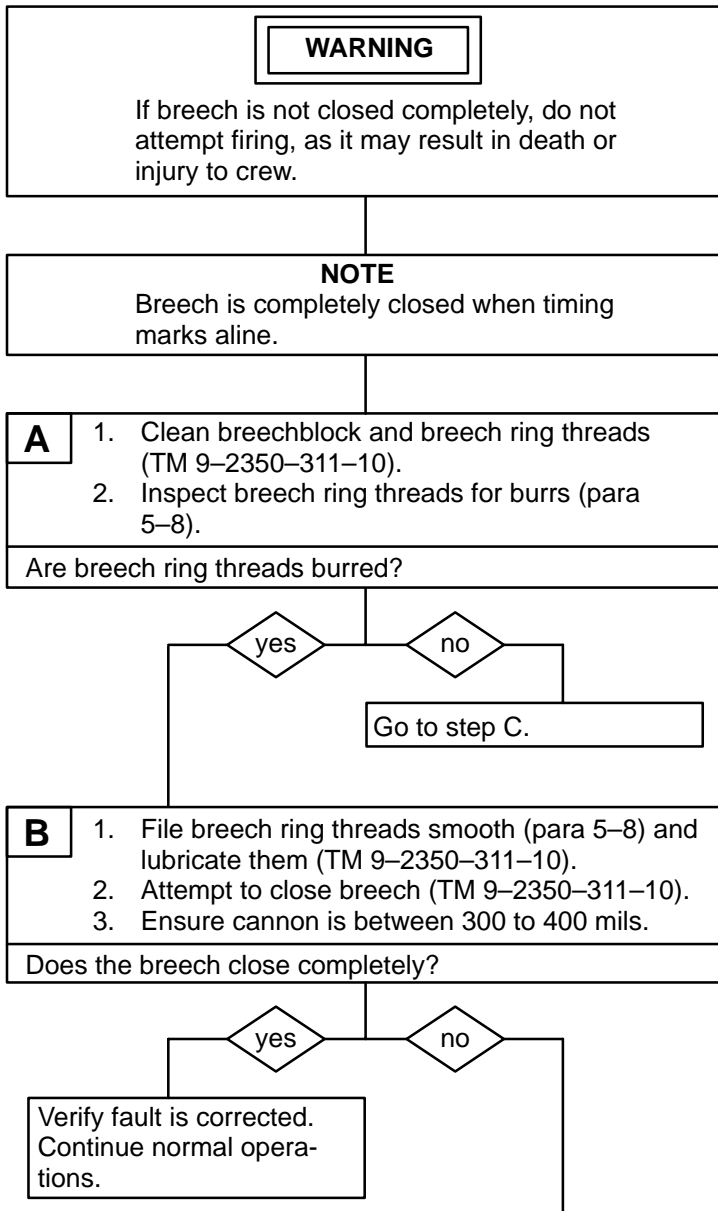
**INITIAL SETUP**

Tools

Artillery and turret mechanic's tool kit  
(SC 5180-95-CL-A12)

References

TM 9-2350-311-10



CONTINUED ON NEXT PAGE

CONTINUED FROM STEP A OR B

**C** Adjust closing spring tension at leaf spring adjuster (TM 9-2350-311-10).

Does leaf spring adjuster rotate past third notch?

yes

no

If timing marks align, breech is fully closed. If not, go to para 5-12.

- D**
1. Remove and inspect leaf springs (para 5-6).
  2. Replace damaged or fatigued leaf springs (para 5-6).
  3. Attempt to close breech (TM 9-2350-311-10).

Does breech close completely?

yes

no

Verify fault is corrected. Continue normal operations.

- E**
1. Remove and inspect obturator pad. Replace if necessary (para 5-7).
  2. Attempt to close breech (TM 9-2350-311-10).

Does breech close completely?

yes

no

Verify fault is corrected. Continue normal operations.

CONTINUED ON NEXT PAGE

---

### 3-3 TROUBLESHOOTING CHART — CONTINUED

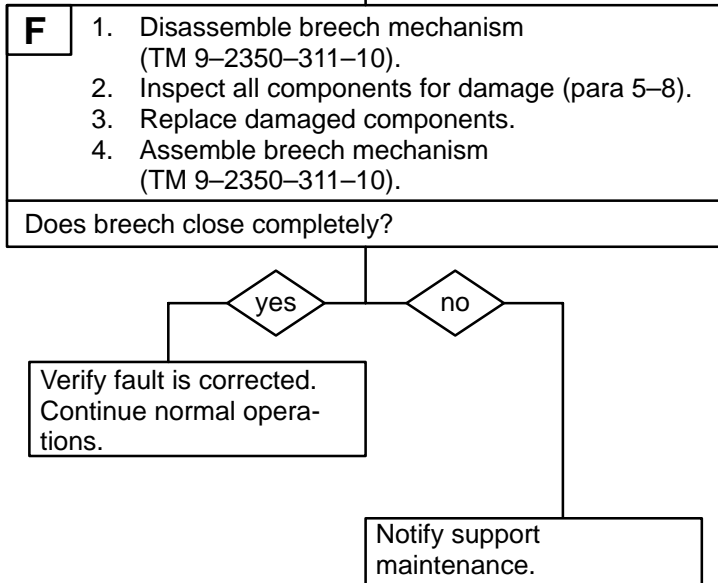
---

a. BREECH MECHANISM — CONTINUED

(2) BREECH DOES NOT CLOSE COMPLETELY.  
— CONTINUED

---

CONTINUED FROM STEP E



**END OF TASK**

a. BREECH MECHANISM — CONTINUED

(3) BREECH DOES NOT OPEN AUTOMATICALLY AFTER FIRING.

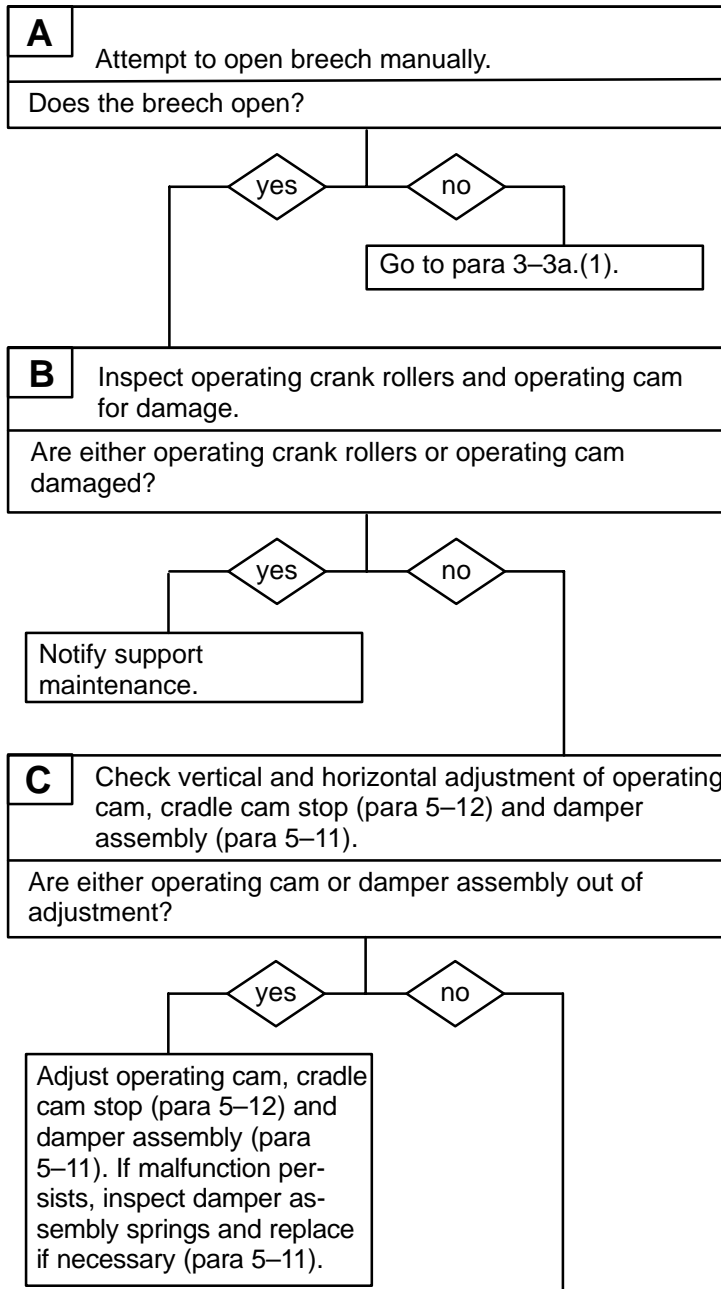
**INITIAL SETUP**

Tools

Artillery and turret mechanic's tool kit  
(SC 5180-95-CL-A12)

References

TM 9-2350-311-10



CONTINUED ON NEXT PAGE



---

### 3-3 TROUBLESHOOTING CHART — CONTINUED

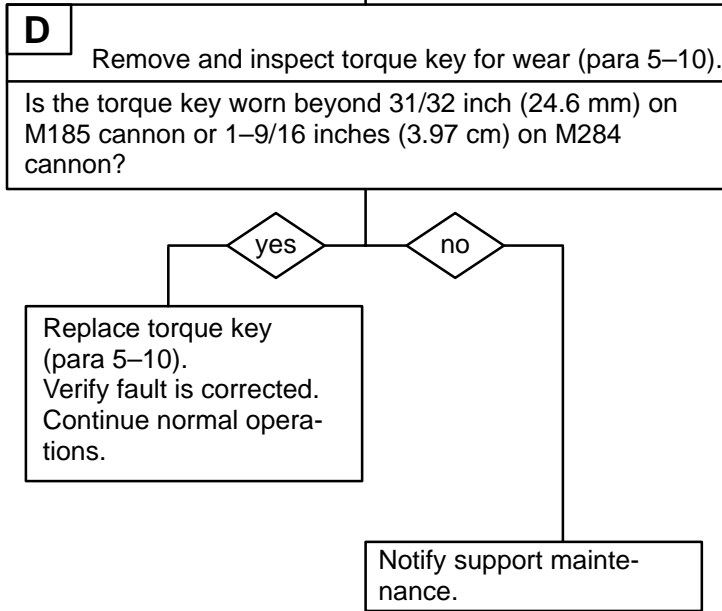
---

a. BREECH MECHANISM — CONTINUED

(3) BREECH DOES NOT OPEN AUTOMATICALLY AFTER FIRING. — CONTINUED

---

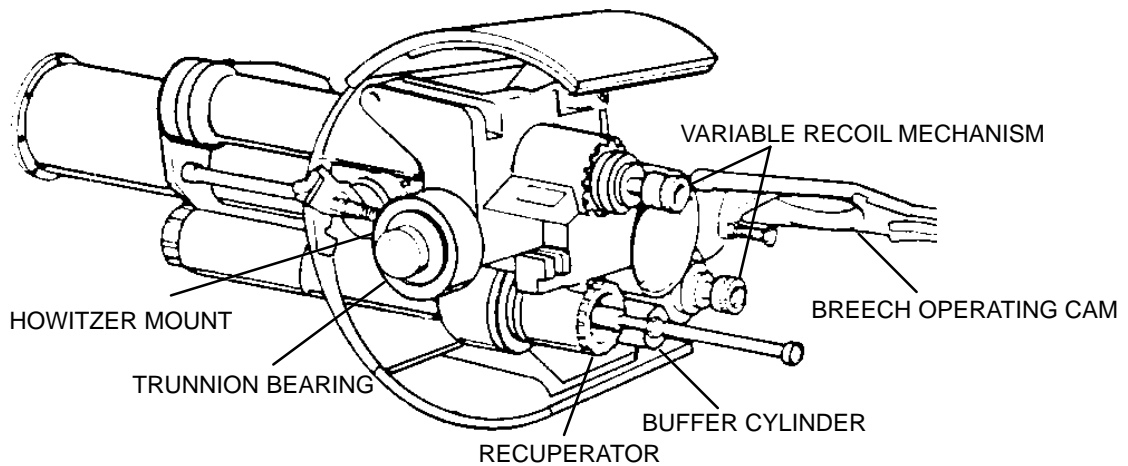
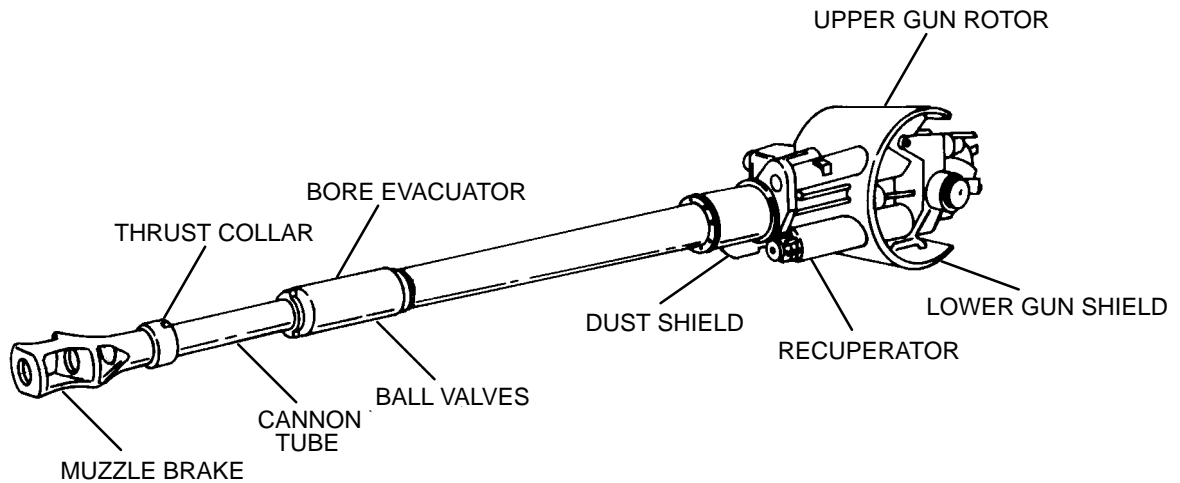
CONTINUED FROM STEP C



**END OF TASK**

b. Cannon

The cannon consists of the muzzle brake, thrust collar, cannon tube, bore evacuator, mount, variable recoil mechanism, breech assembly and firing mechanism. Below is a pictorial view of the cannon with all the major assemblies installed. The muzzle brake and variable recoil mechanism reduce and absorb the recoil of the cannon tube during the firing sequence. The breech assembly houses the projectile and propellant during a firing. The firing mechanism is used to fire the cannon.



---

### 3-3 TROUBLESHOOTING CHART — CONTINUED

---

b. CANNON — CONTINUED

(1) JERKY RECOIL.

---

#### **INITIAL SETUP**

Tools

Artillery and turret mechanic's tool kit  
(SC 5180-95-CL-A12)

Personnel Required

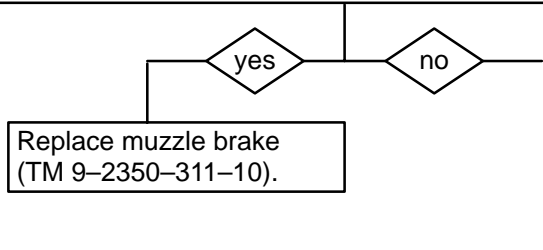
2

References

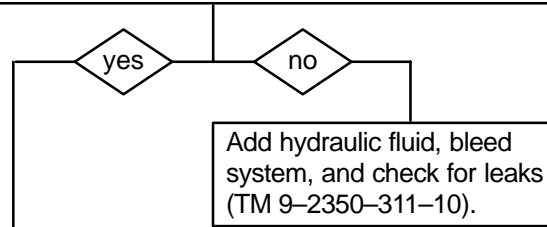
TM 9-2350-311-10

---

**A** Depress cannon assembly to zero mils and inspect muzzle brake (TM 9-2350-311-10).  
Are cracks more than 1 inch (2.54 cm) long present?



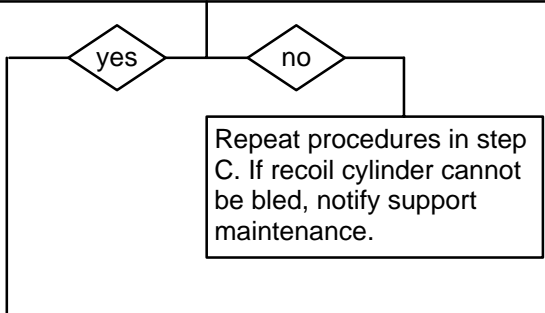
**B** Check hydraulic pressure on replenisher pressure gage after mount has cooled (TM 9-2350-311-10).  
Is replenisher pressure 17-24 psi (117.215-165.48 kpa)?



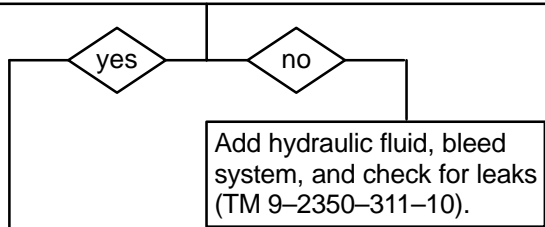
CONTINUED ON NEXT PAGE

CONTINUED FROM STEP B

<b>C</b>	<ol style="list-style-type: none"> <li>1. Using manual elevation handle, depress cannon assembly to maximum depression (TM 9-2350-311-10).</li> <li>2. Loosen right-hand bleed plug and bleed trapped air from rear of buffer. Tighten right-hand bleed plug when air-free fluid flows (TM 9-2350-311-10).</li> <li>3. Using manual elevation handle, elevate cannon assembly to 50 mils (TM 9-2350-311-10).</li> <li>4. Loosen left-bleed plug and bleed trapped air from front of buffer. Tighten left-hand bleed plug when air-free fluid flows (TM 9-2350-311-10).</li> <li>5. Using manual elevation handle, elevate cannon assembly to 180 mils (TM 9-2350-311-10).</li> <li>6. Loosen bleed plug on bleeder tee and bleed trapped air until air-free fluid flows. Tighten bleed plug (TM 9-2350-311-10).</li> </ol>
Does air-free fluid flow?	



<b>D</b>	Check hydraulic pressure on replenisher pressure gage (TM 9-2350-311-10).
Is replenisher pressure 17-24 psi (117.215-165.48 kpa)?	



CONTINUED ON NEXT PAGE

3-3 TROUBLESHOOTING CHART — CONTINUED

b. CANNON — CONTINUED

(1) JERKY RECOIL. — CONTINUED

CONTINUED FROM STEP D

**E** DELETED.

- F**
1. Service cradle sleeve bearings (TM 9-2350-311-10).
  2. Inspect buffer assembly (para 5-17).
  3. Check and service recuperator pins (TM 9-2350-311-10).
  4. Return vehicle to firing ready condition (TM 9-2350-311-10).
  5. Fire cannon in accordance with (TM 9-2350-311-10).

Does cannon have jerky recoil?

yes

no

Notify support maintenance.

Verify fault is corrected. Continue normal operations.

END OF TASK

b. CANNON — CONTINUED

(2) EXCESSIVE RECOIL FORCE.

**INITIAL SETUP**

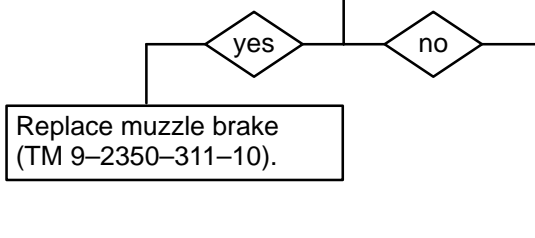
Tools

Artillery and turret mechanic's tool kit  
(SC 5180-95-CL-A12)

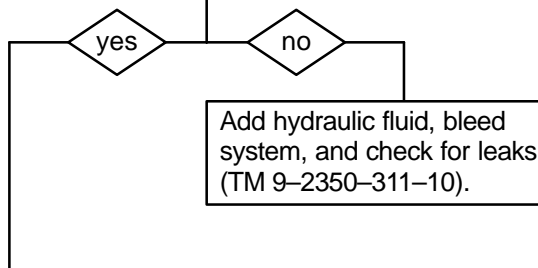
References

TM 9-2350-311-10

**A** 1. Depress cannon assembly to zero mils (TM 9-2350-311-10).  
2. Inspect muzzle brake (para 5-1).  
Is more than a quarter of muzzle brake missing?



**B** Check hydraulic pressure on replenisher pressure gage after mount has cooled (TM 9-2350-311-10).  
Is replenisher pressure 17-24 psi (117.215-165.48 kpa)?



CONTINUED ON NEXT PAGE

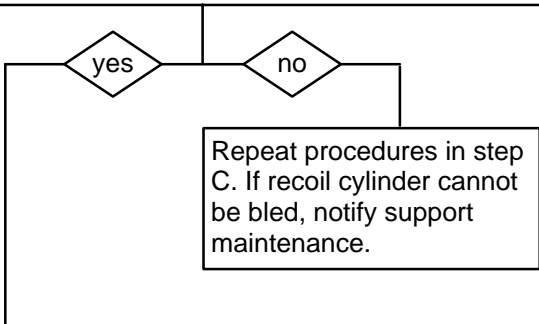
3-3 TROUBLESHOOTING CHART — CONTINUED

b. CANNON — CONTINUED

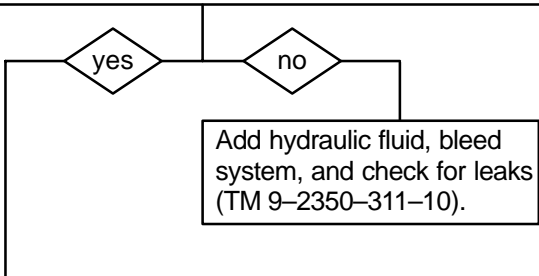
(2) EXCESSIVE RECOIL FORCE. — CONTINUED

CONTINUED FROM STEP B

<b>C</b>	<ol style="list-style-type: none"> <li>1. Using manual elevation handle, depress cannon assembly to maximum depression (TM 9-2350-311-10).</li> <li>2. Loosen right-hand bleed plug and bleed trapped air from rear of buffer. Tighten right-hand bleed plug when air-free fluid flows (TM 9-2350-311-10).</li> <li>3. Using manual elevation handle, elevate cannon assembly to 50 mils (TM 9-2350-311-10).</li> <li>4. Loosen left-bleed plug and bleed trapped air from front of buffer. Tighten left-hand bleed plug when air-free fluid flows (TM 9-2350-311-10).</li> <li>5. Using manual elevation handle, elevate cannon assembly to 180 mils (TM 9-2350-311-10).</li> <li>6. Loosen bleed plug on bleeder tee and bleed trapped air until air-free fluid flows. Tighten bleed plug (TM 9-2350-311-10).</li> </ol>
Does air-free fluid flow?	

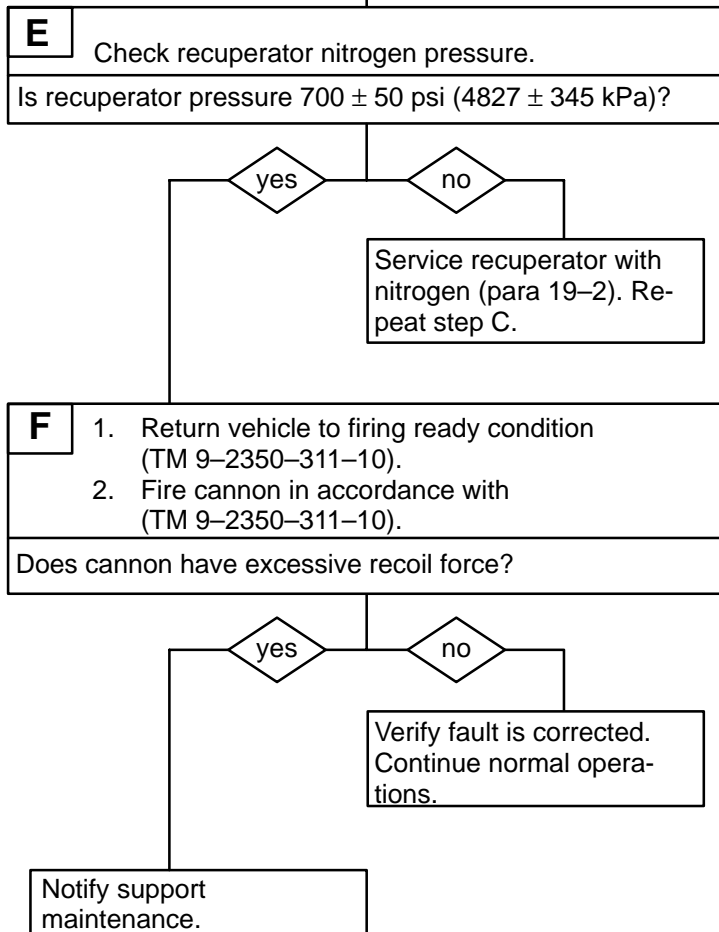


<b>D</b>	Check hydraulic pressure on replenisher pressure gage (TM 9-2350-311-10).
Is replenisher pressure 17-24 psi (117.215-165.48 kpa)?	



CONTINUED ON NEXT PAGE

CONTINUED FROM STEP D



END OF TASK



**3-3 TROUBLESHOOTING CHART — CONTINUED**

b. CANNON — CONTINUED

(3) EXCESSIVE RECOIL TRAVEL AT HIGH ANGLE OF FIRE.

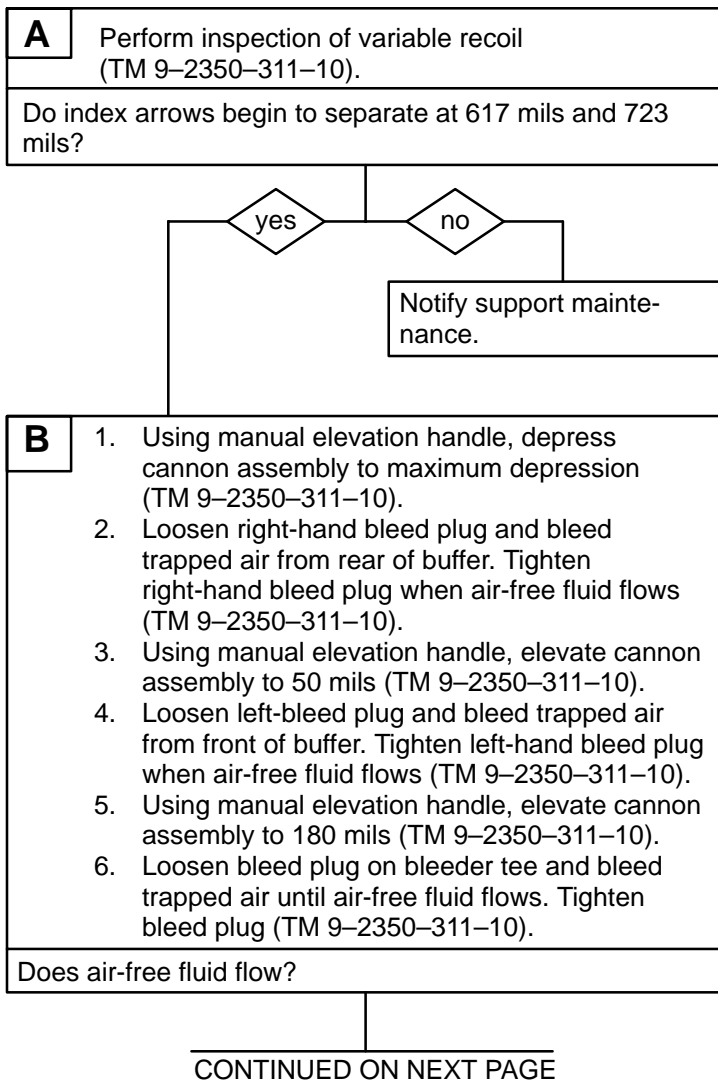
**INITIAL SETUP**

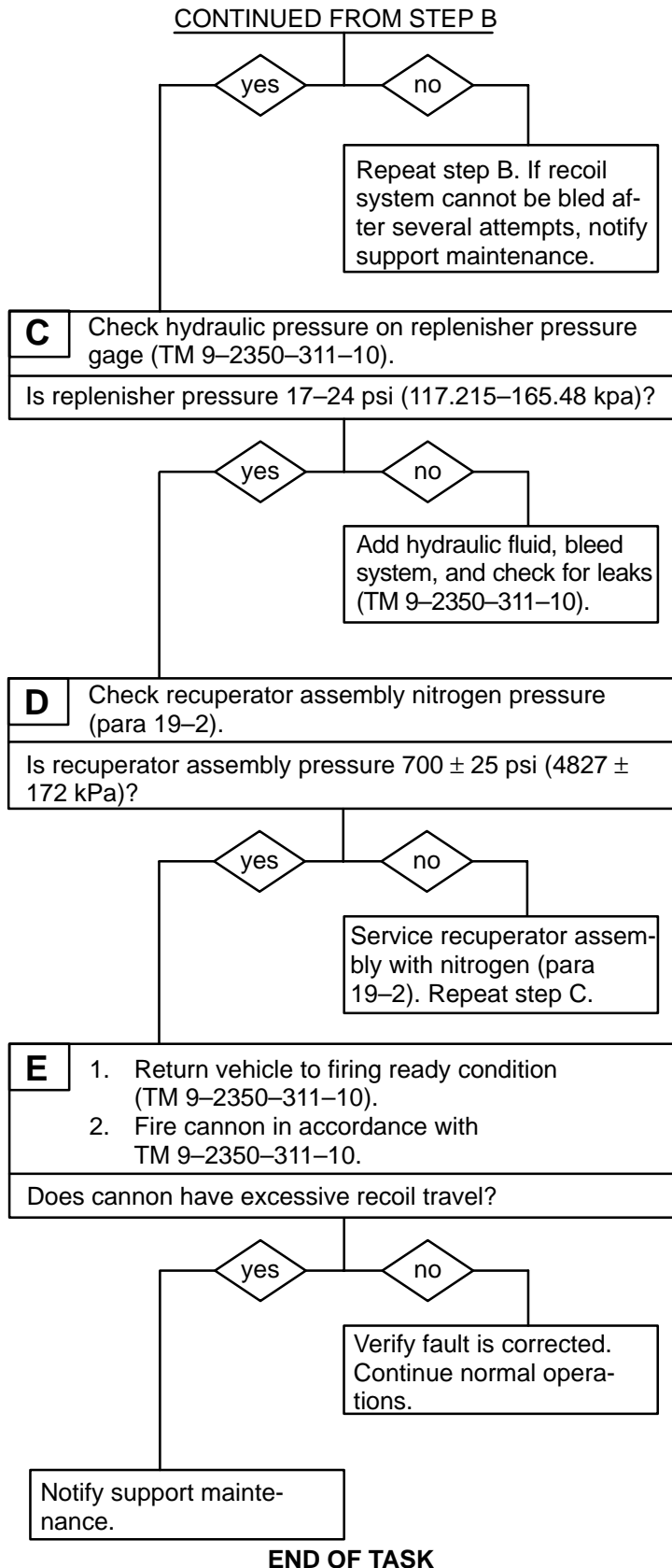
Tools

Artillery and turret mechanic's tool kit  
(SC 5180-95-CL-A12)

References

TM 9-2350-311-10





### 3-3 TROUBLESHOOTING CHART — CONTINUED

b. CANNON — CONTINUED

(4) CANNON DOES NOT RETURN TO BATTERY.

#### INITIAL SETUP

Tools

Artillery and turret mechanic's tool kit

(SC 4933-95-A12)

Hose (item 2.2, Appx H)

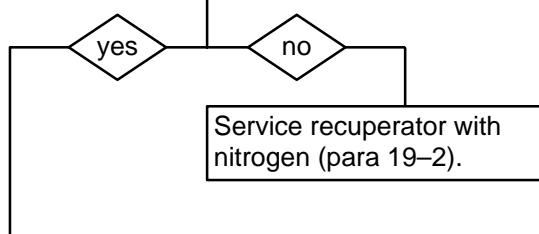
Personnel Required

2

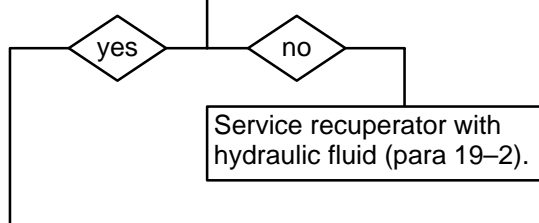
References

TM 9-2350-311-10

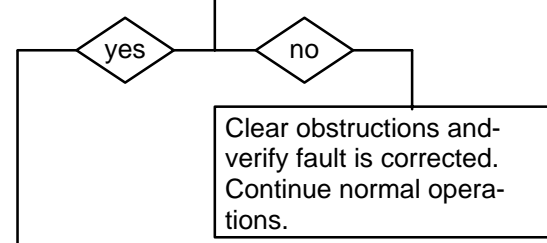
**A** Check recuperator assembly nitrogen pressure (para 19-2).  
 Is recuperator assembly pressure  $700 \pm 25$  psi ( $4827 \pm 172$  kPa)?



**B** Measure recuperator pins (inside and outside) (TM 9-2350-311-10).  
 Do all recuperator pins protrude 1/4 to 3/4 inch (6.35 to 19.05 mm)?



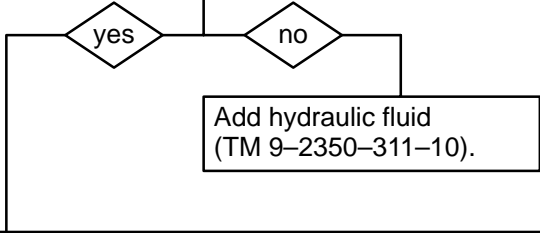
**C** Check cannon for obstructions.  
 Is cannon free from obstructions?



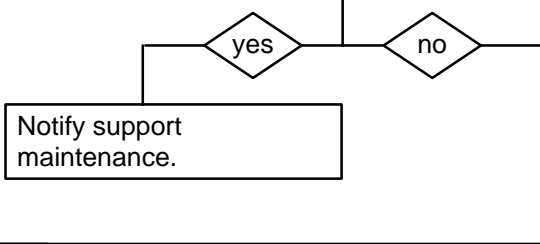
CONTINUED ON NEXT PAGE

CONTINUED FROM STEP C

**D** Check hydraulic pressure on replenisher pressure gage after mount has cooled (TM 9-2350-311-10).  
 Is replenisher pressure 17-24 psi (117.215-165.48 kpa)?



**E** Inspect components that control the recoil and counter recoil operations for bends and gouges.  
 Is recoil and/or counter recoil damaged?



**F**

1. Using manual elevation handle, depress cannon assembly to maximum depression (TM 9-2350-311-10).
2. Loosen right-hand bleed plug and bleed trapped air from rear of buffer. Tighten right-hand bleed plug when air-free fluid flows (TM 9-2350-311-10).
3. Using manual elevation handle, elevate cannon assembly to 50 mils (TM 9-2350-311-10).
4. Loosen left-bleed plug and bleed trapped air from front of buffer. Tighten left-hand bleed plug when air-free fluid flows (TM 9-2350-311-10).
5. Using manual elevation handle, elevate cannon assembly to 180 mils (TM 9-2350-311-10).
6. Loosen bleed plug on bleeder tee and bleed trapped air until air-free fluid flows. Tighten bleed plug (TM 9-2350-311-10).

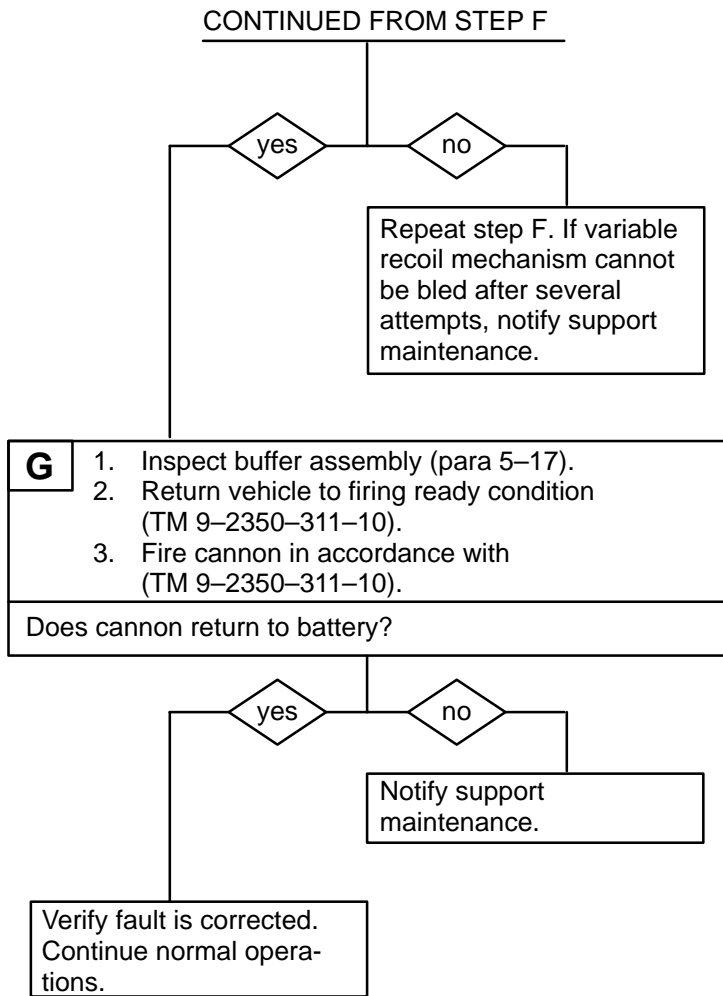
Does air-free fluid flow?

CONTINUED ON NEXT PAGE

3-3 TROUBLESHOOTING CHART — CONTINUED

b. CANNON — CONTINUED

(4) CANNON DOES NOT RETURN TO BATTERY.  
— CONTINUED



END OF TASK

b. CANNON — CONTINUED

(5) PRIMER DOES NOT FIRE.

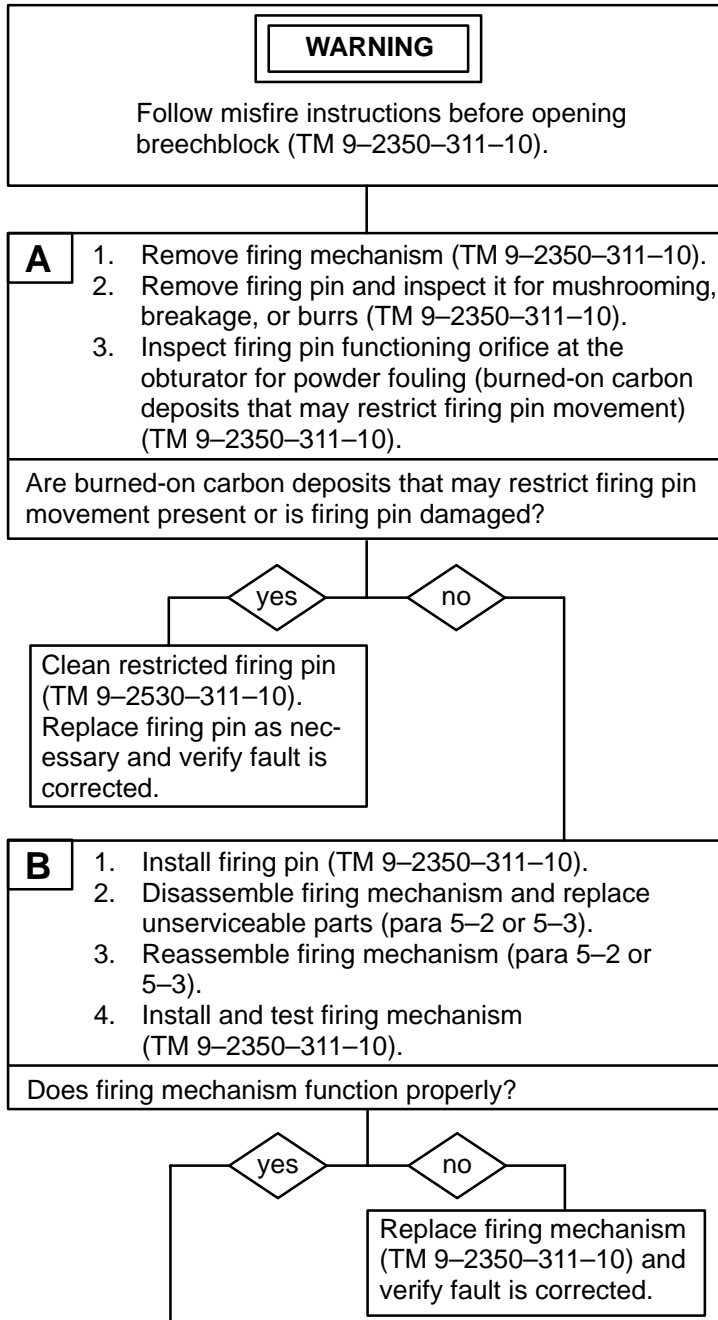
**INITIAL SETUP**

Tools

Artillery and turret mechanic's tool kit  
(SC 5180-95-CL-A12)

References

TM 9-2350-311-10



CONTINUED ON NEXT PAGE

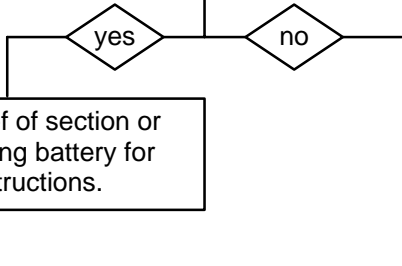
3-3 TROUBLESHOOTING CHART — CONTINUED

b. CANNON — CONTINUED

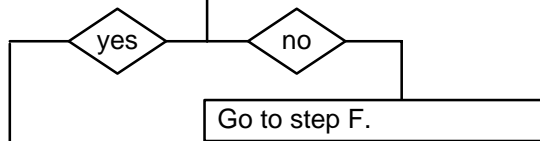
(5) PRIMER DOES NOT FIRE. — CONTINUED

CONTINUED FROM STEP B

**C** Attempt to fire (TM 9-2350-311-10).  
If primer does not fire, is it indented?

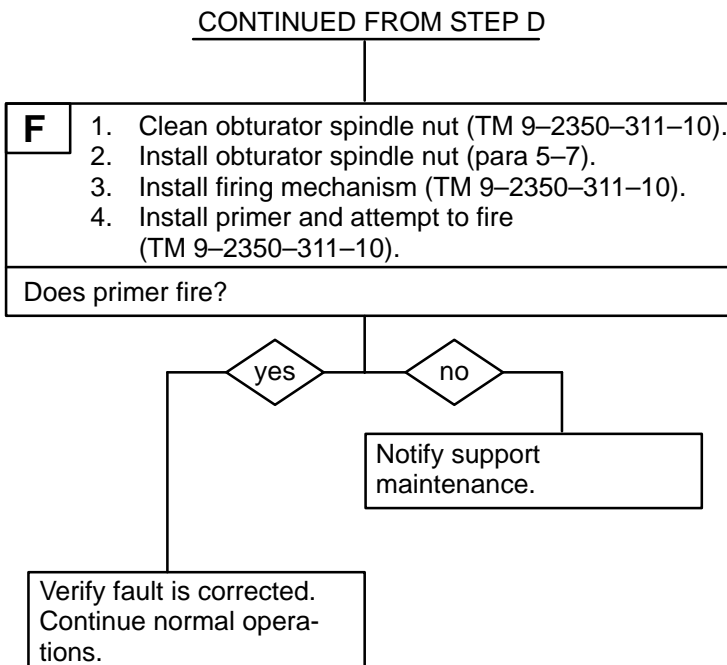
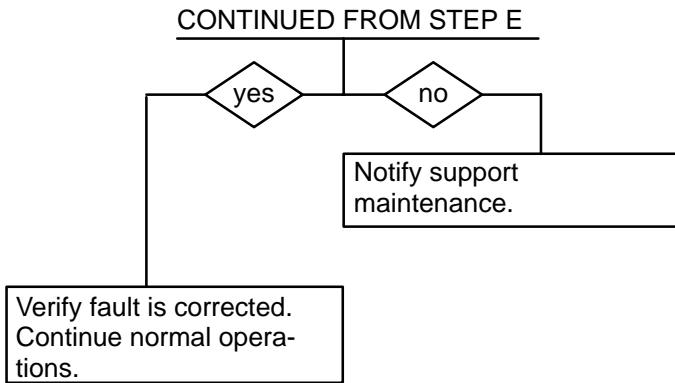


**D** 1. Perform misfire procedures (TM 9-2350-311-10).  
2. Remove firing mechanism (TM 9-2350-311-10).  
3. Remove and check thread inside obturator spindle nut for cross-threading caused by carbon deposits (para 5-7).  
Is obturator spindle nut cross threaded?



**E** 1. Replace obturator spindle nut (para 5-7).  
2. Install firing mechanism (TM 9-2350-311-10).  
3. Attempt to fire (TM 9-2350-311-10).  
Does primer fire?

CONTINUED ON NEXT PAGE



**END OF TASK**



### 3-3 TROUBLESHOOTING CHART — CONTINUED

b. CANNON — CONTINUED

(6) CAB FILLS WITH SMOKE OR GASES AFTER FIRING.

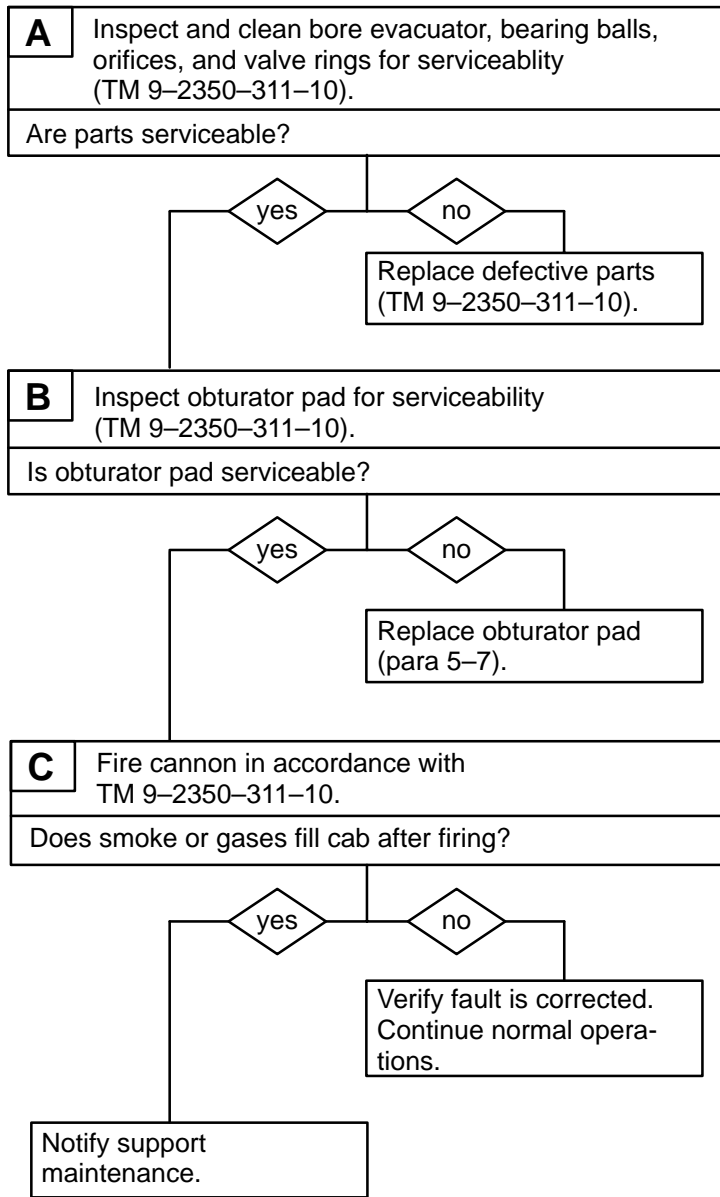
#### INITIAL SETUP

Tools

Artillery and turret mechanic's tool kit  
(SC 5180-95-CL-A12)

References

TM 9-2350-311-10



END OF TASK

c. CAB TRAVERSING SYSTEM

The cab traversing system consists of the gunner's selector switch box assembly, hydraulic motor, bypass valve assembly and solenoid, clutch mechanism, and gunner's control handle. The M109A4/M109A5 howitzers have an additional clutch valve.

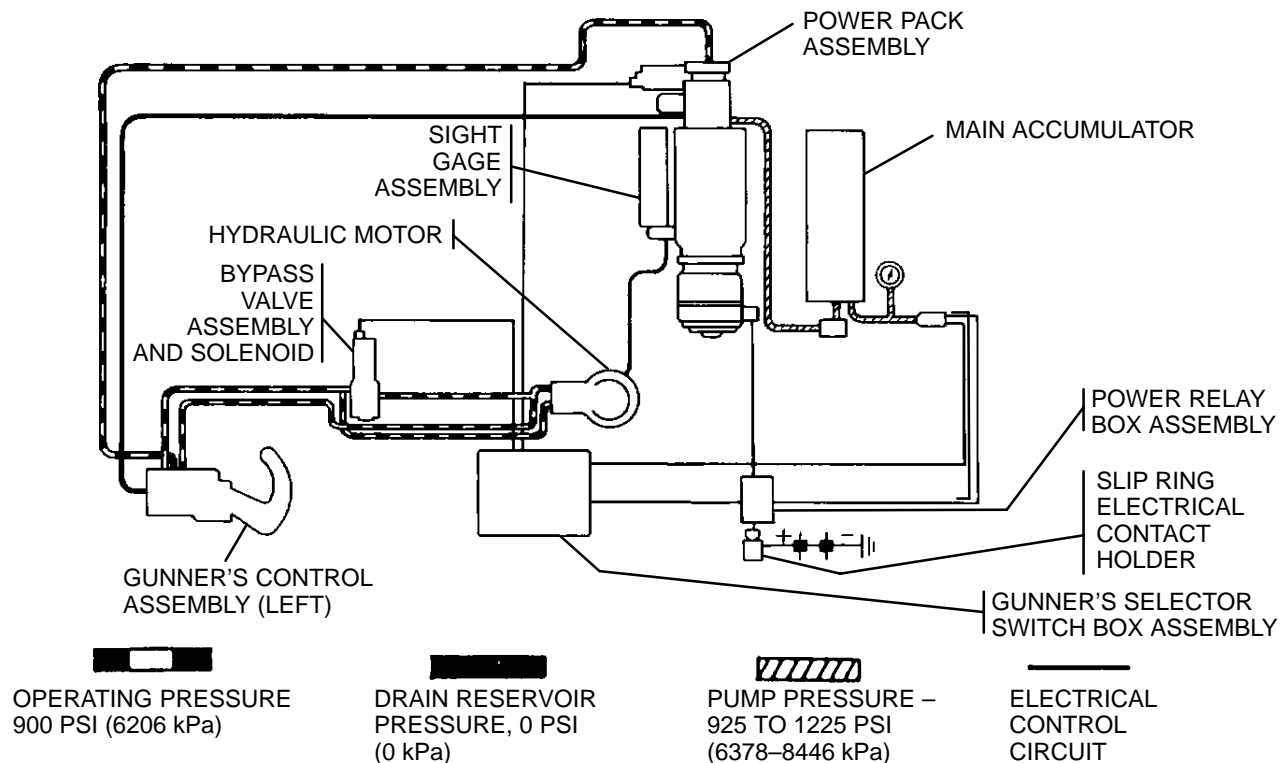
The gunner's selector switch box assembly is used to electrically switch the cab traversing mechanism between power and manual traversing.

The bypass valve assembly and solenoid combination controls the hydraulic power between the manual and power modes. In the power mode, the solenoid will push out the plunger to divert the hydraulic fluid to the hydraulic motor. In the manual mode, the plunger will retract and disengage the hydraulic motor.

The clutch mechanism controls the mechanical switching between the two modes and is controlled electrically (M109A2/M109A3 howitzers) or hydraulically (M109A4/M109A5 howitzers). The clutch valve in the M109A4/M109A5 howitzers controls the flow to the clutch.

The gunner's control handle operates the power traversing of the cab and the manual traverse handwheel operates the manual traversing of the cab.

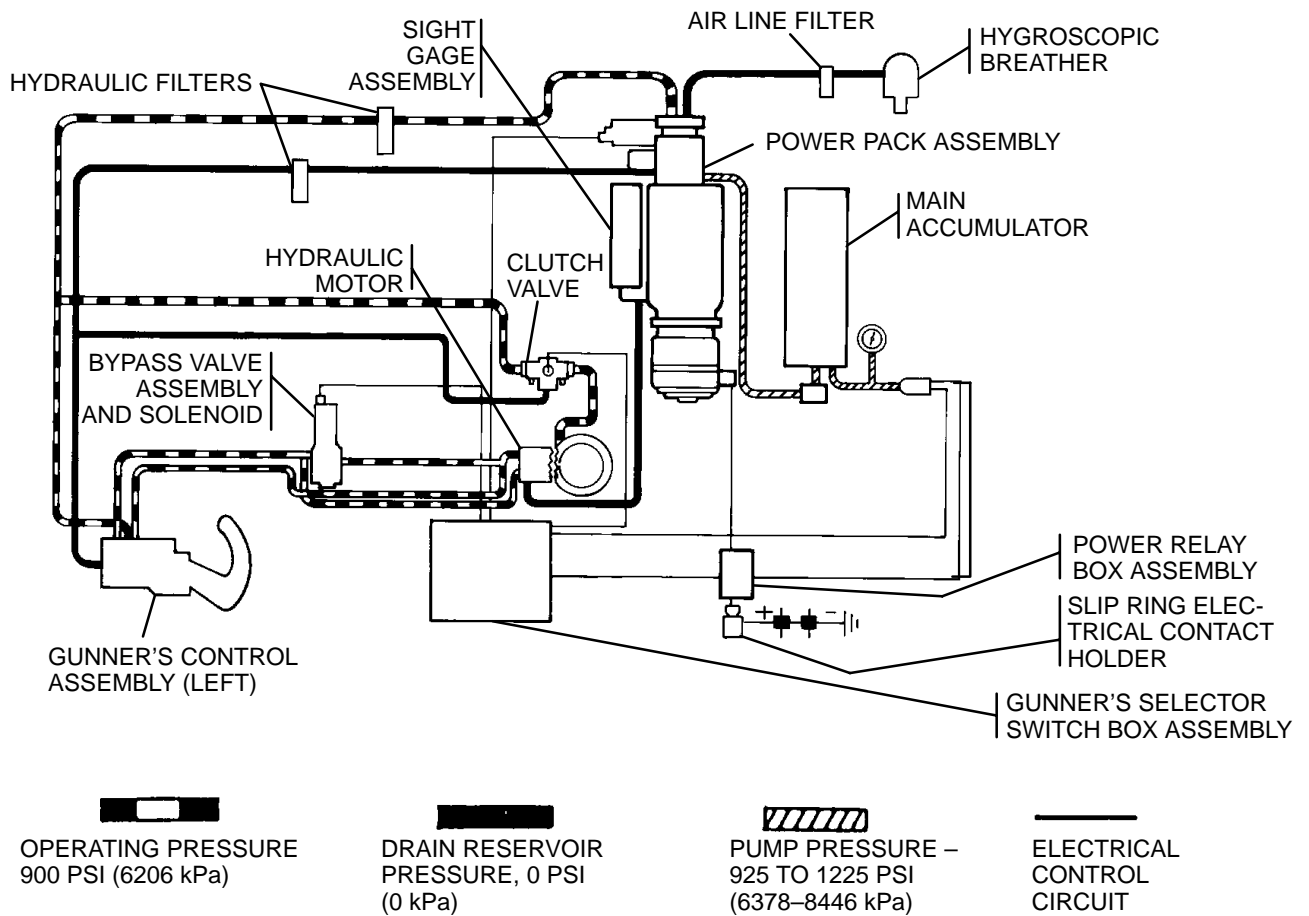
CAB TRAVERSING SYSTEM (M109A2/M109A3 HOWITZERS)



3-3 TROUBLESHOOTING CHART — CONTINUED

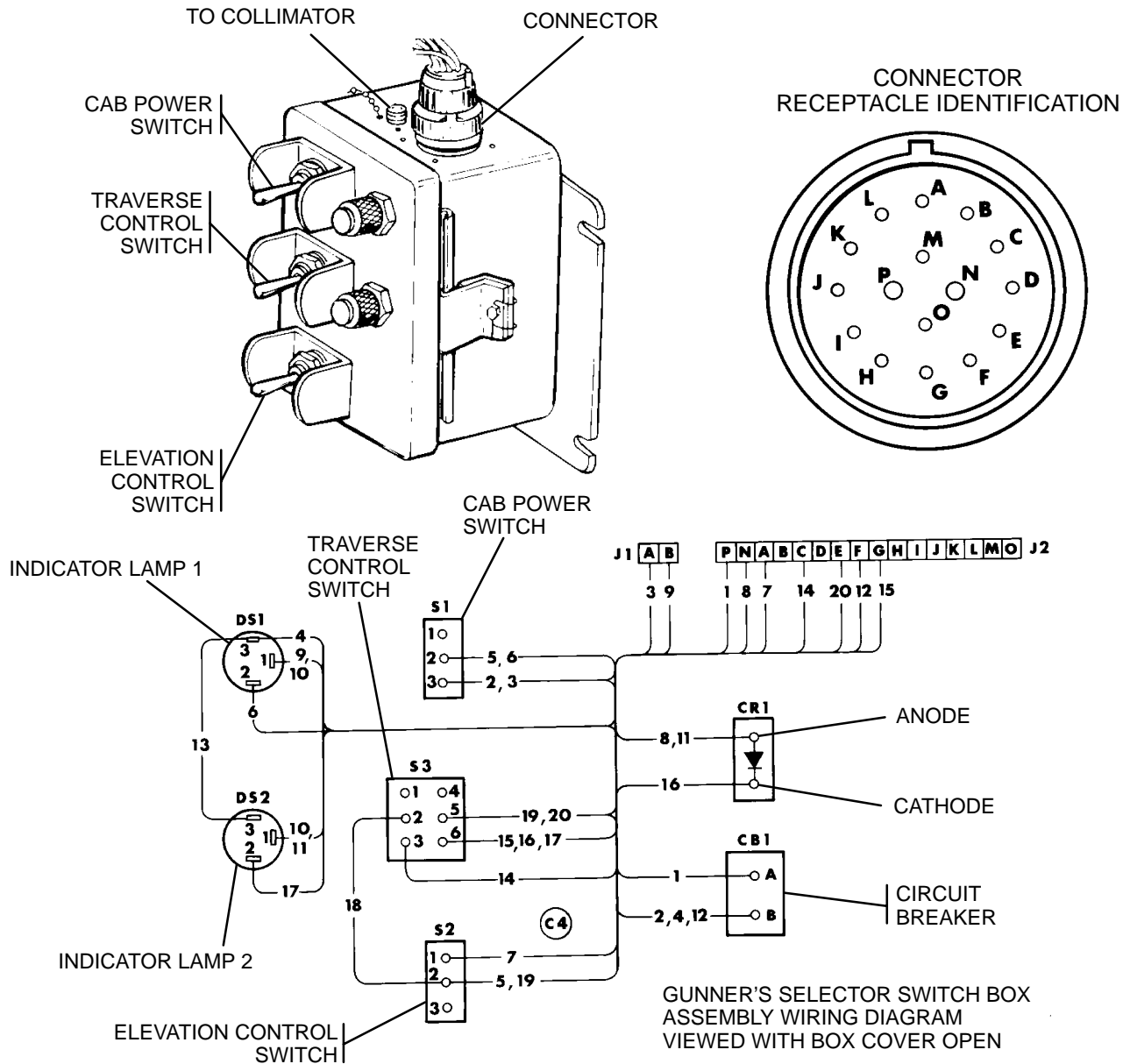
c. CAB TRAVERSING SYSTEM — CONTINUED

CAB TRAVERSING SYSTEM (M109A4/M109A5 HOWITZERS)



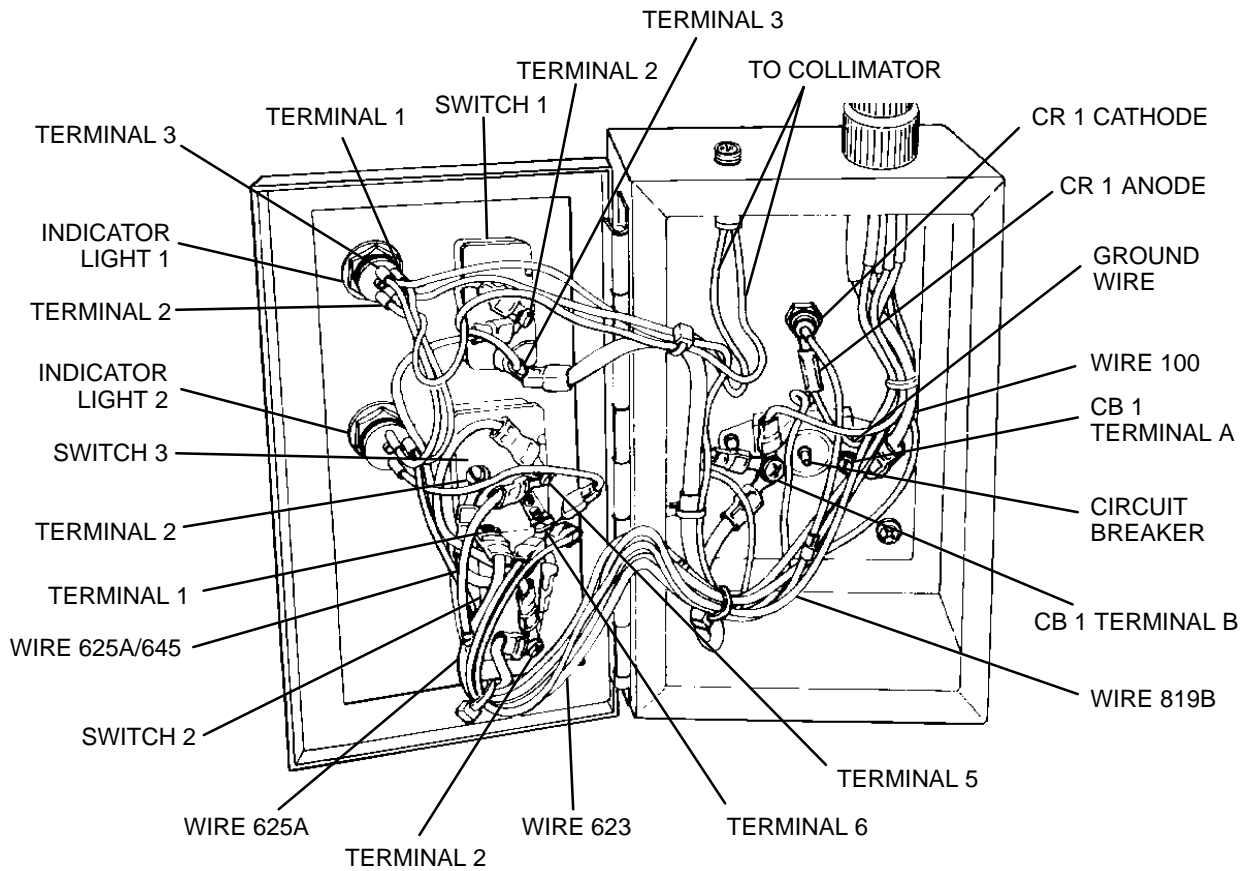
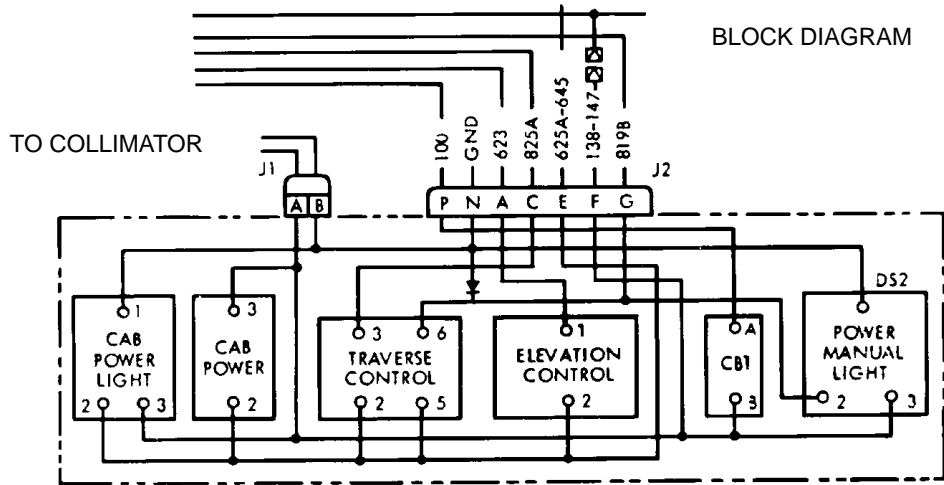
**NOTE**

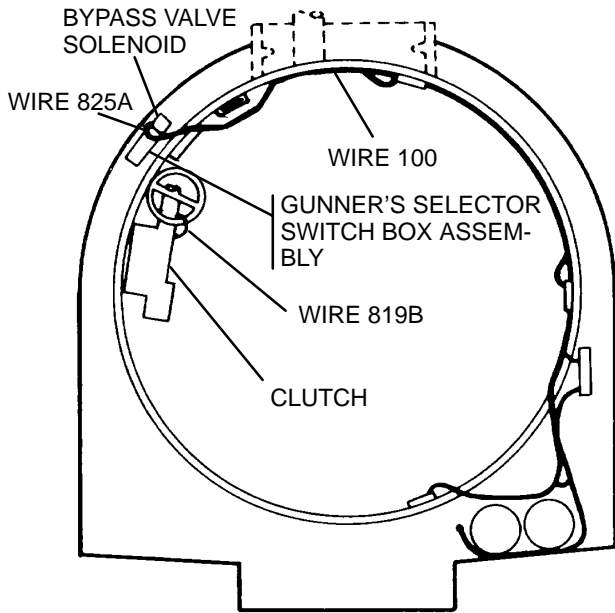
The following illustrates: terminal locations on lamps and switches, semiconductor, and circuit breakers; connector receptacles; and general electrical layout of gunner's selector switch box assembly. Refer to these diagrams to locate multimeter probes when performing troubleshooting steps.



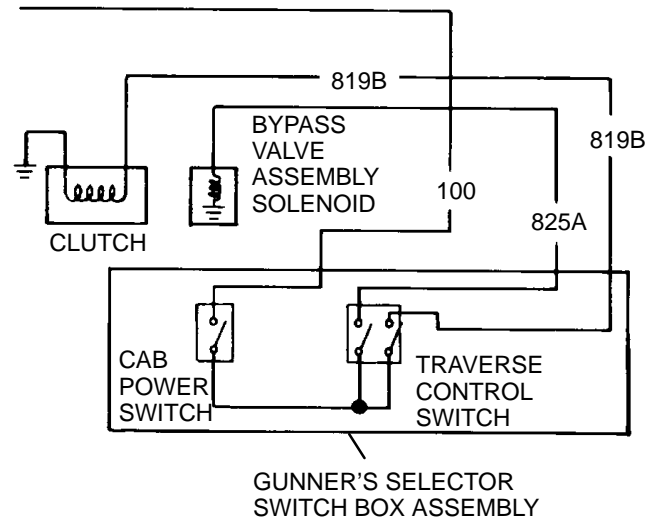
3-3 TROUBLESHOOTING CHART — CONTINUED

c. CAB TRAVERSING SYSTEM — CONTINUED



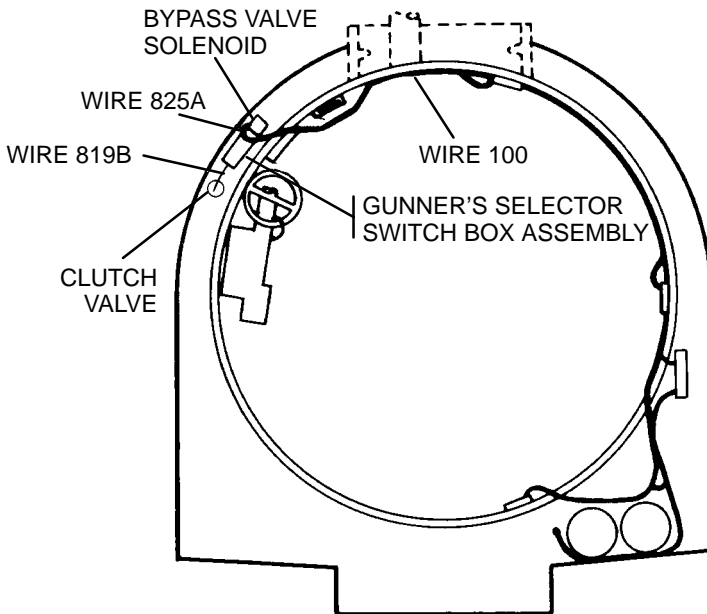


PICTORIAL VIEW

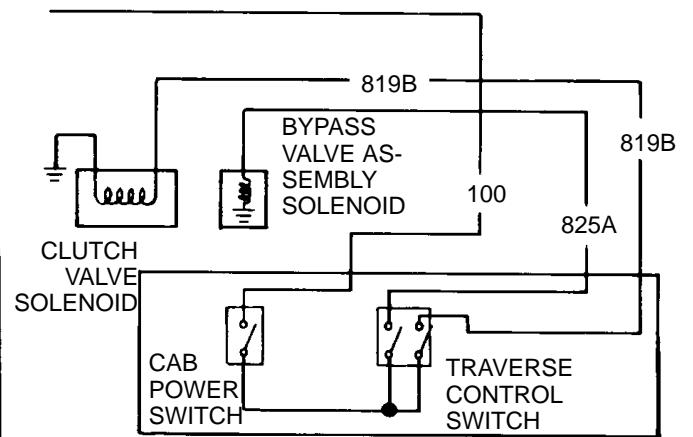


ELECTRICAL DIAGRAM

CAB TRAVERSING SYSTEM (M109A2/M109A3 HOWITZERS)



PICTORIAL VIEW



ELECTRICAL DIAGRAM

CAB TRAVERSING SYSTEM (M109A4/M109A5 HOWITZERS)

### 3-3 TROUBLESHOOTING CHART — CONTINUED

c. CAB TRAVERSING SYSTEM — CONTINUED

(1) CAB WILL NOT TRAVERSE UNDER POWER OR MANUALLY, BUT HYDRAULIC PRESSURE IS NORMAL AND CAB LIGHTING OPERATES.

#### INITIAL SETUP

Test Equipment

Multimeter (item 6, Appx H)

Tools

Artillery and turret mechanic's tool kit  
(SC 5180-95-CL-A12)

References

TM 9-2350-311-10

Equipment Condition

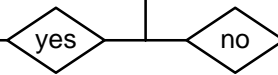
Vehicle MASTER switch to ON (TM 9-2350-311-10)

CAB POWER switch to ON (TM 9-2350-311-10)

TRAVERSE CONTROL switch to POWER

(TM 9-2350-311-10)

**A** Check for cant in excess of 89 mils (TM 9-2350-311-10). Level vehicle if necessary.  
Does cab traverse under power?



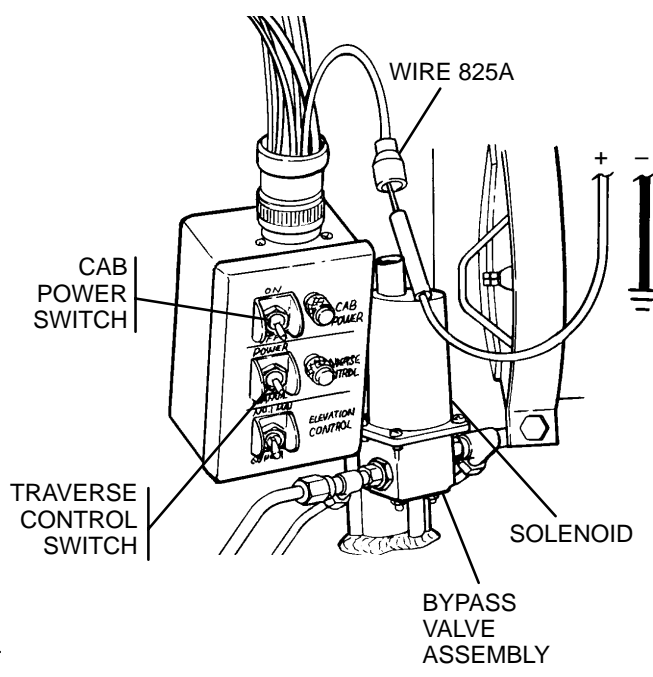
Continue normal operations.

**B** 1. Turn MASTER and CAB POWER switches to OFF.  
2. Disconnect wire 825A from bypass valve assembly solenoid.  
3. Turn MASTER and CAB POWER switches to ON.  
4. Ensure TRAVERSE CONTROL switch is in POWER position.  
5. Place red multimeter lead in wire 825A and black lead to ground.  
6. Check for voltage.

Is battery voltage present?



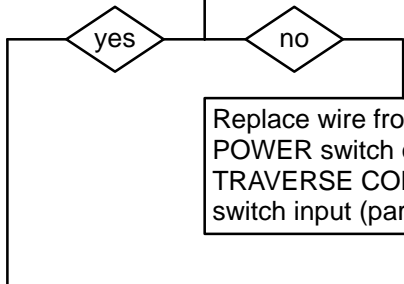
Go to step F.



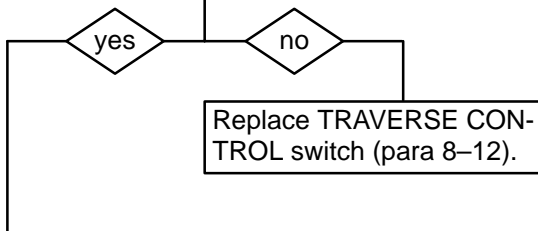
CONTINUED ON NEXT PAGE

CONTINUED FROM STEP B

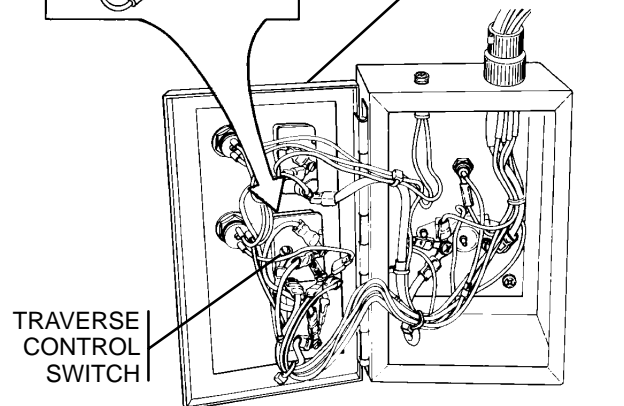
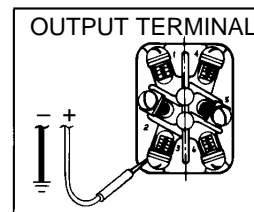
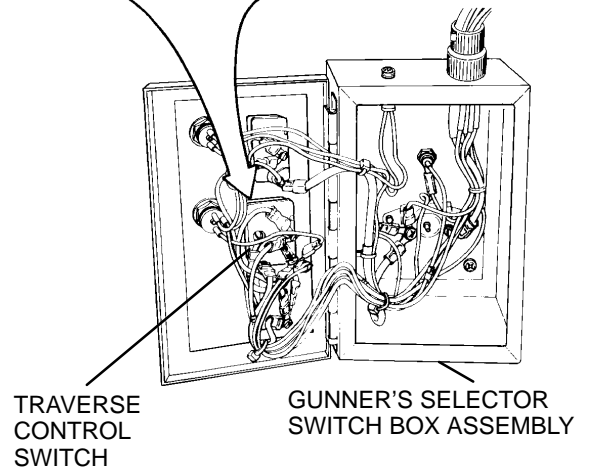
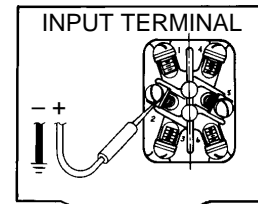
- C**
1. Turn MASTER and CAB POWER switches to OFF.
  2. Open gunner's selector switch box assembly.
  3. Turn MASTER and CAB POWER switches to ON.
  4. Place red multimeter lead on input terminal 2 of TRAVERSE CONTROL switch and black lead to ground.
  5. Check for voltage.
- Is battery voltage present?



- D**
1. Place red multimeter lead on output terminal 3 of TRAVERSE CONTROL switch and black lead to ground.
  2. Check for voltage.
- Is battery voltage present?



CONTINUED ON NEXT PAGE





3-3 TROUBLESHOOTING CHART — CONTINUED

c. CAB TRAVERSING SYSTEM — CONTINUED

(1) CAB WILL NOT TRAVERSE UNDER POWER OR MANUALLY, BUT HYDRAULIC PRESSURE IS NORMAL AND CAB LIGHTING OPERATES.— CONTINUED

CONTINUED FROM STEP D

**E** 1. Turn MASTER and CAB POWER switches to OFF.  
 2. Disconnect harness from J2 connector at gunner's selector switch box assembly.  
 3. Place one multimeter lead on output terminal 3 of TRAVERSE CONTROL switch and the other lead to pin C of J2 connector.  
 4. Check for continuity.

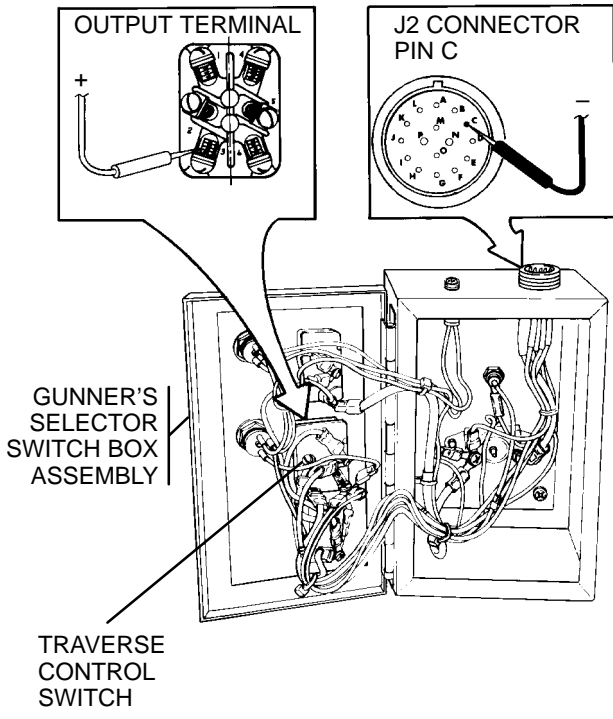
Is continuity present?

yes

no

Replace wire from TRAVERSE CONTROL switch to pin C of J2 connector (para 8-12).

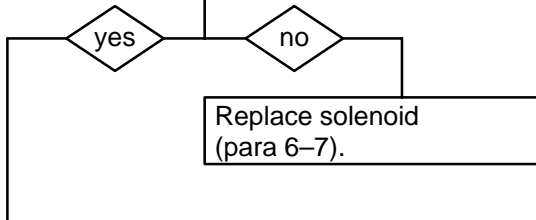
Replace wire 825A from gunner's selector switch box assembly to bypass valve assembly (para 8-7).



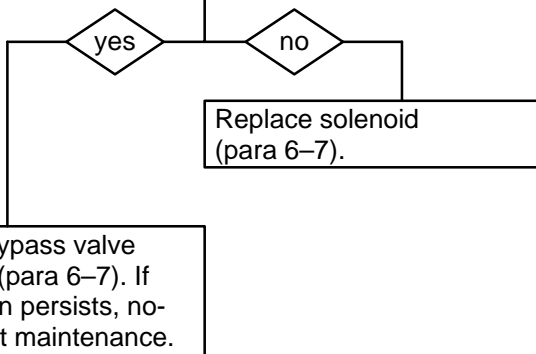
CONTINUED ON NEXT PAGE

CONTINUED FROM STEP B

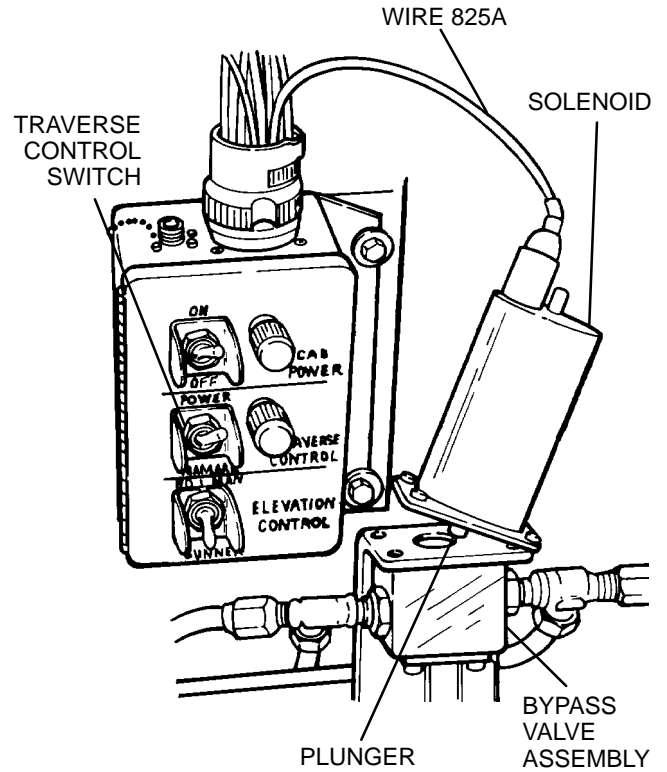
- F**
1. Turn MASTER and CAB POWER switches to OFF.
  2. Discharge hydraulic pressure (para 6-3). Do not reconnect wire 645 at pressure switch.
  3. Remove solenoid from bypass valve assembly (para 6-7).
  4. Reconnect wire 825A to solenoid and ground edge of solenoid to valve body.
  5. Turn MASTER and CAB POWER switches to ON.
  6. Ensure TRAVERSE CONTROL switch is in POWER position.
- Does plunger protrude from bottom of solenoid?



- G**
1. Place TRAVERSE CONTROL switch in MANUAL position.
  2. Apply a small amount of pressure to plunger.
- Does plunger retract?



END OF TASK



3-3 TROUBLESHOOTING CHART — CONTINUED

c. CAB TRAVERSING SYSTEM — CONTINUED

(2) MANUAL TRAVERSE HANDWHEEL ROTATES WHILE TRAVERSING IN POWER.

**INITIAL SETUP**

Test Equipment

Multimeter (item 6, Appx H)

Tools

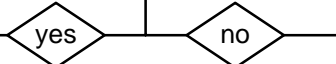
Artillery and turret mechanic's tool kit  
(SC 5180-95-CL-A12)

Equipment Condition

Vehicle MASTER switch to OFF (TM 9-2350-311-10)  
CAB POWER switch to OFF (TM 9-2350-311-10)

- A**
1. Disconnect wire 819B at electric clutch housing (M109A2/M109A3 howitzers) or clutch valve (M109A4/M109A5 howitzers).
  2. Turn MASTER and CAB POWER switches to ON and the TRAVERSE CONTROL switch to power.
  3. Place red multimeter lead in wire 819B and black lead to ground.
  4. Check for voltage.

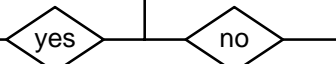
Is battery voltage present?



Go to step E for M109A2/M109A3 howitzers or step F for M109A4/M109A5 howitzers.

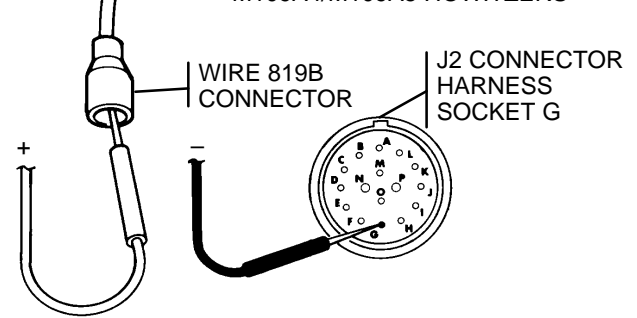
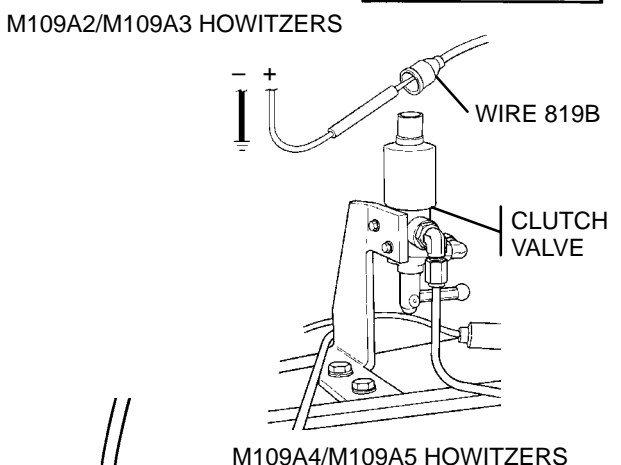
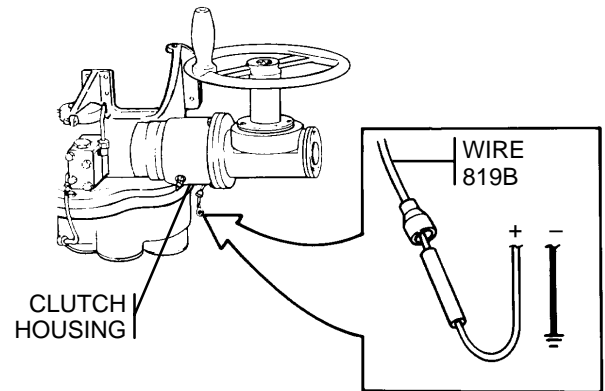
- B**
1. Turn MASTER and CAB POWER switches to OFF.
  2. Disconnect harness from J2 connector at gunner's selector switch box assembly.
  3. Place one multimeter lead in wire 819B connector and other lead to socket G of J2 connector harness.
  4. Check for continuity.

Is continuity present?



Replace wire 819B (para 8-7).

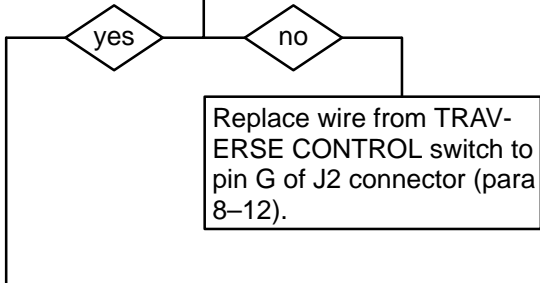
CONTINUED ON NEXT PAGE



CONTINUED FROM STEP B

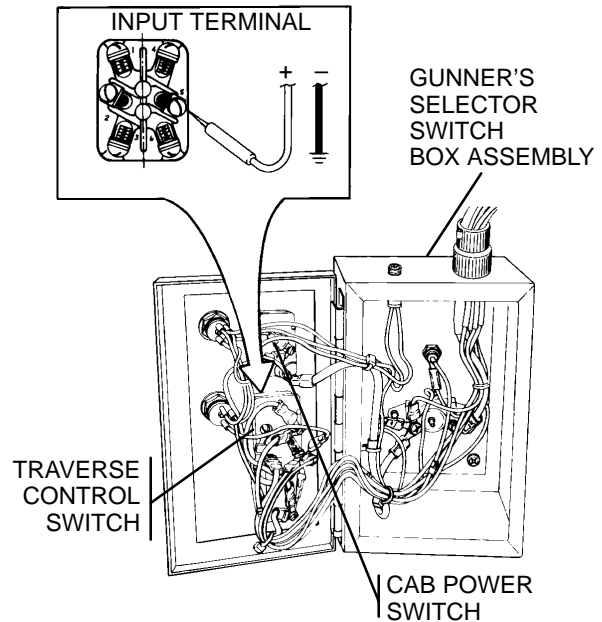
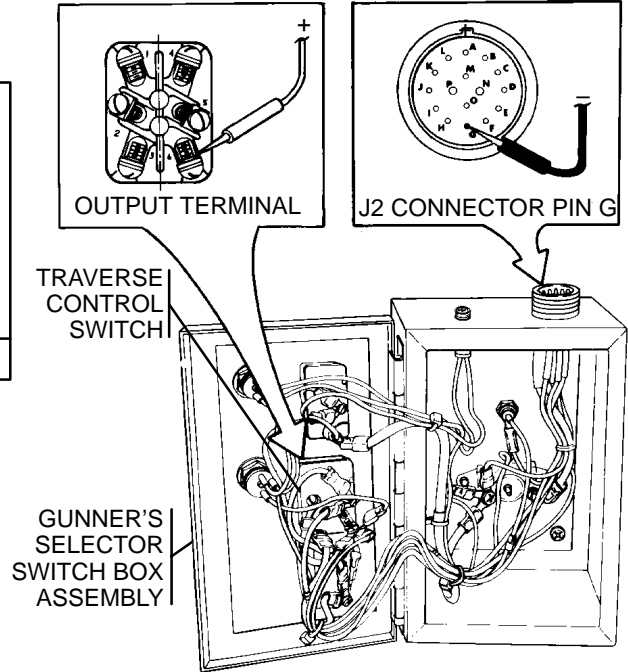
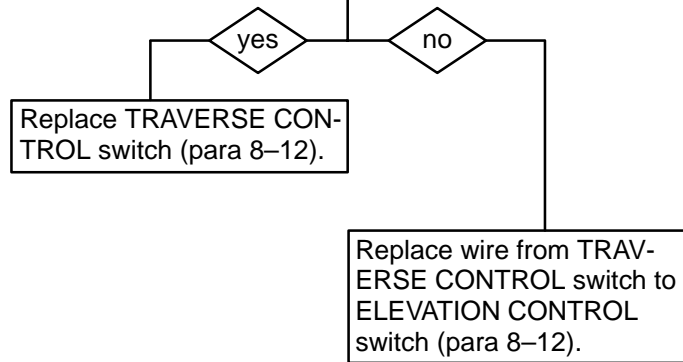
- C**
1. Reconnect wire 819B at electric clutch housing (M109A2/M109A3 howitzers) or clutch valve (M109A4/M109A5 howitzers).
  2. Open gunner's selector switch box assembly.
  3. Place one multimeter lead at TRAVERSE CONTROL switch output terminal 6 and other lead to pin G of J2 connector.
  4. Check for continuity.

Is continuity present?



- D**
1. Reconnect harness at J2 connector of gunner's selector switch box assembly.
  2. Turn MASTER and CAB POWER switches to ON.
  3. Place red multimeter lead at TRAVERSE CONTROL switch input terminal 5 and black lead to ground.
  4. Check for voltage.

Is battery voltage present?



CONTINUED ON NEXT PAGE

3-3 TROUBLESHOOTING CHART — CONTINUED

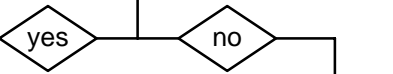
c. CAB TRAVERSING SYSTEM — CONTINUED

(2) MANUAL TRAVERSE HANDWHEEL ROTATES WHILE TRAVERSING IN POWER. — CONTINUED

CONTINUED FROM STEP A

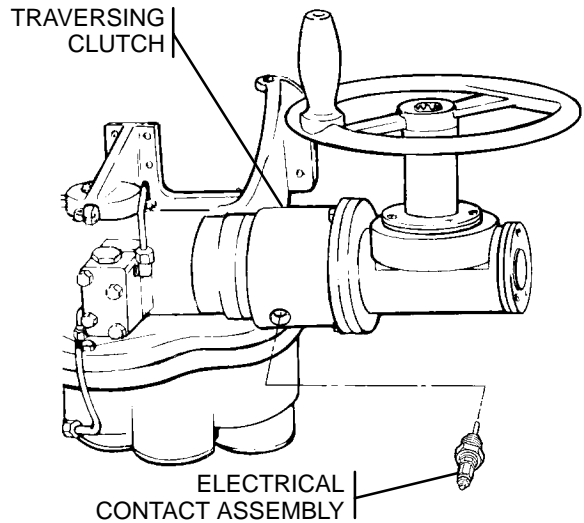
**E** 1. Turn MASTER and CAB POWER switches to OFF.  
 2. Remove and inspect traversing clutch electrical contact assembly (M109A2/M109A3 howitzers) for wear or damage.

Is contact defective?



Notify support maintenance.

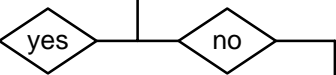
Replace electrical contact assembly (para 11-3).



CONTINUED FROM STEP A

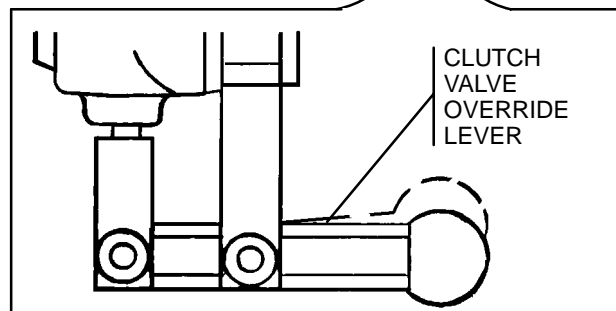
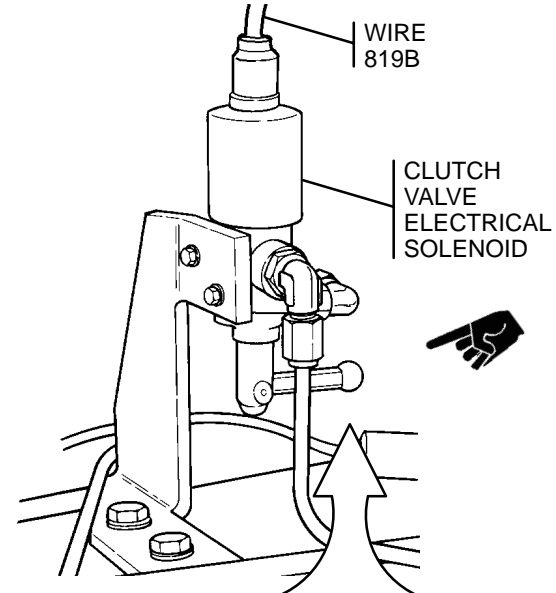
**F** 1. Turn MASTER and CAB POWER switches to OFF.  
 2. Reconnect wire 819B to clutch valve electrical solenoid.  
 3. Turn Vehicle MASTER switch to ON.  
 4. Turn CAB POWER switch to ON.

Does the clutch valve override lever move?



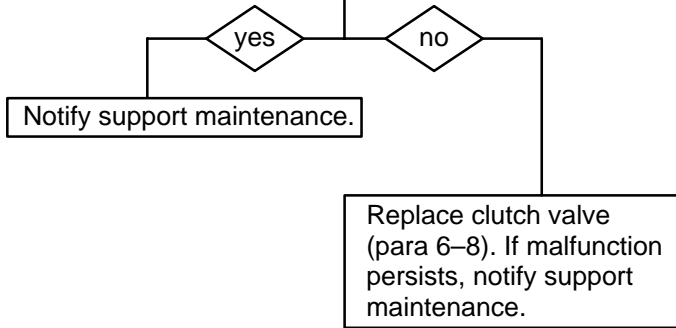
CONTINUED ON NEXT PAGE

Replace clutch valve electrical solenoid (para 6-8).

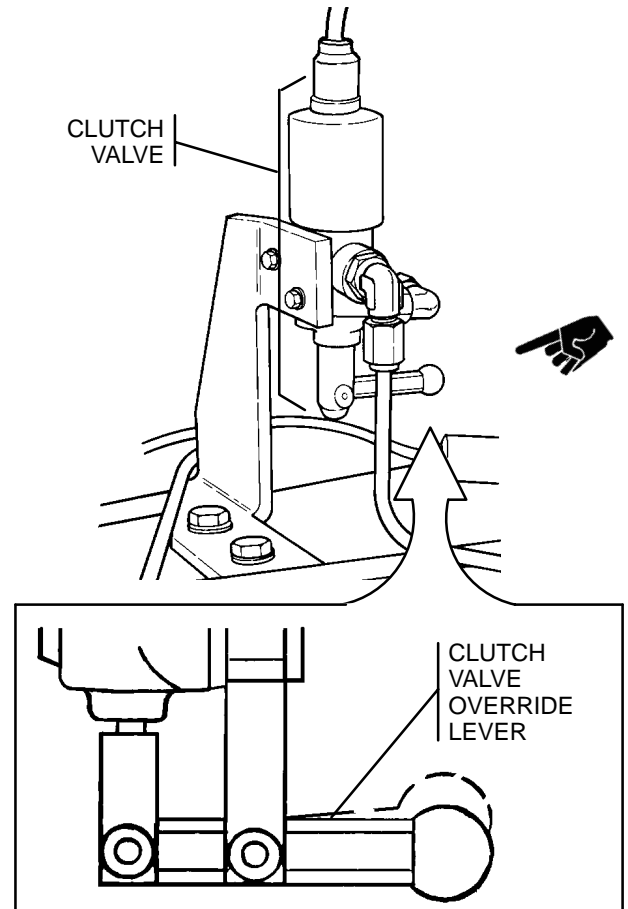


CONTINUED FROM STEP F

**G** Traverse cab while pulling up on clutch valve override lever.  
Does manual traverse handwheel turn during power traversing?



END OF TASK



### 3-3 TROUBLESHOOTING CHART — CONTINUED

c. CAB TRAVERSING SYSTEM — CONTINUED

(2.1) CAB WILL NOT TRAVERSE UNDER POWER, MANUAL OPERATION IS NORMAL.

#### INITIAL SETUP

Applicable Configuration  
M109A4/M109A5 howitzer

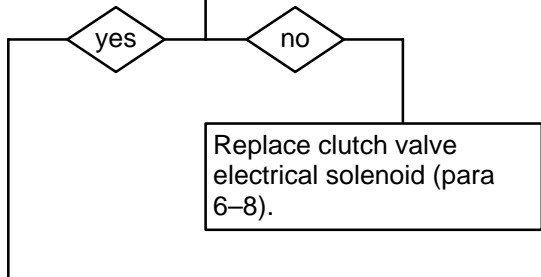
Tools  
Artillery and turret mechanic's tool kit  
(SC 5180-95-CL-A12)

Equipment Condition

Vehicle MASTER switch to OFF (TM 9-2350-311-10)  
CAB POWER switch to OFF (TM 9-2350-311-10)  
TRAVERSE CONTROL switch to POWER  
(TM 9-2350-311-10)

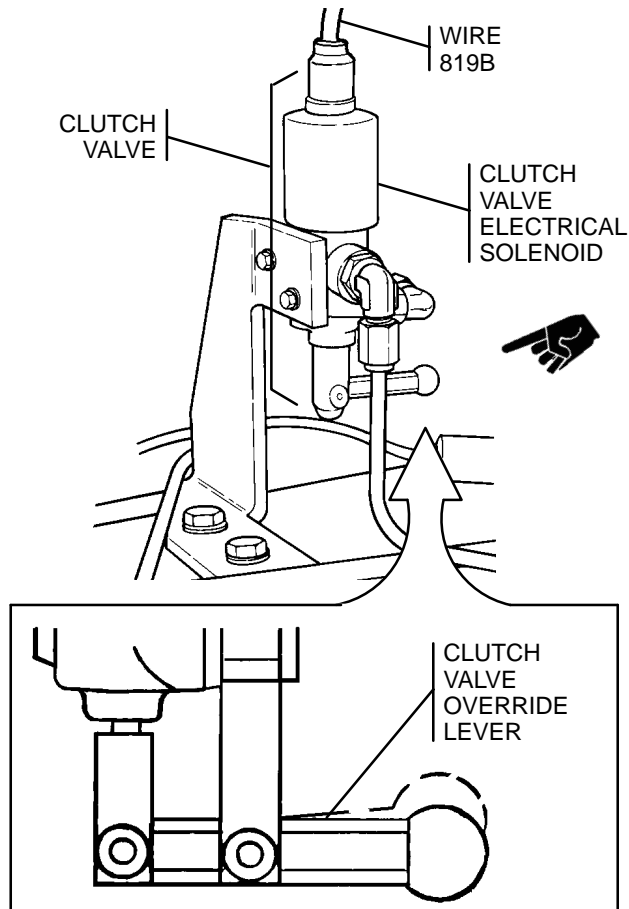
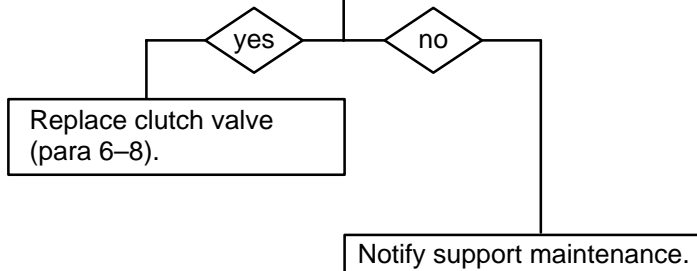
**A** 1. Check to ensure wire 819B to clutch valve electrical solenoid is connected.  
2. Turn MASTER switch to ON.  
3. Turn CAB POWER switch to ON.

Does the clutch valve override lever move?



**B** Traverse cab while pulling up on clutch valve override lever.

Does the cab traverse under power?



c. CAB TRAVERSING SYSTEM — CONTINUED

(3) CAB TRAVERSES UNDER POWER, BUT TRAVERSE CONTROL INDICATOR LAMP DOES NOT LIGHT.

**INITIAL SETUP**

Test Equipment

Multimeter (item 6, Appx H)

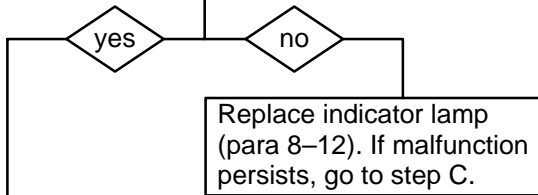
Tools

Artillery and turret mechanic's tool kit  
(SC 5180-95-CL-A12)

Equipment Condition

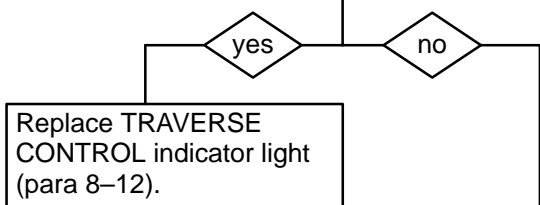
Vehicle MASTER switch to ON (TM 9-2350-311-10)  
CAB POWER switch to ON (TM 9-2350-311-10)

**A** Push "press to test" TRAVERSE CONTROL indicator light.  
Does indicator light illuminate?

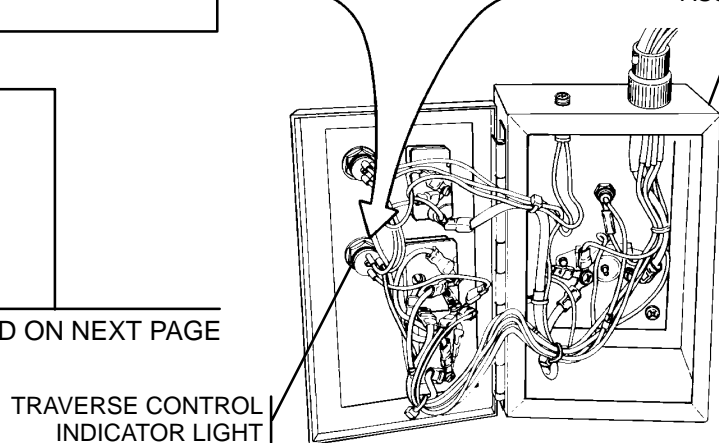
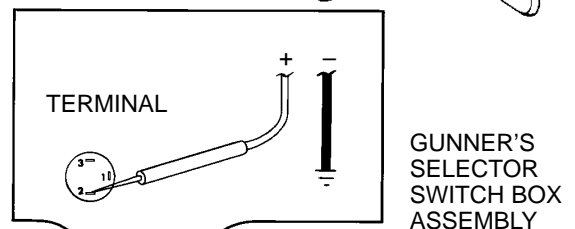
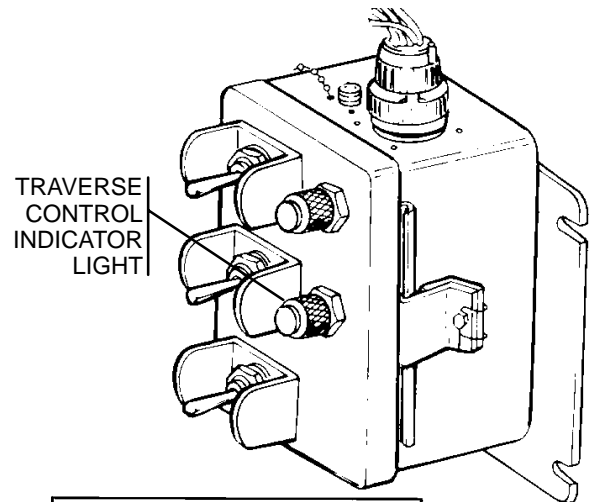


**B** 1. Turn MASTER and CAB POWER switches to OFF.  
2. Open gunner's selector switch box assembly.  
3. Turn CAB POWER, MASTER, and TRAVERSE CONTROL switches to ON.  
4. Place red multimeter lead on terminal 2 of TRAVERSE CONTROL indicator light and black lead to ground.  
5. Check for voltage.

Is battery voltage present?



CONTINUED ON NEXT PAGE





3-3 TROUBLESHOOTING CHART — CONTINUED

c. CAB TRAVERSING SYSTEM — CONTINUED

(3) CAB TRAVERSES UNDER POWER, BUT TRAVERSE CONTROL INDICATOR LAMP DOES NOT LIGHT. — CONTINUED

CONTINUED FROM STEP A OR B

- C**
1. Turn CAB POWER, MASTER, and TRAVERSE CONTROL switches to OFF.
  2. If necessary, open gunner's selector switch box assembly.
  3. Place one multimeter lead on terminal 1 of TRAVERSE CONTROL indicator light and other lead to ground.
  4. Check for continuity.
- Is continuity present?

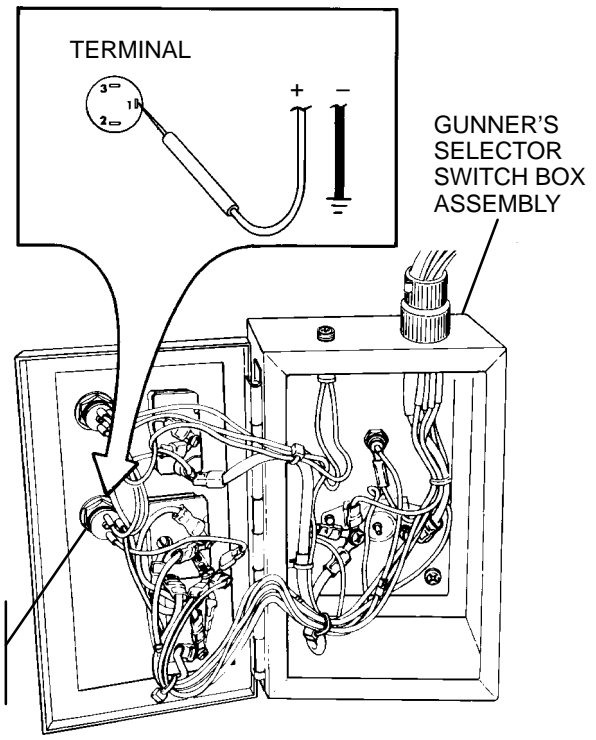
yes

no

Repair ground circuit from terminal 1 of TRAVERSE CONTROL indicator light (para 8-12).

Replace TRAVERSE CONTROL indicator light (para 8-12).

END OF TASK



c. CAB TRAVERSING SYSTEM — CONTINUED

(4) CAB WILL NOT TRAVERSE FREELY IN MANUAL OR POWER MODES.

**INITIAL SETUP**

Tools

Artillery and turret mechanic's tool kit  
(SC 5180-95-CL-A12)

CAB POWER switch to OFF (TM 9-2350-311-10)  
TRAVERSE CONTROL switch in MANUAL position  
(TM 9-2350-311-10)

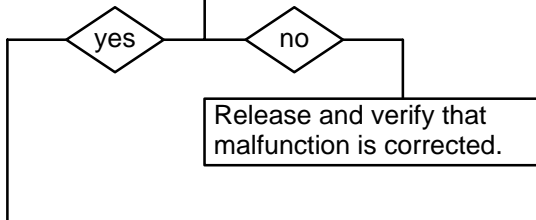
Equipment Condition

Vehicle MASTER switch to OFF (TM 9-2350-311-10)

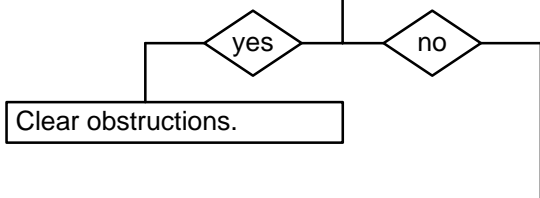
**NOTE**

All attempts to traverse should be made manually only.

**A** Check cannon travel lock and traverse lock.  
Are cannon travel lock and traverse lock fully released?



**B** 1. Check vehicle interior and exterior for obstructions that may impede traversing.  
2. Check for dirt, rust, or other obstructions on main drive gears or cab ring gear.  
Are obstructions present?



CONTINUED ON NEXT PAGE

---

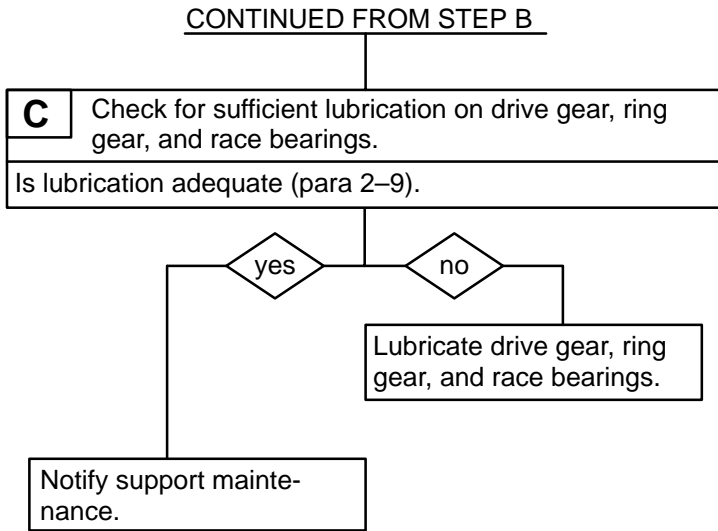
### 3-3 TROUBLESHOOTING CHART — CONTINUED

---

c. CAB TRAVERSING SYSTEM — CONTINUED

(4) CAB WILL NOT TRAVERSE FREELY IN MANUAL OR POWER MODES. — CONTINUED

---



**END OF TASK**

c. CAB TRAVERSING SYSTEM — CONTINUED

(5) CAB CREEPS.

**INITIAL SETUP**

Tools

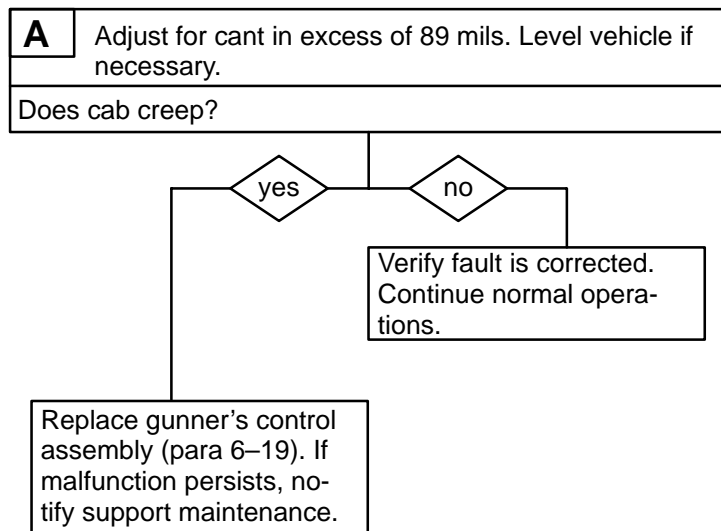
Artillery and turret mechanic's tool kit  
(SC 5180-95-CL-A12)

CAB POWER switch to ON (TM 9-2350-311-10)

TRAVERSE CONTROL switch in POWER position  
(TM 9-2350-311-10)

Equipment Condition

Vehicle MASTER switch to ON (TM 9-2350-311-10)



**END OF TASK**

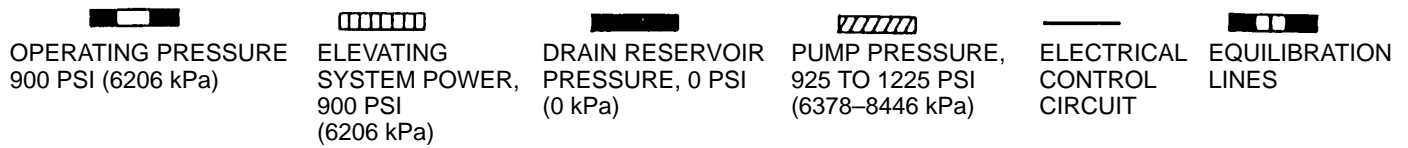
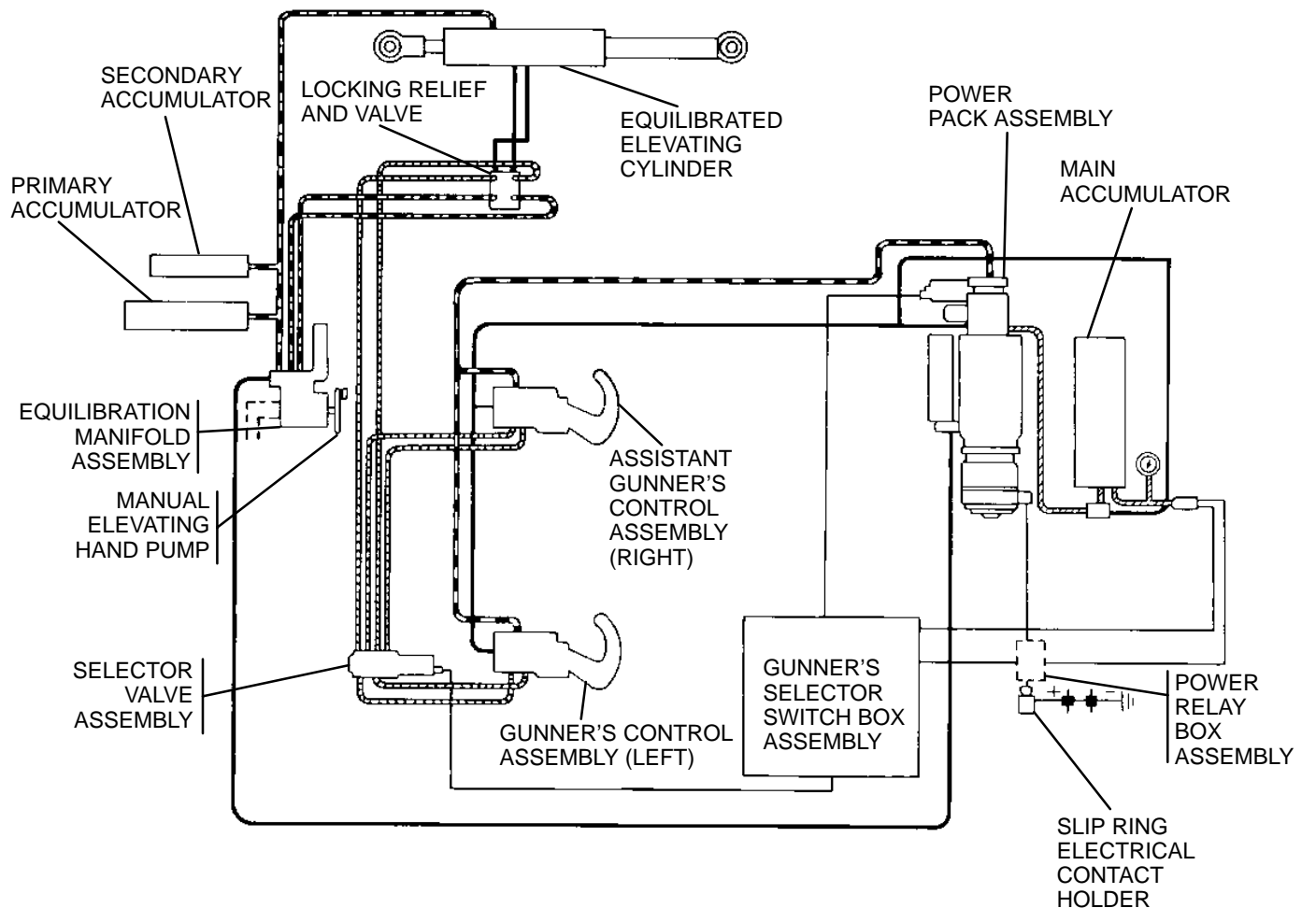
3-3 TROUBLESHOOTING CHART — CONTINUED

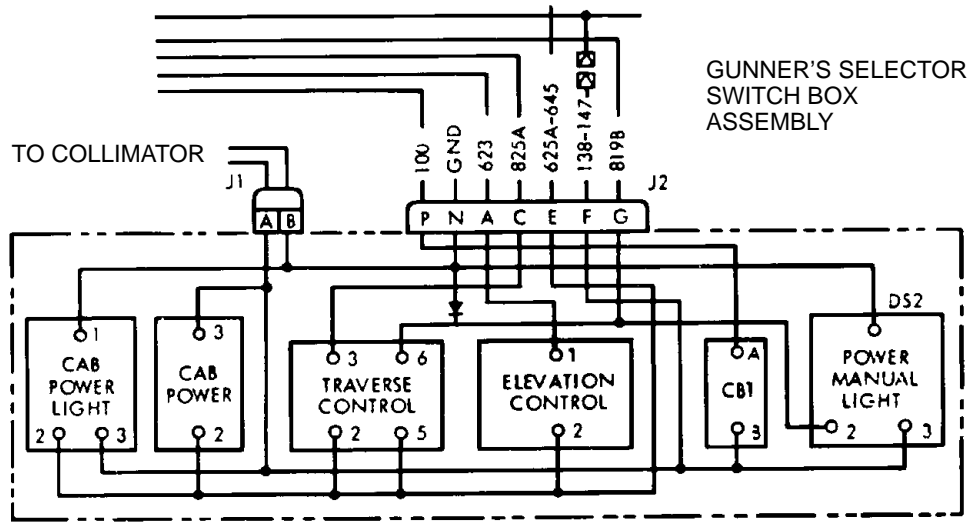
d. ELEVATING SYSTEM

The elevating system consists of a gunner's selector switch box assembly, assistant gunner's control assembly, gunner's control assembly, selector valve assembly, manual elevating hand pump, equilibration manifold assembly, primary accumulator, secondary accumulator, locking relief and valve, and the equilibrated elevating cylinder.

The gunner's selector switch box assembly is used to electrically switch between power and manual elevation through the selector valve assembly. The selector valve assembly allows for the powered elevation control from either of gunner's control assemblies. The gunner's control assembly, hydraulically operates the equilibrated elevating cylinder through the locking relief and valve.

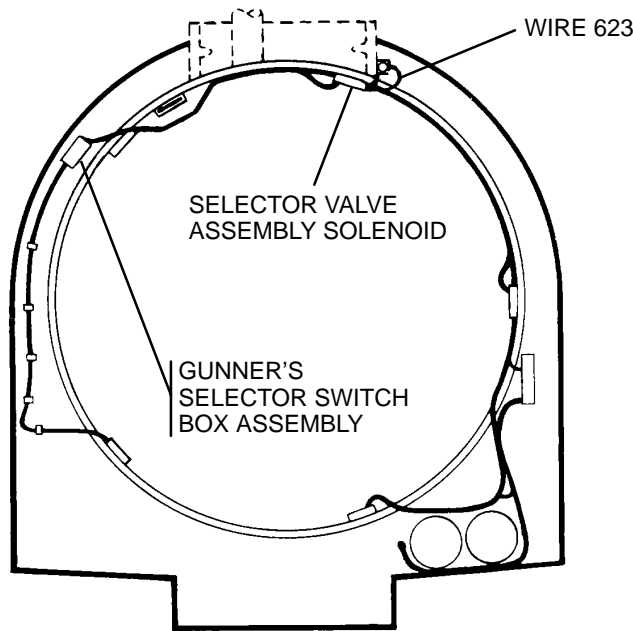
The equilibrated elevating cylinder can also be operated manually using the manual elevating hand pump at the equilibration manifold assembly. Hydraulic pressure is supplied by the primary and secondary accumulators and through the equilibration lines.



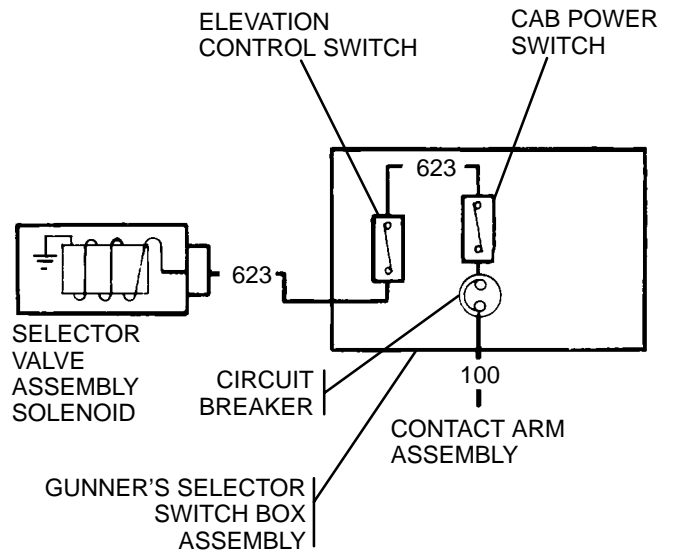


BLOCK DIAGRAM

ELEVATING CIRCUIT



PICTORIAL VIEW



ELECTRICAL DIAGRAM

**3-3 TROUBLESHOOTING CHART — CONTINUED**

d. ELEVATING SYSTEM — CONTINUED

(1) CANNON DOES NOT ELEVATE OR DEPRESS UNDER POWER OR MANUALLY, BUT HYDRAULIC PRESSURE IS NORMAL.

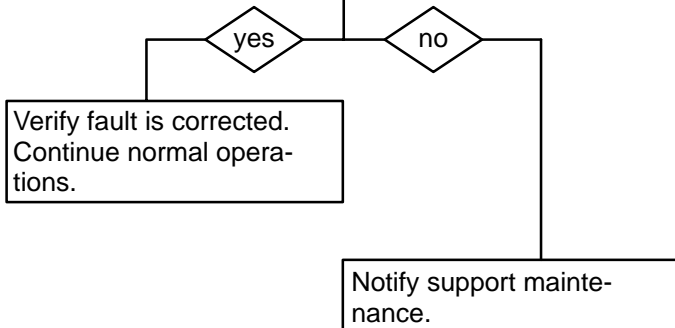
**INITIAL SETUP**

Tools

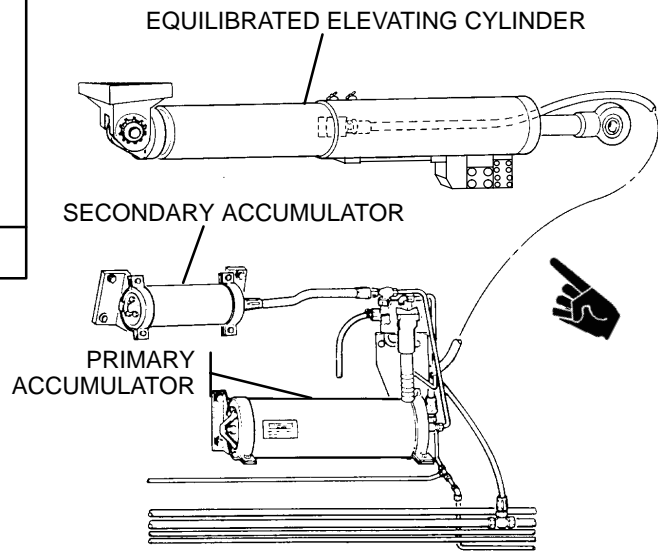
Artillery and turret mechanic's tool kit  
(SC 5180-95-CL-A12)

- A**
1. Check pressure of nitrogen charge in primary accumulator assembly (para 19-5), secondary accumulator (para 19-6), and manual pump accumulator assembly (para 19-3).
  2. Charge as necessary (para 19-5, 19-6, and 19-3).
  3. Adjust equilibrated elevating system after charging accumulators (para 6-3.1).

Does cannon elevate or depress?



**END OF TASK**



d. ELEVATING SYSTEM — CONTINUED

(2) CANNON MOVES BY ONLY ONE CONTROL HANDLE, BUT MANUAL OPERATION IS NORMAL.

**INITIAL SETUP**

Test Equipment

Multimeter (item 6, Appx H)

Tools

Artillery and turret mechanic's tool kit  
(SC 5180-95-CL-A12)

Personnel Required

2

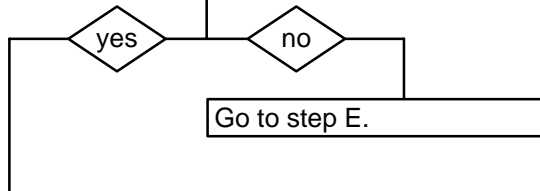
Equipment Condition

Vehicle MASTER switch to OFF (TM 9-2350-311-10)  
CAB POWER switch to OFF (TM 9-2350-311-10)

**A**

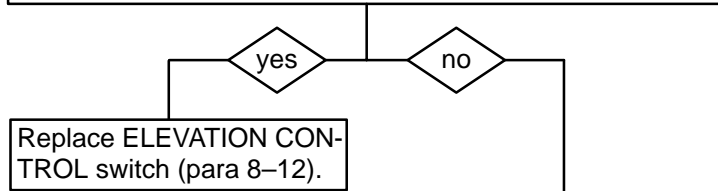
1. Disconnect wire 623 from selector valve assembly solenoid.
2. Turn MASTER and CAB POWER switches to ON.
3. Place ELEVATION CONTROL switch in GUNNER position.
4. Place red multimeter lead in wire 623 and black lead to ground.
5. Check for voltage.

Is battery voltage present?

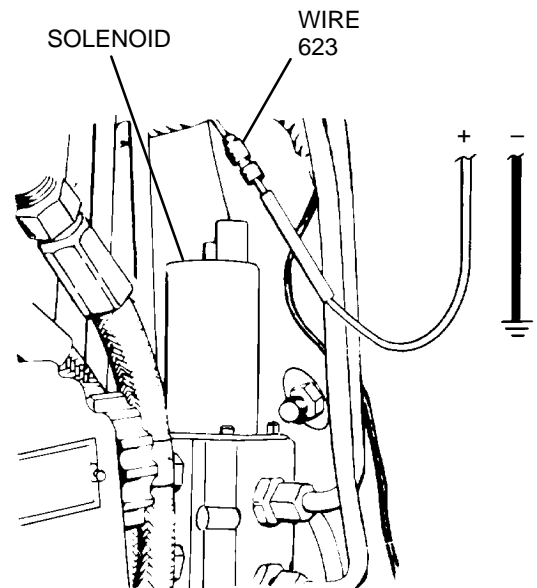


**B** Place ELEVATION CONTROL switch in NO. 1 MAN position.

Is battery voltage present?



CONTINUED ON NEXT PAGE





3-3 TROUBLESHOOTING CHART — CONTINUED

d. ELEVATING SYSTEM — CONTINUED

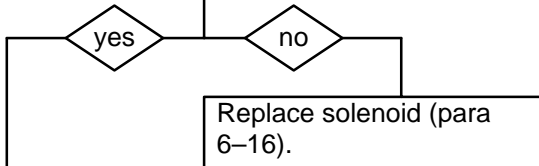
(2) CANNON MOVES BY ONLY ONE CONTROL HANDLE, BUT MANUAL OPERATION IS NORMAL. — CONTINUED

CONTINUED FROM STEP B

**C**

1. Turn MASTER and CAB POWER switches to OFF.
2. Discharge hydraulic pressure (para 6-3.1). Do not reconnect wire 645 at pressure switch.
3. Remove solenoid from selector valve assembly body (para 6-16).
4. Reconnect wire 623 to solenoid.
5. Depress plunger.
6. Ground edge of solenoid to valve body.
7. Turn MASTER and CAB POWER switches to ON.
8. Place ELEVATION CONTROL switch in GUNNER position.

Does plunger protrude from bottom of solenoid?

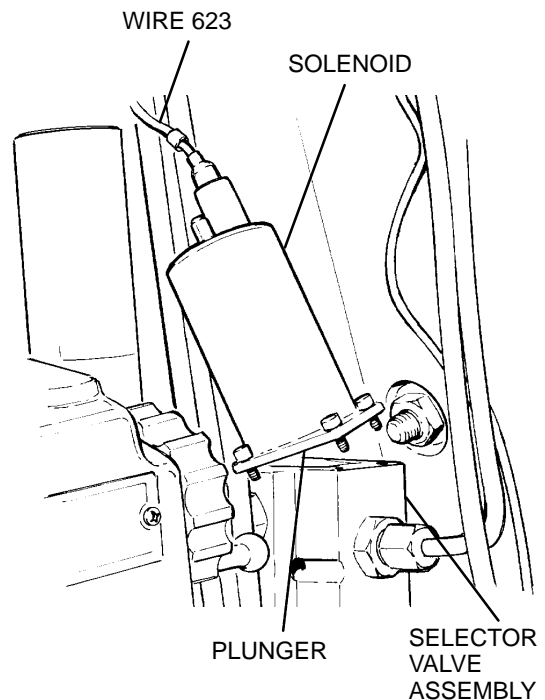


**D**

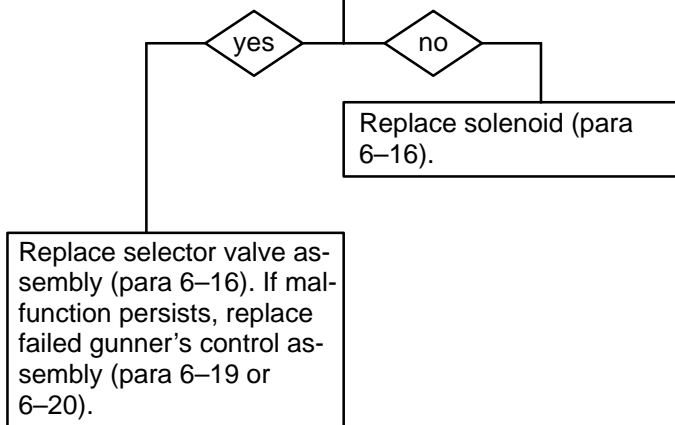
1. Place ELEVATION CONTROL switch in NO. 1 MAN position.
2. Apply small amount of pressure to plunger.

Does plunger retract?

CONTINUED ON NEXT PAGE

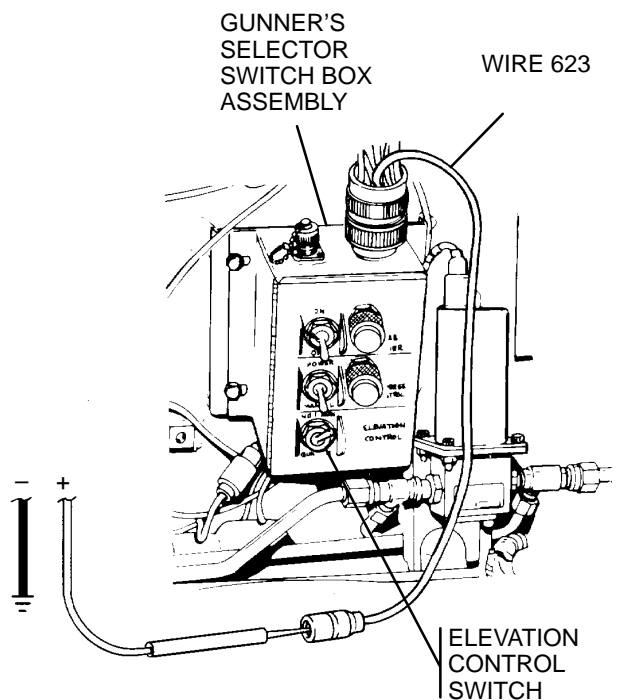
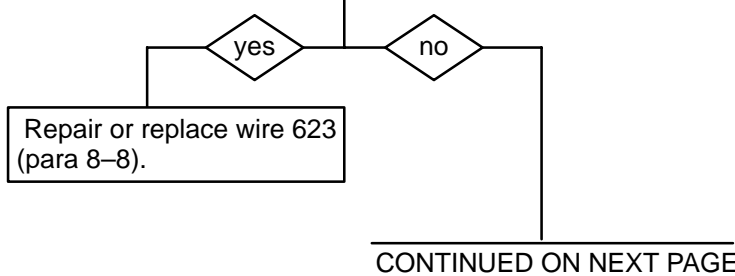


CONTINUED FROM STEP D



CONTINUED FROM STEP A

- E**
1. Turn MASTER and CAB POWER switches to OFF.
  2. Reconnect wire 623 to selector valve assembly solenoid.
  3. Place ELEVATION CONTROL switch in NO. 1 MAN position.
  4. Disconnect wire 623 from quick disconnect at gunner's selector switch box assembly.
  5. Place ELEVATION CONTROL switch in GUNNER position.
  6. Turn MASTER and CAB POWER switches to ON.
  7. Place red multimeter lead in wire 623 leading to gunner's selector switch box assembly and black lead to ground.
  8. Check for voltage.
- Is battery voltage present?



3-3 TROUBLESHOOTING CHART — CONTINUED

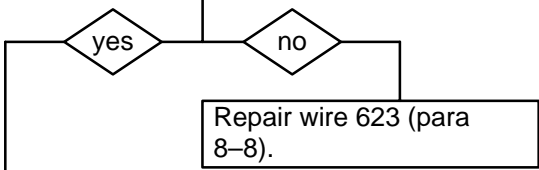
d. ELEVATING SYSTEM — CONTINUED

(2) CANNON MOVES BY ONLY ONE CONTROL HANDLE, BUT MANUAL OPERATION IS NORMAL. — CONTINUED

CONTINUED FROM STEP E

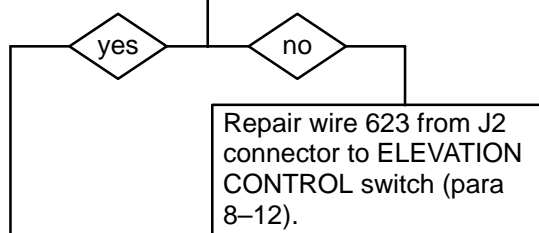
**F** 1. Turn MASTER and CAB POWER switches to OFF.  
 2. Disconnect harness at J2 connector of gunner's selector switch box assembly.  
 3. Place one multimeter lead at socket A of J2 connector harness and other lead to wire 623.  
 4. Check for continuity.

Is continuity present?

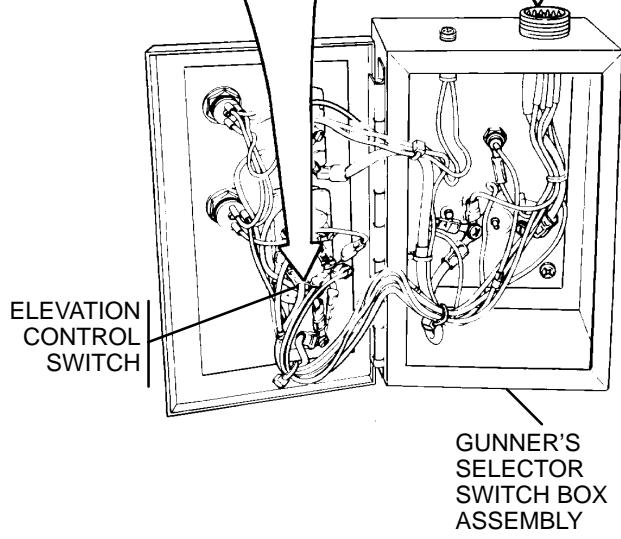
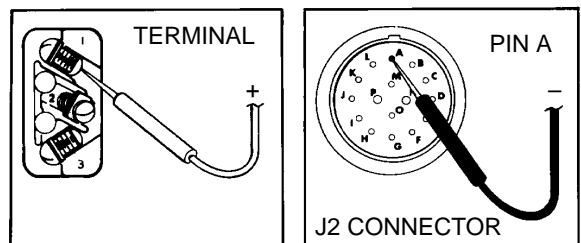
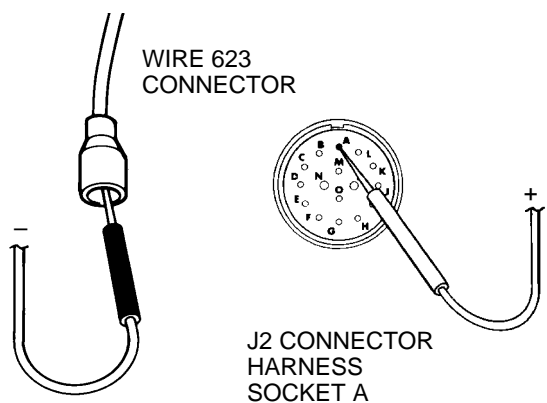


**G** 1. Reconnect wire 623 to quick-disconnect at gunner's selector switch box assembly.  
 2. Open gunner's selector switch box assembly.  
 3. Place one multimeter lead on terminal 1 of ELEVATION CONTROL switch and other lead to pin A of J2 connector.  
 4. Check for continuity.

Is continuity present?



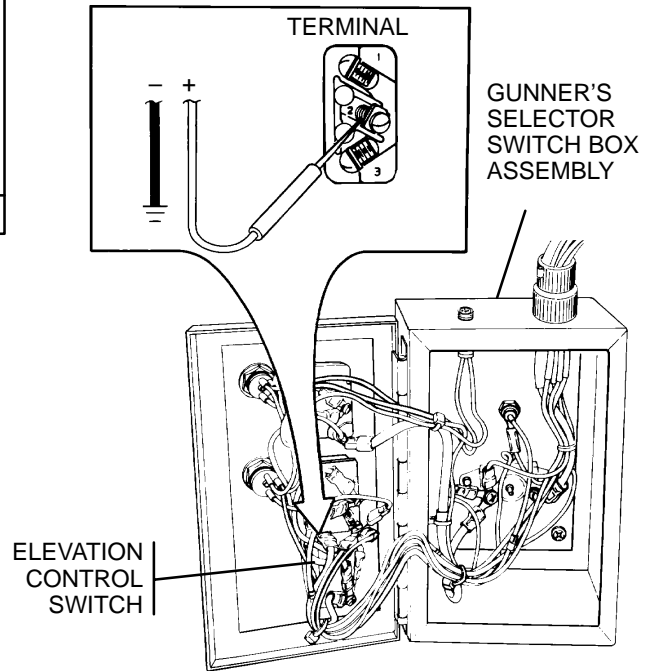
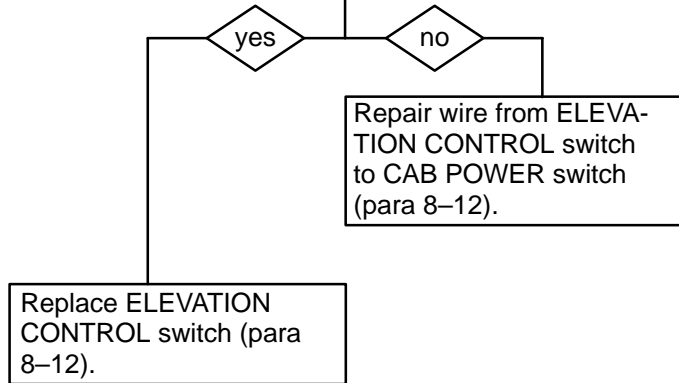
CONTINUED ON NEXT PAGE



CONTINUED FROM STEP G

- H**
1. Reconnect harness at J2 connector of gunner's selector switch box assembly.
  2. Turn MASTER and CAB POWER switches to ON.
  3. Place red multimeter lead on terminal 2 of ELEVATION CONTROL switch and black lead to ground.
  4. Check for voltage.

Is battery voltage present?



END OF TASK

**3-3 TROUBLESHOOTING CHART — CONTINUED**

d. ELEVATING SYSTEM — CONTINUED

(3) CANNON DOES NOT ELEVATE OR DEPRESS SMOOTHLY.

**INITIAL SETUP**

Tools

Artillery and turret mechanic's tool kit  
(SC 5180-95-CL-A12)

References

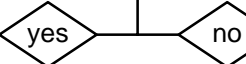
TM 9-214

**A** Inspect bearings in elevating cylinder eyes (TM 9-214) and elevation pivot pins.  
Do bearings or pins need replacement?



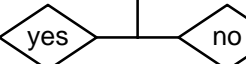
Notify support maintenance.

**B** Bleed air from equilibrated elevation hydraulic system (para 6-3.1).  
Will cannon elevate and depress smoothly?

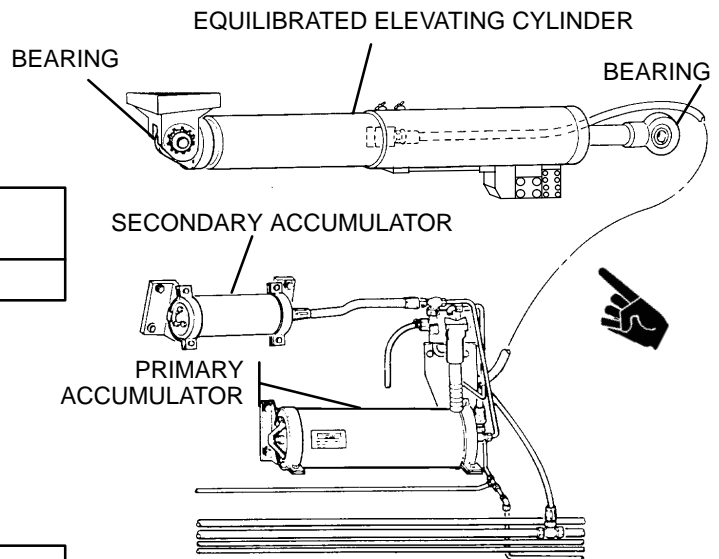


Verify fault is corrected. Continue normal operations.

**C** Check nitrogen precharge in primary accumulator (para 19-5).  
Is pressure abnormal?



Charge primary accumulator (para 19-5). Perform leak test (para 6-11).



CONTINUED ON NEXT PAGE

CONTINUED FROM STEP C

**D** Check nitrogen precharge in secondary accumulator (para 19-6).  
Is pressure below normal?

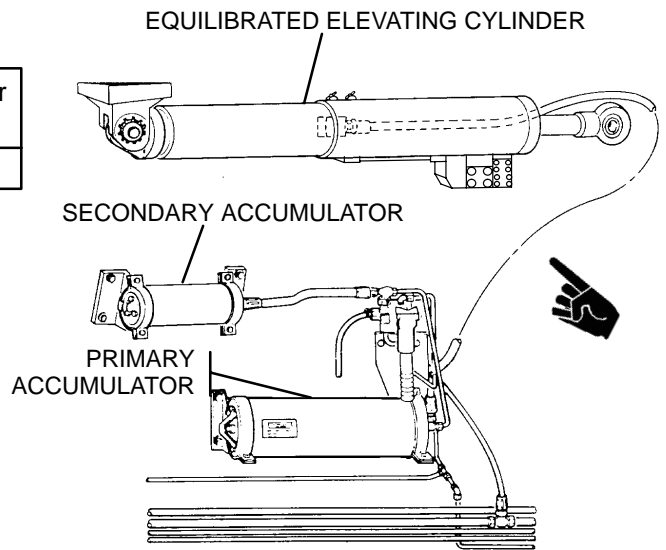
yes

no

Charge secondary accumulator (para 19-6). Perform leak test (para 6-12).

Notify support maintenance.

END OF TASK



3-3 TROUBLESHOOTING CHART — CONTINUED

d. ELEVATING SYSTEM — CONTINUED

(4) CANNON DOES NOT ELEVATE OR DEPRESS USING MANUAL ELEVATION SYSTEM OR SYSTEM IS INEFFICIENT, BUT CANNON WILL OPERATE UNDER POWER.

**INITIAL SETUP**

Tools

Artillery and turret mechanic's tool kit (SC 5180-95-CL-A12)

Materials/Parts

Hydraulic fluid OHT (item 21, Appx D)

References

TM 9-2350-311-10

**A** Equilibrate elevating cylinder if necessary (TM 9-2350-311-10).  
Does system operate properly?

yes

no

Verify fault is corrected. Continue normal operations.

**B**

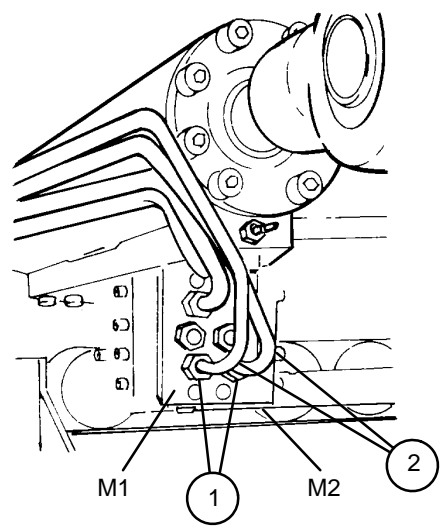
1. Loosen two hex nuts (1) at ports M1 and M2.
2. Drain off pressurized fluids through manual elevation tubes (2) until bubble free fluid flows.
3. Tighten two hex nuts (1) to secure manual elevation tubes (2).
4. Rotate manual elevating hand pump counterclockwise until movement is detected in equilibrated elevating cylinder.
5. Bleed elevating cylinders (para 6-3.1).

Does cannon move manually?

yes

no

Verify fault is corrected. Continue normal operations.

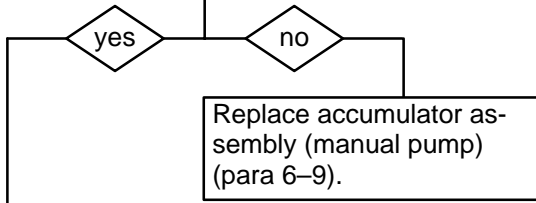


CONTINUED ON NEXT PAGE

CONTINUED FROM STEP B

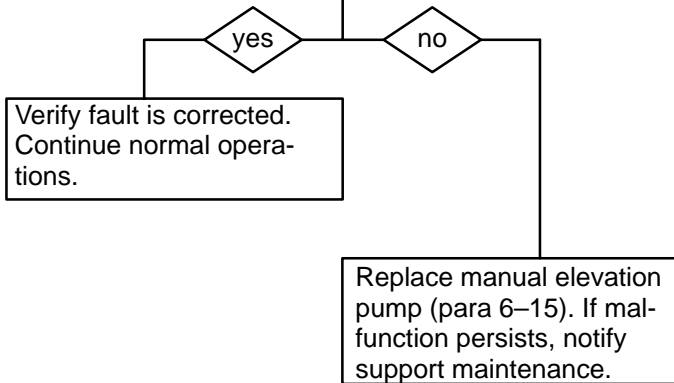
**C** 1. Check pressure of nitrogen charge in manual pump accumulator assembly (para 6-9).  
 2. Charge if pressure is not 75-90 psi (517-620 kPa) (para 19-3).  
 3. Check to see that charge holds.

Does accumulator hold charge?

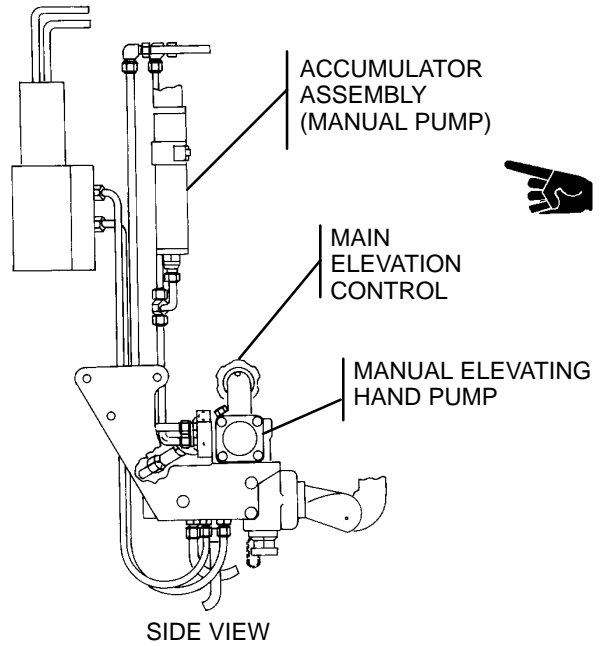


**D** Attempt to elevate and depress the system using manual elevating hand pump.

Does cannon elevate or depress manually?



END OF TASK





### 3-3 TROUBLESHOOTING — CONTINUED

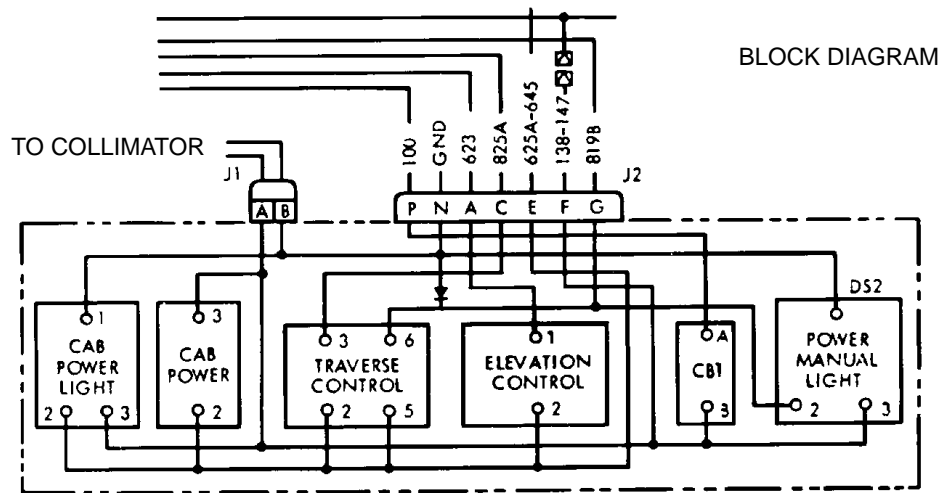
#### e. CAB HYDRAULIC SYSTEM

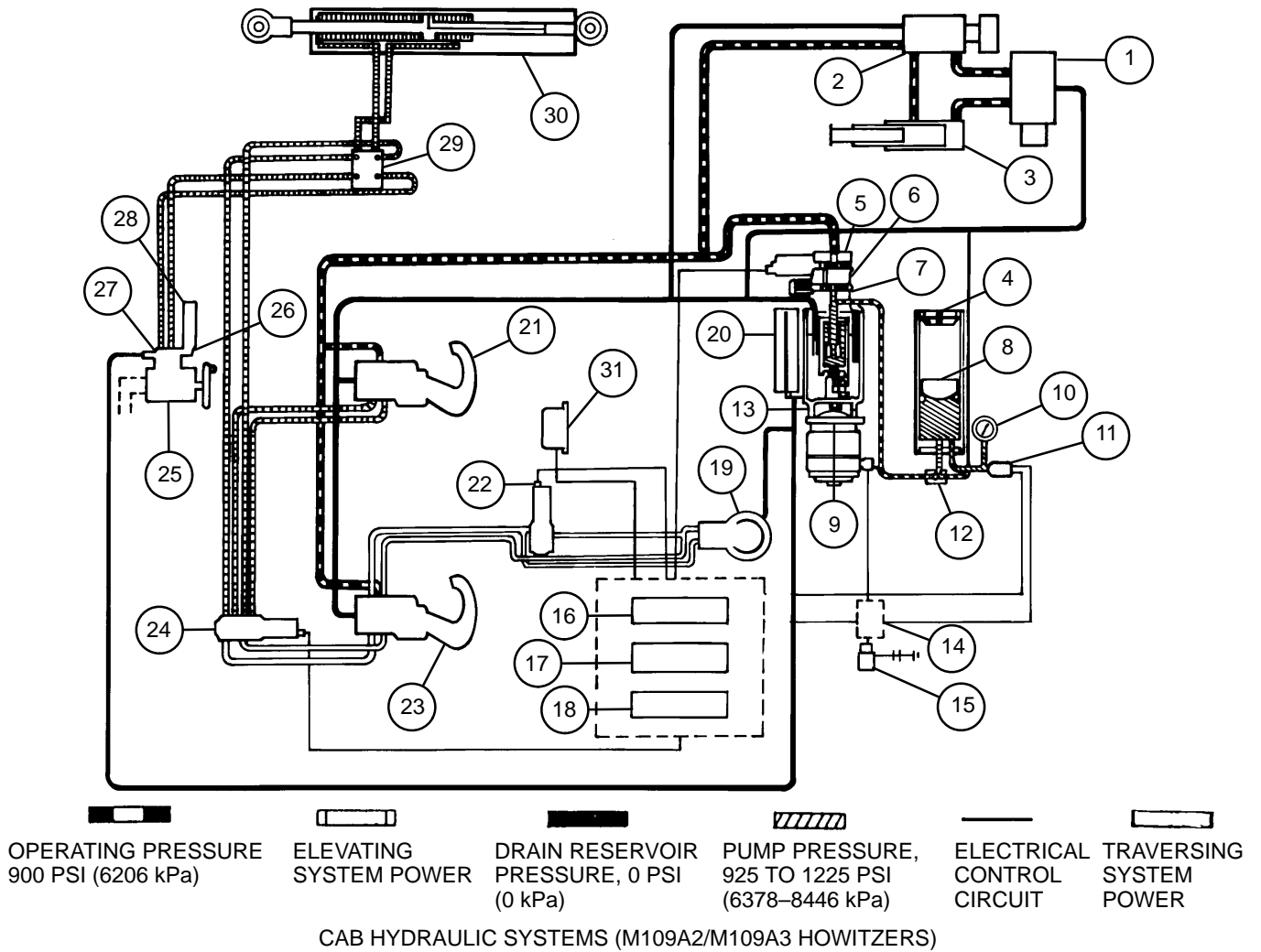
The cab hydraulic system consists of the hydraulic components of the cab elevating system, the cab traversing system, the hydraulic pump, the main accumulator, and the electrical contacts to the hull.

The hydraulic system receives electrical power through the slip ring brush holder and power relay box assembly. Electricity is provided to the gunner's selector switch box assembly, the hydraulic pump, and the main accumulator pressure switch.

Hydraulic power is provided to the system by way of the pressure regulator, power valve, and power pack assembly.

Other components include sight gage assembly, pump reservoir, and system pressure gage.





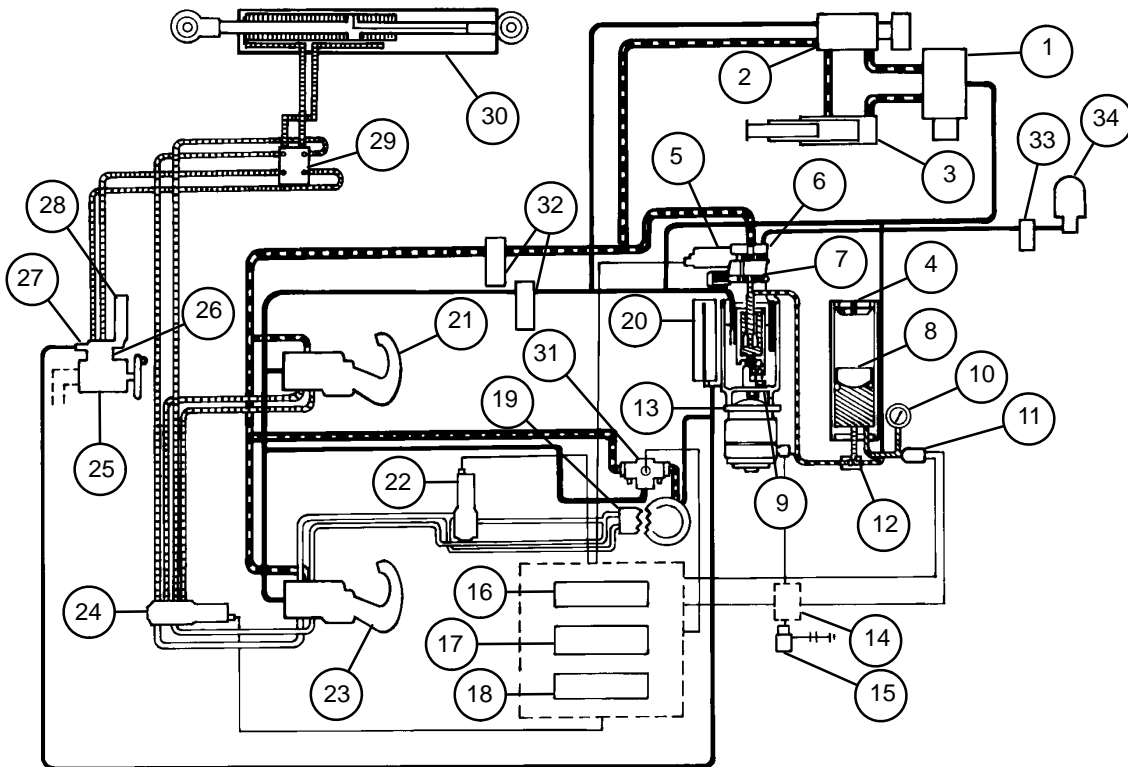
**LEGEND:**

- |  |   |
|--|---|
| <ul style="list-style-type: none"> <li>1. Rammer blocking valve</li> <li>2. Rammer actuating valve</li> <li>3. Rammer assembly</li> <li>4. Main accumulator</li> <li>5. Power pack assembly</li> <li>6. Power valve</li> <li>7. Pressure regulator</li> <li>8. Cylinder</li> <li>9. Pump</li> <li>10. Pressure gage (2000 psi (13790 kPa))</li> <li>11. Pressure switch (925 to 1225 psi (6378 to 8446 kPa))</li> <li>12. Safety relief valve</li> <li>13. Reservoir</li> <li>14. Power relay box assembly</li> <li>15. Slip ring electrical contact holder</li> <li>16. ELEVATION CONTROL switch</li> </ul> | <ul style="list-style-type: none"> <li>17. TRAVERSE CONTROL switch</li> <li>18. CAB POWER switch</li> <li>19. Traversing mechanism hydraulic motor</li> <li>20. Sight gage assembly</li> <li>21. Right gunner's control assembly</li> <li>22. Hydraulic bypass valve assembly motor</li> <li>23. Left gunner's control assembly</li> <li>24. Elevation selector valve assembly</li> <li>25. Manual elevating hand pump</li> <li>26. Shuttle valve and equilibration manifold assembly</li> <li>27. Check valve</li> <li>28. Manual elevation accumulator</li> <li>29. Elevating cylinder locking and relief valve</li> <li>30. Equilibrated elevating cylinder</li> <li>31. Clutch</li> </ul> |
|--|---|

3-3 TROUBLESHOOTING — CONTINUED

e. CAB HYDRAULIC SYSTEM — CONTINUED

CAB HYDRAULIC SYSTEMS (M109A4/M109A5 HOWITZERS)

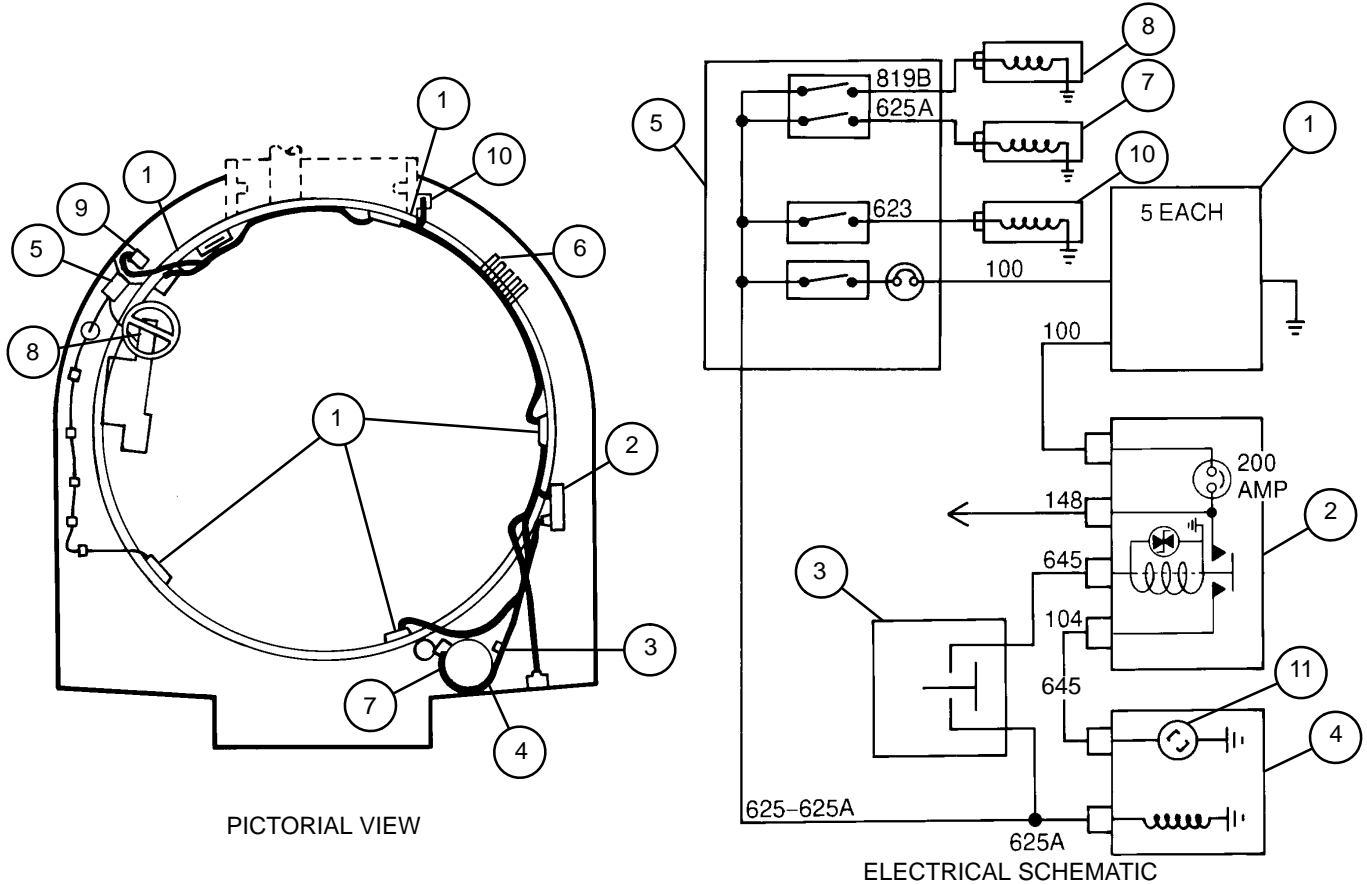


OPERATING PRESSURE 900 PSI (6206 kPa)	ELEVATING SYSTEM POWER	DRAIN RESERVOIR PRESSURE, 0 PSI (0 kPa)	PUMP PRESSURE, 925 TO 1225 PSI (6378-8446 kPa)	ELECTRICAL CONTROL CIRCUIT	TRAVERSING SYSTEM POWER

LEGEND:

- |  |   |   |
|--|---|---|
| 1. Rammer blocking valve                                 | 13. Reservoir                                   | 24. Elevation selector valve assembly                 |
| 2. Rammer actuating valve                                | 14. Power relay box assembly                    | 25. Manual elevating hand pump                        |
| 3. Rammer assembly                                       | 15. Slip ring electrical contact holder         | 26. Shuttle valve and equilibration manifold assembly |
| 4. Main accumulator                                      | 16. ELEVATION CONTROL switch                    | 27. Check valve                                       |
| 5. Power pack assembly                                   | 17. TRAVERSE CONTROL switch                     | 28. Manual elevation accumulator                      |
| 6. Power valve   | 18. CAB POWER switch                            | 29. Elevating cylinder locking and relief valve       |
| 7. Pressure regulator                                    | 19. Traversing mechanism hydraulic motor        | 30. Equilibrated elevating cylinder                   |
| 8. Cylinder  | 20. Sight gage assembly                         | 31. Clutch valve                                      |
| 9. Pump  | 21. Right gunner's control assembly             | 32. Hydraulic filters                                 |
| 10. Pressure gage (2000 psi (13790 kPa))                 | 22. Hydraulic motor bypass valve assembly motor | 33. Air line filter                                   |
| 11. Pressure switch (925 to 1225 psi (6378 to 8446 kPa)) | 23. Left gunner's control assembly              | 34. Hygroscopic breather                              |
| 12. Safety relief valve                                  |   |   |

CAB POWER PACK HYDRAULIC PUMP DRIVE MOTOR CIRCUIT (M109A2/M109A3 HOWITZERS)



PICTORIAL VIEW

ELECTRICAL SCHEMATIC

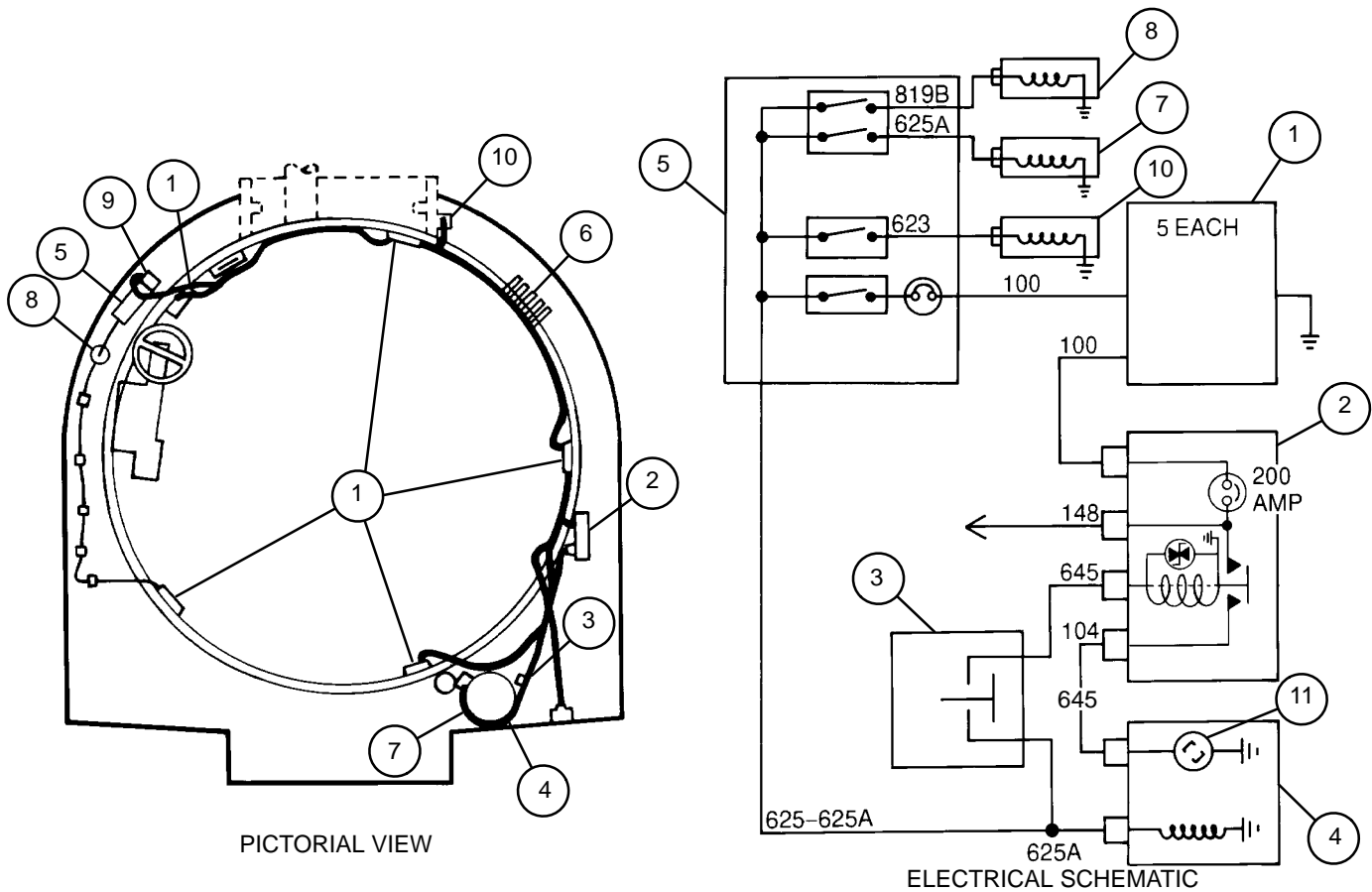
LEGEND:

- |  |   |
|--|---|
| <ul style="list-style-type: none"> <li>1. Contact arm assembly</li> <li>2. Power relay box assembly</li> <li>3. Pressure switch</li> <li>4. Power pack assembly</li> <li>5. Gunner's selector switch box assembly</li> <li>6. Segment board</li> </ul> | <ul style="list-style-type: none"> <li>7. Power valve solenoid</li> <li>8. Traverse clutch</li> <li>9. Traverse bypass valve assembly</li> <li>10. Elevation selector valve assembly</li> <li>11. Hydraulic pump motor</li> </ul> |
|--|---|

3-3 TROUBLESHOOTING — CONTINUED

e. CAB HYDRAULIC SYSTEM — CONTINUED

CAB POWER PACK HYDRAULIC PUMP DRIVE MOTOR CIRCUIT (M109A4/M109A5 HOWITZERS)



LEGEND:

- |  |                                       |
|--|---------------------------------------|
| 1. Contact arm assembly                  | 7. Power valve solenoid               |
| 2. Power relay box assembly              | 8. Clutch valve solenoid              |
| 3. Pressure switch                       | 9. Traverse bypass valve assembly     |
| 4. Power pack assembly                   | 10. Elevation selector valve assembly |
| 5. Gunner's selector switch box assembly | 11. Hydraulic pump motor              |
| 6. Segment board                         |                                       |

e. CAB HYDRAULIC SYSTEM — CONTINUED

(1) POWER PACK HYDRAULIC PUMP MOTOR DOES NOT OPERATE, BUT CAB LIGHTING SYSTEM OPERATES NORMALLY.

**INITIAL SETUP**

Test Equipment

Multimeter (item 6, Appx H)

Tools

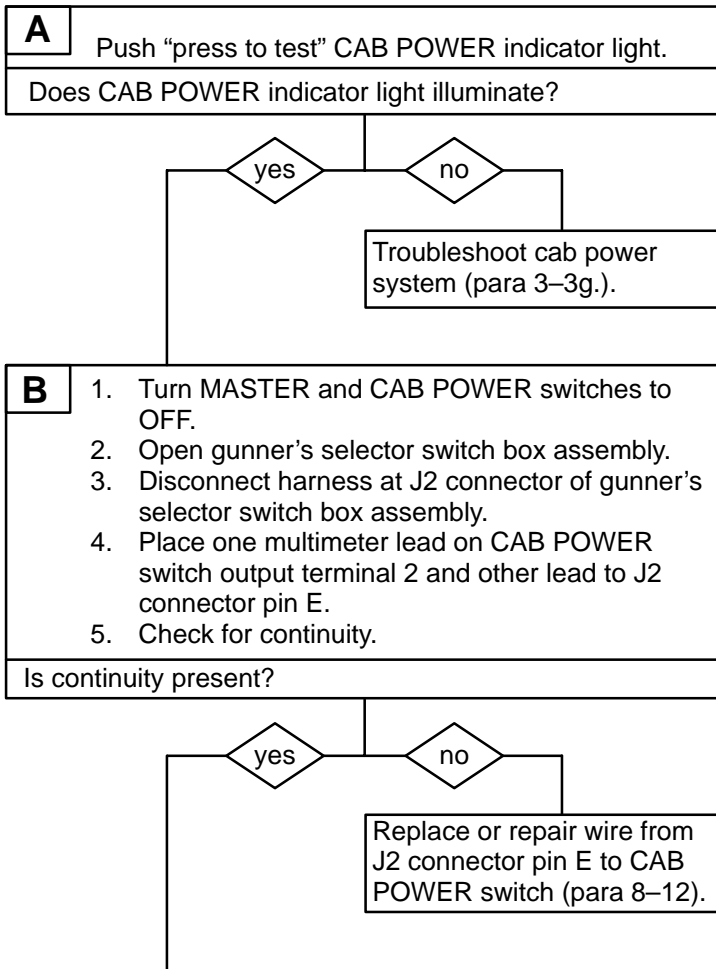
Artillery and turret mechanic's tool kit  
(SC 5180-95-CL-A12)

References

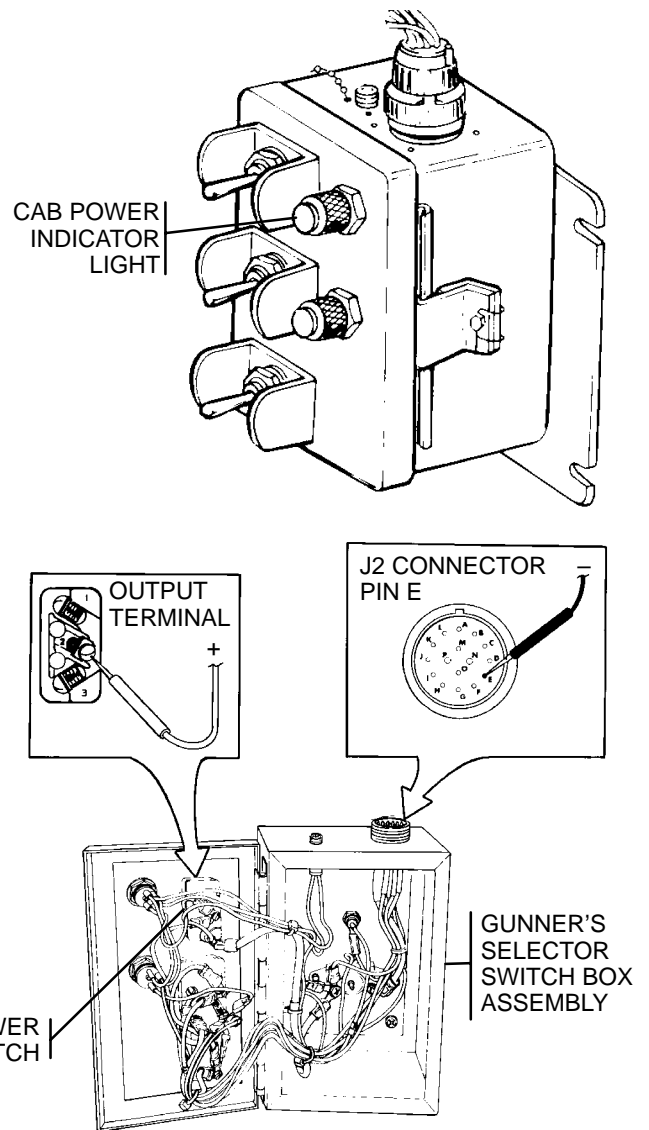
TM 9-2350-311-20-1

Equipment Condition

Vehicle MASTER switch to ON (TM 9-2350-311-10)  
CAB POWER switch to ON (TM 9-2350-311-10)



CONTINUED ON NEXT PAGE



3-3 TROUBLESHOOTING — CONTINUED

e. CAB HYDRAULIC SYSTEM — CONTINUED

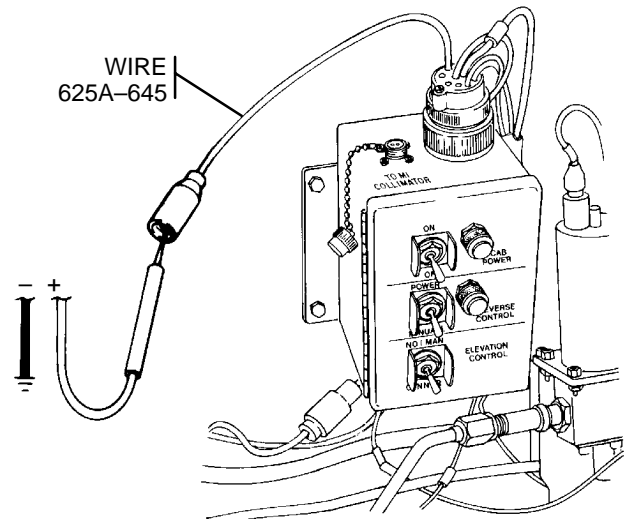
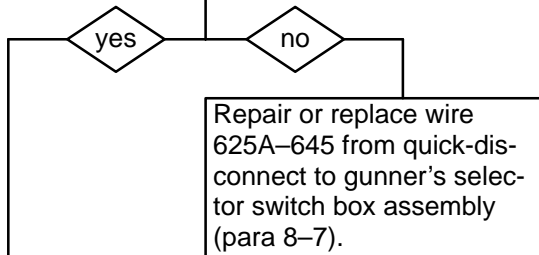
(1) POWER PACK HYDRAULIC PUMP MOTOR DOES NOT OPERATE, BUT CAB LIGHTING SYSTEM OPERATES NORMALLY. — CONTINUED

CONTINUED FROM STEP B

**C**

1. Close gunner's selector switch box assembly.
2. Reconnect harness at J2 connector of gunner's selector switch box assembly.
3. Disconnect wire 625A-645 from quick-disconnect at gunner's selector switch box assembly.
4. Place red multimeter lead in wire 625A-645 and black lead to ground.
5. Turn MASTER and CAB POWER switches to ON.
6. Check for voltage.

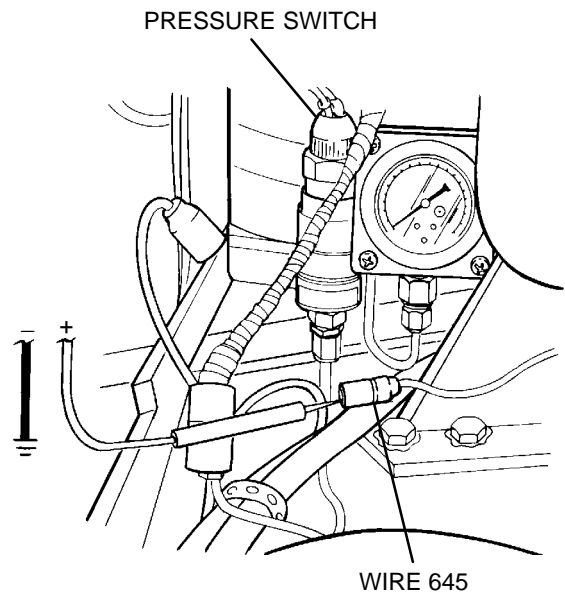
Is battery voltage present?



**D**

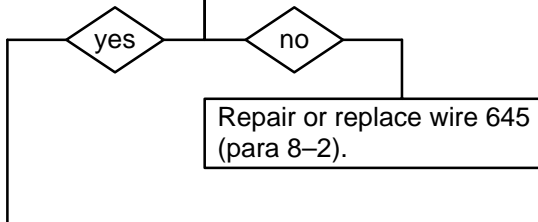
1. Turn MASTER and CAB POWER switches to OFF.
2. Reconnect wire 625A-645 to quick-disconnect at gunner's selector switch box assembly.
3. Disconnect wire 645 from quick-disconnect at pressure switch.
4. Turn MASTER and CAB POWER switches to ON.
5. Place red multimeter lead in wire 645 and black lead to ground.
6. Check for voltage.

Is battery voltage present?



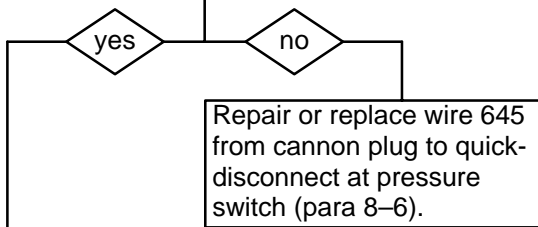
CONTINUED ON NEXT PAGE

CONTINUED FROM STEP D



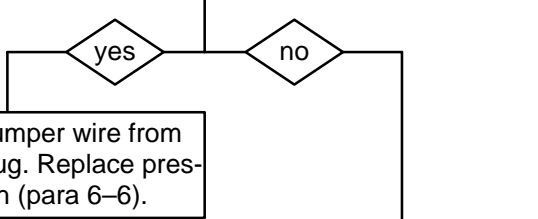
- E**
1. Turn MASTER and CAB POWER switches to OFF.
  2. Reconnect wire 645 to quick-disconnect at pressure switch.
  3. Disconnect cannon plug from top of pressure switch.
  4. Turn MASTER and CAB POWER switches to ON.
  5. Place red multimeter lead in cannon plug socket A and black lead to ground.
  6. Check for voltage.

Is battery voltage present?

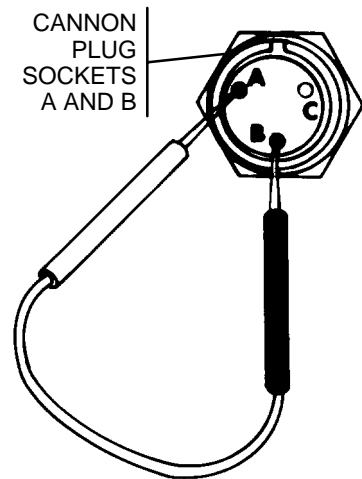
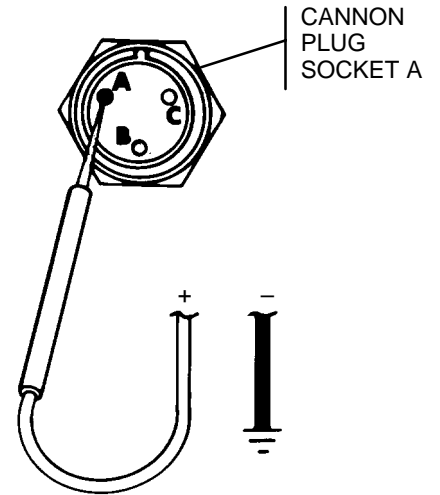


- F**
1. Turn MASTER and CAB POWER switches to OFF.
  2. Connect jumper wire to A and B socket holes in cannon plug.
  3. Turn MASTER and CAB POWER switches to ON.

Does hydraulic pump motor come on?



CONTINUED ON NEXT PAGE





3-3 TROUBLESHOOTING — CONTINUED

e. CAB HYDRAULIC SYSTEM — CONTINUED

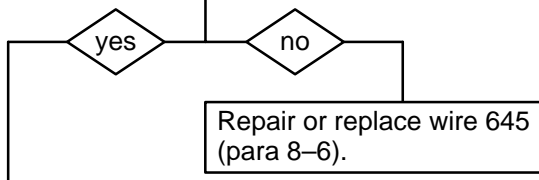
(1) POWER PACK HYDRAULIC PUMP MOTOR DOES NOT OPERATE, BUT CAB LIGHTING SYSTEM OPERATES NORMALLY. — CONTINUED

CONTINUED FROM STEP F

**G**

1. Turn MASTER and CAB POWER switches to OFF.
2. Leave jumper wire in place.
3. Disconnect wire 645 at power relay box assembly.
4. Turn MASTER and CAB POWER switches to ON.
5. Place red multimeter lead in wire 645 and black lead to ground.
6. Check for voltage.

Is battery voltage present?

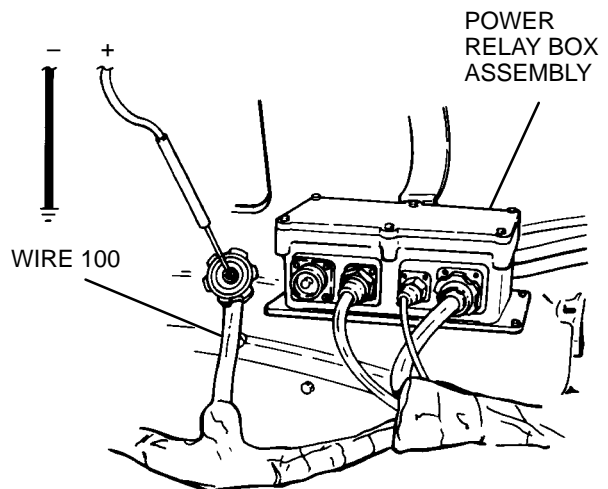
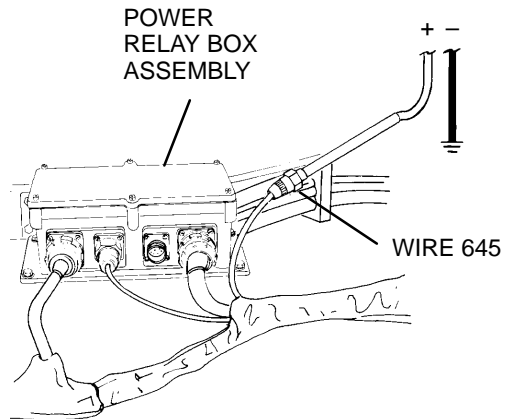


**H**

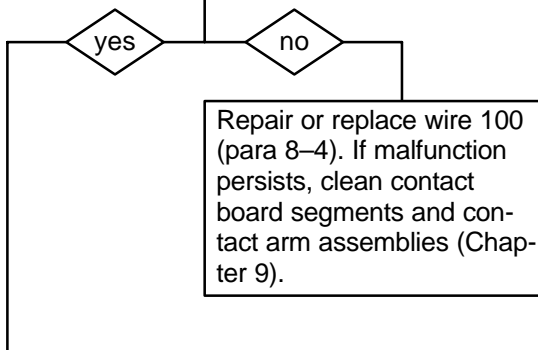
1. Turn MASTER and CAB POWER switches to OFF.
2. Ensure hydraulic pressure in power pack main accumulator is below 925 psi (6378 kPa).
3. Remove jumper wire from cannon plug and reconnect cannon plug to pressure switch.
4. Reconnect wire 645 to power relay box assembly.
5. Disconnect wire 100 at power relay box assembly.
6. Turn MASTER switch to ON.
7. Place red multimeter lead in wire 100 connector and black lead to ground.
8. Check for voltage.

Is battery voltage present?

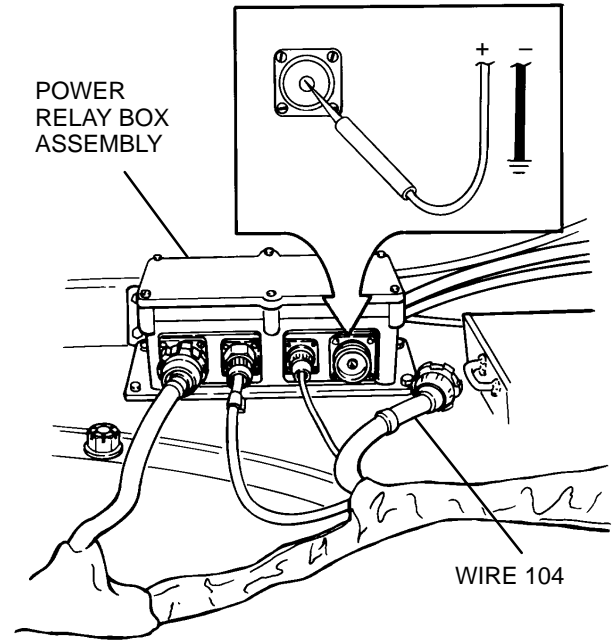
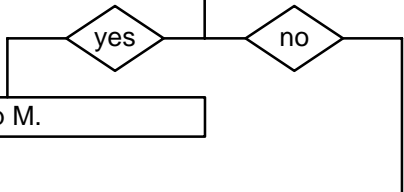
CONTINUED ON NEXT PAGE



CONTINUED FROM STEP H



- |                             |  |
|-----------------------------|--|
| <b>I</b>                    | <ol style="list-style-type: none"> <li>1. Turn MASTER switch to OFF.</li> <li>2. Reconnect wire 100 to power relay box assembly.</li> <li>3. Disconnect wire 104 at power relay box assembly.</li> <li>4. Turn MASTER and CAB POWER switches to ON.</li> <li>5. Ensure that hydraulic pressure in power pack main accumulator assembly is below 925 psi (6378 kPa).</li> <li>6. Place red multimeter lead in power relay box assembly connector for wire 104 and black lead to ground.</li> <li>7. Check for voltage.</li> </ol> |
| Is battery voltage present? |  |



CONTINUED ON NEXT PAGE

3-3 TROUBLESHOOTING — CONTINUED

e. CAB HYDRAULIC SYSTEM — CONTINUED

(1) POWER PACK HYDRAULIC PUMP MOTOR DOES NOT OPERATE, BUT CAB LIGHTING SYSTEM OPERATES NORMALLY. — CONTINUED

CONTINUED FROM STEP I

**CAUTION**

Low voltage in battery can cause points to stick on the power relay. Check battery voltage prior to doing step J (TM 9-2350-311-20-1).

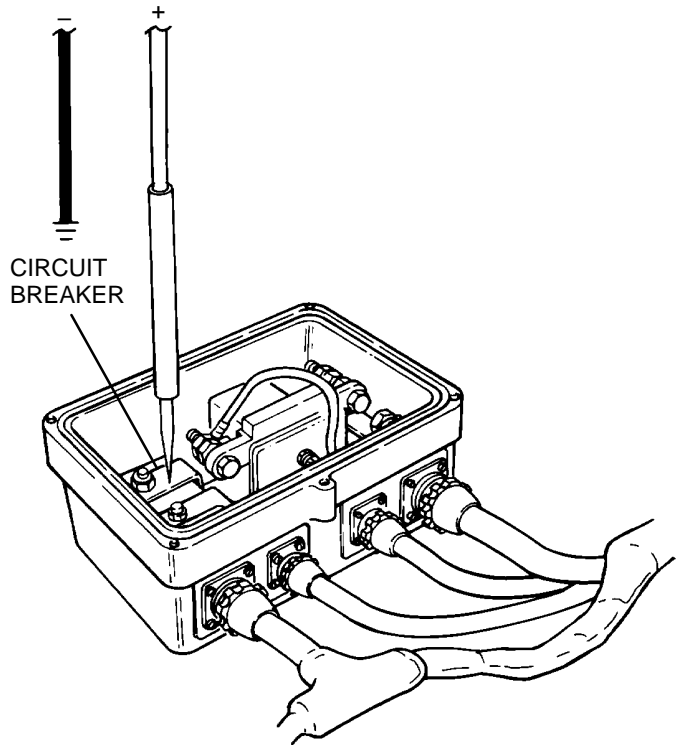
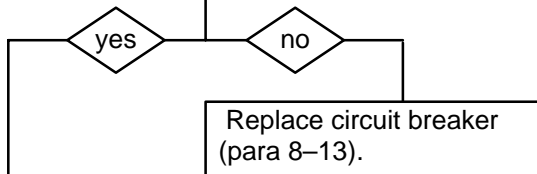
**NOTE**

NBC control box assembly must be removed to open cab power relay box assembly in M109A4/M109A5 howitzers (para 17-4).

**J**

1. Turn MASTER and CAB POWER switches to OFF.
2. Reconnect wire 104 to power relay box assembly.
3. Remove distribution cover from power relay box assembly (para 8-13).
4. Turn MASTER and CAB POWER switches to ON.
5. Place red multimeter lead on output bus bar of circuit breaker and black lead to ground.
6. Check for voltage.

Is battery voltage present?



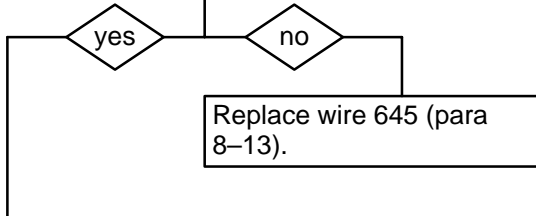
CONTINUED ON NEXT PAGE

CONTINUED FROM STEP J

**K**

1. Ensure that hydraulic pressure in power pack main accumulator assembly is below 925 psi (6378 kPa).
2. Place red multimeter lead on wire 645 post of electromagnetic relay and black lead to ground.
3. Check for voltage.

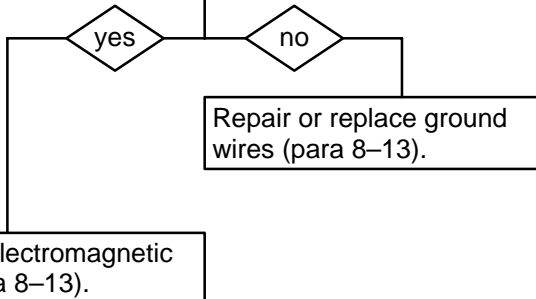
Is battery voltage present?



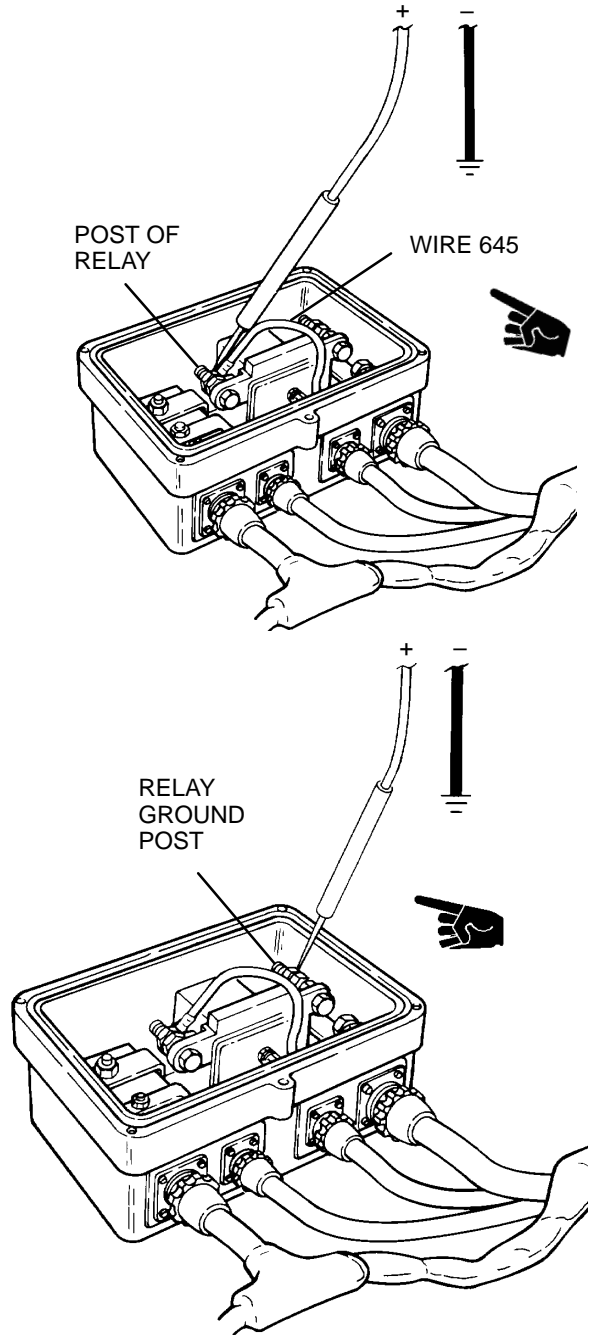
**L**

1. Turn MASTER and CAB POWER switches to OFF.
2. Place one multimeter lead on electromagnetic relay ground post and other lead to ground.
3. Check for continuity.

Is continuity present?



CONTINUED ON NEXT PAGE



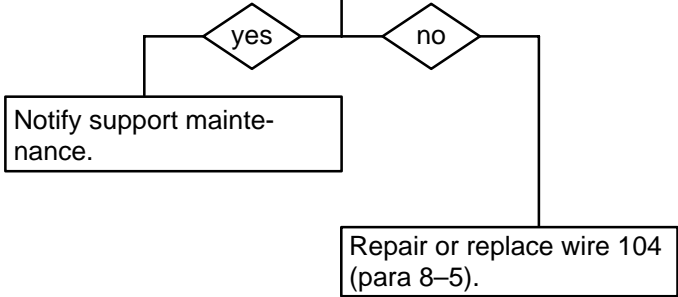
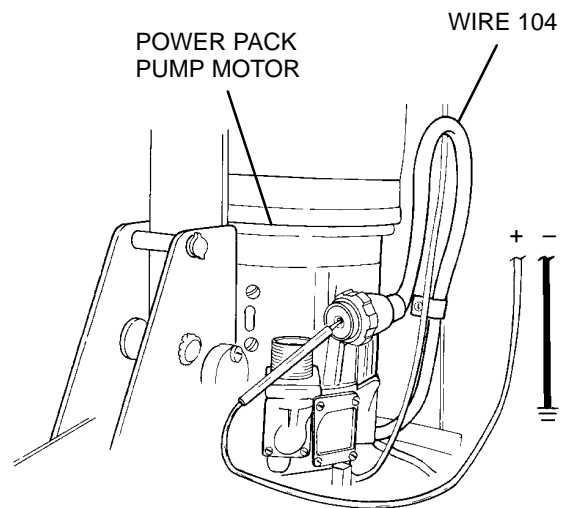
3-3 TROUBLESHOOTING — CONTINUED

e. CAB HYDRAULIC SYSTEM — CONTINUED

(1) POWER PACK HYDRAULIC PUMP MOTOR DOES NOT OPERATE, BUT CAB LIGHTING SYSTEM OPERATES NORMALLY. — CONTINUED

CONTINUED FROM STEP I

- |                             |  |
|-----------------------------|--|
| <b>M</b>                    | <ol style="list-style-type: none"> <li>1. Turn MASTER and CAB POWER switches to OFF.</li> <li>2. Reconnect wire 104 to power relay box assembly.</li> <li>3. Disconnect wire 104 at power pack pump motor.</li> <li>4. Turn MASTER and CAB POWER switches to ON.</li> <li>5. Ensure power pack main accumulator assembly pressure is below 925 psi (6378 kPa).</li> <li>6. Place red multimeter lead in wire 104 connector and black lead to ground.</li> <li>7. Check for voltage.</li> </ol> |
| Is battery voltage present? |  |



END OF TASK

e. CAB HYDRAULIC SYSTEM — CONTINUED

(2) HYDRAULIC PRESSURE IS NORMAL, BUT HYDRAULIC POWER IS NOT BEING SUPPLIED.

**INITIAL SETUP**

Test Equipment

Multimeter (item 6, Appx H)

Personnel Required

2

Tools

Artillery and turret mechanic's tool kit  
 (SC 4933-95-A12)

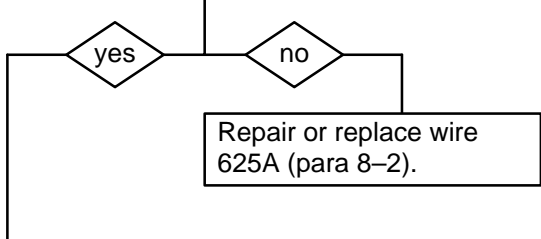
Equipment Condition

Vehicle MASTER switch to OFF (TM 9-2350-311-10)  
 CAB POWER switch to OFF (TM 9-2350-311-10)  
 Cab access cover removed (para 14-11)

**A**

1. Disconnect wire 625A at power pack solenoid.
2. Turn MASTER and CAB POWER switches to ON.
3. Place red multimeter lead in wire 625A and black lead to ground.
4. Check for voltage.

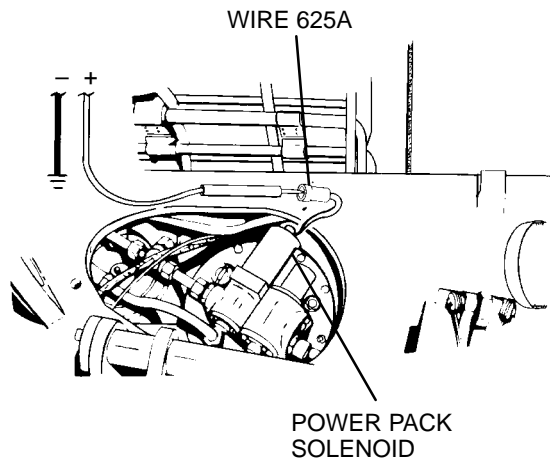
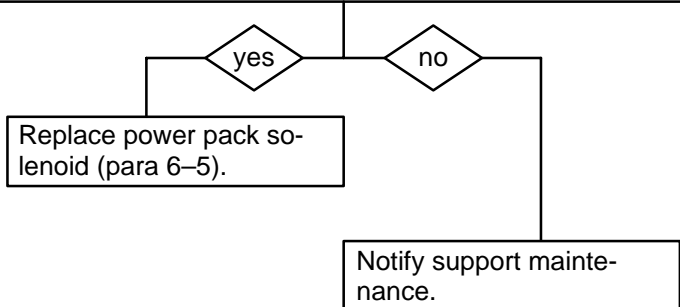
Is battery voltage present?



**B**

1. Turn MASTER and CAB POWER switches to OFF.
2. Have one man depress plunger on power pack solenoid at top of power pack with screwdriver.
3. Have second man traverse (left or right) and hold left gunner's control handle until accumulator pressure gage reads zero.

Can hydraulic system be discharged?



**END OF TASK**

3-3 TROUBLESHOOTING — CONTINUED

e. CAB HYDRAULIC SYSTEM — CONTINUED

(3) HYDRAULIC FLUID OVERFLOWS FROM TOP OF SIGHT GAGE OR CONTAMINATED CRYSTALS IN HYDROSCOPIC BREATHER.

**INITIAL SETUP**

Tools

Artillery and turret mechanic's tool kit  
(SC 5180-95-CL-A12)  
Utility pail (item 7, Appx H)

Materials/Parts

Hydraulic fluid OHT (item 21, Appx D)

Equipment Condition

Cab access cover removed (para 14-11)

**NOTE**

A loss of nitrogen pressure in the main accumulator assembly will affect hydraulic fluid level reading on sight gage. Sight gage will show hydraulic fluid level to be low. Adding hydraulic fluid to compensate for this loss of nitrogen will result in an overflow of hydraulic fluid from top of sight gage when system is discharged.

- A**
1. Discharge pressure in hydraulic system (para 6-3).
  2. Check power pack gage for hydraulic fluid level.

Is fluid level over FULL AT 0 PRESSURE mark?

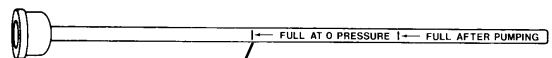
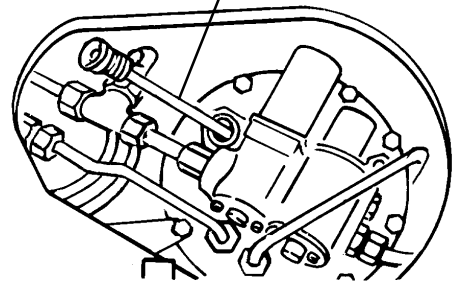
yes

no

Charge main accumulator assembly nitrogen (para 19-4). If malfunction persists, notify support maintenance.

CONTINUED ON NEXT PAGE

POWER  
PACK  
GAGE

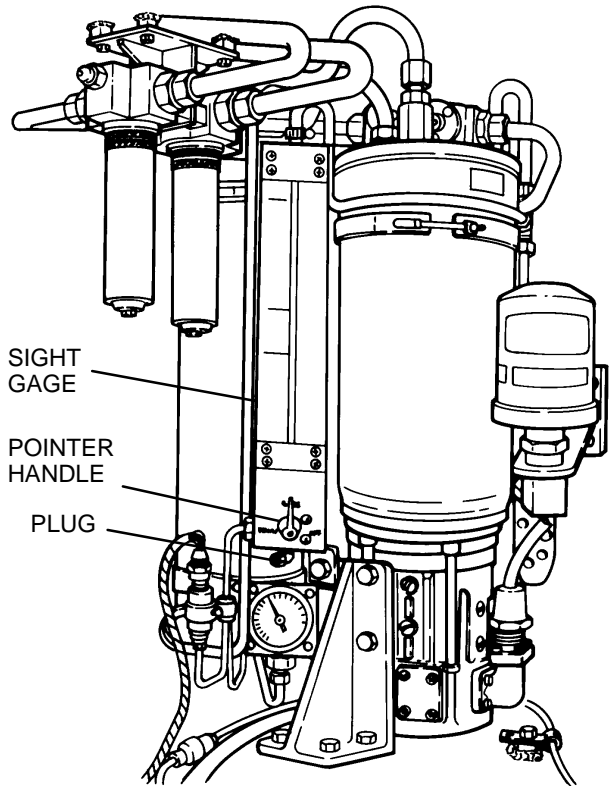
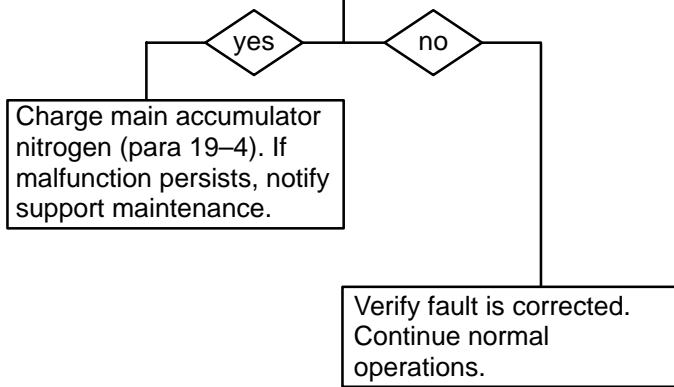


FULL AT 0 PRESSURE MARK

CONTINUED FROM STEP A

- B**
1. Place utility pail under sight gage drain.
  2. Drain hydraulic fluid by removing plug and turning pointer handle to DRAIN position.
  3. Check hydraulic fluid in tube on sight gage.
  4. Close drain when hydraulic fluid reaches FULL AT 0 PRESSURE mark.
  5. Verify hydraulic fluid level by checking power pack gage.
  6. Fully charge hydraulic system (para 6-3).
  7. Discharge pressure in hydraulic system (para 6-3).

Does fluid overflow from top of sight gage?



END OF TASK



### 3-3 TROUBLESHOOTING — CONTINUED

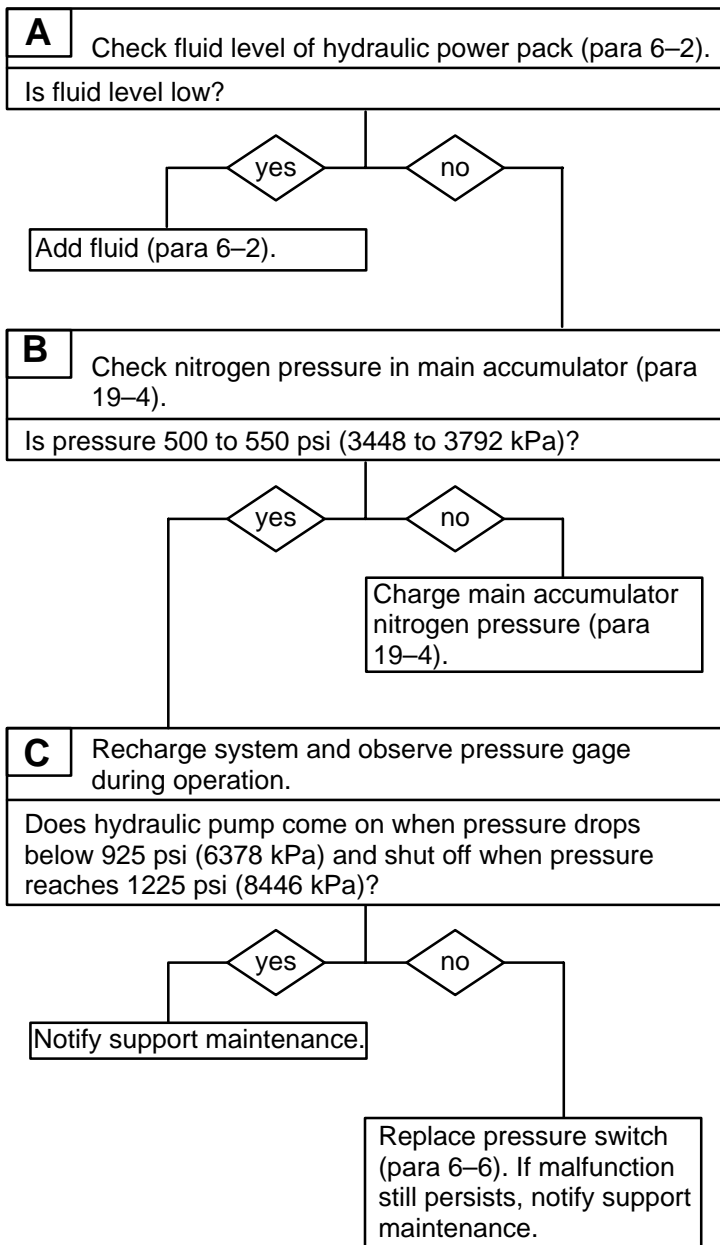
e. CAB HYDRAULIC SYSTEM — CONTINUED

(4) HYDRAULIC PUMP MOTOR ON/OFF CYCLE IS RAPID.

#### INITIAL SETUP

Tools

Artillery and turret mechanic's tool kit  
(SC 5180-95-CL-A12)



**END OF TASK**

e. CAB HYDRAULIC SYSTEM — CONTINUED

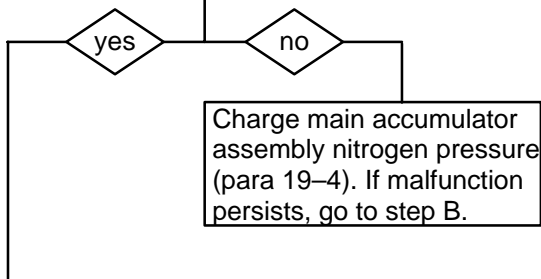
- (5) POWER PACK OPERATES CONTINUOUSLY WHEN CAB POWER AND MASTER SWITCHES ARE ON.

**INITIAL SETUP**

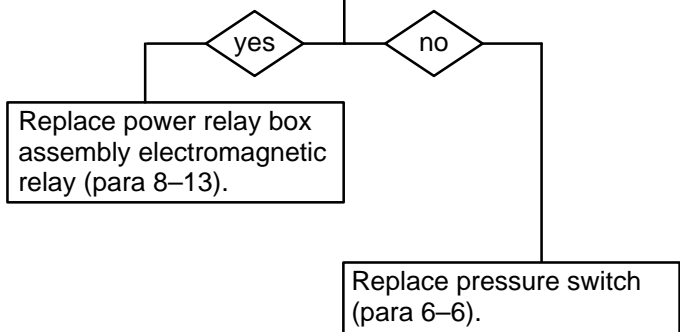
**Tools**

Artillery and turret mechanic's tool kit  
(SC 5180-95-CL-A12)

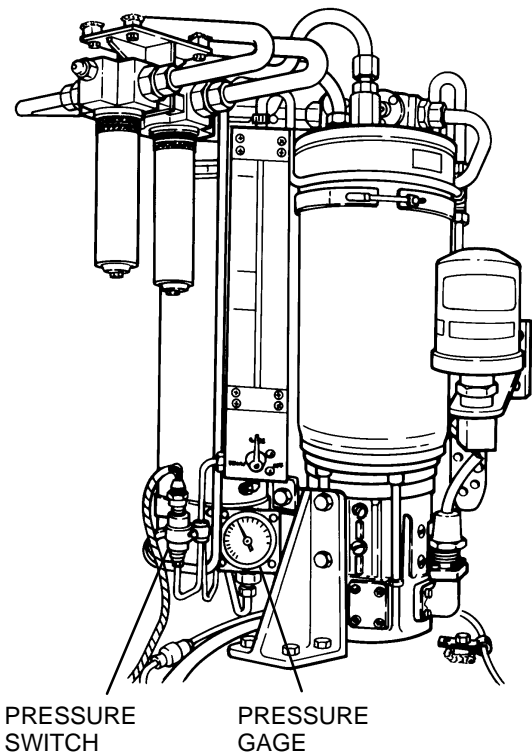
**A** Perform zero-pressure check (para 6-10) on main accumulator assembly.  
Is pressure 500 to 550 psi (3448 to 3792 kPa)?



**B** 1. Turn MASTER and CAB POWER switches to OFF.  
2. Disconnect cannon plug at pressure switch.  
3. Turn MASTER and CAB POWER switches to ON.  
4. Observe power pack operation.  
5. Turn MASTER and CAB POWER switches to OFF.  
Did power pack operate continuously?



**END OF TASK**



3-3 TROUBLESHOOTING — CONTINUED

e. CAB HYDRAULIC SYSTEM — CONTINUED

(6) GUNNER'S OR ASSISTANT GUNNER'S CONTROL HANDLE DOES NOT RETURN TO NEUTRAL POSITION WHEN RELEASED.

**INITIAL SETUP**

Tools

Artillery and turret mechanic's tool kit  
(SC 5180-95-CL-A12)

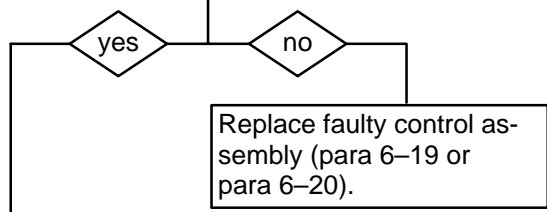
Materials/Parts

Hydraulic fluid (OHT) (item 21, Appx D)

Equipment Condition

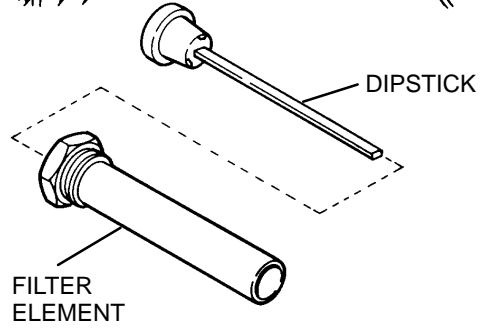
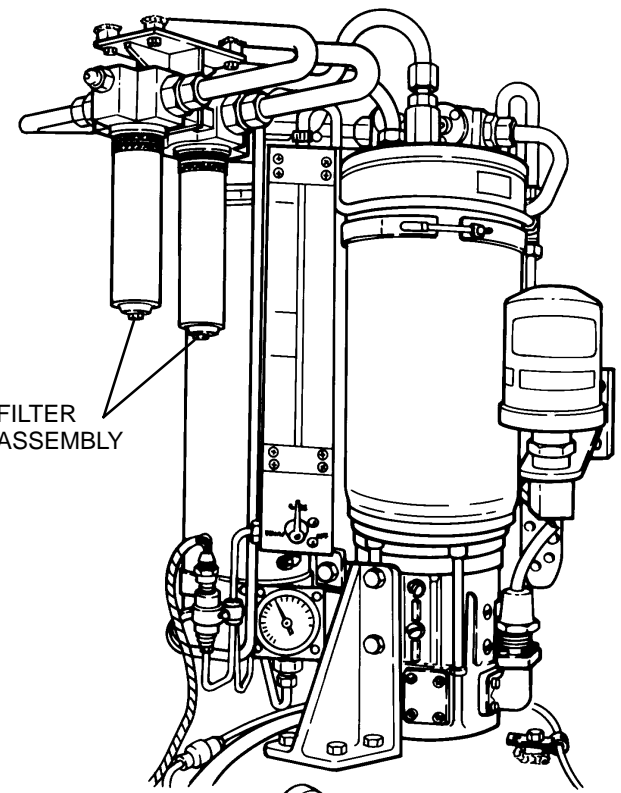
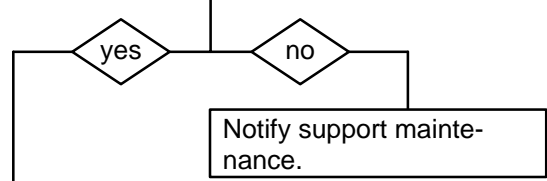
Discharge hydraulic pressure (para 6-3)

**A** Turn MASTER and CAB POWER switches to OFF.  
Did gunner's or assistant gunner's control handle return to neutral position?



**NOTE**  
Step B applies only to M109A4/M109A5 howitzers. Proceed to step C for M109A2/M109A3 howitzers.

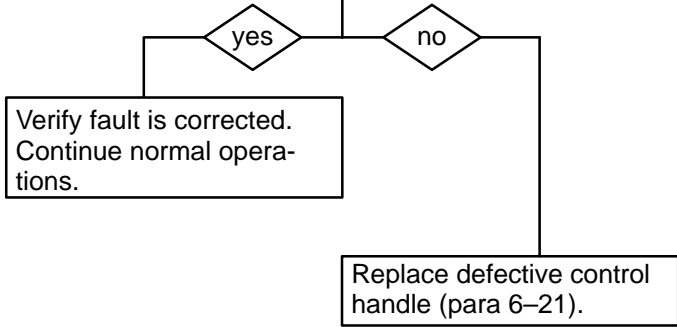
**B** Ensure hydraulic filter assembly indicators are in bypass mode to check for foreign matter in hydraulic fluid.  
Is foreign matter present?



CONTINUED ON NEXT PAGE

CONTINUED FROM STEP B

<b>C</b>	<ol style="list-style-type: none"> <li>1. Drain system and discard fluid (para 6-3).</li> <li>2. Clean strainer (para 6-4).</li> <li>3. Replace filter elements (M109A4/M109A5 howitzers only) (para 6-17).</li> <li>4. Fill and charge hydraulic system (para 6-3).</li> <li>5. Turn MASTER and CAB POWER switches to ON.</li> <li>6. Operate gunner's or assistant gunner's control handle.</li> </ol>
Does handle return to neutral position when released?	



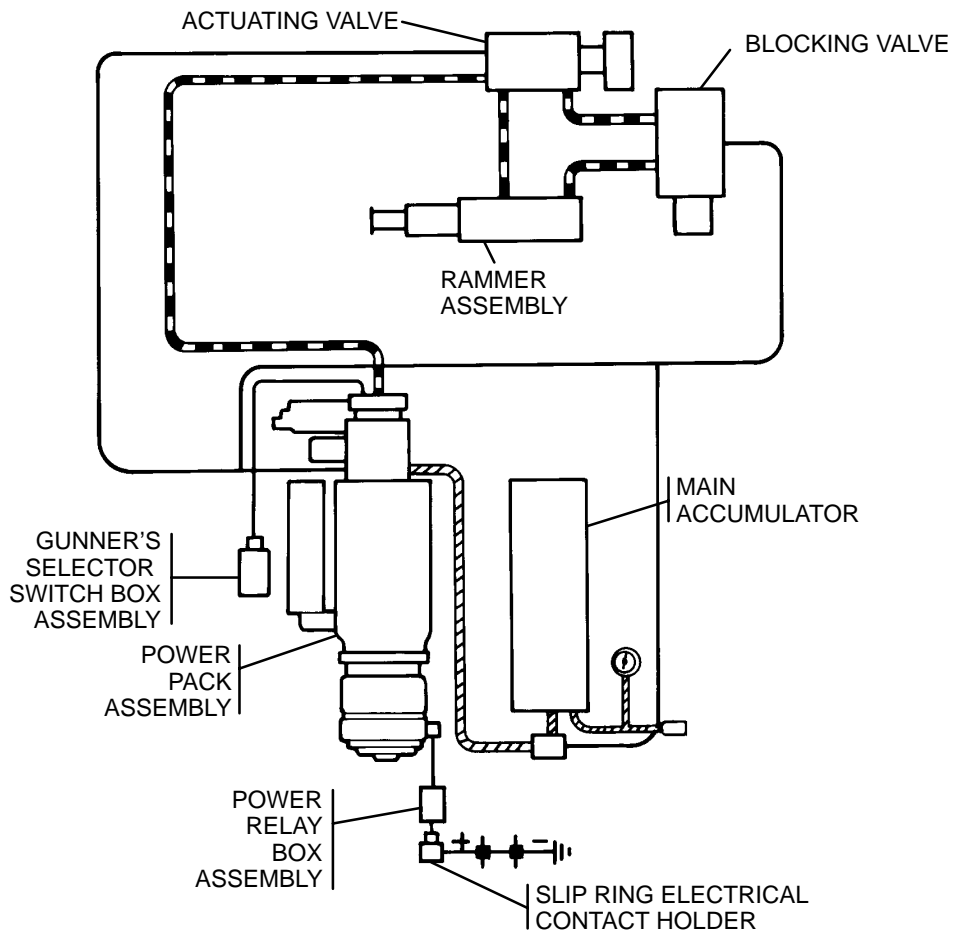
**END OF TASK**

### 3-3 TROUBLESHOOTING — CONTINUED


#### f. RAMMER HYDRAULIC SYSTEM


The rammer hydraulic system consists of the rammer, actuating valve, tray assembly, rammer cylinder, main release handle, cylinder handle assembly, cylinder latch, and the blocking valve.

The rammer is used for loading and ramming the projectile into the tube. Hydraulic power from the power pack supplies the pressure to the rammer cylinder which rams the projectile into position. Normal hydraulic pressure is between 925 to 1225 psi (6378 to 8446 kPa). The rammer actuating valve controls the inflow of hydraulic fluid for the ramming operation and outflow of hydraulic fluid for the retraction of the rammer after use. The tray assembly holds the projectile in position for ramming while the cylinder latch locks the rammer cylinder into position on the tray assembly. The rammer cylinder contains a piston which rams the projectile into the chamber. The main release handle releases the locking mechanism so that the rammer may be moved into RAM position, and also back into STOW position. The cylinder handle assembly provides a hand hold for rotating the rammer cylinder into ramming position. The blocking valve prevents accidental ramming of rammer in stowed position.



  
 OPERATING  
 PRESSURE  
 900 PSI  
 (6206 kPa)

  
 DRAIN  
 RESERVOIR  
 PRESSURE  
 0 PSI (0 kPa)

  
 PUMP PRES-  
 SURE  
 925-1225 PSI  
 (6378-8446 kPa)

f. RAMMER HYDRAULIC SYSTEM — CONTINUED

(1) RAMMER DOES NOT OPERATE.

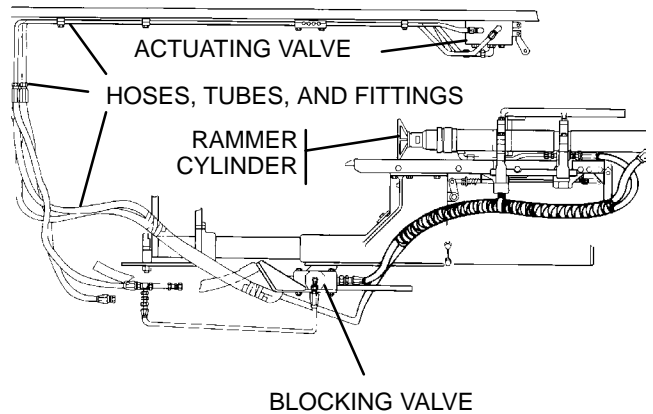
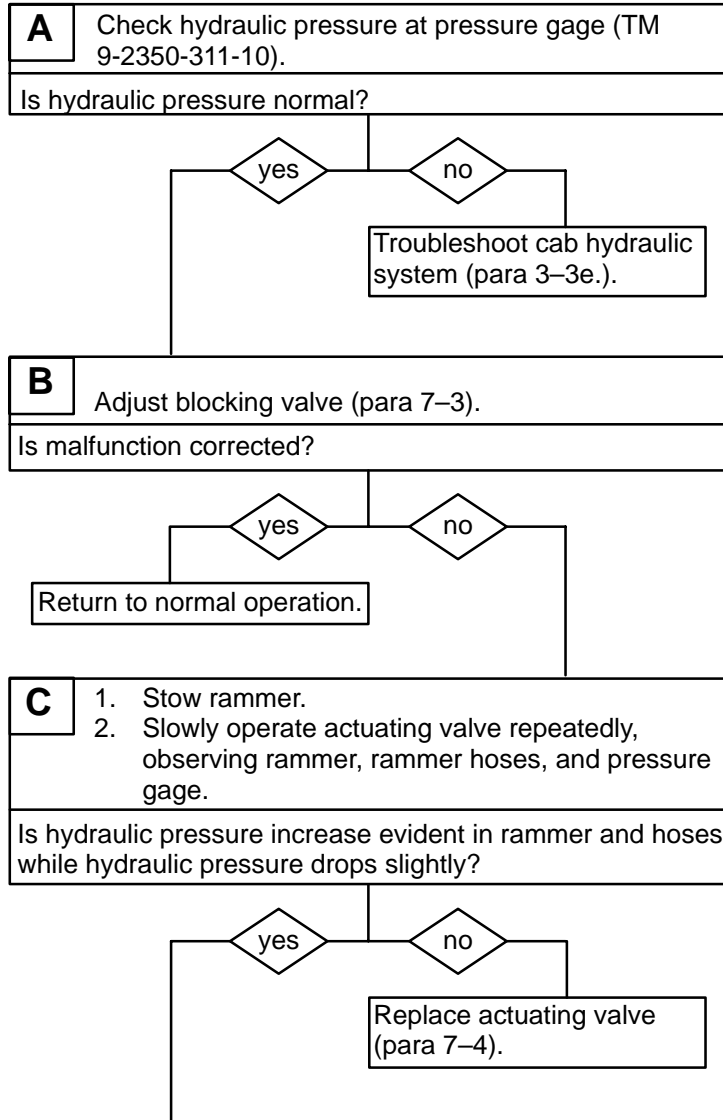
**INITIAL SETUP**

Tools

Artillery and turret mechanic's tool kit  
(SC 5180-95-CL-A12)

Equipment Condition

Vehicle MASTER switch to ON (TM 9-2350-311-10)  
CAB POWER switch to ON (TM 9-2350-311-10)



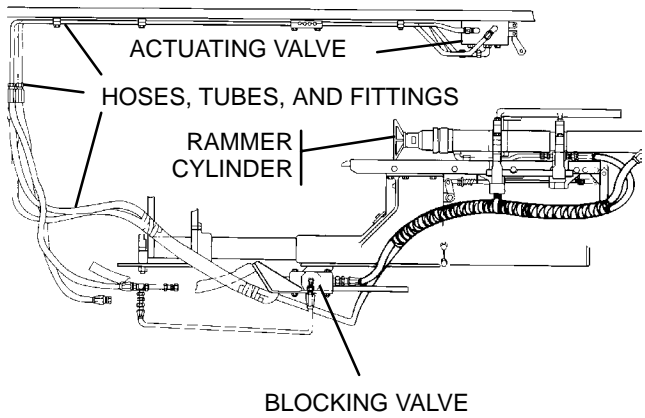
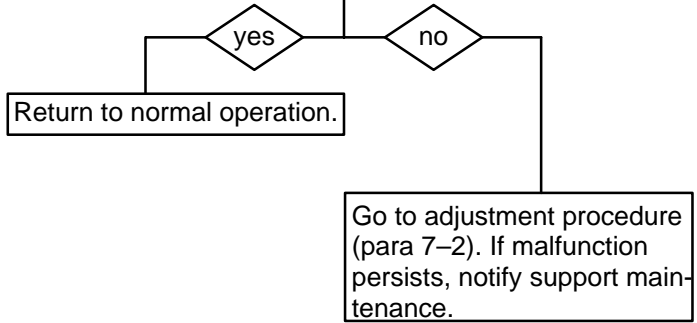
CONTINUED ON NEXT PAGE

f. RAMMER HYDRAULIC SYSTEM — CONTINUED

(1) RAMMER DOES NOT OPERATE.  
— CONTINUED

CONTINUED FROM STEP C

- D**
1. Replace blocking valve (para 7-2).
  2. Extend rammer and check alinement.
- Is adjustment correct?



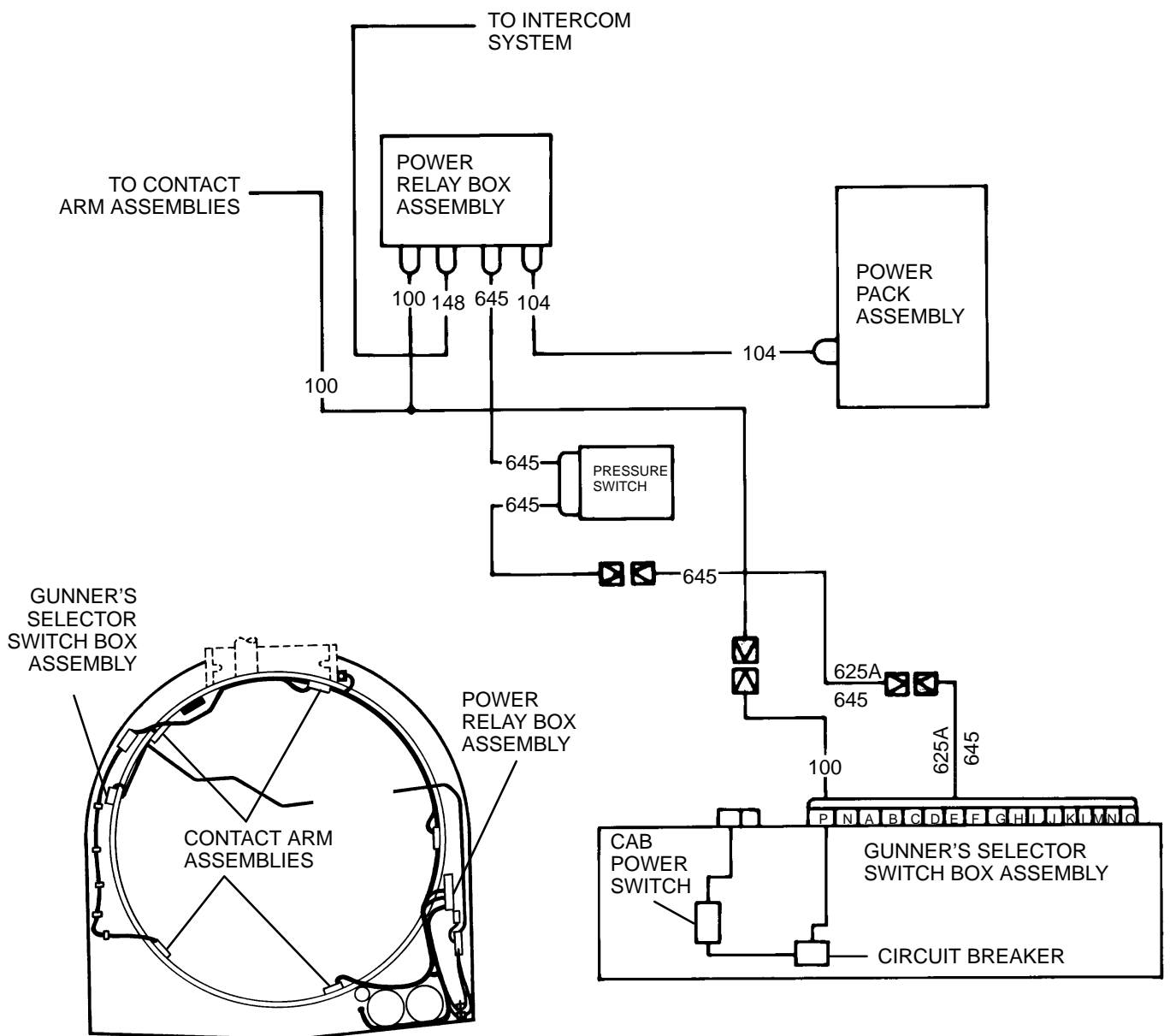
END OF TASK

**3-3 TROUBLESHOOTING — CONTINUED**

**g. CAB POWER SYSTEM**

The cab power system consists of the slip ring, contact arm assemblies, and gunner's selector switch box assembly. The internal gunner's selector switch box assembly components that relate to the cab power system are the CAB POWER switch and the CAB POWER indicator light.

Power is transferred from the hull to the cab through the slip ring and contact arm assemblies. This power is then distributed by wire 100 directly to various cab systems such as cab lighting and NBC. These systems will operate with the CAB POWER switch in the OFF position. Other systems receive power through the CAB POWER switch. These systems include elevating, cab traversing, and cab hydraulics.





g. CAB POWER SYSTEM — CONTINUED

(1) ALL CAB ELECTRICAL COMPONENTS FAIL TO OPERATE.

**INITIAL SETUP**

Test Equipment

Multimeter (item 6, Appx H)

Tools

Artillery and turret mechanic's tool kit  
(SC 5180-95-CL-A12)

References

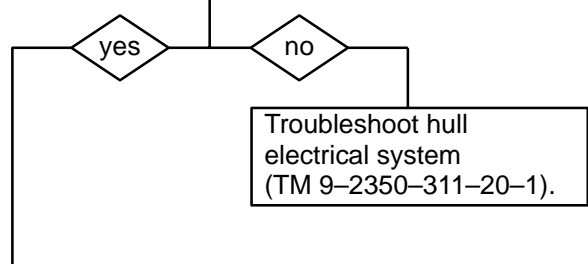
TM 9-2350-311-20-1

Equipment Condition

Vehicle MASTER switch to ON (TM 9-2350-311-10)  
CAB POWER switch to OFF (TM 9-2350-311-10)

**A** 1. Place red multimeter lead to wire 47 terminal at the segment board and black lead to ground.  
2. Check for voltage.

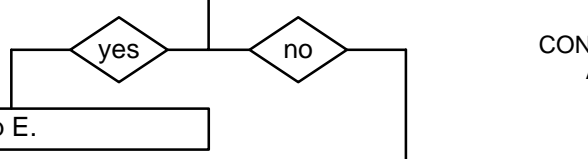
Is battery voltage present?



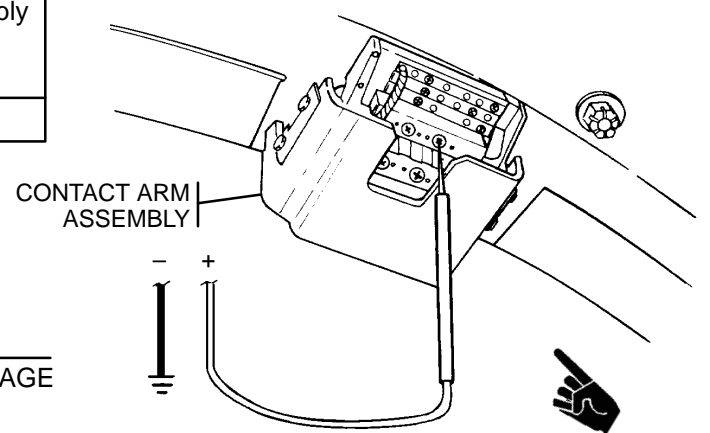
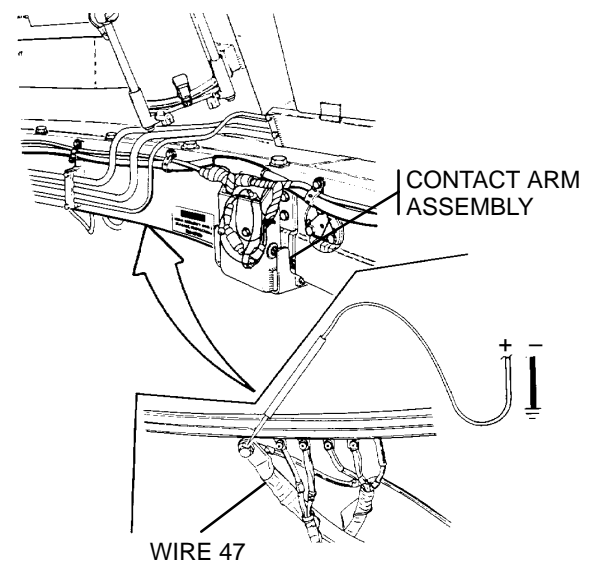
**NOTE**  
Steps B through D must be repeated for each contact arm assembly in contact with segment.

**B** 1. Place red multimeter lead to screw (use either of two screws) on bottom of contact arm assembly and black lead to ground.  
2. Check for voltage.

Is battery voltage present?



CONTINUED ON NEXT PAGE



3-3 TROUBLESHOOTING — CONTINUED

g. CAB POWER SYSTEM — CONTINUED

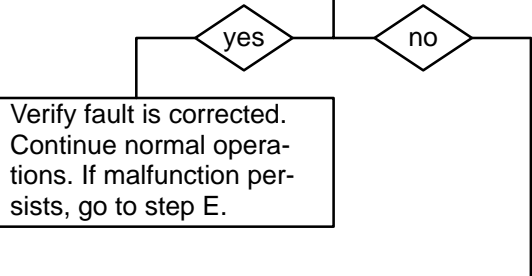
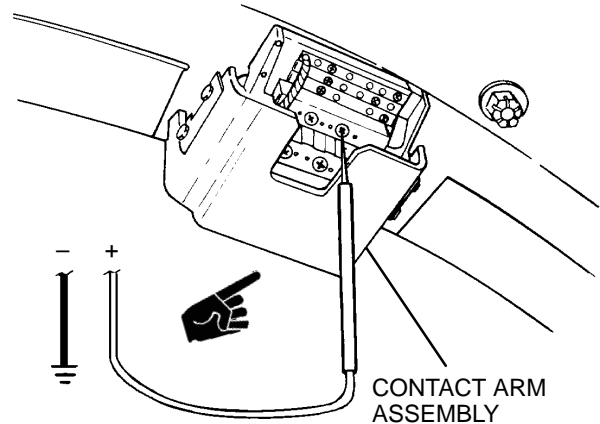
(1) ALL CAB ELECTRICAL COMPONENTS FAIL TO OPERATE. — CONTINUED

CONTINUED FROM STEP B

**C**

1. Turn MASTER switch to OFF.
2. Inspect electrical contact brushes for wear and adjust contact arm assembly (para 9-3).
3. Turn MASTER switch to ON.
4. Place red multimeter lead to screw (use either of two screws) on bottom of contact arm assembly and black lead to ground.
5. Check for voltage.

Is battery voltage present?

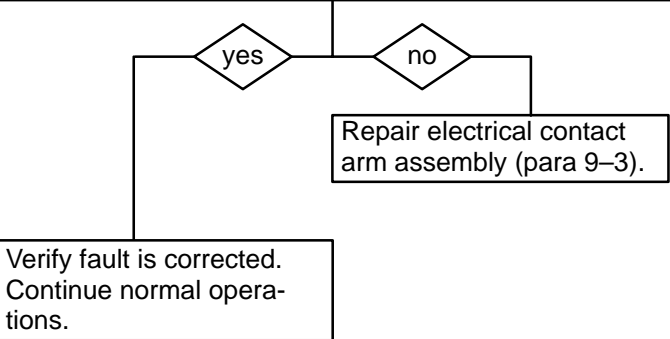
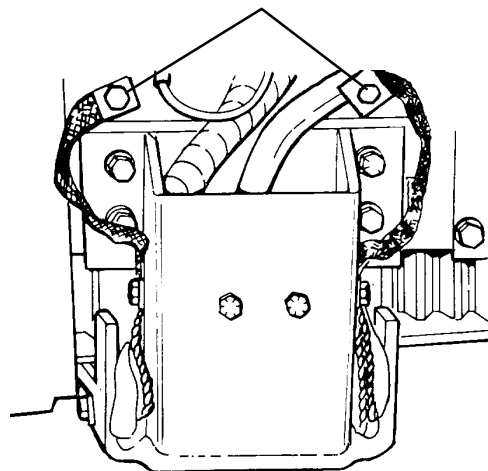


**D**

1. Check ground strap attaching cap screws for proper connection.
2. Place red multimeter lead to screw (use either of two screws) on bottom of contact arm assembly and black lead to ground.
3. Check for voltage.

Is battery voltage present?

GROUND STRAP CONNECTION

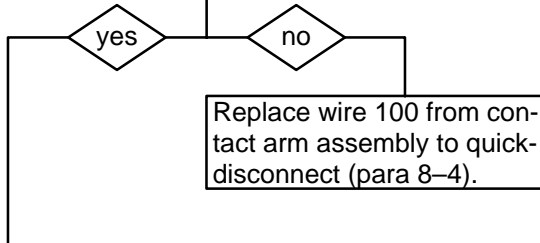


CONTINUED ON NEXT PAGE

CONTINUED FROM STEP B

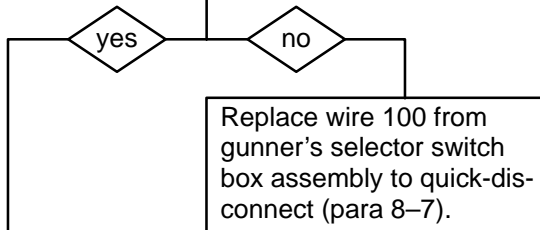
- E**
1. Turn MASTER switch to OFF.
  2. Disconnect wire 100 from quick-disconnect at gunner's selector switch box assembly.
  3. Turn MASTER switch to ON.
  4. Place red multimeter lead in wire 100 quick-disconnect leading to contact arm assembly and black lead to ground.
  5. Check for voltage.

Is battery voltage present?

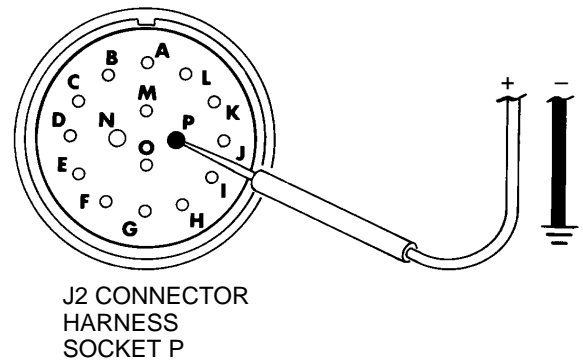
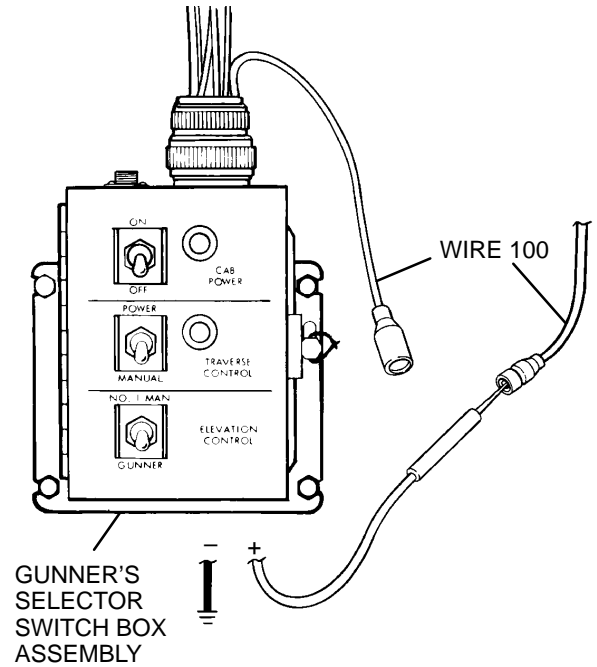


- F**
1. Turn MASTER switch to OFF.
  2. Reconnect wire 100 to quick-disconnect at gunner's selector switch box assembly.
  3. Disconnect J2 harness connector of gunner's selector switch box assembly.
  4. Turn MASTER switch to ON.
  5. Place red multimeter lead at socket P of J2 harness connector and black lead to ground.
  6. Check for voltage.

Is battery voltage present?



CONTINUED ON NEXT PAGE



3-3 TROUBLESHOOTING — CONTINUED

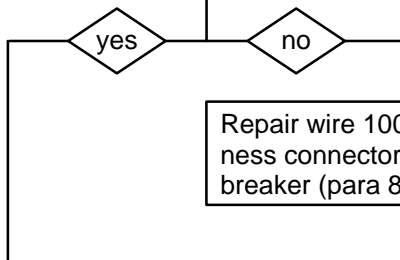
g. CAB POWER SYSTEM — CONTINUED

(1) ALL CAB ELECTRICAL COMPONENTS FAIL TO OPERATE. — CONTINUED

CONTINUED FROM STEP F

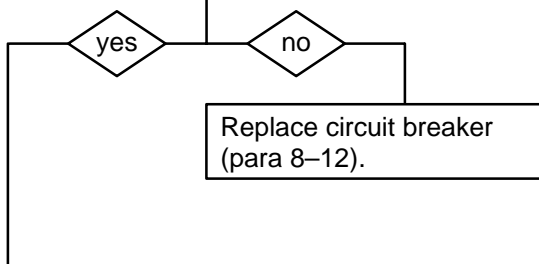
- G**
1. Turn MASTER switch to OFF.
  2. Reconnect J2 harness connector at gunner's selector switch box assembly.
  3. Open gunner's selector switch box assembly.
  4. Turn MASTER switch to ON.
  5. Place red multimeter lead on circuit breaker input terminal A and black lead to ground.
  6. Check for voltage.

Is battery voltage present?



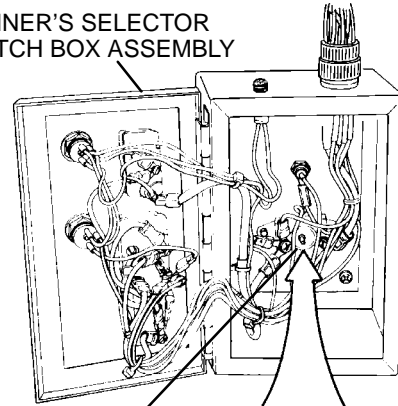
- H**
1. Place red multimeter lead on circuit breaker output terminal B and black lead to ground.
  2. Check for voltage.

Is battery voltage present?

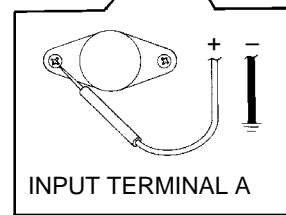


CONTINUED ON NEXT PAGE

GUNNER'S SELECTOR SWITCH BOX ASSEMBLY

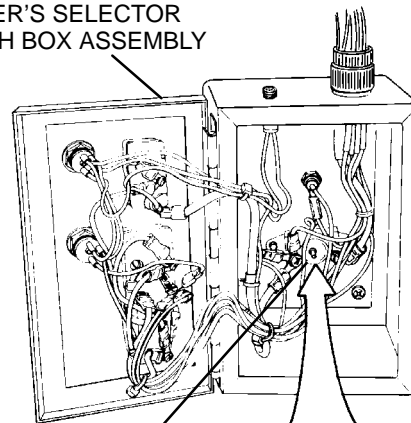


CIRCUIT BREAKER

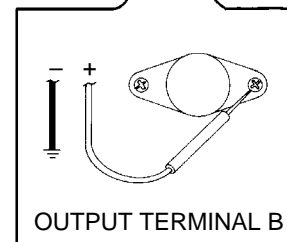


INPUT TERMINAL A

GUNNER'S SELECTOR SWITCH BOX ASSEMBLY



CIRCUIT BREAKER



OUTPUT TERMINAL B

CONTINUED FROM STEP H

**I** 1. Place red multimeter lead on input terminal 3 of CAB POWER switch and black lead to ground.  
2. Check for voltage.

Is battery voltage present?



Replace wire from CAB POWER switch to circuit breaker (para 8-12).

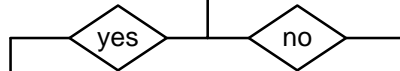
**J** 1. Turn CAB POWER switch to ON.  
2. Place red multimeter lead on output terminal 2 of CAB POWER switch and black lead to ground.  
3. Check for voltage.

Is battery voltage present?



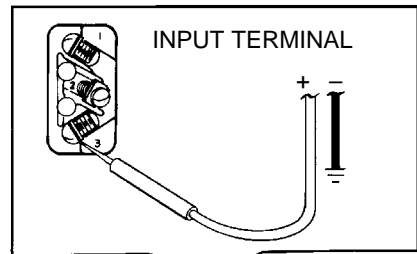
Replace CAB POWER switch (para 8-12).

**K**

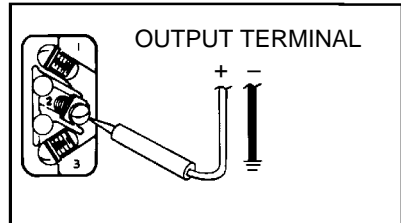
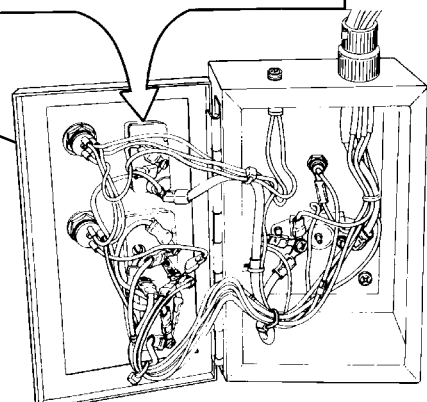


Troubleshoot elevation and traversing system.

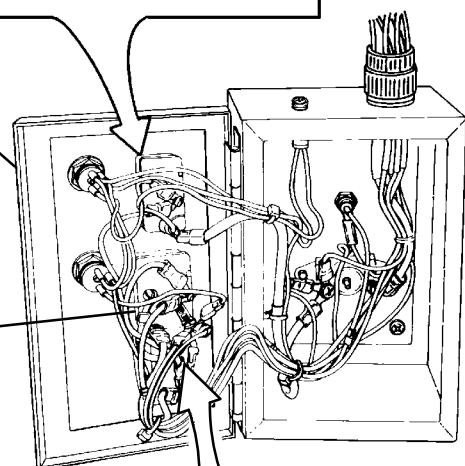
Replace wire from CAB POWER switch to ELEVATION CONTROL switch (para 8-12).



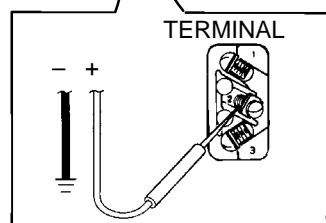
CAB POWER SWITCH



CAB POWER SWITCH



ELEVATION CONTROL SWITCH



END OF TASK

**3-3 TROUBLESHOOTING — CONTINUED**

g. CAB POWER SYSTEM — CONTINUED

(2) CAB ELECTRICAL COMPONENTS OPERATE NORMALLY, BUT CAB POWER INDICATOR LIGHT DOES NOT ILLUMINATE.

**INITIAL SETUP**

Test Equipment

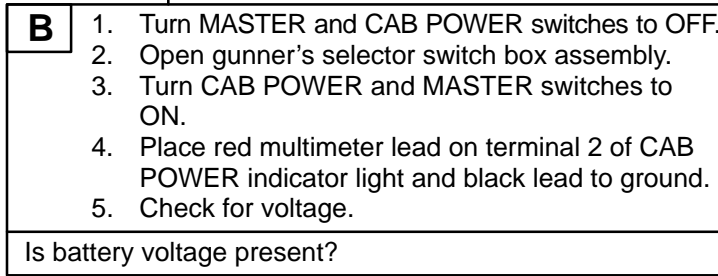
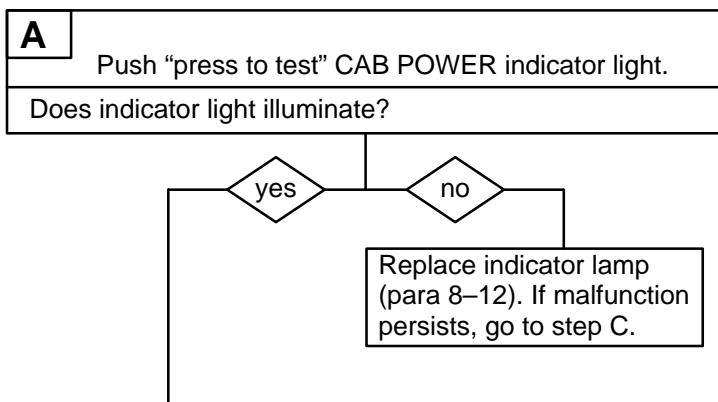
Multimeter (item 6, Appx H)

Tools

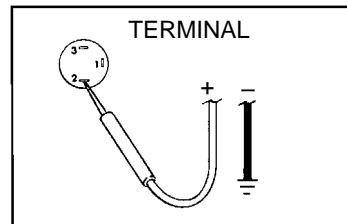
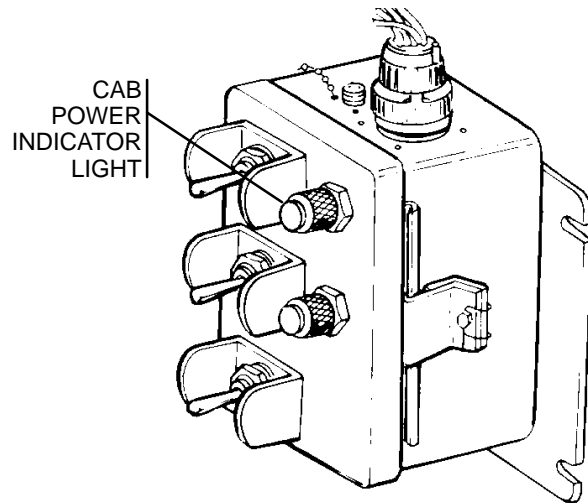
Artillery and turret mechanic's tool kit  
(SC 5180-95-CL-A12)

Equipment Condition

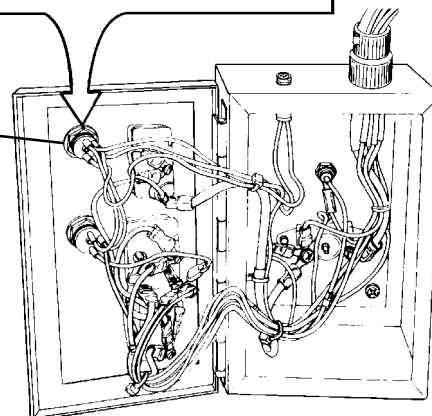
Vehicle MASTER switch to ON (TM 9-2350-311-10)  
CAB POWER switch to ON (TM 9-2350-311-10)



CONTINUED ON NEXT PAGE



CAB POWER INDICATOR LIGHT



CONTINUED FROM STEP A OR B

- C**
1. Turn CAB POWER and MASTER switches to OFF.
  2. Place one multimeter lead on terminal 1 of CAB POWER indicator light and other lead to ground.
  3. Check for continuity.
- Is continuity present?

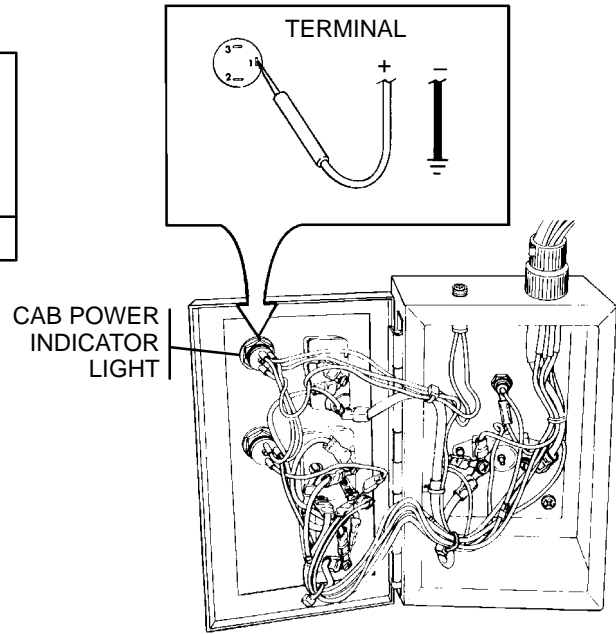
yes

no

Replace indicator light (para 8-12).

Repair ground circuit from terminal 1 of CAB POWER indicator light (para 8-12).

END OF TASK



### 3-3 TROUBLESHOOTING — CONTINUED

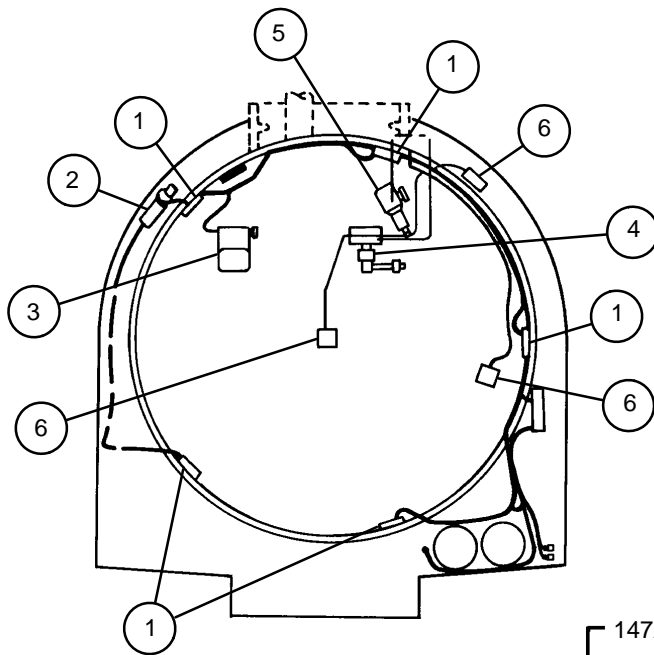
#### h. CAB LIGHTING SYSTEM

The cab lighting system consists of three dome light assemblies and internal lighting for the M15 elevation quadrant, M117/M117A2 panoramic telescope, and M118A2/M118A3 elbow telescope.

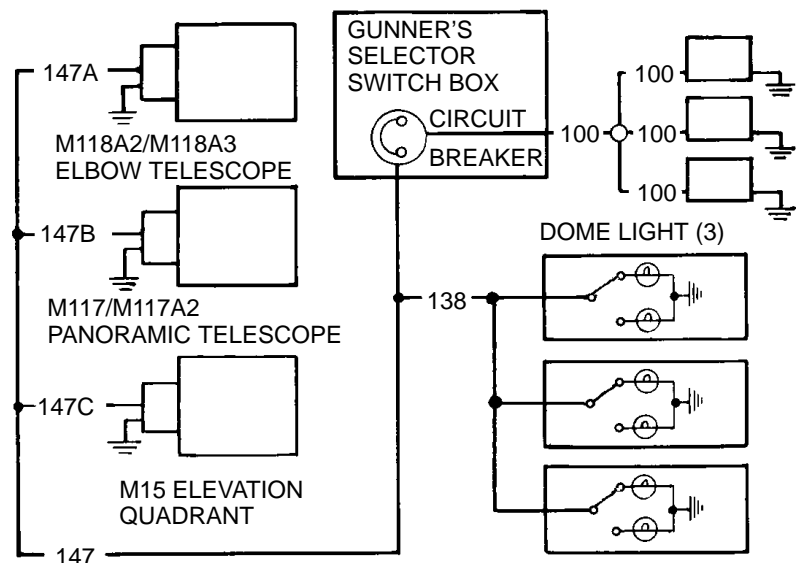
Power for these lighting components is routed from the contact arm assemblies through the gunner's selector switch box assembly.

**LEGEND:**

- |  |                                  |
|--|----------------------------------|
| 1. Electrical contact arm assemblies     | 4. M118A2/M118A3 elbow telescope |
| 2. Gunner's selector switch box assembly | 5. M15 elevation quadrant        |
| 3. M117/M117A2 panoramic telescope       | 6. Dome light assemblies         |



PICTORIAL VIEW



ELECTRICAL DIAGRAM



h. CAB LIGHTING SYSTEM — CONTINUED

- (1) ONE OR MORE DOME LIGHTS ARE OUT, BUT SIGHTING EQUIPMENT LIGHTS OPERATE.

**INITIAL SETUP**

Test Equipment

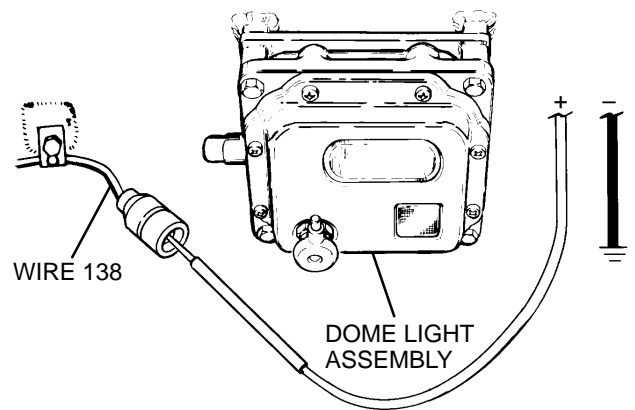
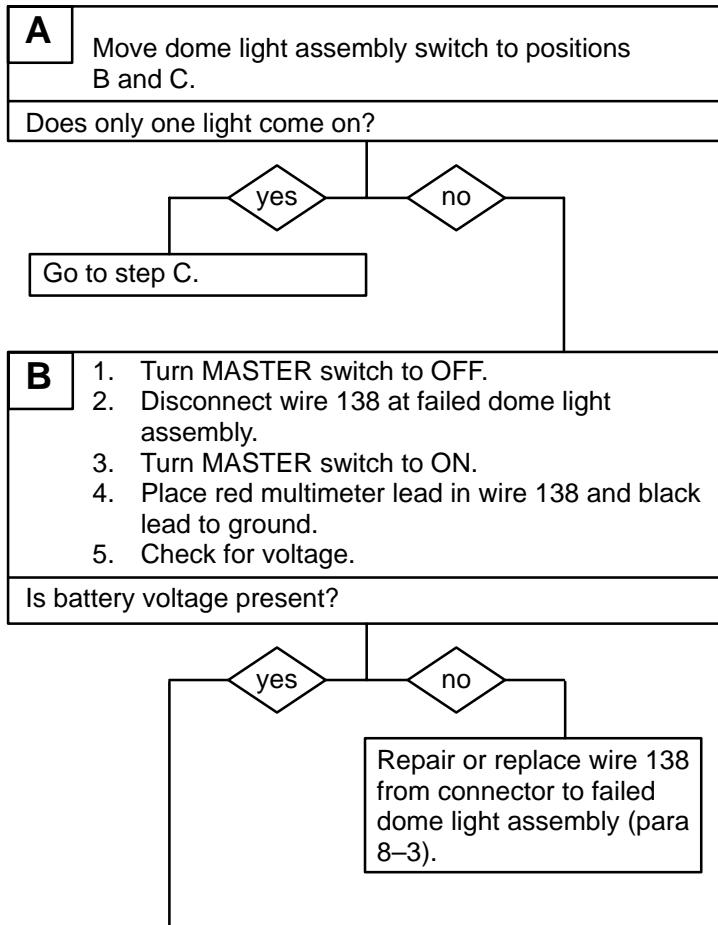
Multimeter (item 6, Appx H)

Tools

Artillery and turret mechanic's tool kit  
(SC 5180-95-CL-A12)

Equipment Condition

Vehicle MASTER switch to ON (TM 9-2350-311-10)  
Dome light assembly switch to position A  
(TM 9-2350-311-10)



CONTINUED ON NEXT PAGE

3-3 TROUBLESHOOTING — CONTINUED

h. CAB LIGHTING SYSTEM — CONTINUED

(1) ONE OR MORE DOME LIGHTS ARE OUT, BUT SIGHTING EQUIPMENT LIGHTS OPERATE. — CONTINUED

CONTINUED FROM STEP A OR B

**C**

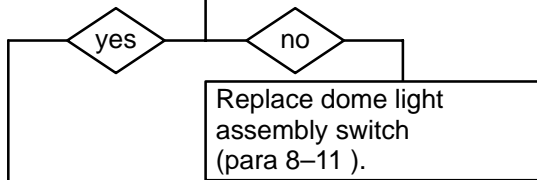
1. Turn MASTER switch to OFF.
2. Reconnect wire 138 to dome light assembly if disconnected.
3. Remove cover from faulty dome light assembly (para 8-11).
4. Turn MASTER switch to ON.

**NOTE**

Dome light assembly switch must be placed in position B for blue (blackout) light output terminal "R", then position C for white light output terminal "W".

5. Place red multimeter lead to dome light assembly switch output terminals (R, then W) and black lead to ground.
6. Check for voltage.

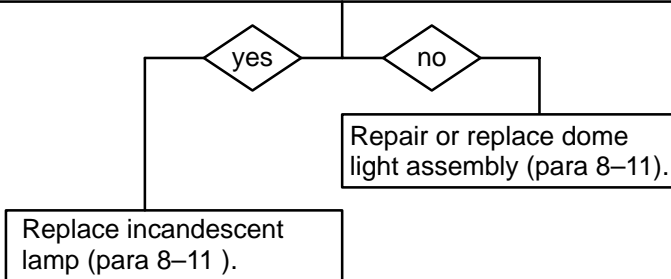
Is battery voltage present in both positions?



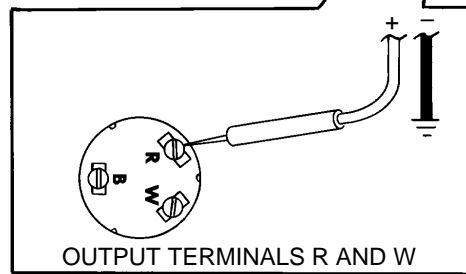
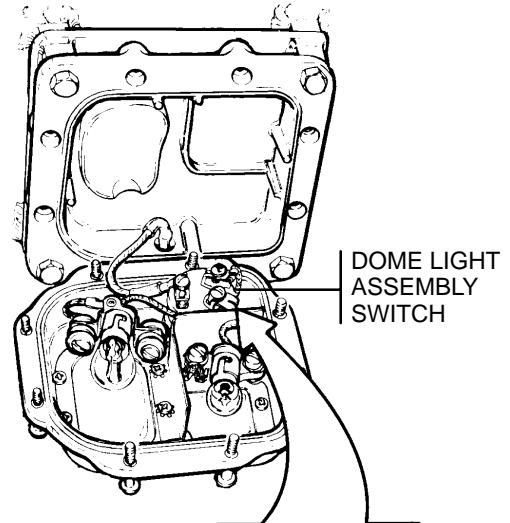
**D**

1. Turn MASTER switch to OFF.
2. Remove incandescent lamp from failed socket assembly.
3. Place red multimeter lead on contact in center of socket and black lead to ground.
4. Turn MASTER switch to ON.
5. Turn dome light switch to the position of the failed socket assembly.
6. Check for voltage.

Is battery voltage present?



END OF TASK



h. CAB LIGHTING SYSTEM — CONTINUED

(2) M118A2/M118A3 ELBOW TELESCOPE LIGHT IS OUT, BUT ALL OTHER LIGHTS OPERATE.

**INITIAL SETUP**

Test Equipment

Multimeter (item 6, Appx H)

Tools

Artillery and turret mechanic's tool kit  
(SC 5180-95-CL-A12)

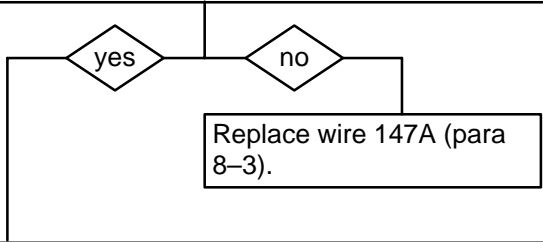
Equipment Condition

Vehicle MASTER switch to OFF (TM 9-2350-311-10)

**A**

1. Disconnect wire 147A at M146 mount.
2. Turn MASTER switch to ON.
3. Place red multimeter lead in each socket of wire 147A and black lead to ground.
4. Check for voltage.

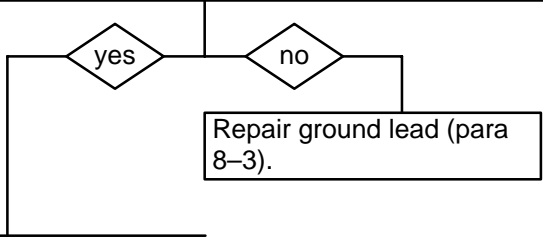
Is battery voltage present at one socket only?



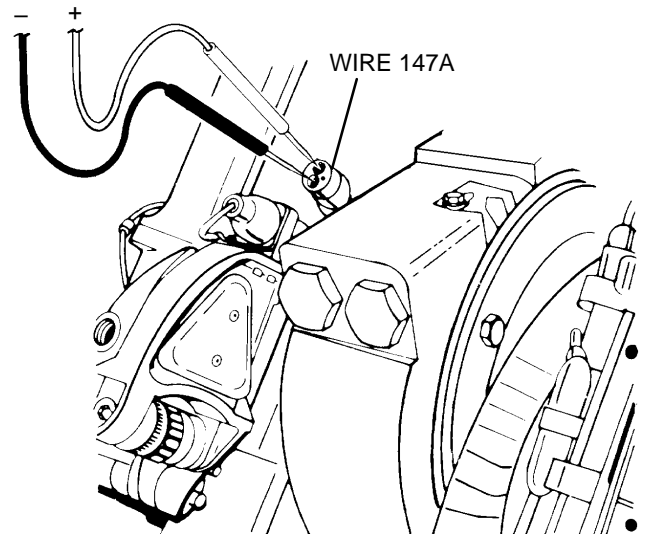
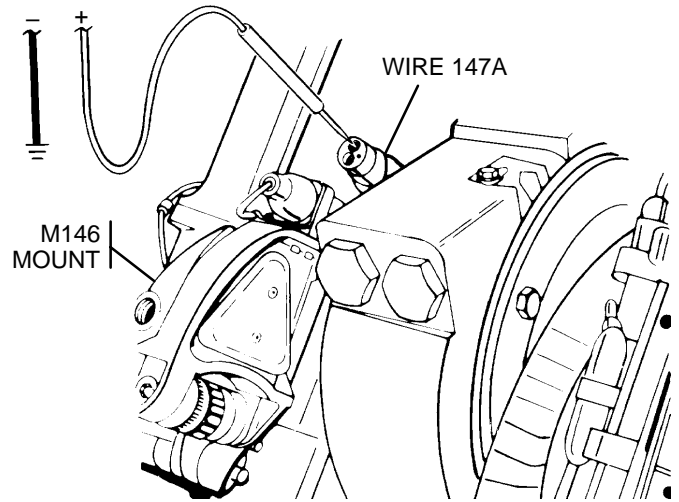
**B**

1. Check ground lead for good connection.
2. Place red multimeter lead in one socket and black lead in ground socket of wire 147A.
3. Check for voltage.

Is battery voltage present?



CONTINUED ON NEXT PAGE



---

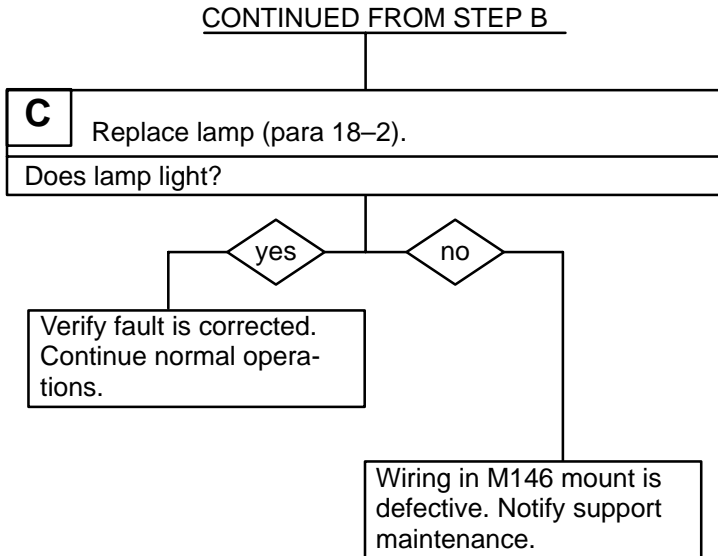
### 3-3 TROUBLESHOOTING — CONTINUED

---

h. CAB LIGHTING SYSTEM — CONTINUED

(2) M118A2/M118A3 ELBOW TELESCOPE LIGHT IS OUT, BUT ALL OTHER LIGHTS OPERATE. — CONTINUED

---



**END OF TASK**

h. CAB LIGHTING SYSTEM — CONTINUED

- (3) M145/M145A1 TELESCOPE MOUNT AND M117/M117A2 PANORAMIC TELESCOPE LIGHTS ARE OUT, BUT ALL OTHER LIGHTS OPERATE.

**INITIAL SETUP**

Test Equipment

Multimeter (item 6, Appx H)

Tools

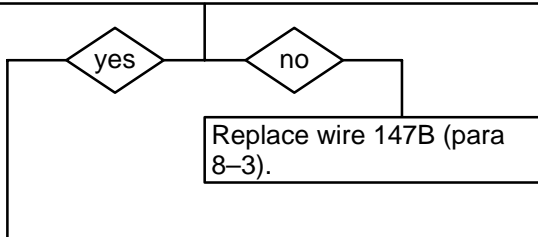
Artillery and turret mechanic's tool kit

(SC 5180-95-CL-A12)

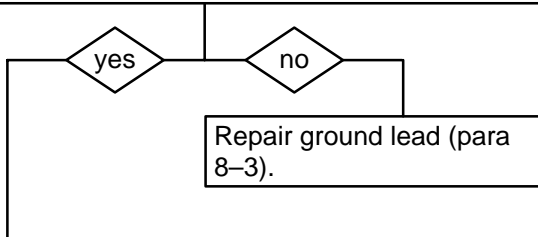
Equipment Condition

Vehicle MASTER switch to OFF (TM 9-2350-311-10)

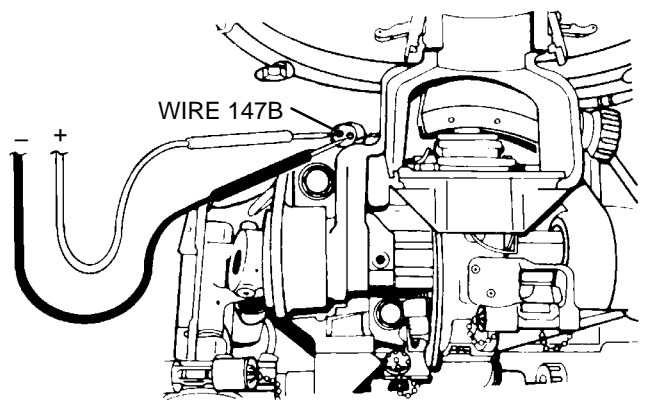
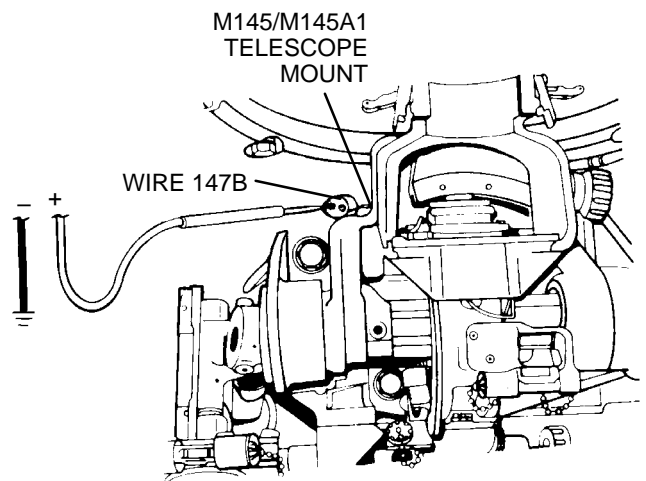
<b>A</b>	<ol style="list-style-type: none"> <li>1. Disconnect wire 147B at M145/M145A1 telescope mount.</li> <li>2. Turn MASTER switch to ON.</li> <li>3. Place red multimeter lead in each socket of wire 147B and black lead to ground.</li> <li>4. Check for voltage.</li> </ol>
Is battery voltage present at one socket only?	



<b>B</b>	<ol style="list-style-type: none"> <li>1. Check ground lead for good connection.</li> <li>2. Place red multimeter lead in one socket and black lead in ground socket of wire 147B.</li> <li>3. Check for voltage.</li> </ol>
Is battery voltage present?	



CONTINUED ON NEXT PAGE



---

### 3-3 TROUBLESHOOTING — CONTINUED

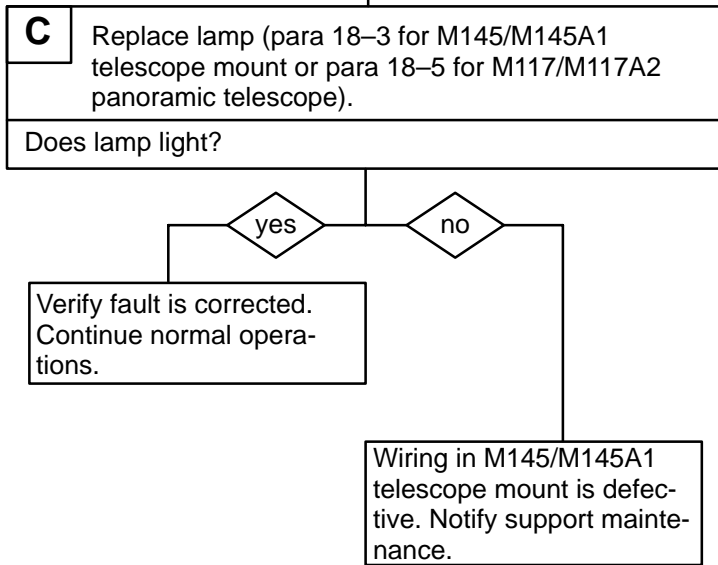
---

h. CAB LIGHTING SYSTEM — CONTINUED

(3) M145/M145A1 TELESCOPE MOUNT AND M117/M117A2 PANORAMIC TELESCOPE LIGHTS ARE OUT, BUT ALL OTHER LIGHTS OPERATE. — CONTINUED

---

CONTINUED FROM STEP B



**END OF TASK**

h. CAB LIGHTING SYSTEM — CONTINUED

(4) M15 ELEVATION QUADRANT LIGHT IS OUT, BUT ALL OTHER LIGHTS OPERATE.

**INITIAL SETUP**

Test Equipment

Multimeter (item 6, Appx H)

Tools

Artillery and turret mechanic's tool kit  
(SC 5180-95-CL-A12)

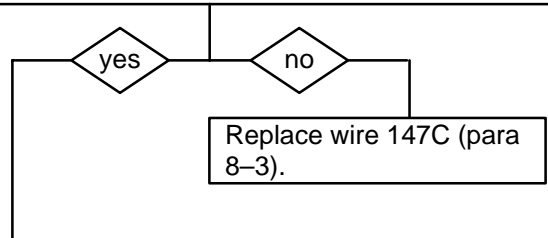
Equipment Condition

Vehicle MASTER switch to OFF (TM 9-2350-311-10)

**A**

1. Disconnect wire 147C at M15 quadrant.
2. Turn MASTER switch to ON.
3. Place red multimeter lead in each socket of wire 147C and black lead to ground.
4. Check for voltage.

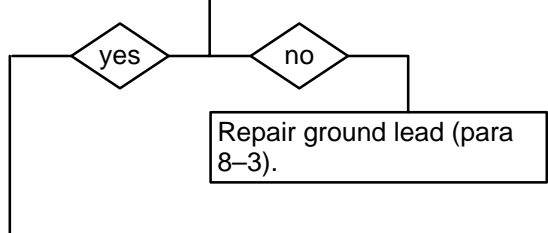
Is battery voltage present at one socket only?



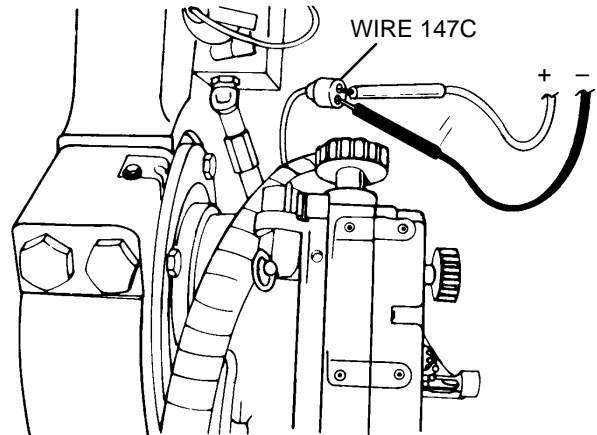
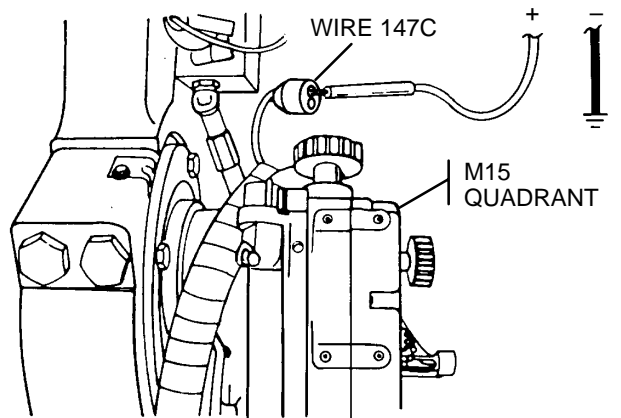
**B**

1. Check ground lead for good connection.
2. Place red multimeter lead in one socket connector and black lead in ground socket of wire 147C.
3. Check for voltage.

Is battery voltage present?



CONTINUED ON NEXT PAGE



---

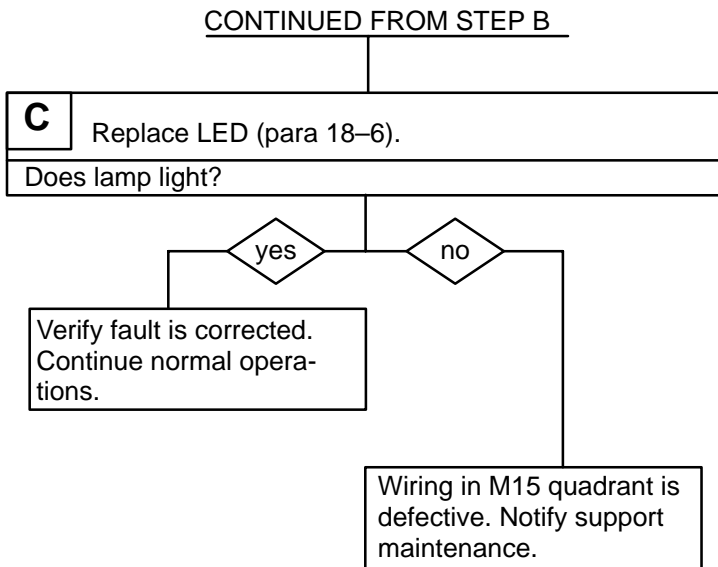
### 3-3 TROUBLESHOOTING — CONTINUED

---

h. CAB LIGHTING SYSTEM — CONTINUED

(4) M15 ELEVATION QUADRANT LIGHT IS OUT, BUT ALL OTHER LIGHTS OPERATE. — CONTINUED

---



**END OF TASK**



h. CAB LIGHTING SYSTEM — CONTINUED

(5) ALL CAB LIGHTS ARE OUT.

**INITIAL SETUP**

Test Equipment

Multimeter (item 6, Appx H)

Tools

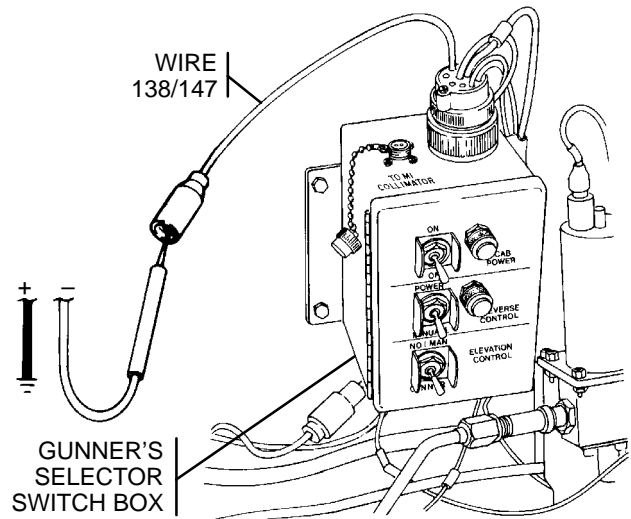
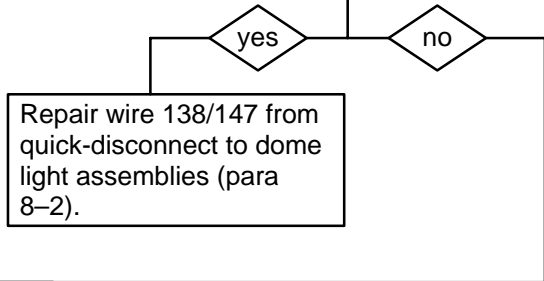
Artillery and turret mechanic's tool kit  
(SC 5180-95-CL-A12)

Equipment Condition

Vehicle MASTER switch to OFF (TM 9-2350-311-10)  
CAB POWER switch to OFF (TM 9-2350-311-10)

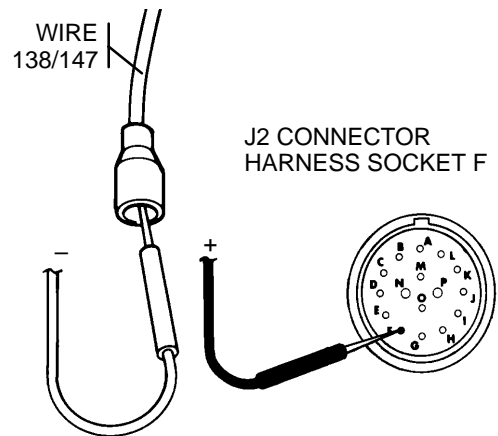
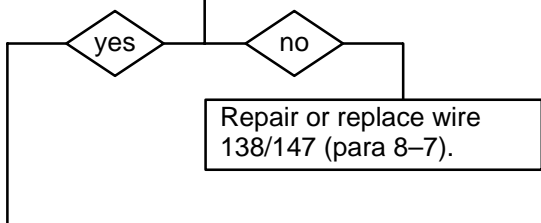
- A**
1. Disconnect wire 138/147 from quick-disconnect at gunner's selector switch box assembly.
  2. Turn MASTER and CAB POWER switches to ON.
  3. Place red multimeter lead in wire 138/147 quick-disconnect leading to gunner's selector switch box assembly and black lead to ground.
  4. Check for voltage.

Is battery voltage present?



- B**
1. Turn MASTER and CAB POWER switches to OFF.
  2. Disconnect harness from J2 connector at gunner's selector switch box assembly.
  3. Place one multimeter lead in quick-disconnect of wire 138/147 socket and other lead to socket F of J2 connector harness.
  4. Check for continuity.

Is continuity present?



CONTINUED ON NEXT PAGE

3-3 TROUBLESHOOTING — CONTINUED

h. CAB LIGHTING SYSTEM — CONTINUED

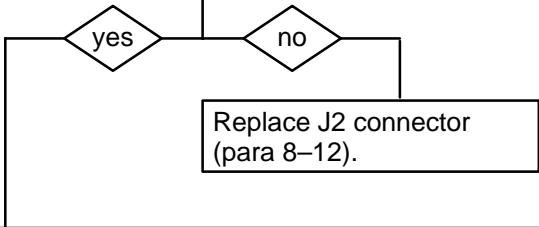
(5) ALL CAB LIGHTS ARE OUT. — CONTINUED

CONTINUED FROM STEP C

**C**

1. Reconnect wire 138/147 to quick-disconnect at gunner's selector switch box assembly.
2. Open gunner's selector switch box assembly.
3. Place one multimeter lead on output side of pin F of J2 connector and other lead on input side of pin F of J2 connector.
4. Check for continuity.

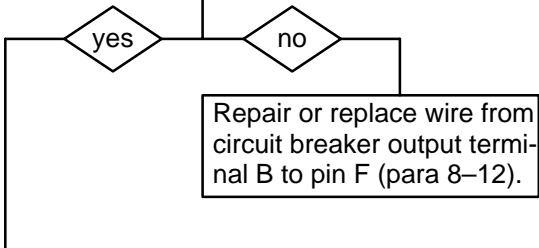
Is continuity present?



**D**

1. Place one multimeter lead on output side of pin F of J2 connector and other lead to output terminal B of circuit breaker.
2. Check for continuity.

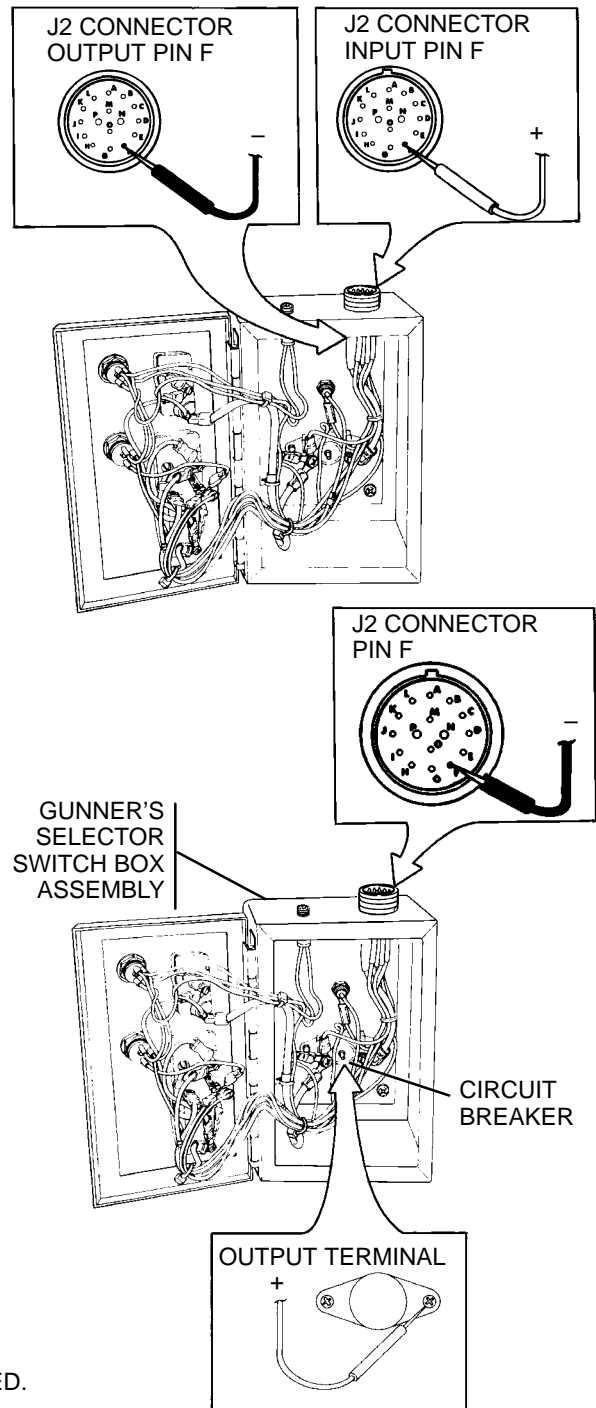
Is continuity present?



See troubleshooting chart para 3-3g. (1) .

END OF TASK

ALL INFORMATION ON PAGES 3-99 AND 3-100 HAS BEEN DELETED.



All data on this page has been deleted.

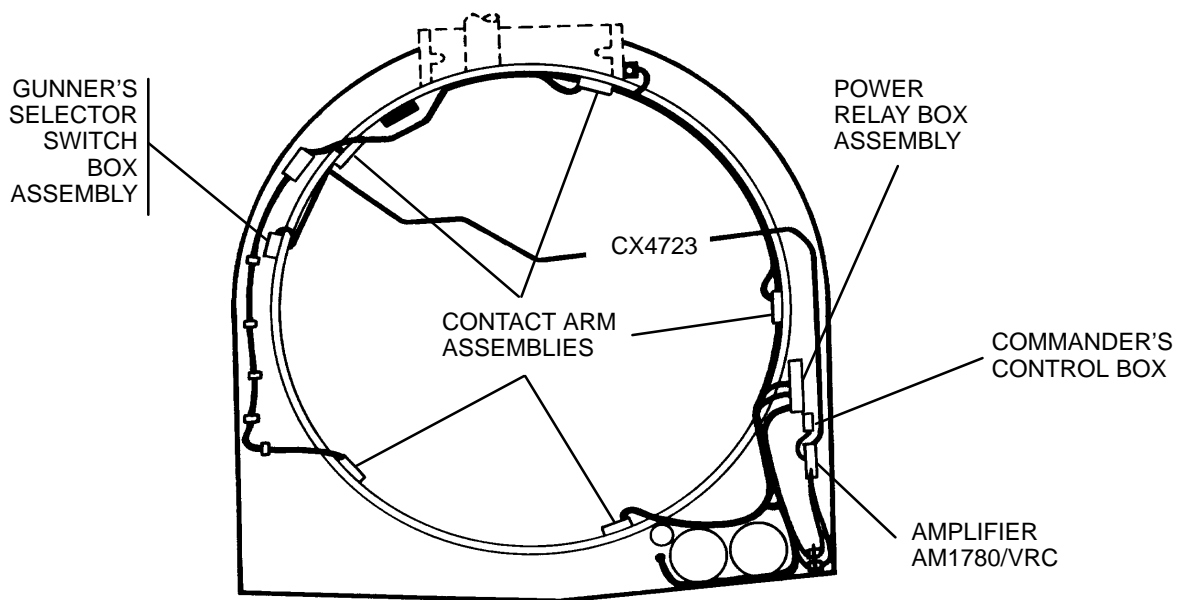
All data on this page has been deleted.

i. INTERCOMMUNICATION SYSTEM

The intercommunication system provides voice communication between crewmembers of the M109 howitzer. The system consists of amplifier AM 1780/VRC and control boxes for the driver, commander, and gunner.

Amplifier AM 1780/VRC provides control of the dc power to the associated crewmember control boxes and to the radio system that may be connected to amplifier AM 1780/VRC. Amplifier AM 1780/VRC also amplifies and controls the audio signals in the intercommunication and radio circuits.

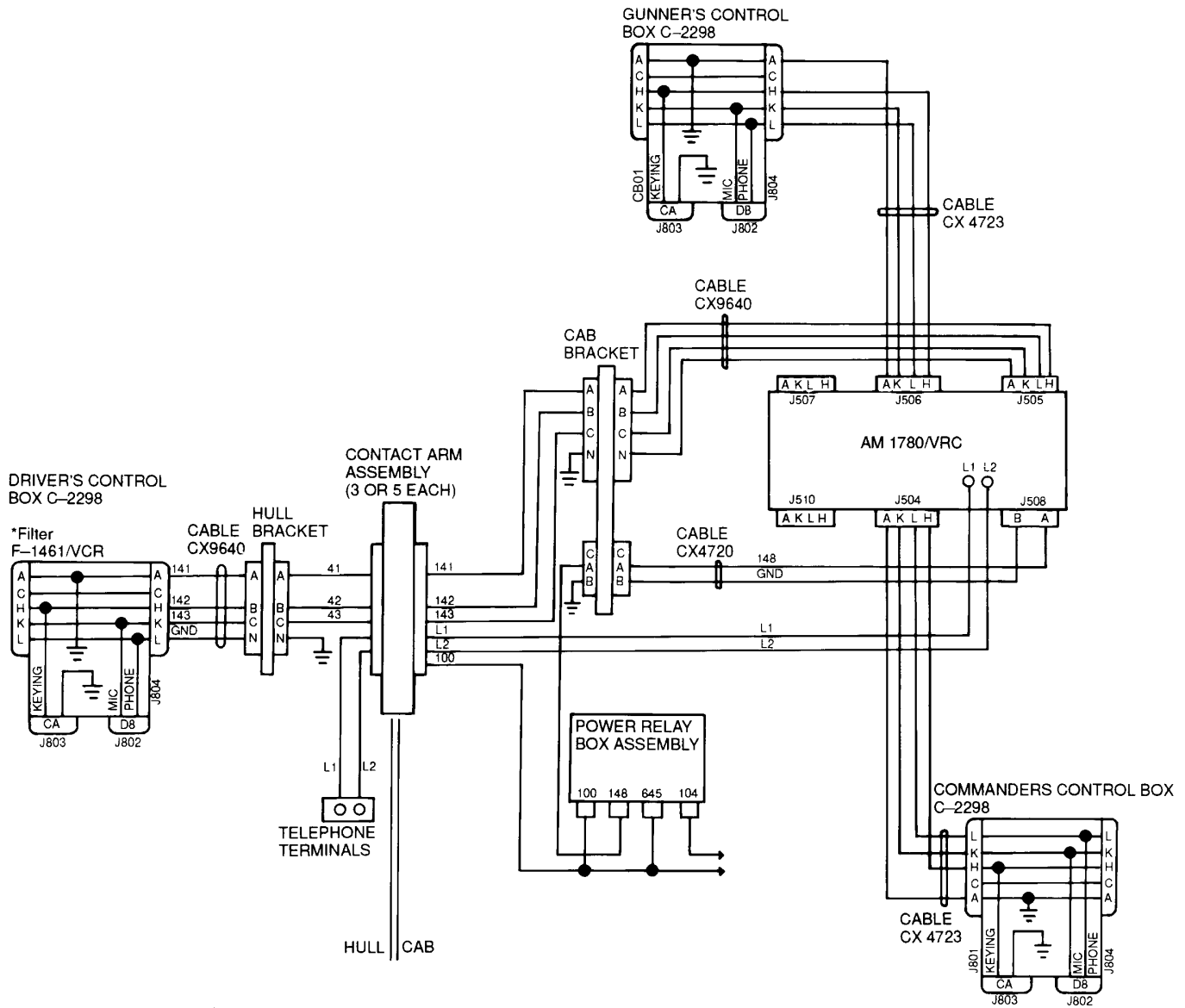
The control box allows crewmembers, by means of the MONITOR switch, to communicate on the intercom circuit with other crewmembers, and on the radio(s) connected to the amplifier AM 1780/VRC. The MONITOR switch is located on the front panel of the control box and the VOLUME control is located on the bottom of the control box. Jacks, J804 and J801, on each side of the control box provide connection to the amplifier AM 1780/VRC. Jacks, J802 and J803, on the bottom of the control box, provide connection to the audio accessories.



PICTORIAL VIEW

### 3-3 TROUBLESHOOTING — CONTINUED

i. INTERCOMMUNICATION SYSTEM — CONTINUED



i. INTERCOMMUNICATION SYSTEM  
— CONTINUED

(1) INTERCOMMUNICATION SYSTEM WILL NOT OPERATE.

**INITIAL SETUP**

Test Equipment

Lead set, test (item 5, Appx H)  
Multimeter (item 6, Appx H)

Tools

Artillery and turret mechanic's tool kit  
(SC 5180-95-CL-A12)

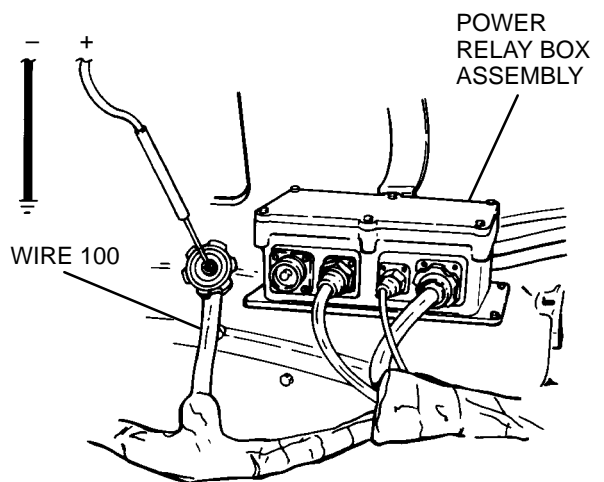
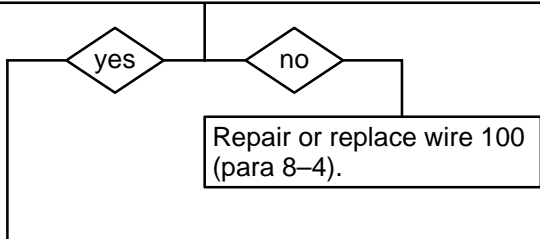
Equipment Condition

Vehicle MASTER switch to OFF (TM 9-2350-311-10)

**A**

1. Disconnect wire 100 from power relay box assembly.
2. Turn MASTER switch to ON.
3. Place red multimeter lead in connector and black lead to ground.
4. Check for voltage.

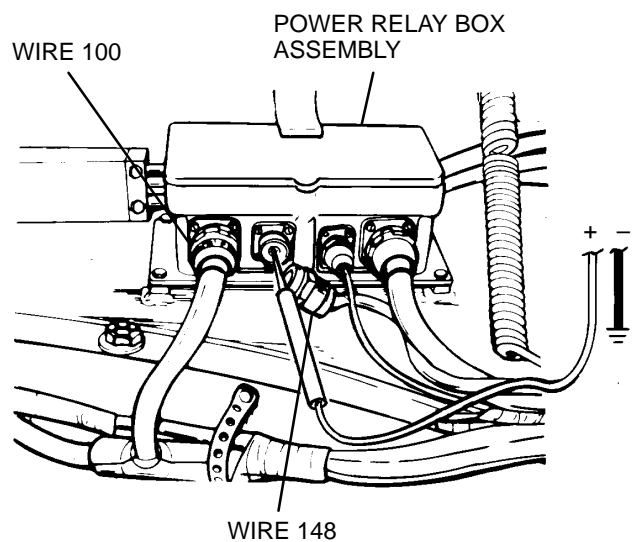
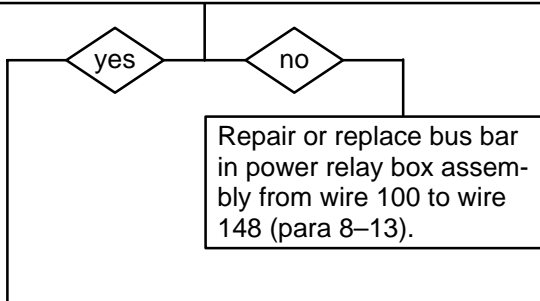
Is battery voltage present?



**B**

1. Turn MASTER switch to OFF.
2. Reconnect wire 100 at power relay box assembly.
3. Disconnect wire 148 at power relay box assembly.
4. Turn MASTER switch to ON.
5. Place red multimeter lead in power relay box assembly terminal and black lead to ground.
6. Check for voltage.

Is battery voltage present?



CONTINUED ON NEXT PAGE

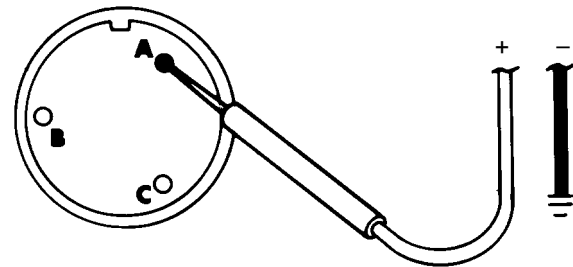
3-3 TROUBLESHOOTING — CONTINUED

i. INTERCOMMUNICATION SYSTEM  
— CONTINUED

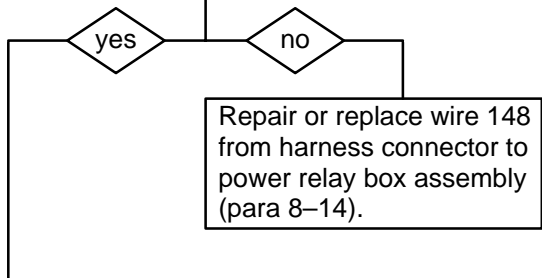
(1) INTERCOMMUNICATION SYSTEM WILL NOT  
OPERATE. — CONTINUED

CONTINUED FROM STEP B

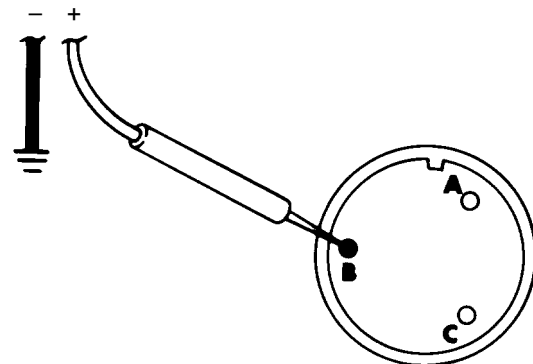
- C**
1. Turn MASTER switch to OFF.
  2. Reconnect wire 148 at power relay box assembly.
  3. Disconnect power relay box to intercom power supply harness connector from cable CX4720.
  4. Turn MASTER switch to ON.
  5. Place red multimeter lead in socket A of harness connector and black lead to ground.
  6. Check for voltage.
- Is battery voltage present?



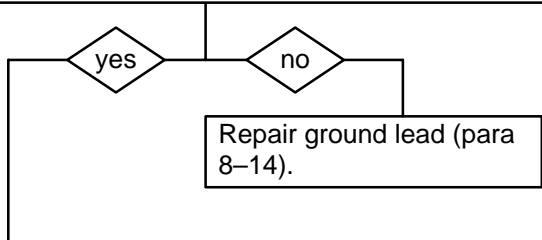
POWER RELAY BOX TO INTERCOM POWER SUPPLY HARNESS CONNECTOR SOCKET A



- D**
1. Turn MASTER switch to OFF.
  2. Place one multimeter lead in socket B of power relay box to intercom power supply harness connector and other lead to ground.
  3. Check for continuity.
- Is continuity present?



POWER RELAY BOX TO INTERCOM POWER SUPPLY HARNESS CONNECTOR SOCKET B



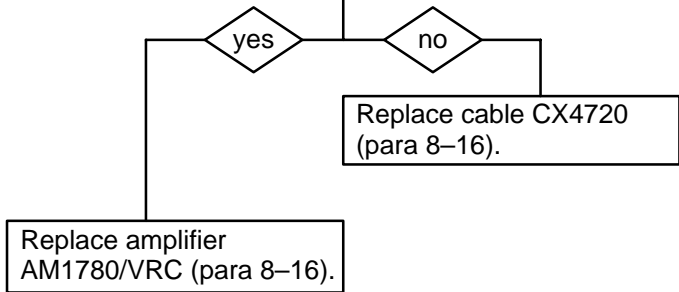
CONTINUED ON NEXT PAGE



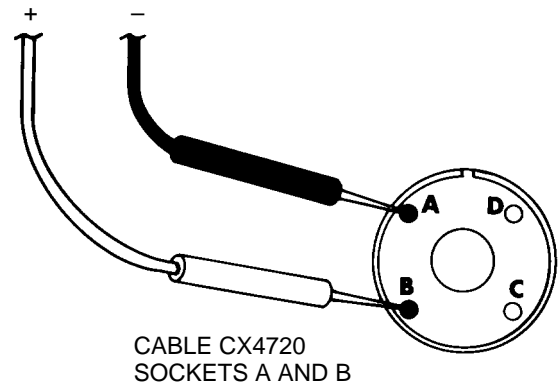
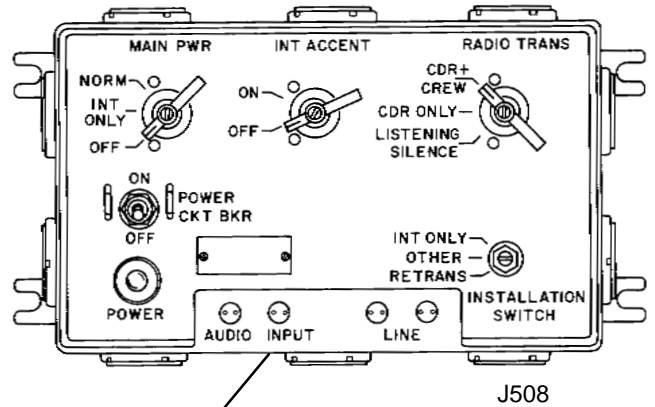
CONTINUED FROM STEP D

- E**
1. Reconnect power relay box to intercom power supply harness to cable CX4720.
  2. Disconnect cable CX4720 from J508 connector at amplifier AM 1780/VRC.
  3. Turn MASTER switch to ON.
  4. Place red multimeter lead in socket B and black lead in socket A.
  5. Check for voltage.

Is battery voltage present?



END OF TASK



**3-3 TROUBLESHOOTING — CONTINUED**

i. INTERCOMMUNICATION SYSTEM  
— CONTINUED

(2) AMPLIFIER AM1780/VRC DOES NOT KEY  
WHEN MIC BUTTON IS PUSHED.

**INITIAL SETUP**

Tools

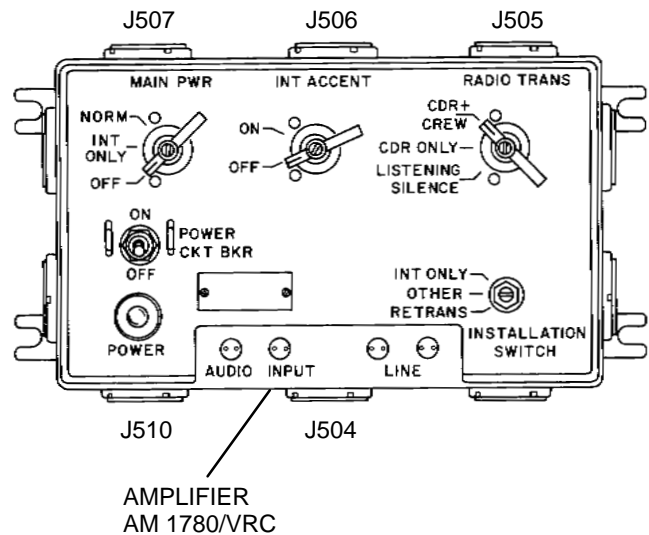
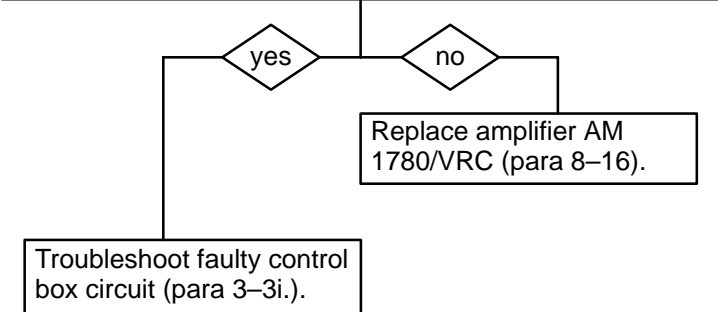
Artillery and turret mechanic's tool kit  
(SC 5180-95-CL-A12)

Equipment Condition

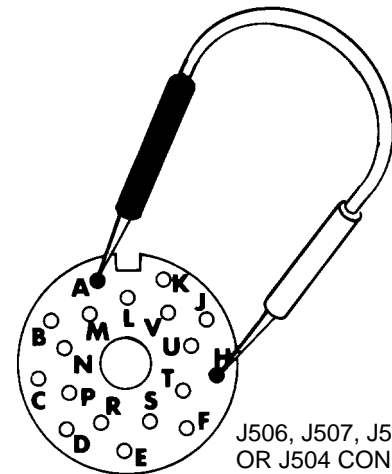
Vehicle MASTER switch to OFF (TM 9-2350-311-10)  
Amplifier AM 1780/VRC POWER switch to OFF  
(TM 9-2350-311-10)

- A**
1. Disconnect cable CX4723 from J506 connector at amplifier AM 1780/VRC.
  2. Turn MASTER and amplifier AM 1780/VRC POWER switches to ON.
  3. Place a jumper wire in socket H and socket A of J506 connector.
  4. Repeat steps 1. through 3. for connectors J507, J505, J510, and J504.

Is a clicking noise heard in amplifier AM 1780/VRC for each test?



AMPLIFIER AM 1780/VRC



J506, J507, J505, J510, OR J504 CONNECTOR

**END OF TASK**

i. INTERCOMMUNICATION SYSTEM  
— CONTINUED

(3) DRIVER CANNOT COMMUNICATE.

**INITIAL SETUP**

Test Equipment

Multimeter (item 6, Appx H)

Tools

Artillery and turret mechanic's tool kit  
(SC 5180-95-CL-A12)

Personnel Required

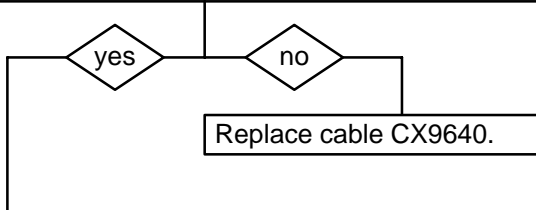
TM 9-2350-311-20-1

Equipment Condition

Amplifier AM 1780/VRC POWER switch to OFF  
(TM 9-2350-311-10)

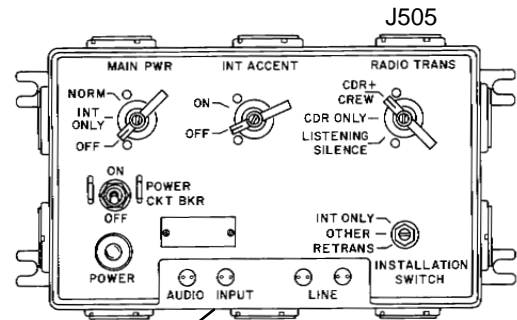
Vehicle MASTER switch to OFF (TM 9-2350-311-10)

- A**
1. Disconnect cable CX9640 from J505 connector at amplifier AM 1780/VRC.
  2. Disconnect other end of cable CX9640 from power system wiring harness connector.
  3. Place one multimeter lead in position 1 and other lead in position 2 for individual continuity checks.
- | POSITION 1 | POSITION 2 |
|------------|------------|
| B          | L          |
| C          | K          |
| A          | H          |
4. Check for continuity.
- Is continuity present?

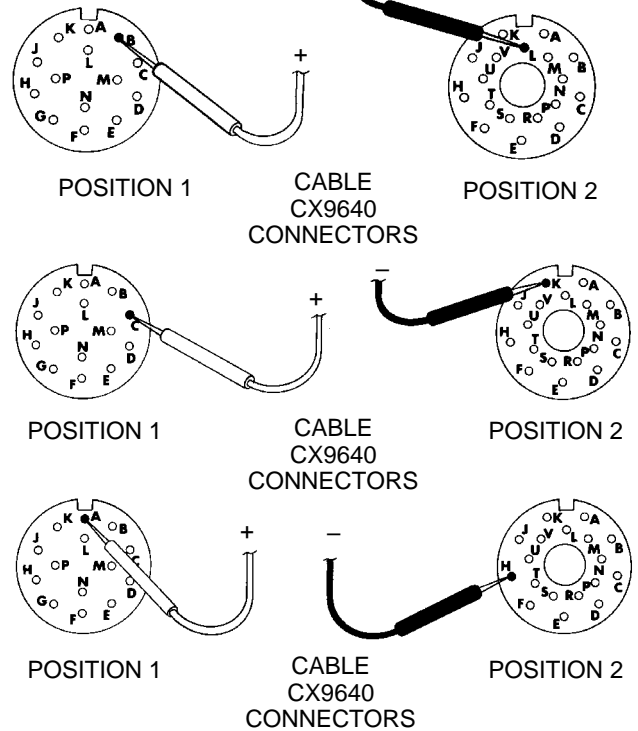


**NOTE**  
Steps B through L must be repeated for each contact arm assembly.

CONTINUED ON NEXT PAGE



AMPLIFIER  
AM 1780/VRC



3-3 TROUBLESHOOTING — CONTINUED

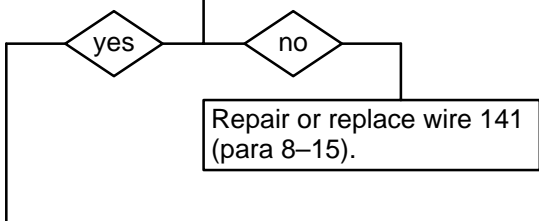
i. INTERCOMMUNICATION SYSTEM  
— CONTINUED

(3) DRIVER CANNOT COMMUNICATE.  
— CONTINUED

CONTINUED FROM STEP A

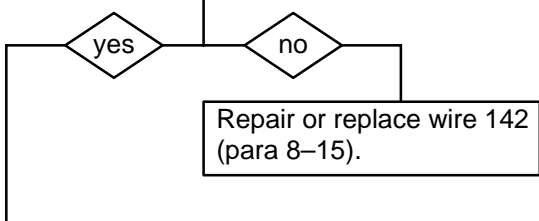
- B**
1. Reconnect cable CX9640 at J505 connector of amplifier AM 1780/VRC.
  2. Disconnect wire 141 from contact arm assembly quick-disconnect.
  3. Place one multimeter lead in wire 141 quick-disconnect and other lead in socket A of power system wiring harness connector.
  4. Check for continuity.

Is continuity present?

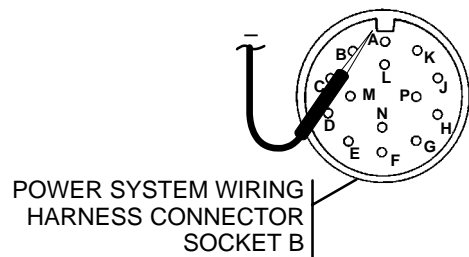
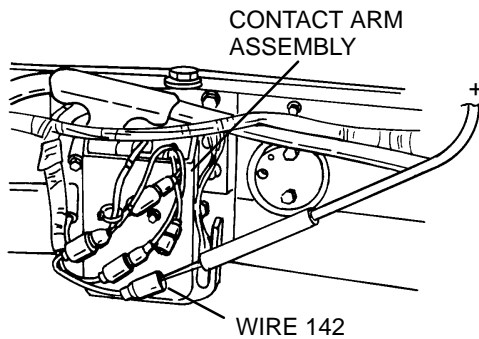
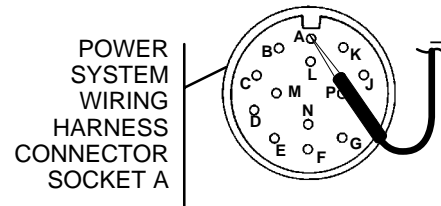
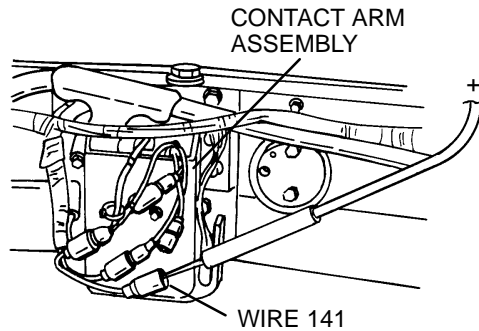


- C**
1. Reconnect wire 141 at contact arm assembly quick-disconnect.
  2. Disconnect wire 142 from contact arm assembly quick-disconnect.
  3. Place one multimeter lead in wire 142 quick-disconnect and other lead in socket B of power system wiring harness connector.
  4. Check for continuity.

Is continuity present?



CONTINUED ON NEXT PAGE

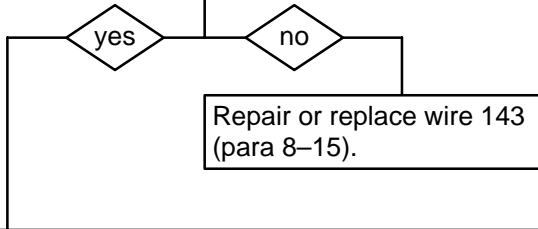


CONTINUED FROM STEP C

**D**

1. Reconnect wire 142 at contact arm assembly quick-disconnect.
2. Disconnect wire 143 from contact arm assembly quick-disconnect.
3. Place one multimeter lead in wire 143 quick-disconnect and other lead in socket C of power system wiring harness connector.
4. Check for continuity.

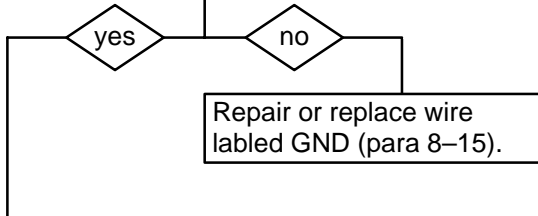
Is continuity present?



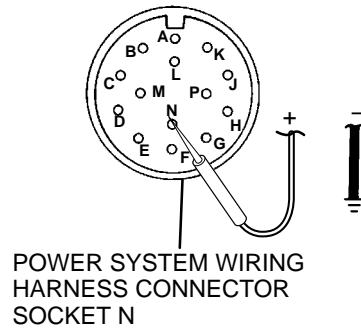
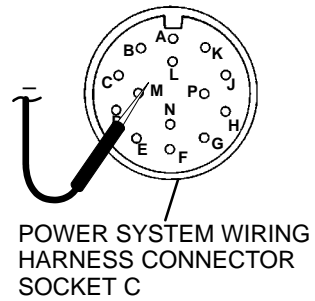
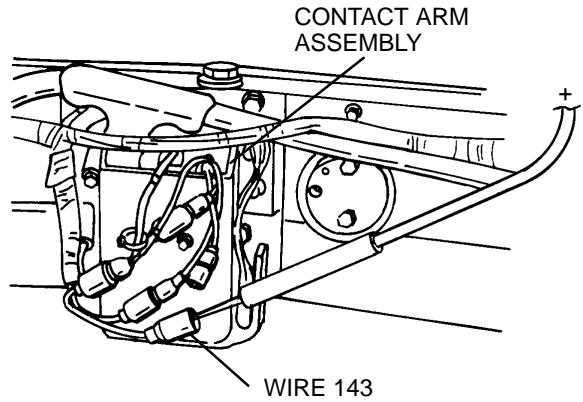
**E**

1. Reconnect wire 143 at contact arm assembly quick-disconnect.
2. Place one multimeter lead in socket N of power system wiring harness connector and other lead to ground.
3. Check for continuity.

Is continuity present?



CONTINUED ON NEXT PAGE



**3-3 TROUBLESHOOTING — CONTINUED**

i. INTERCOMMUNICATION SYSTEM  
— CONTINUED

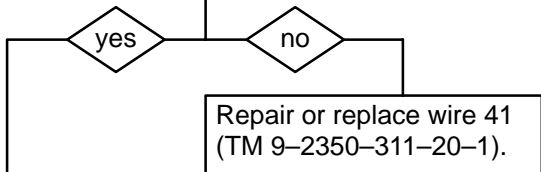
(3) DRIVER CANNOT COMMUNICATE.  
— CONTINUED

CONTINUED FROM STEP E

**F**

1. Reconnect cable CX9640 connector to power system wiring harness connector.
2. Disconnect cable CX9640 from telephone/intercom wiring harness connector in driver's compartment of hull.
3. Place one multimeter lead on wire 41 terminal and other lead in socket A of telephone/intercom wiring harness connector.
4. Check for continuity.

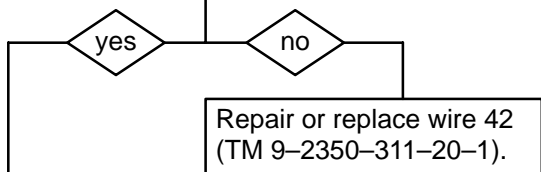
Is continuity present?



**G**

1. Place one multimeter lead on wire 42 terminal and other lead in socket B of telephone/intercom wiring harness connector.
2. Check for continuity.

Is continuity present?

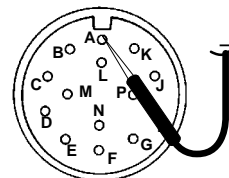
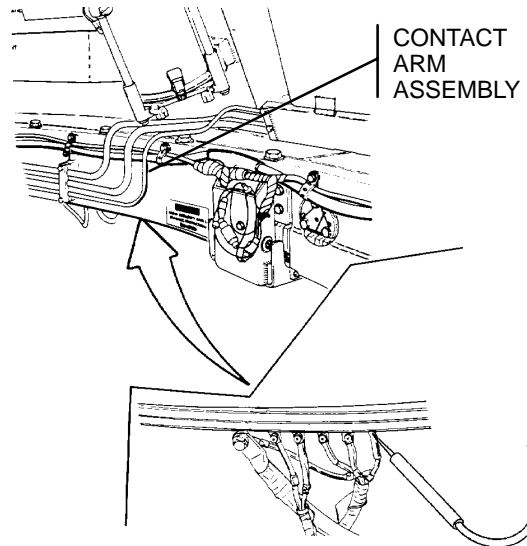


**H**

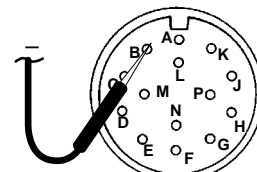
1. Place one multimeter lead on wire 43 terminal and other lead in socket C of telephone/intercom wiring harness connector.
2. Check for continuity.

Is continuity present?

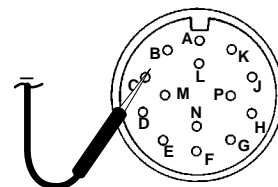
CONTINUED ON NEXT PAGE



TELEPHONE/INTERCOM WIRING HARNESS CONNECTOR SOCKET A

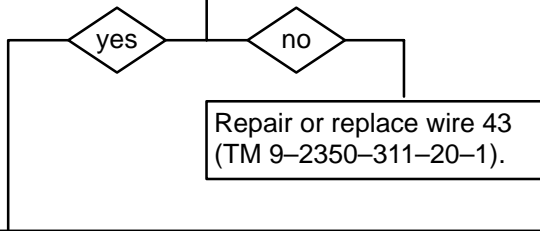


TELEPHONE/INTERCOM WIRING HARNESS CONNECTOR SOCKET B



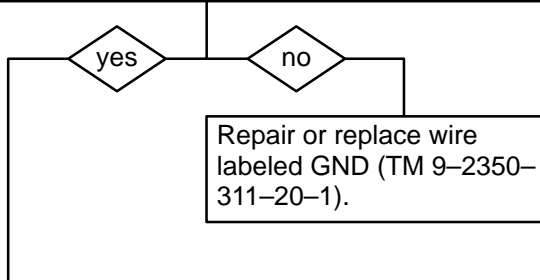
TELEPHONE/INTERCOM WIRING HARNESS CONNECTOR SOCKET C

CONTINUED FROM STEP H



**I** 1. Place one multimeter lead in socket N of telephone intercom wiring harness connector and other lead to ground.  
2. Check for continuity.

Is continuity present?

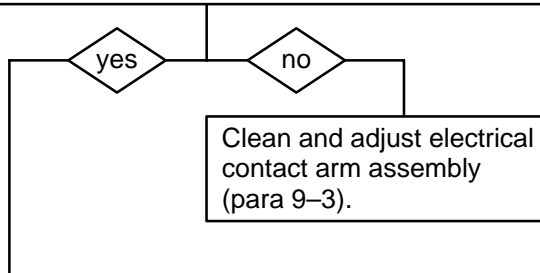


**J** 1. Disconnect position 1 wires at contact arm assembly quick-disconnects to place one multimeter lead in position 1 and other lead to position 2 terminals for individual continuity checks.

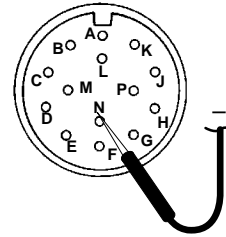
<u>POSITION 1</u>	<u>POSITION 2</u>
Wire 141	Wire 41
Wire 142	Wire 42
Wire 143	Wire 43

2. Check for continuity.

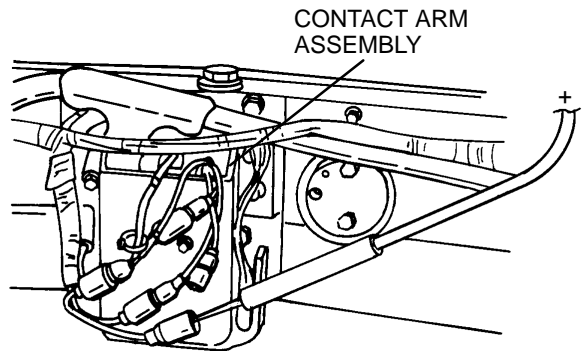
Is continuity present?



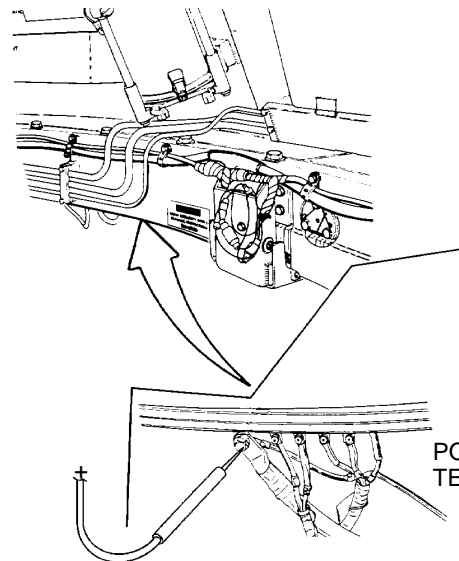
CONTINUED ON NEXT PAGE



TELEPHONE/INTERCOM WIRING HARNESS CONNECTOR SOCKET N



POSITION 1 POWER SYSTEM WIRING HARNESS QUICK-DISCONNECTS



POSITION 2 TERMINALS

3-3 TROUBLESHOOTING — CONTINUED

i. INTERCOMMUNICATION SYSTEM  
— CONTINUED

(3) DRIVER CANNOT COMMUNICATE.  
— CONTINUED

CONTINUED FROM STEP J

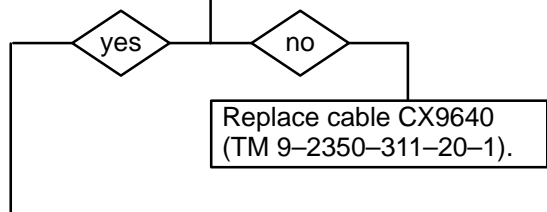
**K**

1. Reconnect wires 141, 142, and 143 at contact arm assembly quick-disconnects.
2. Disconnect cable CX9640 at driver's control box.
3. Place one multimeter lead in position 1 and other lead in position 2 for individual continuity checks.

POSITION 1	POSITION 2
A	H
C	K
B	L

4. Check for continuity.

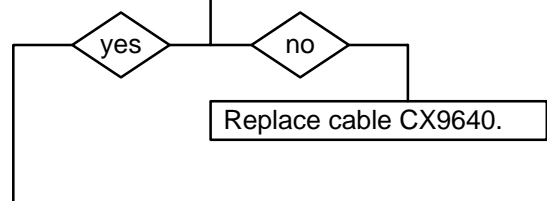
Is continuity present?



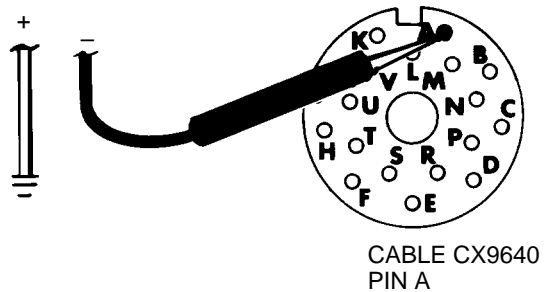
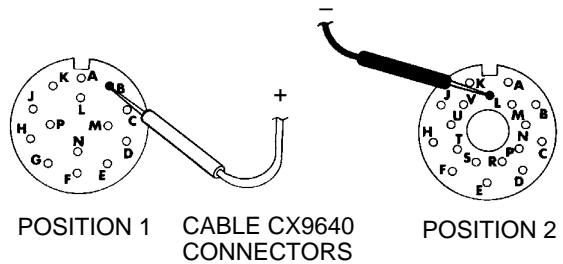
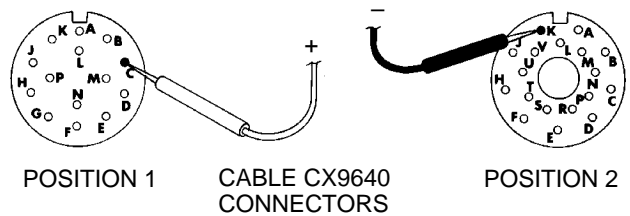
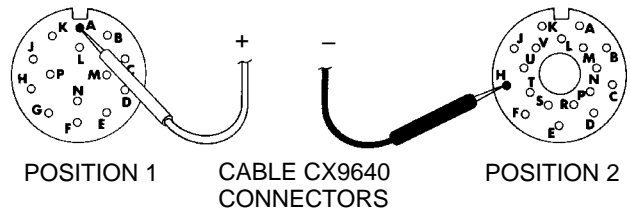
**L**

1. Reconnect cable CX9640 connector to telephone/intercom wiring harness connector.
2. Place one multimeter lead in pin A of cable CX9640 and other lead to ground.
3. Check for continuity.

Is continuity present?



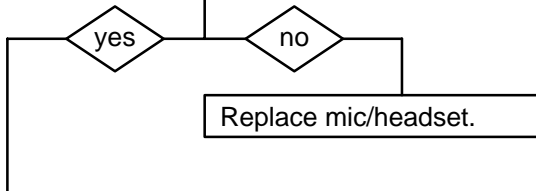
CONTINUED ON NEXT PAGE





CONTINUED FROM STEP L

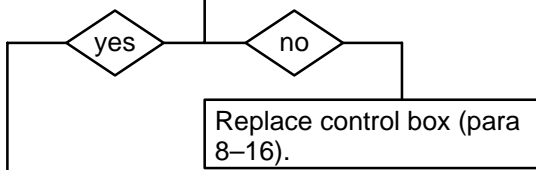
- M**
1. Reconnect cable CX9640 at driver's control box.
  2. Disconnect driver's mic/headset from control box.
  3. Connect mic/headset to a control box that is operating properly.
  4. Turn MASTER and amplifier AM 1780/VRC POWER switches to ON.
  5. Operate mic/headset.
- Does mic/headset operate properly?



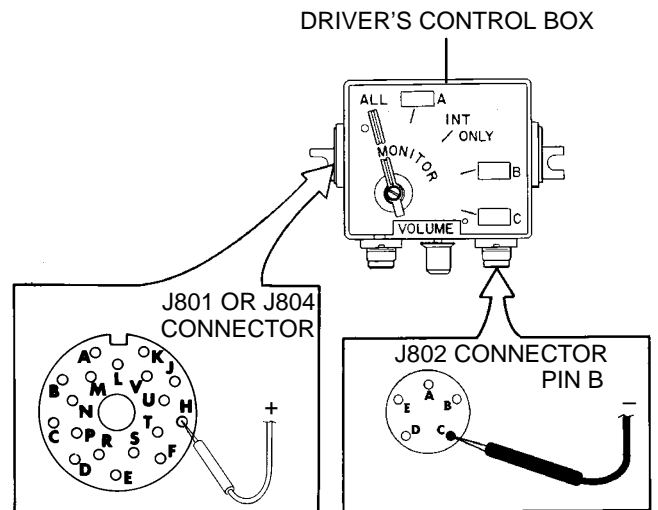
**NOTE**  
The following checks must be made on J801 and J804 connectors.

- N**
1. Turn MASTER and amplifier AM 1780/VRC POWER switches to OFF.
  2. Place control box MONITOR switch to ALL and VOLUME to maximum.
  3. Disconnect cable CX4723 from J801 or J804 connector.
  4. Place one multimeter lead in socket L of J801 or J804 connector and other lead to pin B of J802 connector.
  5. Check for continuity.

Is continuity present?



CONTINUED ON NEXT PAGE



3-3 TROUBLESHOOTING — CONTINUED

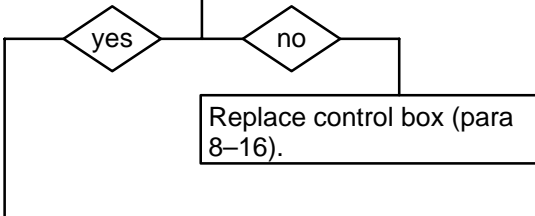
i. INTERCOMMUNICATION SYSTEM  
— CONTINUED

(3) DRIVER CANNOT COMMUNICATE.  
— CONTINUED

CONTINUED FROM STEP N

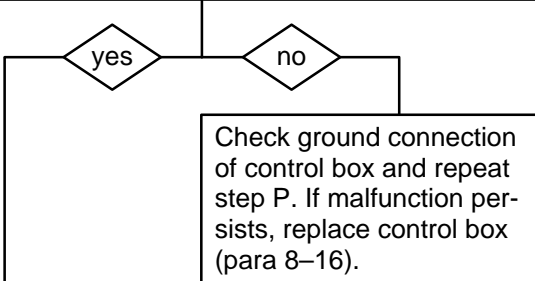
**O** 1. Place one multimeter lead in socket H of J801 or J804 connector and other lead to pin C of J803 connector.  
2. Check for continuity.

Is continuity present?

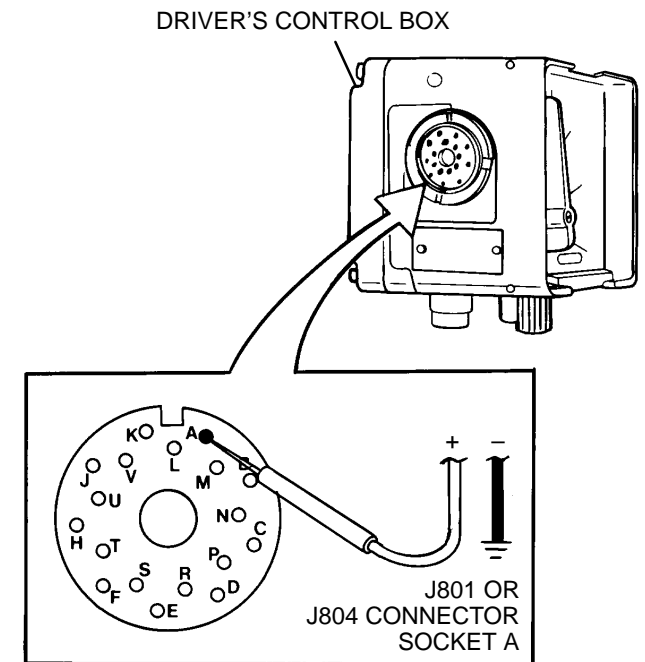
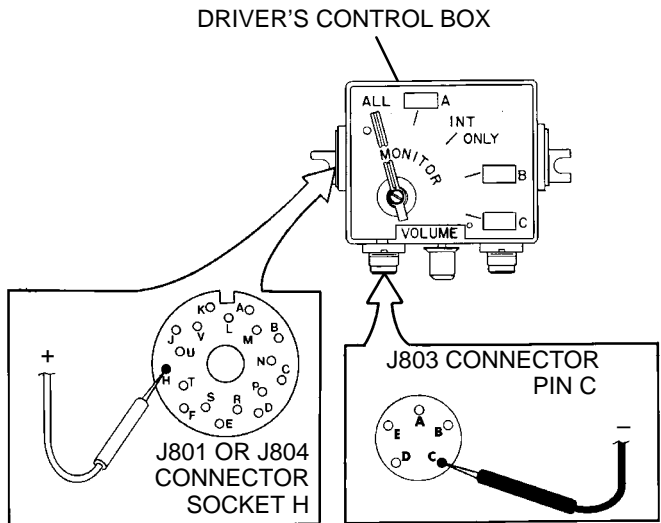


**P** 1. Place one multimeter lead in socket A of J801 or J804 connector and other lead to ground.  
2. Check for continuity.

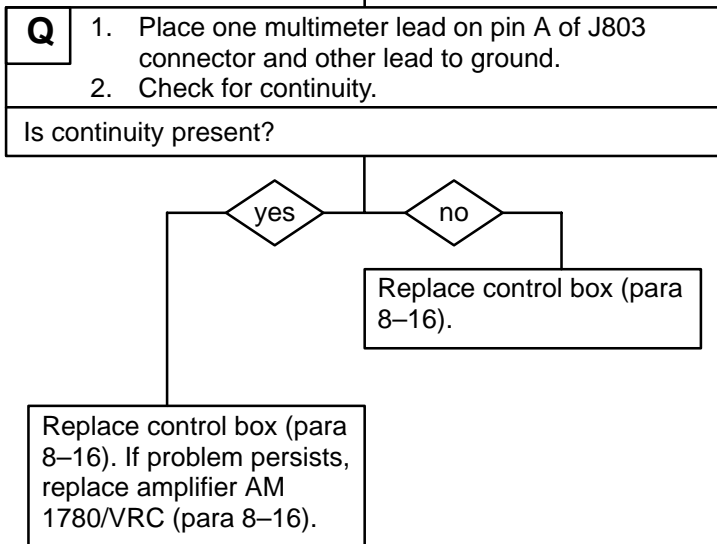
Is continuity present?



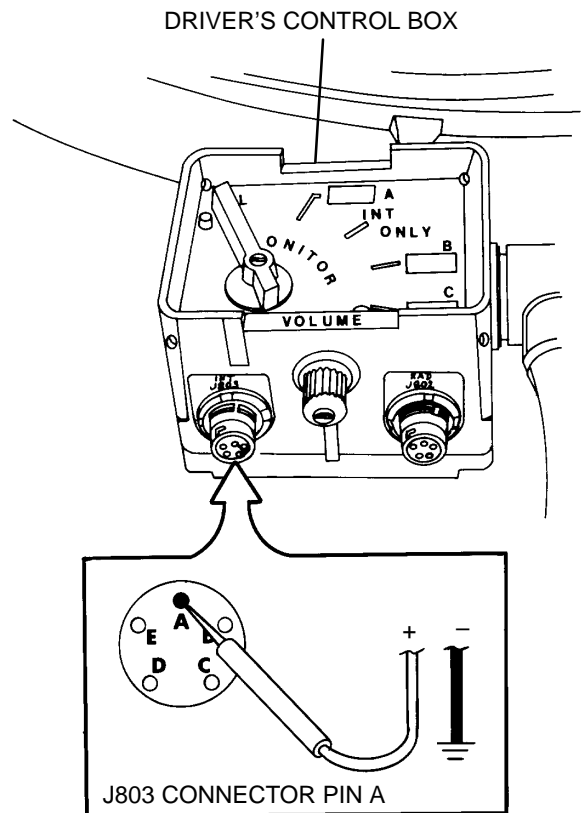
CONTINUED ON NEXT PAGE



CONTINUED FROM STEP P



END OF TASK



i. INTERCOMMUNICATION SYSTEM  
— CONTINUED

(4) OPERATOR CANNOT COMMUNICATE AT GUNNER'S OR COMMANDER'S CONTROL BOX.

**INITIAL SETUP**

Test Equipment

Multimeter (item 6, Appx H)

Tools

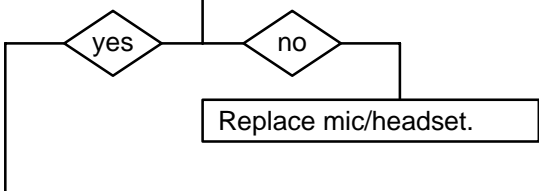
Artillery and turret mechanic's tool kit  
(SC 5180-95-CL-A12)

Equipment Condition

Amplifier AM 1780/VRC POWER switch to OFF  
(TM 9-2350-311-10)

Vehicle MASTER switch to OFF (TM 9-2350-311-10)

- A**
1. Disconnect operator's mic/headset from control box.
  2. Connect mic/headset to a control box that is operating correctly.
  3. Turn MASTER and amplifier AM 1780/VRC POWER switches to ON.
  4. Operate mic/headset.
- Does mic/headset operate properly?



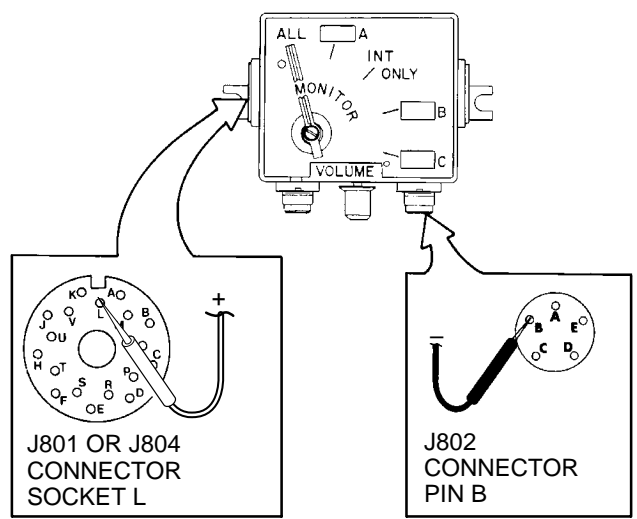
**NOTE**

The following checks must be made on connectors J801 and J804.

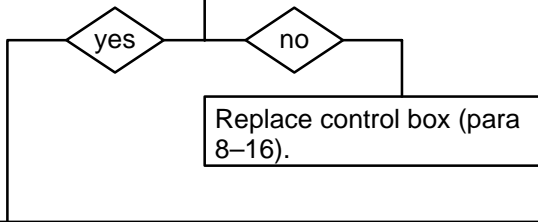
- B**
1. Turn MASTER and amplifier AM1780/VRC POWER switches to OFF.
  2. Place control box MONITOR switch to ALL and VOLUME to maximum.
  3. Disconnect cable CX4723 from J801 or J804 connector.
  4. Place one multimeter lead in socket L of J801 or J804 connector and other lead to pin B of J802 connector.
  5. Check for continuity.

Is continuity present?

CONTINUED ON NEXT PAGE

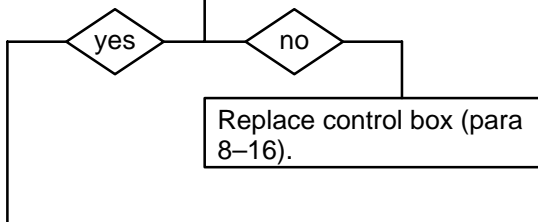


CONTINUED FROM STEP B



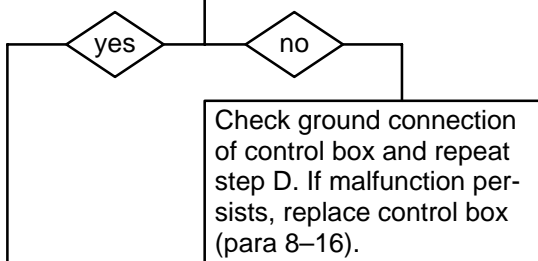
- C**
1. Place one multimeter lead in socket H of J801 or J804 connector and other lead to pin C of J803 connector.
  2. Check for continuity.

Is continuity present?



- D**
1. Place one multimeter lead in socket A of J801 or J804 connector and other lead to ground.
  2. Check for continuity.

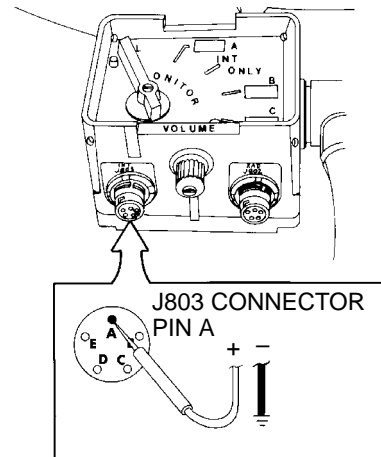
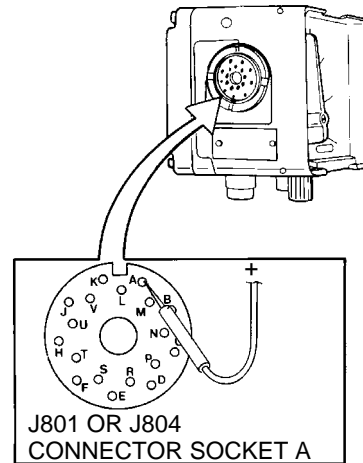
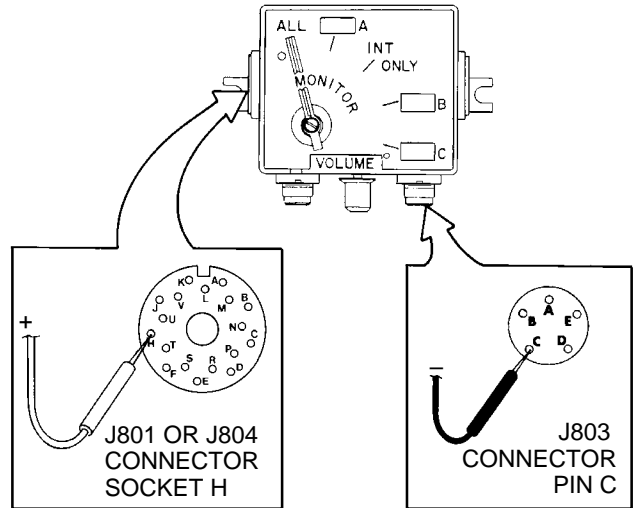
Is continuity present?



- E**
1. Place one multimeter lead on pin A of J803 connector and other lead to ground.
  2. Check for continuity.

Is continuity present?

CONTINUED ON NEXT PAGE

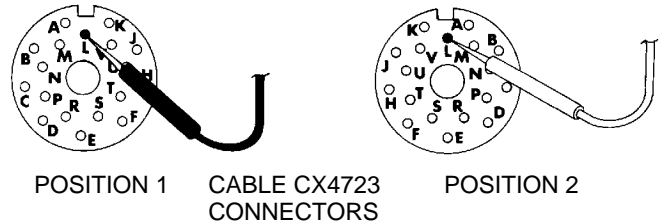
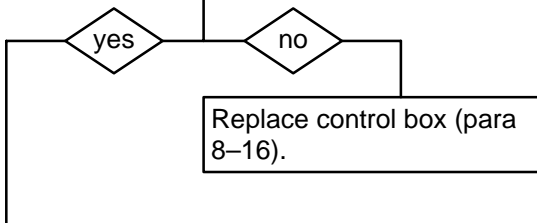


3-3 TROUBLESHOOTING — CONTINUED

i. INTERCOMMUNICATION SYSTEM  
— CONTINUED

(4) OPERATOR CANNOT COMMUNICATE AT  
GUNNER'S OR COMMANDER'S CONTROL  
BOX. — CONTINUED

CONTINUED FROM STEP E



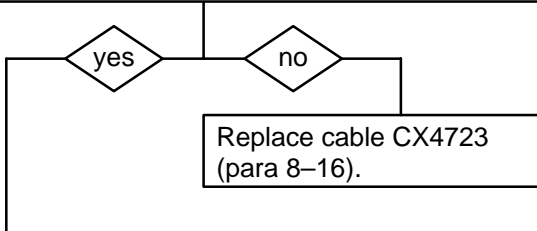
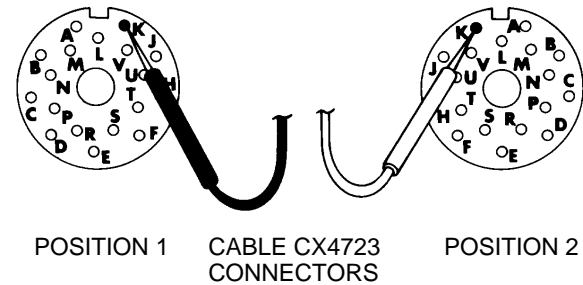
**F**

1. Disconnect cable CX4723 at amplifier AM1780/VRC.
2. Place one multimeter lead in position 1 and other lead in position 2 for individual continuity checks.

POSITION 1	POSITION 2
L	L
K	K
H	H

3. Check for continuity.

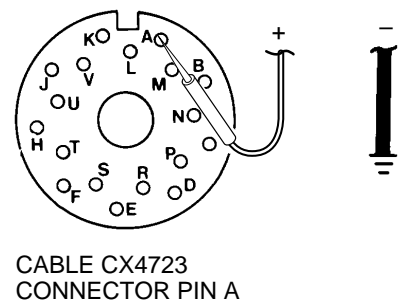
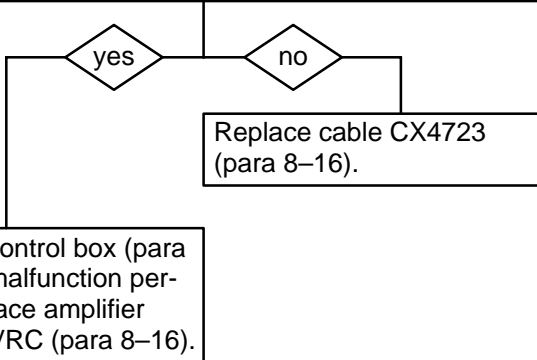
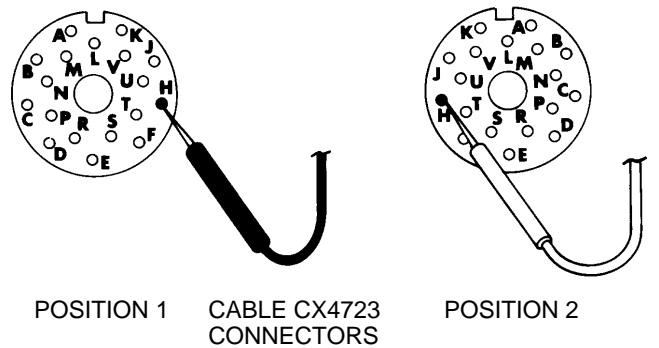
Is continuity present?



**G**

1. Reconnect cable CX4723 at amplifier AM1780/VRC.
2. Place one multimeter lead on cable CX4723 pin A and other lead to ground.
3. Check for continuity.

Is continuity present?



END OF TASK

i. INTERCOMMUNICATION SYSTEM  
— CONTINUED

(5) TELEPHONE OPERATOR CANNOT COMMUNICATE.

**INITIAL SETUP**

Test Equipment

Multimeter (item 6, Appx H)

Tools

Artillery and turret mechanic's tool kit  
(SC 5180-95-CL-A12)

Personnel Required

2

Personnel Required

TM 9-2350-311-20-1

Equipment Condition

Amplifier AM 1780/VRC POWER switch to OFF  
(TM 9-2350-311-10)

Vehicle MASTER switch to OFF (TM 9-2350-311-10)

**NOTE**

Two personnel are required to perform the following steps. Steps A through D must be repeated for each contact arm assembly.

**A**

1. Disconnect wire L2 at contact arm assembly quick-disconnect.
2. Place one multimeter lead in wire L2 and other lead on terminal L2 of telephone connector on back of vehicle.
3. Check for continuity.

Is continuity present?

yes

no

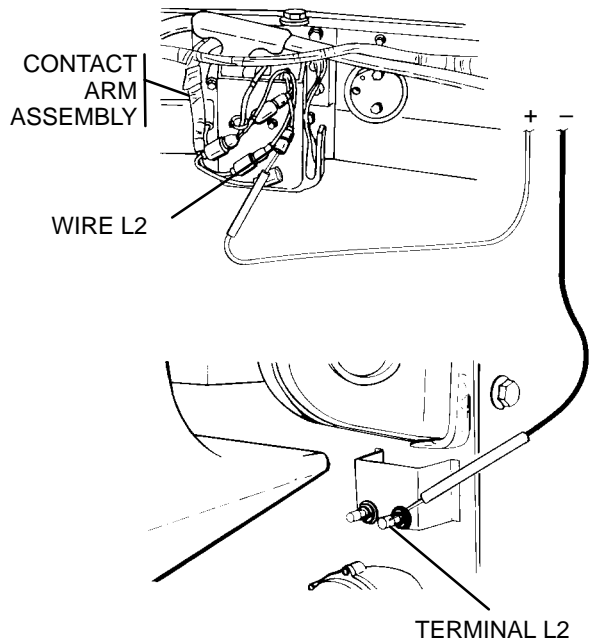
Go to step C.

**B**

1. Clean and adjust electrical contact arm assembly (para 9-3).
2. Place one multimeter lead in wire L2 and other lead on terminal L2 of telephone connector on back of vehicle.
3. Check for continuity.

Is continuity present?

CONTINUED ON NEXT PAGE

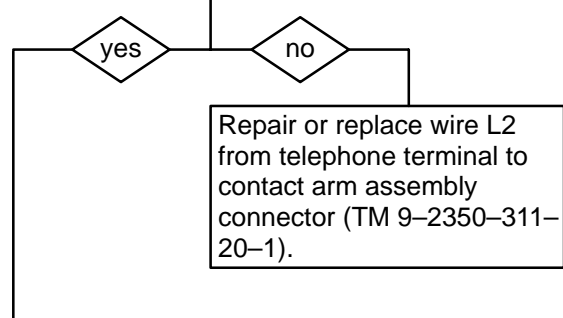


3-3 TROUBLESHOOTING — CONTINUED

i. INTERCOMMUNICATION SYSTEM  
— CONTINUED

(5) TELEPHONE OPERATOR CANNOT COMMUNICATE. — CONTINUED

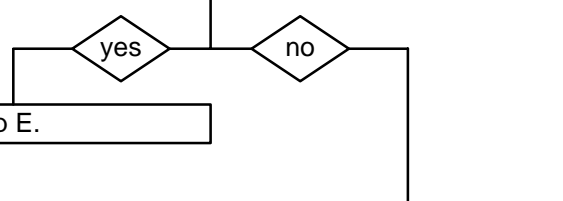
CONTINUED FROM STEP A OR B



**C**

1. Connect wire L2 at contact arm assembly quick-disconnect.
2. Disconnect wire L1 at contact arm assembly quick-disconnect.
3. Place one multimeter lead in wire L1 and other lead on terminal L1 of telephone connector on back of vehicle.
4. Check for continuity.

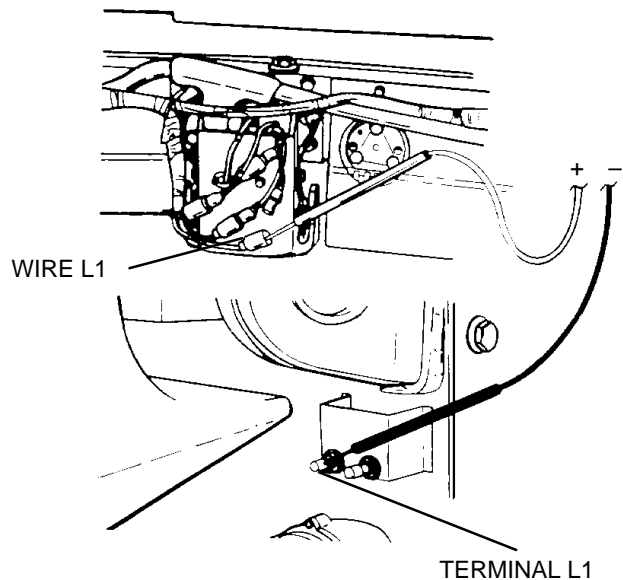
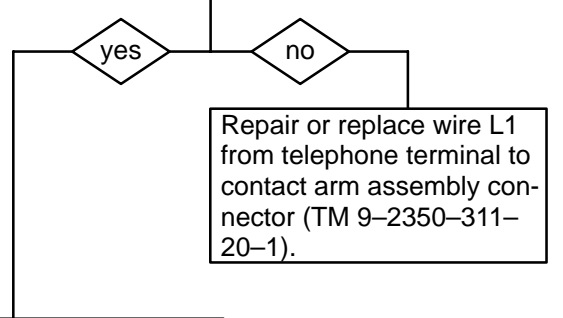
Is continuity present?



**D**

1. Clean and adjust electrical contact holder and brushes (para 9-3).
2. Place one multimeter lead in wire L1 and other lead on terminal L1 of telephone connector on back of vehicle.
3. Check for continuity.

Is continuity present?

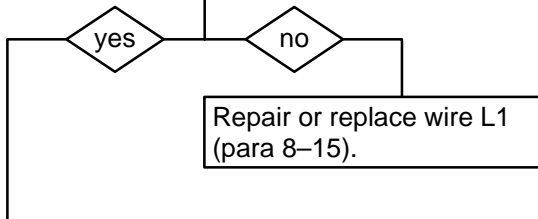


CONTINUED ON NEXT PAGE

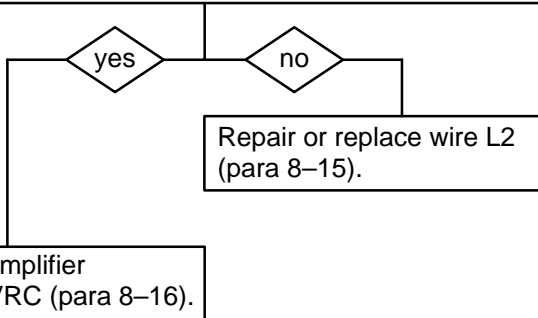


CONTINUED FROM STEP C OR D

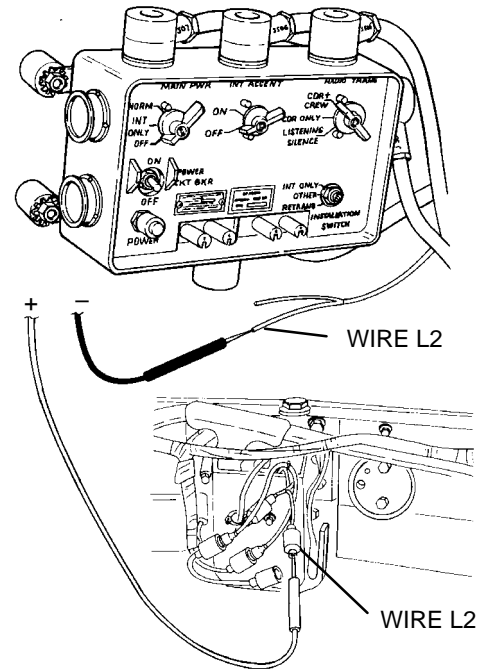
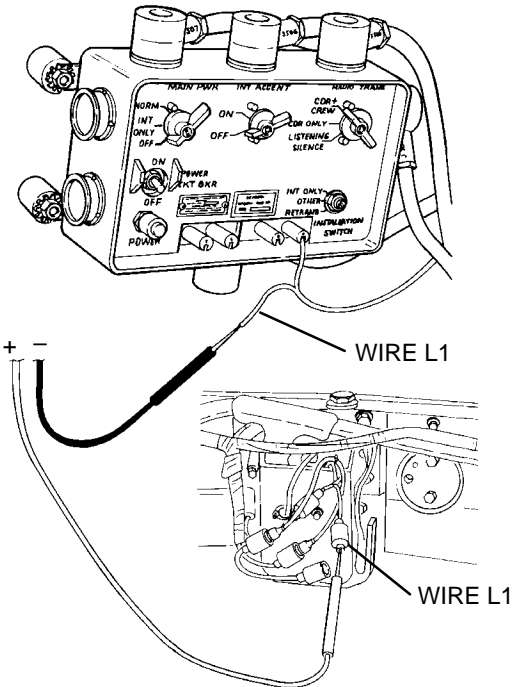
- E**
1. Disconnect wire L1 from amplifier AM 1780/VRC.
  2. Place one multimeter lead in wire L1 connector other lead on opposite side of wire L1.
  3. Check for continuity.
- Is continuity present?



- F**
1. Reconnect wire L1 at contact arm assembly quick-disconnect.
  2. Disconnect wire L2 at contact arm assembly quick-disconnect.
  3. Place one multimeter lead in wire L2 connector and other lead on opposite side of wire L2.
  4. Check for continuity.
- Is continuity present?



END OF TASK

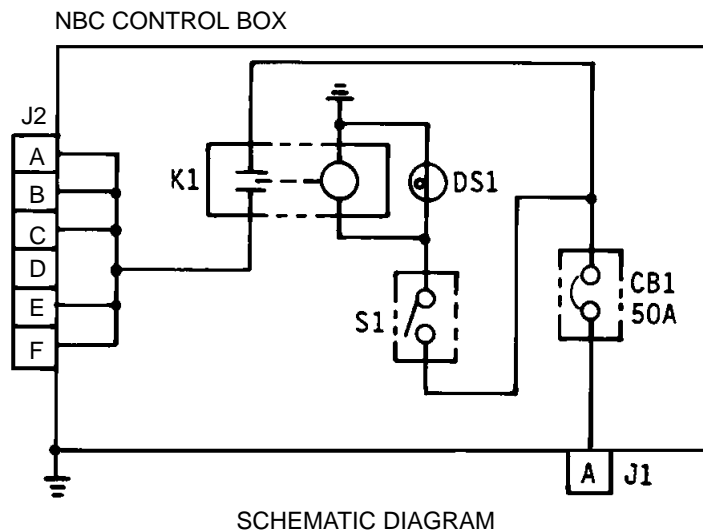
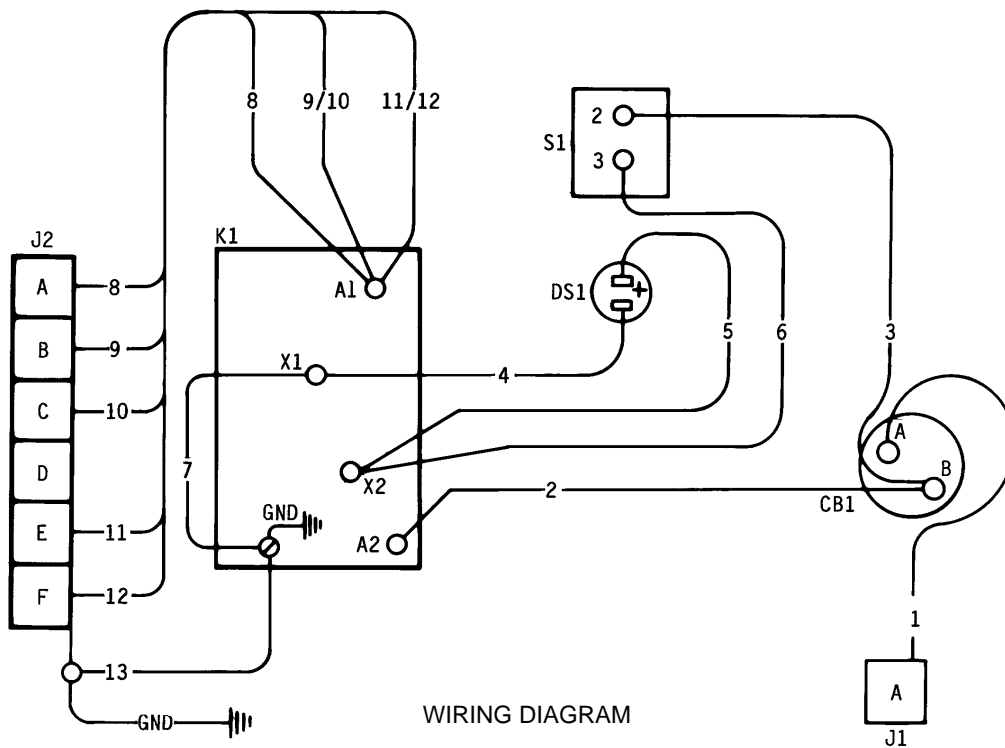


3-3 TROUBLESHOOTING — CONTINUED

j. NBC SYSTEM CIRCUIT

The NBC system consists of an NBC control box assembly, M2A2 air purifier, and gunner's, cannoneer no. 1's, section chief's, and assistant gunner's M3 electric air heater.

All power to the NBC components is controlled through the NBC power switch which is accompanied by an indicator light.



j. NBC SYSTEM CIRCUIT — CONTINUED

(1) NBC CONTROL BOX ASSEMBLY INDICATOR LIGHT DOES NOT ILLUMINATE, BUT NBC SYSTEM OPERATES.

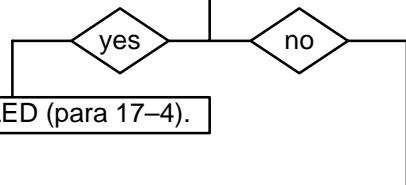
**INITIAL SETUP**

Applicable Configuration  
M109A4/M109A5 howitzers  
Test Equipment  
Multimeter (item 6, Appx H)

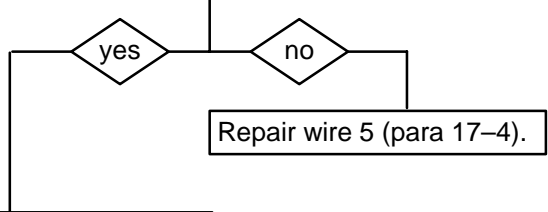
Tools  
Artillery and turret mechanic's tool kit  
(SC 5180-95-CL-A12)

Equipment Condition  
Vehicle MASTER switch to OFF (TM 9-2350-311-10)  
CAB NBC POWER switch to OFF (TM 9-2350-311-10)

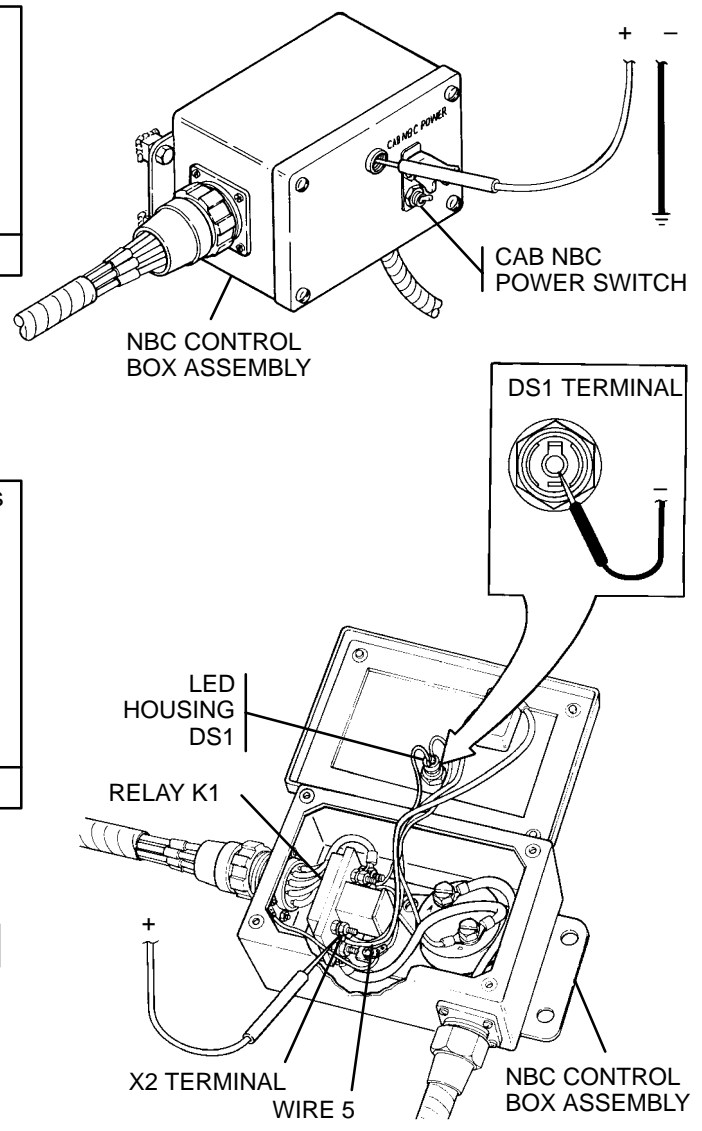
- A**
1. Remove lens and LED from NBC control box assembly (para 17-4).
  2. Turn MASTER and CAB NBC POWER switches to ON.
  3. Place red multimeter lead in LED housing and black lead to ground.
  4. Check for voltage.
- Is battery voltage present?



- B**
1. Turn MASTER and CAB NBC POWER switches to OFF.
  2. Install lens and LED in NBC control box assembly (para 17-4).
  3. Remove cover from NBC control box assembly.
  4. Place one multimeter lead on X2 terminal of electromagnetic relay K1 and other lead to positive terminal on LED housing DS1.
  5. Check for continuity.
- Is continuity present?



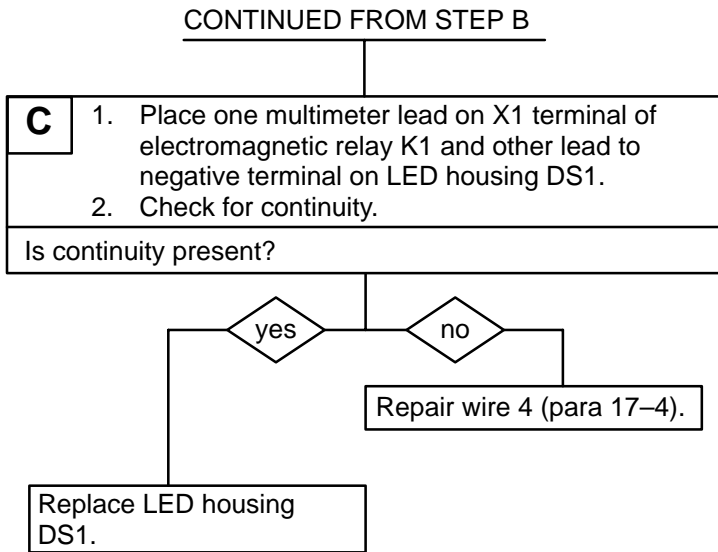
CONTINUED ON NEXT PAGE



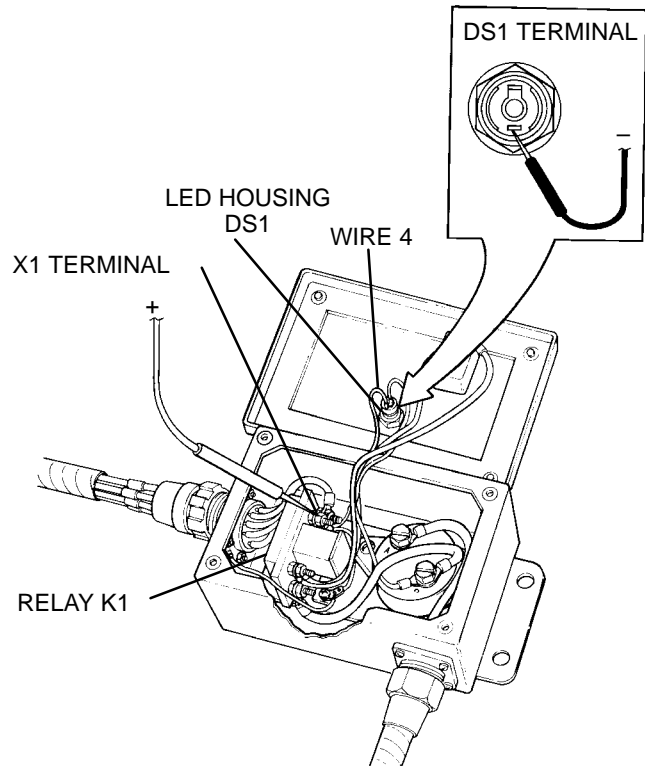
**3-3 TROUBLESHOOTING — CONTINUED**

j. NBC SYSTEM CIRCUIT — CONTINUED

(1) NBC CONTROL BOX ASSEMBLY INDICATOR LIGHT DOES NOT ILLUMINATE, BUT NBC SYSTEM OPERATES – CONTINUED.



**END OF TASK**



j. NBC SYSTEM CIRCUIT — CONTINUED

(2) NBC SYSTEM DOES NOT OPERATE.

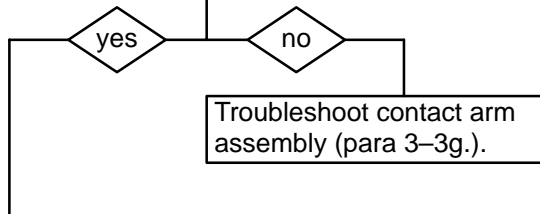
**INITIAL SETUP**

Applicable Configuration  
M109A4/M109A5 howitzers  
Test Equipment  
Multimeter (item 6, Appx H)

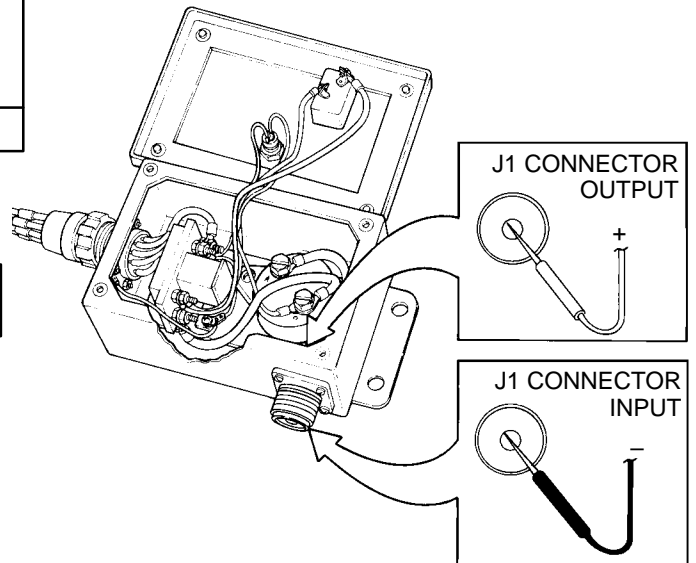
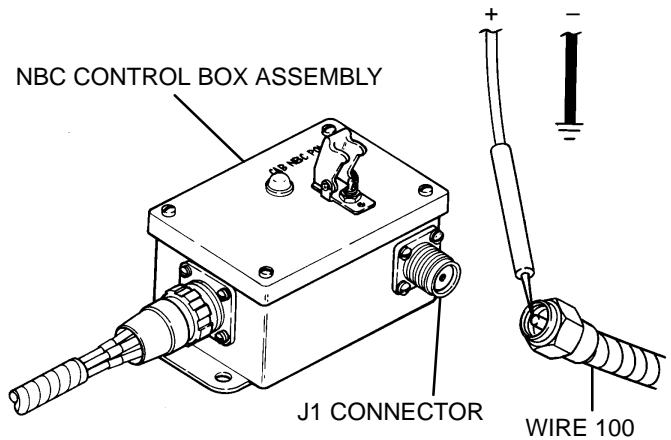
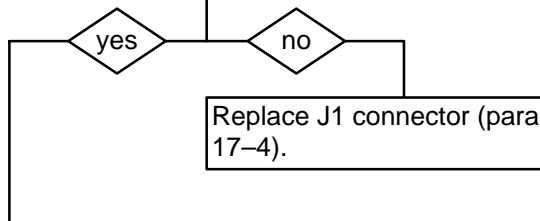
Tools  
Artillery and turret mechanic's tool kit  
(SC 5180-95-CL-A12)

Equipment Condition  
Vehicle MASTER switch to OFF (TM 9-2350-311-10)  
CAB NBC POWER switch to OFF (TM 9-2350-311-10)

- A**
1. Disconnect wire 100 from J1 connector on bottom of NBC control box assembly.
  2. Turn MASTER switch to ON.
  3. Place red multimeter lead in wire 100 and black lead to ground.
  4. Check for voltage.
- Is battery voltage present?



- B**
1. Turn MASTER switch to OFF.
  2. Place one multimeter lead on output side and other lead to input side of J1 connector on NBC control box assembly.
  3. Check for continuity.
- Is continuity present?



CONTINUED ON NEXT PAGE

3-3 TROUBLESHOOTING — CONTINUED

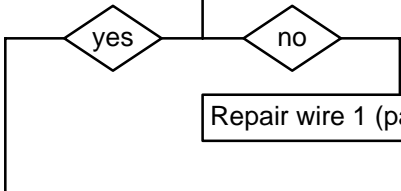
j. NBC SYSTEM CIRCUIT — CONTINUED

(2) NBC SYSTEM DOES NOT OPERATE. — CONTINUED

CONTINUED FROM STEP B

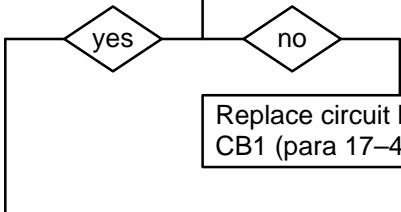
**C** 1. Place one multimeter lead at terminal A of circuit breaker CB1 and other lead at input side of J1 connector on NBC control box assembly.  
2. Check for continuity.

Is continuity present?



Repair wire 1 (para 17-4).

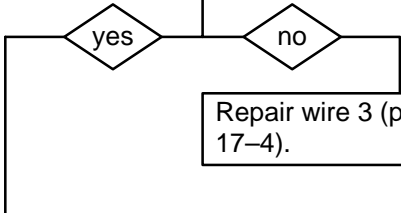
**D**



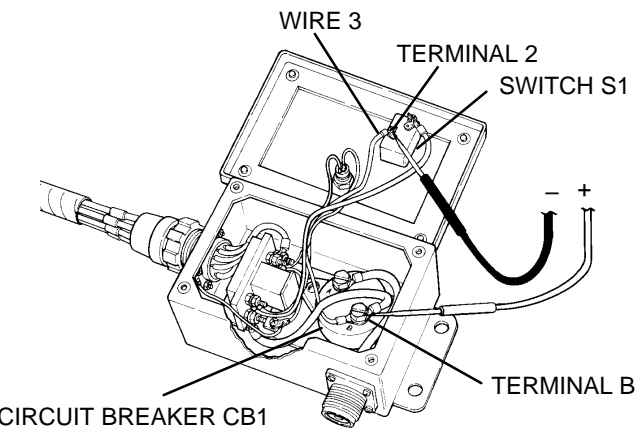
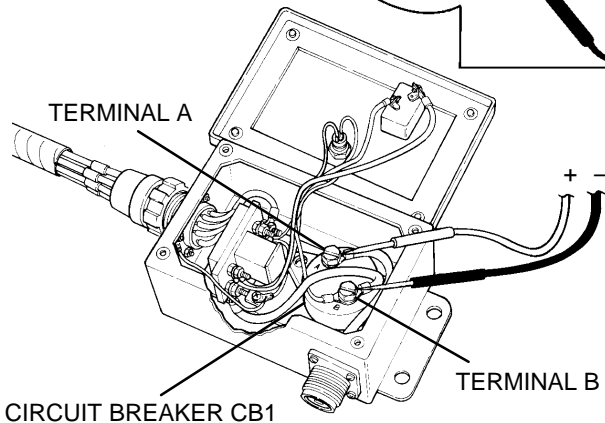
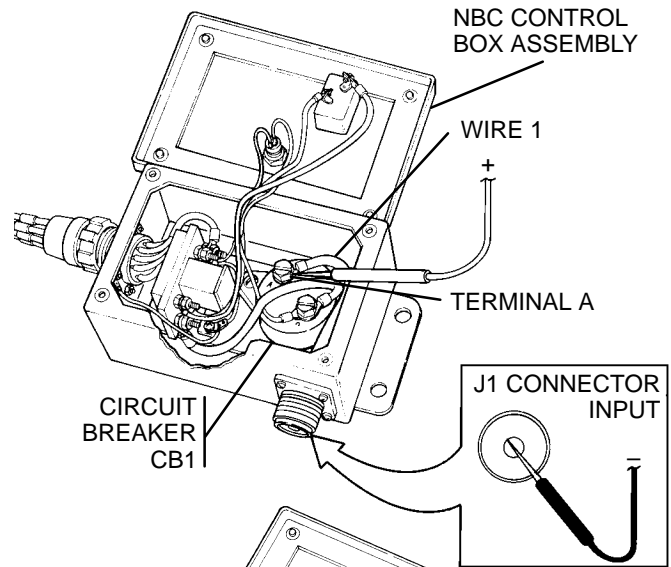
Replace circuit breaker CB1 (para 17-4).

**E** 1. Place one multimeter lead on terminal B of circuit breaker CB1 and other lead on terminal 2 of switch S1.  
2. Check for continuity.

Is continuity present?



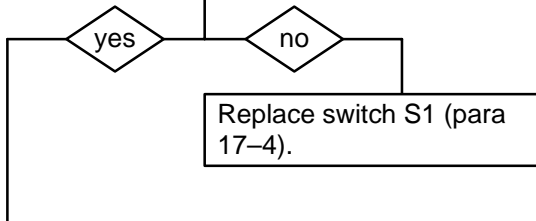
Repair wire 3 (para 17-4).



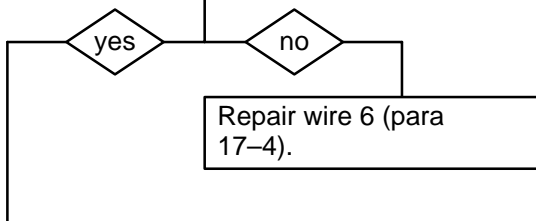
CONTINUED ON NEXT PAGE

CONTINUED FROM STEP E

- F**
1. Turn CAB NBC POWER switch to ON.
  2. Place one multimeter lead on terminal 2 and other lead on terminal 3 of switch S1.
  3. Check for continuity.
- Is continuity present?

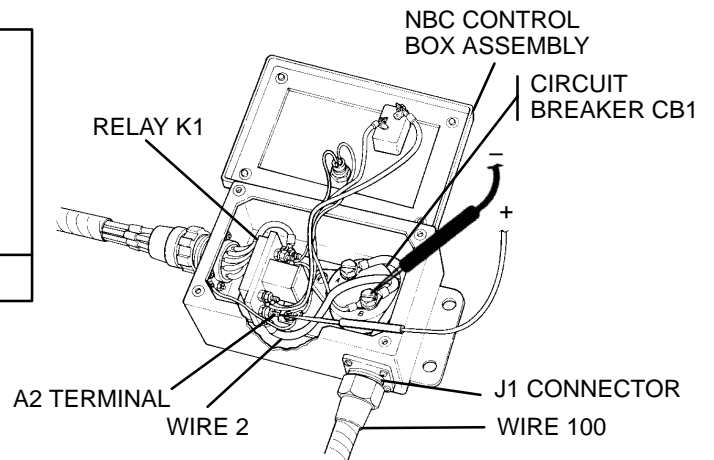
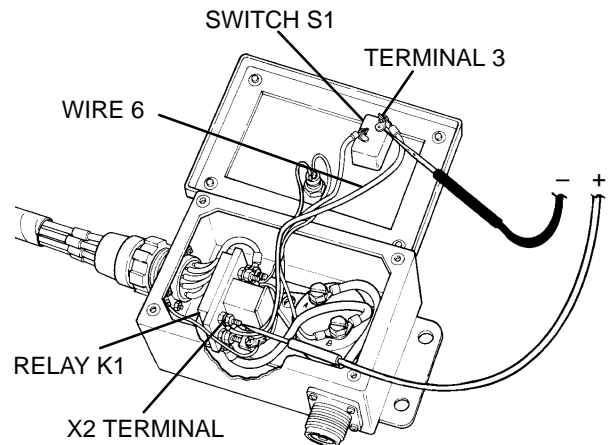
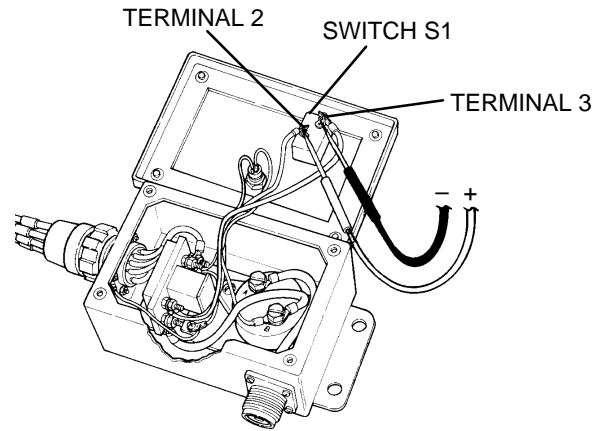


- G**
1. Place one multimeter lead on X2 terminal of electromagnetic relay K1 and other lead on terminal 3 of switch S1.
  2. Check for continuity.
- Is continuity present?



- H**
1. Turn CAB NBC POWER switch to OFF.
  2. Connect wire 100 to J1 connector of NBC control box assembly.
  3. Place one multimeter lead on A2 terminal of electromagnetic relay K1 and other lead to terminal B of circuit breaker CB1.
  4. Check for continuity.
- Is continuity present?

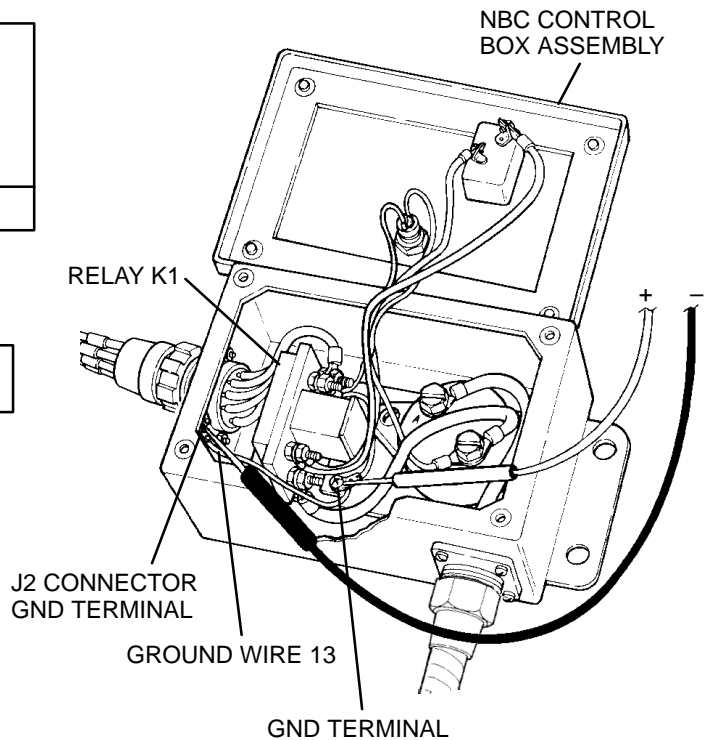
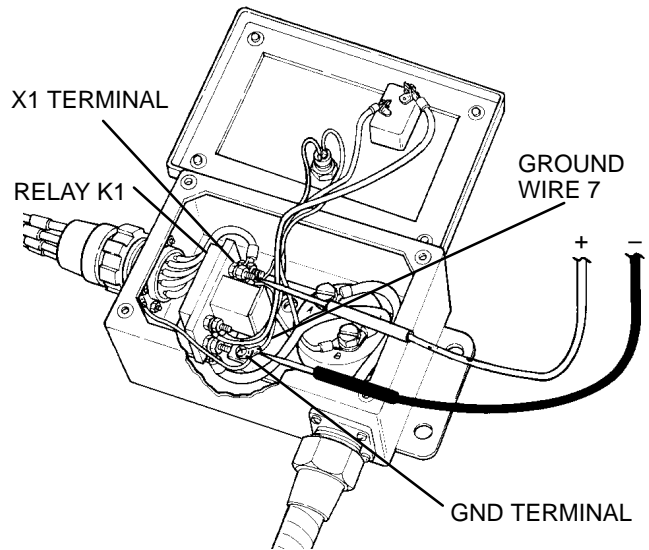
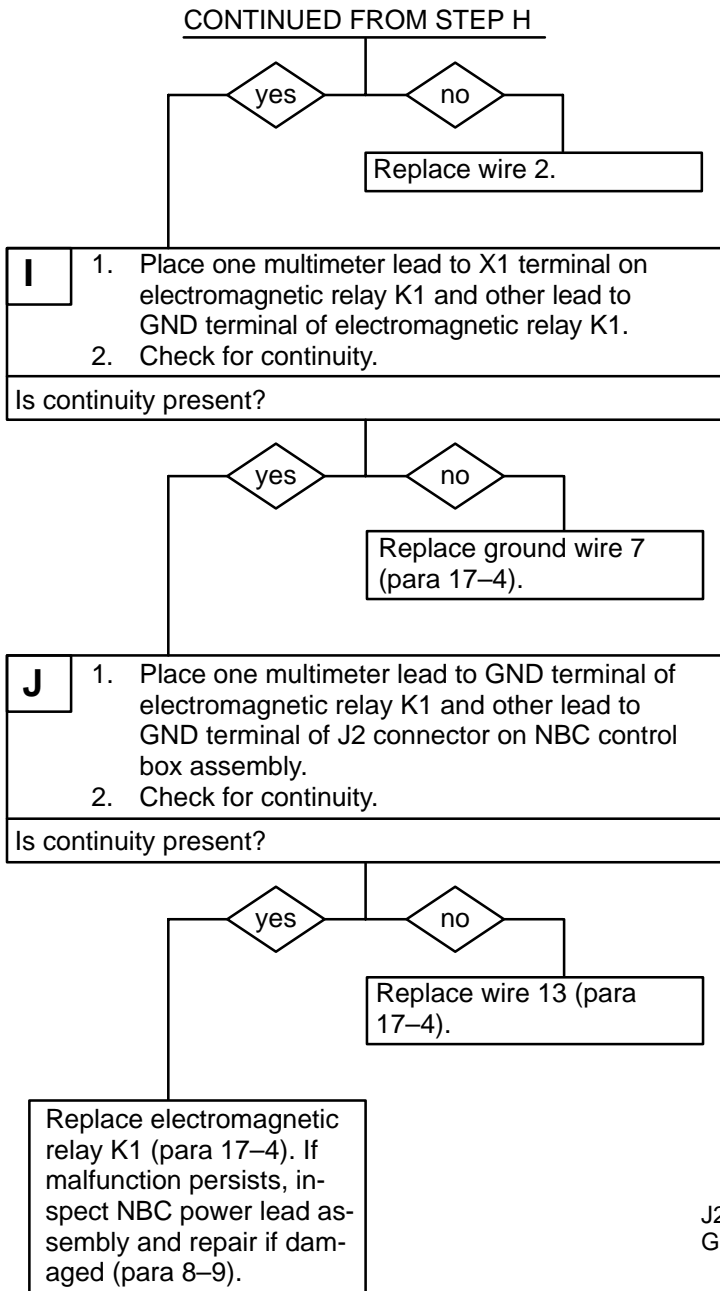
CONTINUED ON NEXT PAGE



3-3 TROUBLESHOOTING — CONTINUED

j. NBC SYSTEM CIRCUIT — CONTINUED

(2) NBC SYSTEM DOES NOT OPERATE.  
— CONTINUED



END OF TASK



j. NBC SYSTEM CIRCUIT — CONTINUED

(3) NBC CONTROL BOX ASSEMBLY INDICATOR LIGHT ILLUMINATES, BUT M2A2 AIR PURIFIER DOES NOT OPERATE.

**INITIAL SETUP**

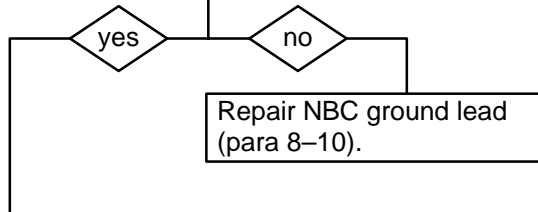
Applicable Configuration  
M109A4/M109A5 howitzers  
Test Equipment  
Multimeter (item 6, Appx H)

Tools  
Artillery and turret mechanic's tool kit  
(SC 5180-95-CL-A12)

Equipment Condition  
Vehicle MASTER switch to OFF (TM 9-2350-311-10)  
CAB NBC POWER switch to OFF (TM 9-2350-311-10)

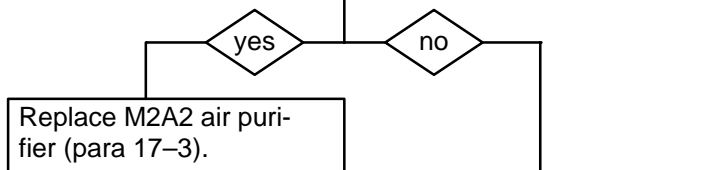
**A** 1. Place one multimeter lead on one end of NBC ground lead that connects to M2A2 air purifier and other lead on NBC ground lead that connects to M27 periscope.  
2. Check for continuity.

Is continuity present?

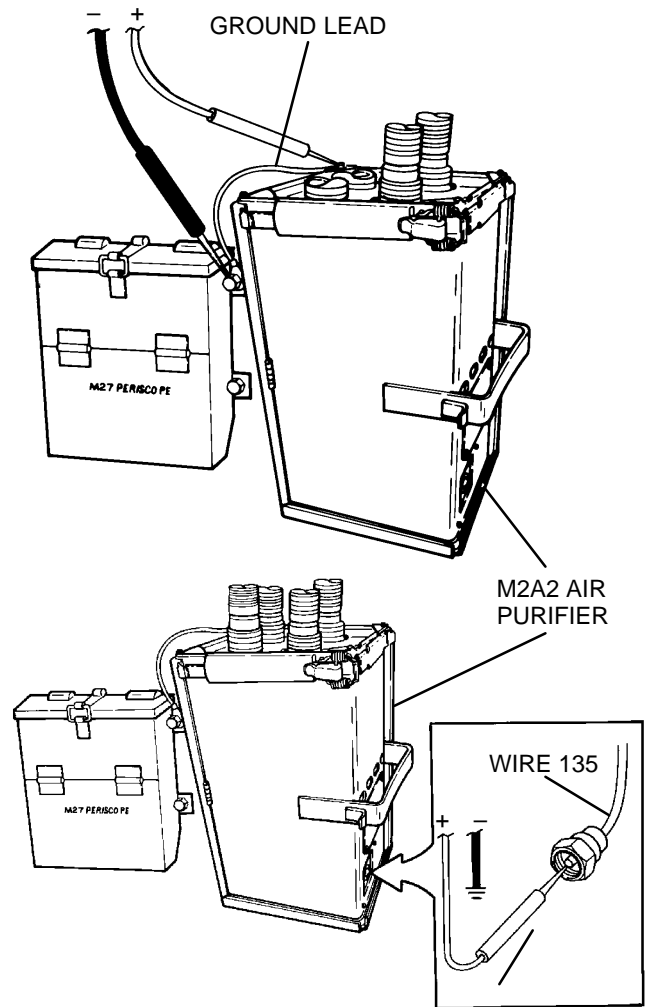


**B** 1. Disconnect wire 135 from M2A2 air purifier.  
2. Turn MASTER and CAB NBC POWER switches to ON.  
3. Place red multimeter lead in wire 135 and black lead to ground.  
4. Check for voltage.

Is battery voltage present?



CONTINUED ON NEXT PAGE



3-3 TROUBLESHOOTING — CONTINUED

j. NBC SYSTEM CIRCUIT — CONTINUED

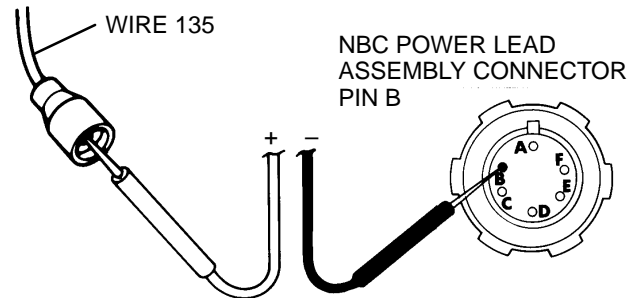
(3) NBC CONTROL BOX ASSEMBLY INDICATOR LIGHT ILLUMINATES, BUT M2A2 AIR PURIFIER DOES NOT OPERATE. — CONTINUED

CONTINUED FROM STEP B

**C**

1. Turn MASTER and CAB NBC POWER switches to OFF.
2. Disconnect NBC power lead assembly at J2 connector of NBC control box assembly.
3. Place one multimeter lead in wire 135 and other lead to pin B of NBC power lead assembly connector.
4. Check for continuity.

Is continuity present?



yes

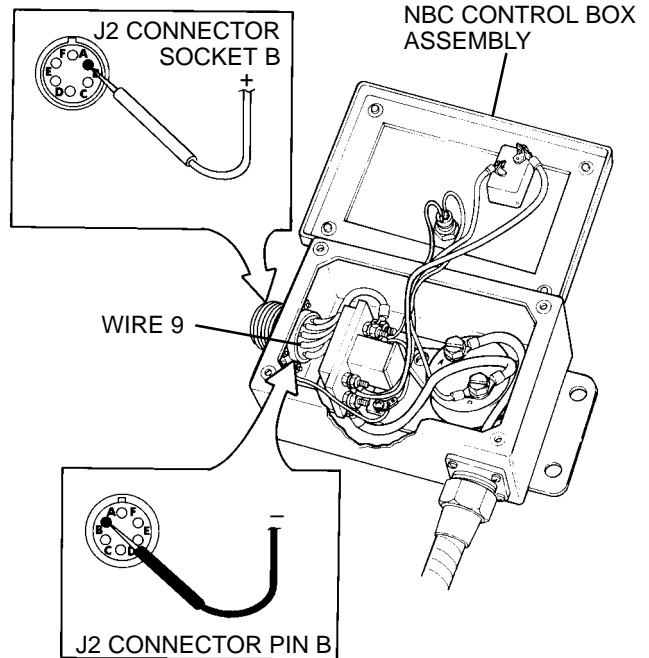
no

Repair wire 135 of NBC power lead assembly (para 8-9).

**D**

1. Reconnect lead 135 to M2A2 air purifier.
2. Place one multimeter lead in socket B and other lead to pin B of J2 connector on NBC control box assembly.
3. Check for continuity.

Is continuity present?



yes

no

Replace J2 connector of NBC control box assembly (para 17-4).

Repair wire 9 (para 17-4).

END OF TASK

j. NBC SYSTEM CIRCUIT — CONTINUED

- (4) NBC CONTROL BOX ASSEMBLY INDICATOR LIGHT ILLUMINATES, BUT GUNNER'S M3 ELECTRICAL AIR HEATER DOES NOT OPERATE.

**INITIAL SETUP**

Applicable Configuration  
M109A4/M109A5 howitzers

Test Equipment  
Multimeter (item 6, Appx H)

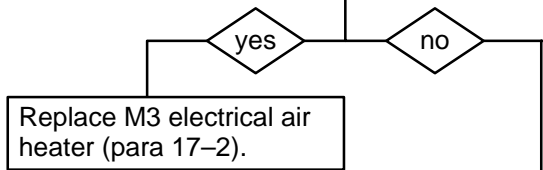
Tools  
Artillery and turret mechanic's tool kit  
(SC 5180-95-CL-A12)

Equipment Condition  
Vehicle MASTER switch to OFF (TM 9-2350-311-10)  
CAB NBC POWER switch to OFF (TM 9-2350-311-10)

**A**

1. Disconnect wire 136A from gunner's M3 electrical air heater.
2. Turn MASTER and CAB NBC POWER switches to ON.
3. Place red multimeter lead in wire 136A and black lead to ground.
4. Check for voltage.

Is battery voltage present?

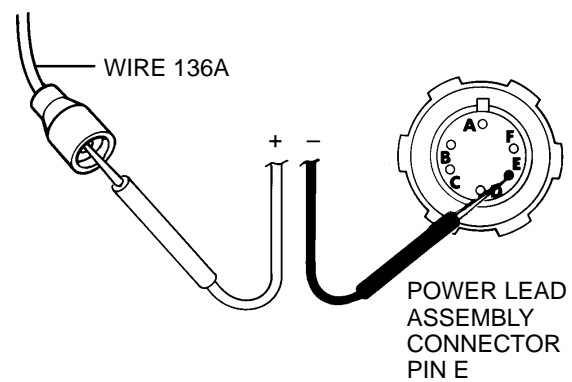
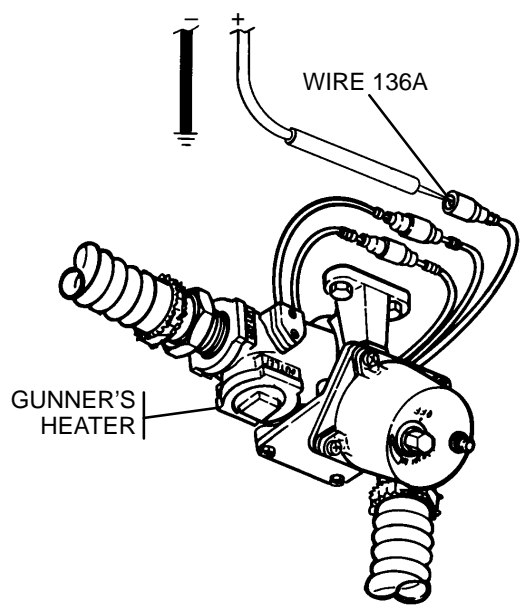


**B**

1. Turn MASTER and CAB NBC POWER switches to OFF.
2. Disconnect NBC power lead assembly at J2 connector of NBC control box assembly.
3. Place one multimeter lead in wire 136A and other lead to pin E of NBC power lead assembly connector.
4. Check for continuity.

Is continuity present?

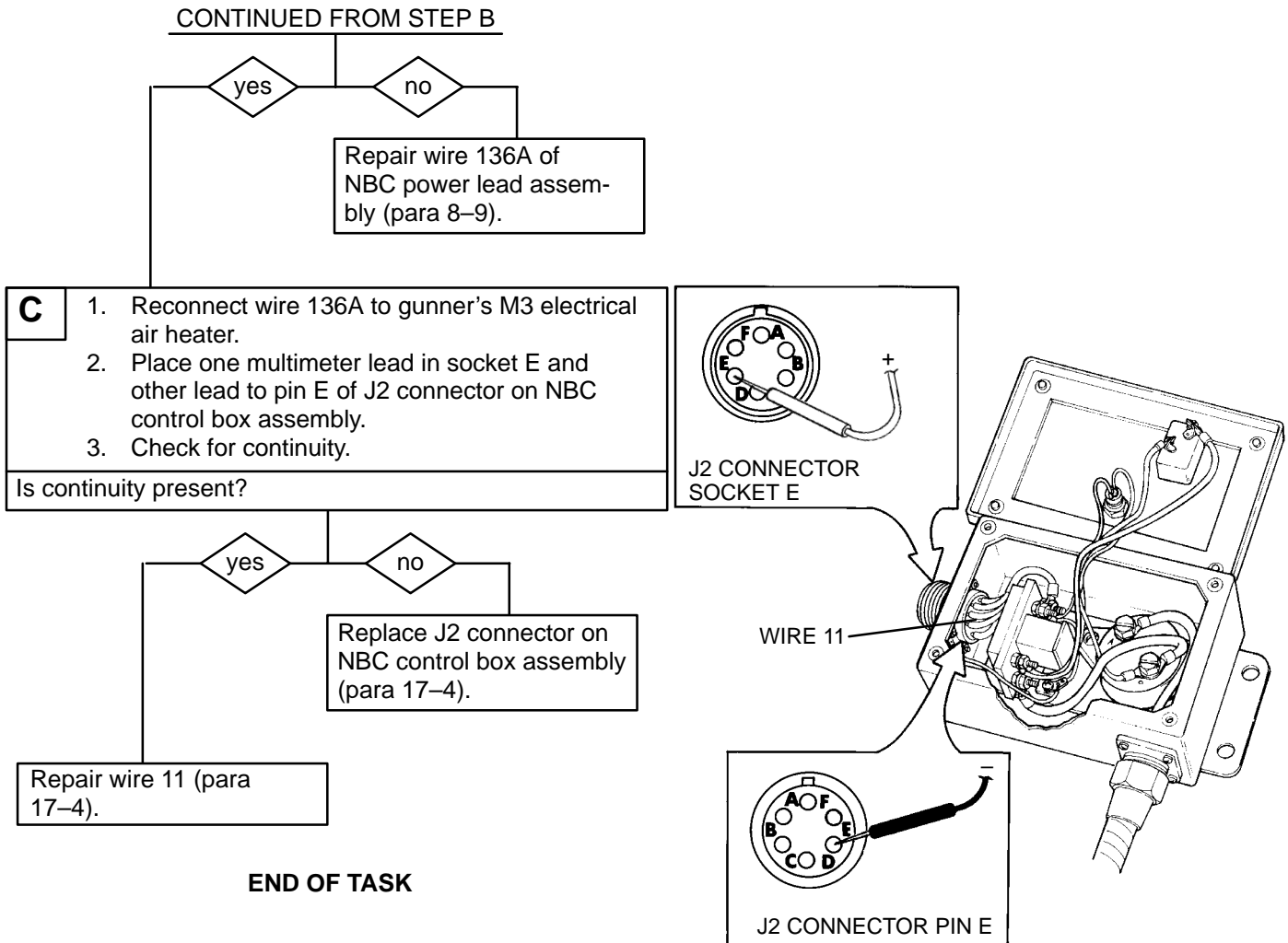
CONTINUED ON NEXT PAGE



3-3 TROUBLESHOOTING — CONTINUED

j. NBC SYSTEM CIRCUIT — CONTINUED

(4) NBC CONTROL BOX ASSEMBLY INDICATOR LIGHT ILLUMINATES, BUT GUNNER'S M3 ELECTRICAL AIR HEATER DOES NOT OPERATE. — CONTINUED



j. NBC SYSTEM CIRCUIT — CONTINUED

- (5) NBC CONTROL BOX ASSEMBLY INDICATOR LIGHT ILLUMINATES, BUT CANNONEER NO. 1'S M3 ELECTRICAL AIR HEATER DOES NOT OPERATE.

**INITIAL SETUP**

Applicable Configuration

M109A4/M109A5 howitzers

Test Equipment

Multimeter (item 6, Appx H)

Tools

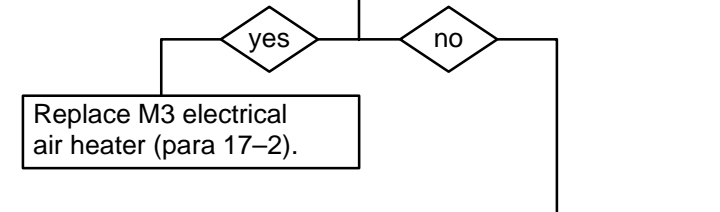
Artillery and turret mechanic's tool kit  
(SC 5180-95-CL-A12)

Equipment Condition

Vehicle MASTER switch to OFF (TM 9-2350-311-10)  
CAB NBC POWER switch to OFF (TM 9-2350-311-10)

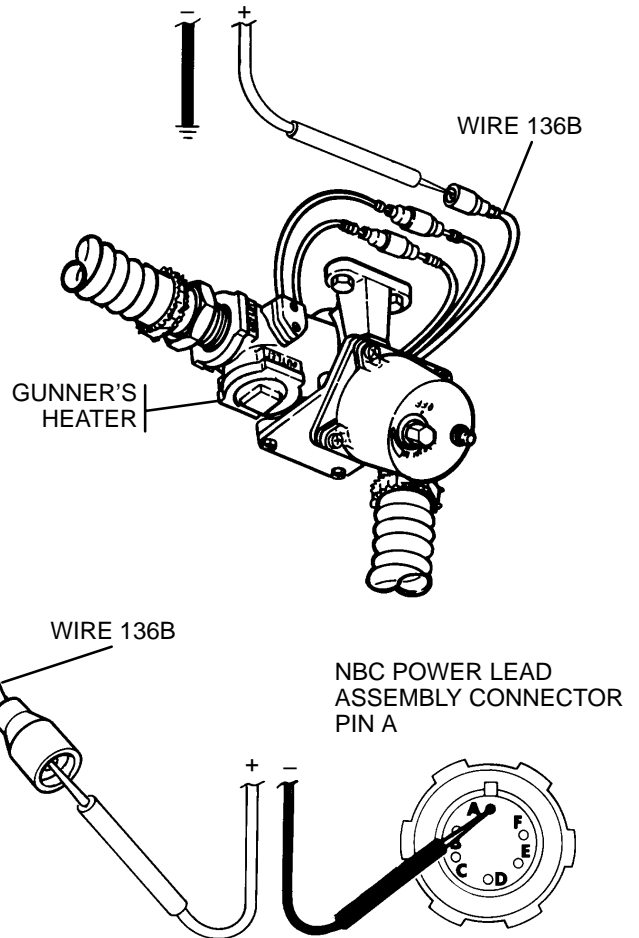
- A**
1. Disconnect lead 136B from cannoneer no. 1's M3 electrical air heater.
  2. Turn MASTER and CAB NBC POWER switches to ON.
  3. Place red multimeter lead in wire 136B and black lead to ground.
  4. Check for voltage.

Is battery voltage present?



- B**
1. Turn MASTER and CAB NBC POWER switches to OFF.
  2. Disconnect NBC power lead assembly at J2 connector on NBC control box assembly.
  3. Place one multimeter lead in wire 136B and other lead to pin A of NBC power lead assembly connector.
  4. Check for continuity.

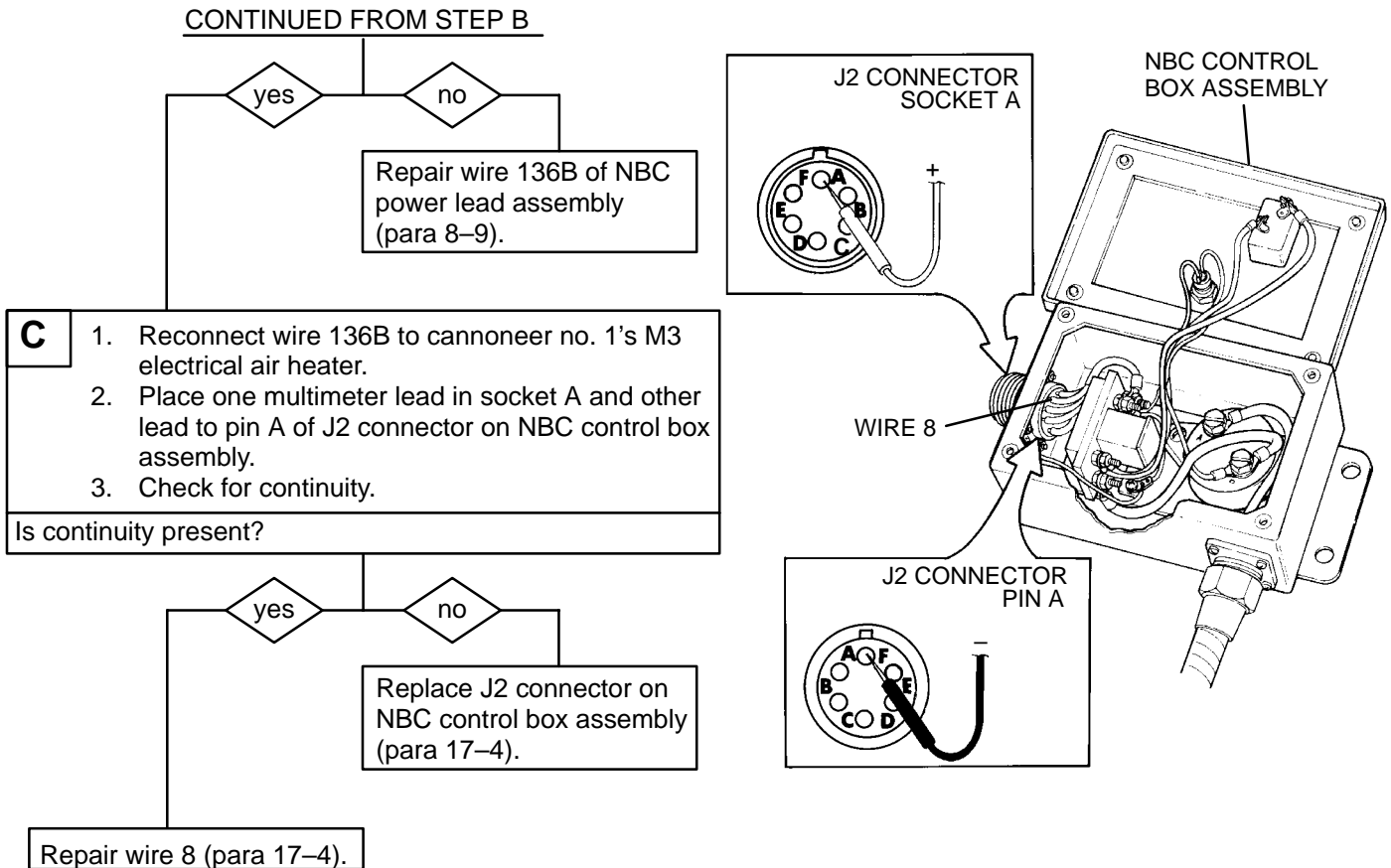
CONTINUED ON NEXT PAGE



3-3 TROUBLESHOOTING — CONTINUED

j. NBC SYSTEM CIRCUIT — CONTINUED

(5) NBC CONTROL BOX ASSEMBLY INDICATOR LIGHT ILLUMINATES, BUT CANNONEER NO. 1'S M3 ELECTRICAL AIR HEATER DOES NOT OPERATE. — CONTINUED



END OF TASK

j. NBC SYSTEM CIRCUIT — CONTINUED

- (6) NBC CONTROL BOX ASSEMBLY INDICATOR LIGHT ILLUMINATES, BUT SECTION CHIEF'S M3 ELECTRICAL AIR HEATER DOES NOT OPERATE.

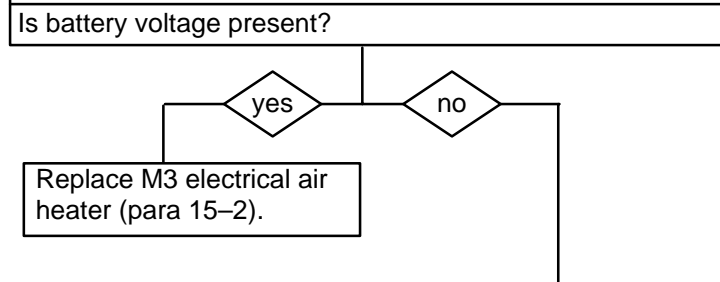
**INITIAL SETUP**

Applicable Configuration  
M109A4/M109A5 howitzers  
Test Equipment  
Multimeter (item 6, Appx H)

Tools  
Artillery and turret mechanic's tool kit  
(SC 5180-95-CL-A12)

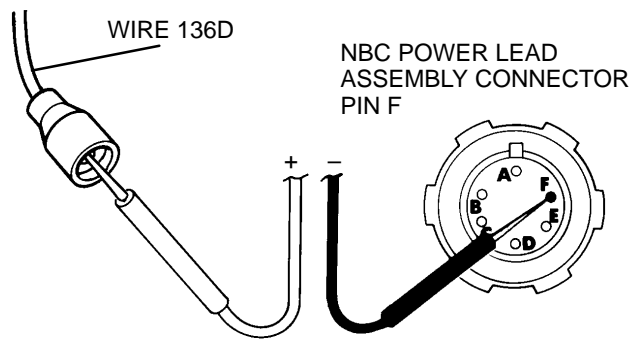
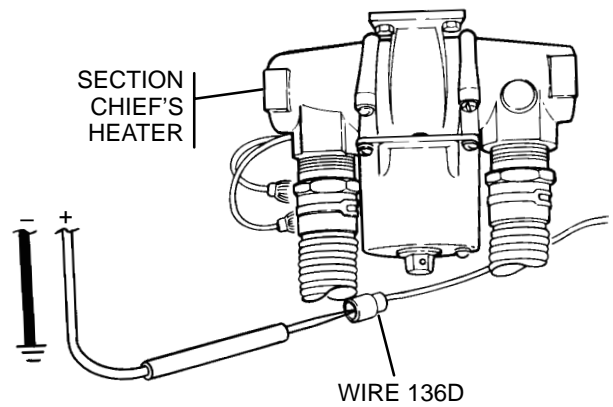
Equipment Condition  
Vehicle MASTER switch to OFF (TM 9-2350-311-10)  
CAB NBC POWER switch to OFF (TM 9-2350-311-10)

- A**
1. Disconnect wire 136D from section chief's M3 electrical air heater.
  2. Turn MASTER and CAB NBC POWER switches to ON.
  3. Place red multimeter lead in wire 136D and black lead to ground.
  4. Check for voltage.



- B**
1. Turn MASTER and CAB NBC POWER switches to OFF.
  2. Disconnect NBC power lead assembly at J2 connector on NBC control box assembly.
  3. Place red multimeter lead connector of wire 136D and black lead to pin F of NBC power lead assembly connector.
  4. Check for continuity.

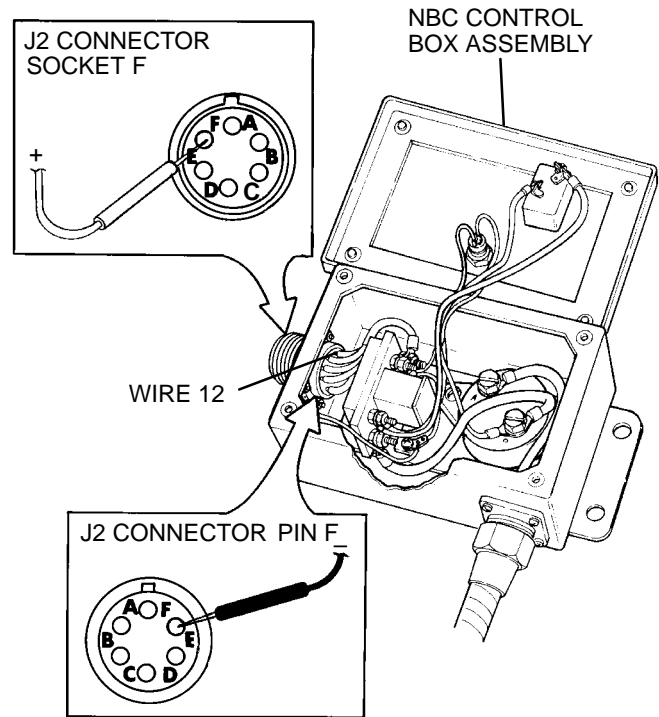
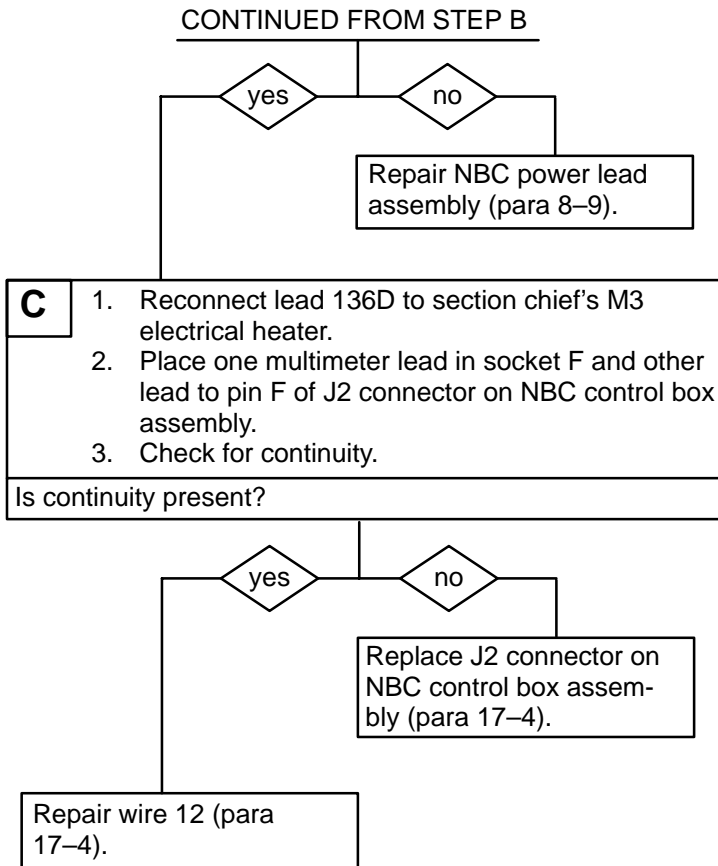
CONTINUED ON NEXT PAGE



3-3 TROUBLESHOOTING — CONTINUED

j. NBC SYSTEM CIRCUIT — CONTINUED

(6) NBC CONTROL BOX ASSEMBLY INDICATOR LIGHT ILLUMINATES, BUT SECTION CHIEF'S M3 ELECTRICAL AIR HEATER DOES NOT OPERATE. — CONTINUED



END OF TASK



j. NBC SYSTEM CIRCUIT — CONTINUED

- (7) NBC CONTROL BOX ASSEMBLY INDICATOR LIGHT ILLUMINATES, BUT ASSISTANT GUNNER'S M3 ELECTRICAL HEATER DOES NOT OPERATE.

**INITIAL SETUP**

Applicable Configuration

M109A4/M109A5 howitzers

Test Equipment

Multimeter (item 6, Appx H)

Tools

Artillery and turret mechanic's tool kit  
(SC 5180-95-CL-A12)

Equipment Condition

Vehicle MASTER switch to OFF (TM 9-2350-311-10)  
CAB NBC POWER switch to OFF (TM 9-2350-311-10)

- A**
1. Disconnect wire 136C from assistant gunner's M3 electrical heater.
  2. Turn MASTER and CAB NBC POWER switches to ON.
  3. Place red multimeter lead in wire 136C and black multimeter lead to ground.
  4. Check for voltage.

Is battery voltage present?

yes

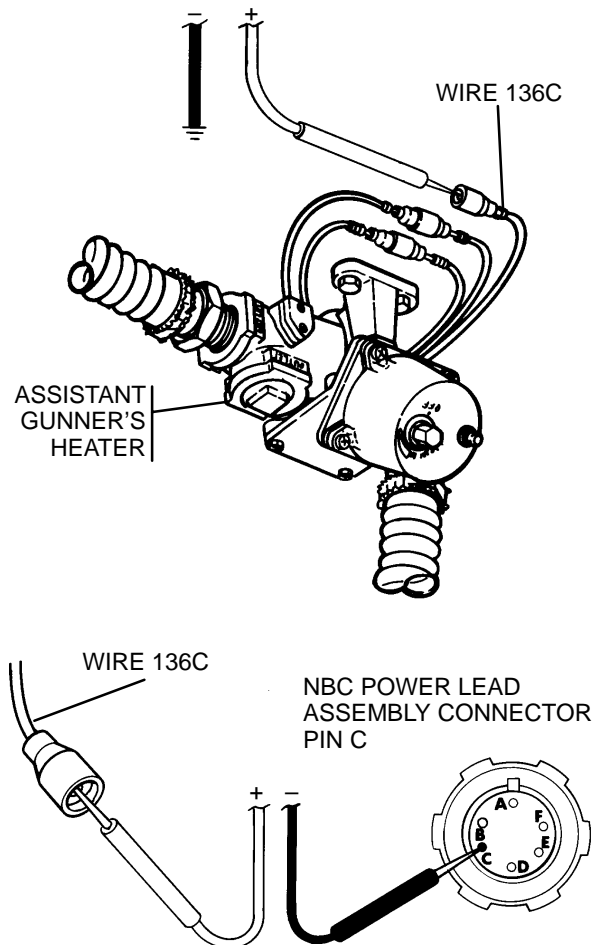
no

Replace M3 electrical air heater (para 17-2).

- B**
1. Turn MASTER and CAB NBC POWER switches to OFF.
  2. Disconnect NBC power lead assembly at J2 connector on NBC control box assembly.
  3. Place one multimeter lead in wire 136C and other lead to pin C of NBC power lead assembly connector.
  4. Check for continuity.

Is continuity present?

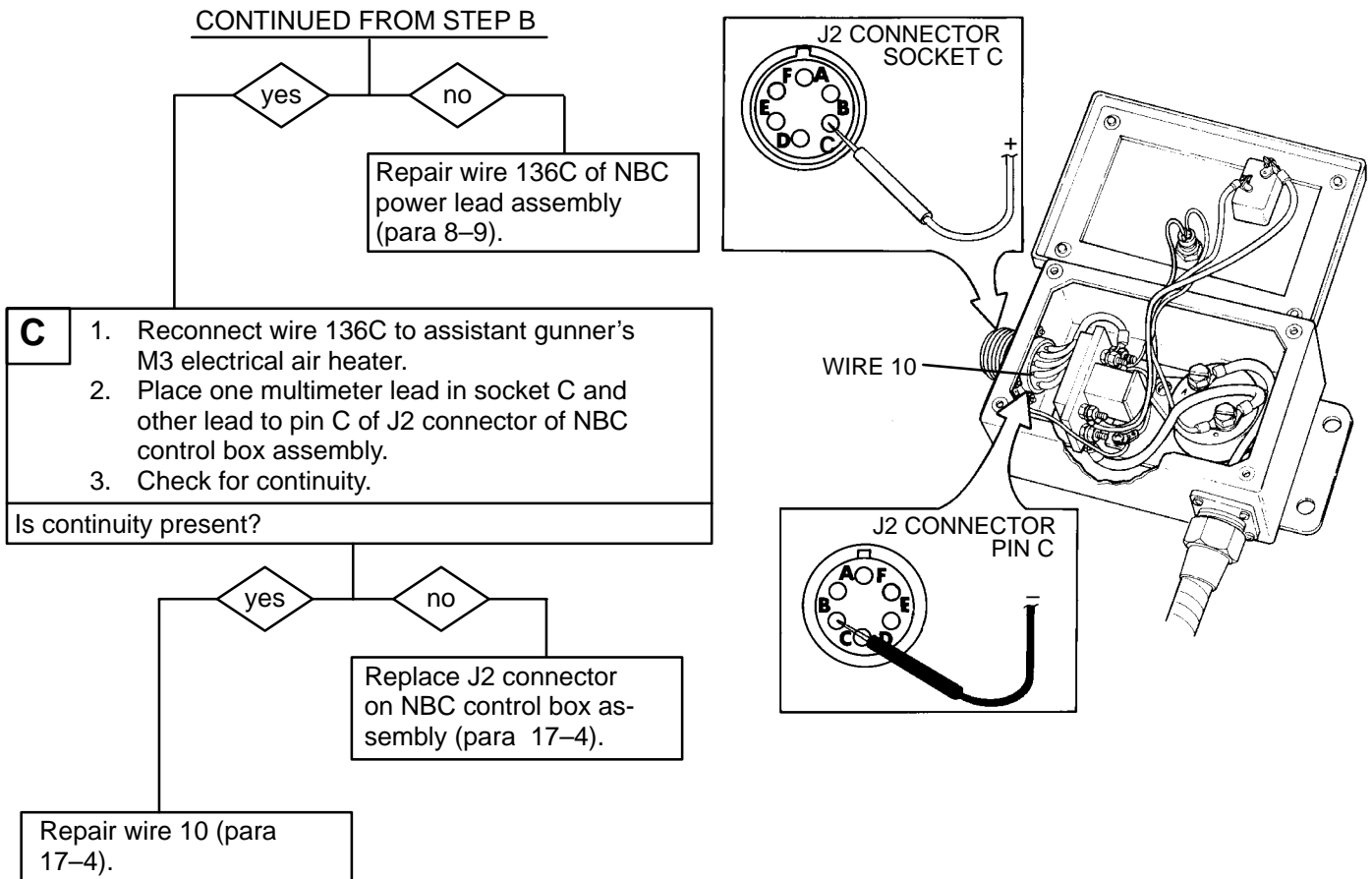
CONTINUED ON NEXT PAGE



3-3 TROUBLESHOOTING — CONTINUED

j. NBC SYSTEM CIRCUIT — CONTINUED

(7) NBC CONTROL BOX ASSEMBLY INDICATOR LIGHT ILLUMINATES, BUT ASSISTANT GUNNER'S M3 ELECTRICAL HEATER DOES NOT OPERATE. — CONTINUED



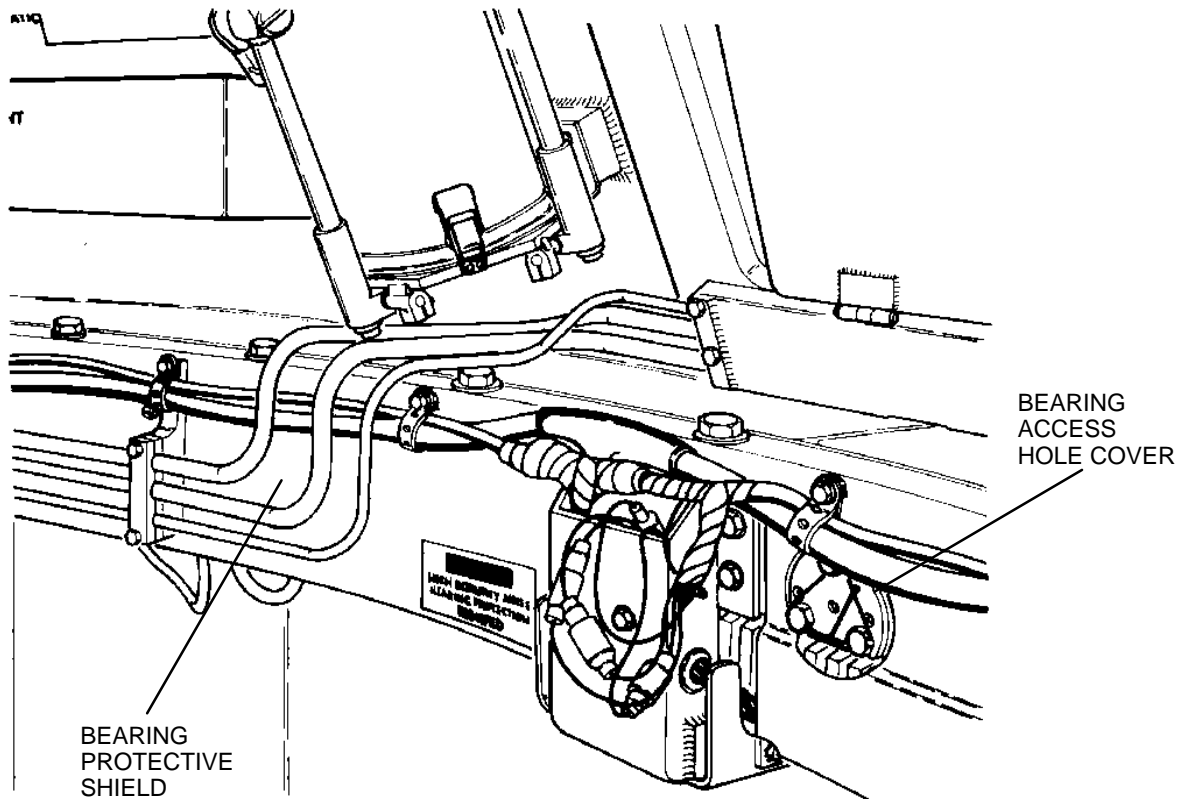
END OF TASK

## CHAPTER 4 BEARING PROTECTIVE SHIELDS AND BEARING/RACE RING ASSEMBLY

### GENERAL

This chapter details the removal and installation of the bearing protective shields and provides instructions on how to inspect the cab bearing assembly.

CONTENTS	Page
4-1 TURRET (CAB) BEARING PROTECTIVE SHIELDS .....	4-2
4-2 BEARING/RACE RING ASSEMBLY .....	4-4



## 4-1 TURRET (CAB) BEARING PROTECTIVE SHIELDS

This task covers: a. Removal b. Installation

### INITIAL SETUP

Tools

Artillery and turret mechanic's tool kit  
(SC 5180-95-CL-A12)

Materials/Parts

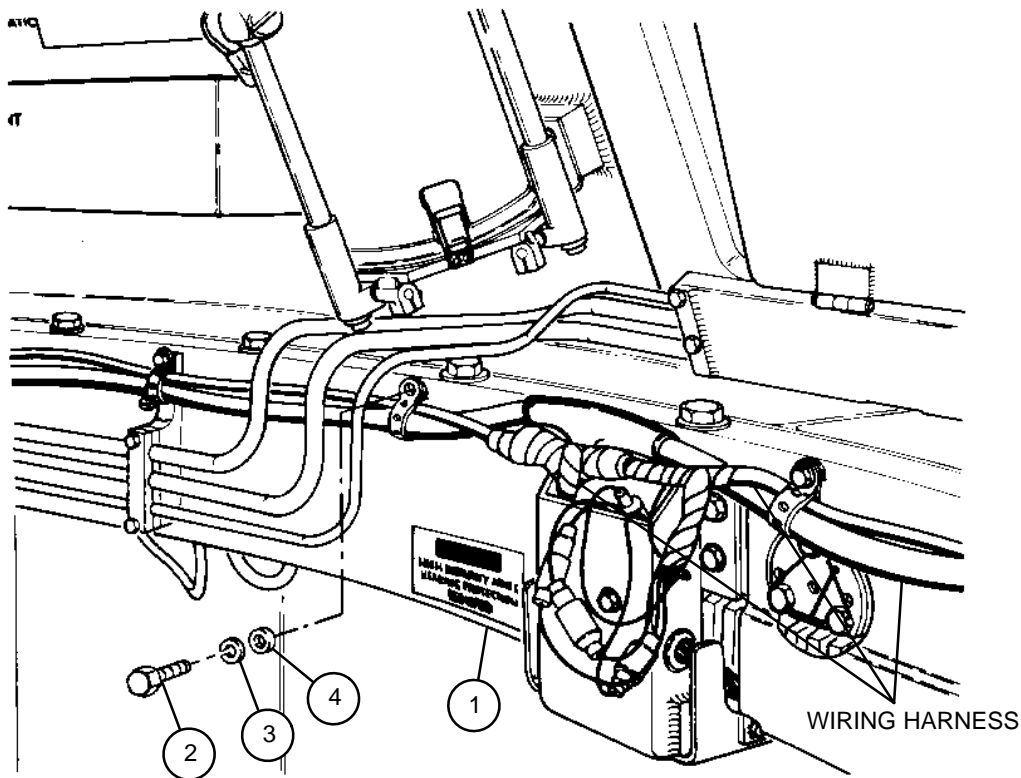
Lockwashers (20 or 23) (item 86, Appx G)

#### a. Removal

#### NOTE

- Tag all protective shields before removal for identification during installation.
- Vehicles with 3-contact arms have two 3-hole and two 7-hole protective shields. Vehicles with 5-contact arms have three 3-hole and two 7-hole protective shields.

- 1 Remove protective shields (1) by removing three cap screws (2), three lockwashers (3) and three flat washers (4) for each protective shield. Discard lockwashers.
- 2 Pull protective shields (1) down and out to remove.
- 3 Replace three cap screws (2) and three flat washers (4) for each protective shield in their original cab holes to support wiring harnesses.



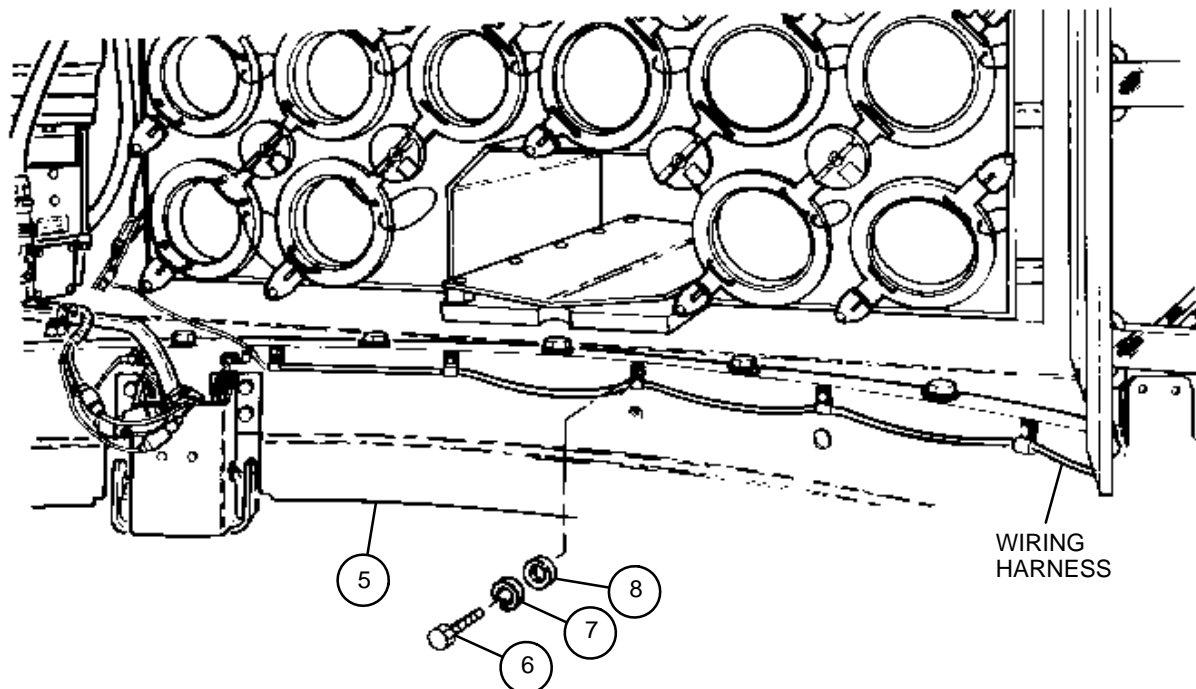
- 4 Remove two protective shields (5) by removing seven cap screws (6), seven lockwashers (7), and seven flat washers (8) for each protective shield. Discard lockwashers.
- 5 Pull protective shields (5) down and out to remove.
- 6 Replace seven cap screws (6) and seven flat washers (8) in their original cab holes to support wiring harnesses.

## b. Installation

### NOTE

Make sure that the wiring harnesses hang on the outside of the protective shields when the protective shields are being installed. Re-attach the wiring harnesses when installing the protective shields.

- 1 Remove seven cap screws (6) and seven flat washers (8) supporting wiring harness. Install one protective shield (5) and secure wiring harness to protective shield with seven flat washers (8), seven new lockwashers (7), and seven cap screws (6). Repeat procedure for second protective shield.
- 2 Remove three cap screws (2) and three flat washers (4) supporting wiring harness. Install one protective shield (1) and secure wiring harness to protective shield with three flat washers (4), three new lockwashers (3), and three cap screws (2).
- 3 Repeat step 2 until all protective shields (1) have been installed.



---

## 4-2 BEARING\ RACE RING ASSEMBLY

---

This task covers: Inspection

---

### **INITIAL SETUP**

#### Tools

Artillery and turret mechanic's tool kit  
(SC 5180-95-CL-A12)

#### Materials/Parts

Lockwire (item 32, Appx G)  
Lockwire (item 33, Appx G)

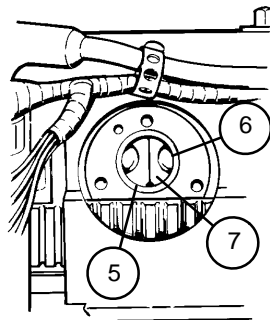
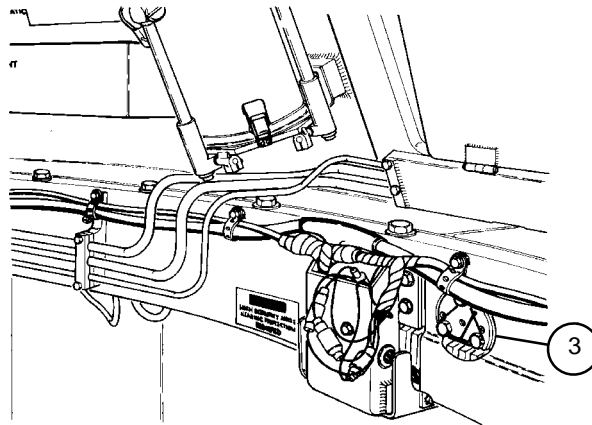
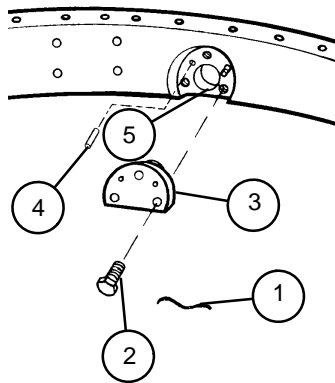
---

### **NOTE**

- Bearing\race ring assembly components vary between vehicles.
- Vehicles with five contact arm assemblies have bearing assemblies with these characteristics:
  - Number of bearing balls is 212.
  - 212 bearing balls are separated by 106 race ring spacers.
- Not all vehicles with three contact arm assemblies have same race ring assembly components. Some vehicles have 212 bearing balls mounted on 106 race ring spacers. Other vehicles have 213 bearing balls mounted on 213 helical compression springs. When maintenance inspections call for replacement of bearing balls, helical compression springs are replaced by race ring spacers.
- Vehicles having three contact arm assemblies (which have not had helical compression springs replaced by race ring spacers) have these characteristics:
  - Number of bearing balls is 213.
  - 213 bearing balls are separated by 213 helical compression springs.
- Unit maintenance has the responsibility for lubricating the bearing\race ring assembly (para 2-9).

### **Inspection**

- 1 Cut lockwire (1) to remove. Discard lockwire.
- 2 Remove three cap screws (2) and ball turret cover (3).
- 3 Replace headless straight pin (4), if damaged.
- 4 Manually traverse cab and look through access hole (5).
- 5 When looking through access hole (5), inspect bearing balls (6) and race ring spacers (7) or helical compression springs (not shown) for damage or wear. If bearing balls, race ring spacers or helical compression springs need replacing, notify support maintenance.
- 6 If grease on bearing\race ring assembly contains dirt or sand, notify support maintenance. Race ring seal (hidden) could be damaged.
- 7 After inspecting bearing balls (6), race ring spacers (7) or helical compression springs (not shown) for the entire 6400 mil traverse, install ball turret cover (3), three cap screws (2) and new lockwire (1).







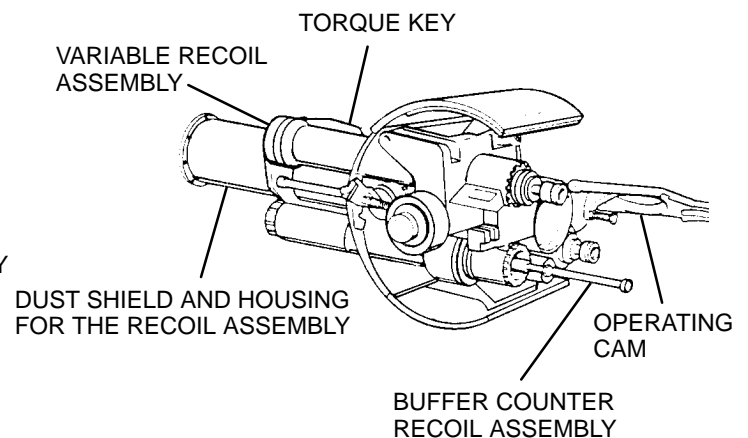
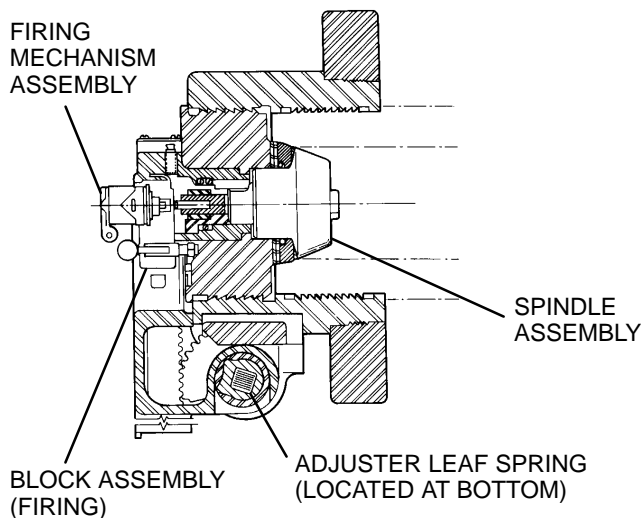
## CHAPTER 5 MOUNT AND HOWITZER ASSEMBLY

### GENERAL

This chapter provides maintenance instructions for the 155MM howitzer cannon and mount. The M109A5 howitzer contains the M182 mount and the M284 cannon. M109A2/M109A3/M109A4 howitzers contain the M178 mount and the M185 cannon. The differences between the two configurations are not extensive (para 1-15). Therefore, only specific differences in the overall configurations shall be noted within maintenance procedures.

### CONTENTS

	<u>Page</u>
5-1	THRUST COLLAR, BORE EVACUATOR 11578384, AND BORE EVACUATOR
	THRUST COLLARS ..... 5-2
5-2	FIRING MECHANISM ASSEMBLY, M35 (M185 CANNON) ..... 5-3
5-3	FIRING MECHANISM ASSEMBLY, M49 (M284 CANNON) ..... 5-5
5-4	FIRING MECHANISM HOUSING ..... 5-8
5-5	FIRING BLOCK ASSEMBLY AND FOLLOWER ASSEMBLY ..... 5-9
5-6	ADJUSTER LEAF SPRING ..... 5-11
5-7	SPINDLE ASSEMBLY ..... 5-14
5-8	BREECHBLOCK ASSEMBLY ..... 5-20
5-9	CARRIER ASSEMBLY ..... 5-21
5-10	TORQUE KEY ..... 5-29
5-11	DAMPER ASSEMBLY ..... 5-31
5-12	OPERATING CAM ..... 5-32
5-13	DUST SHIELD AND VARIABLE RECOIL ACCESS COVER ..... 5-36
5-14	M42 PERISCOPE COVER DOOR ..... 5-40
5-15	M140 ALINEMENT DEVICE MOUNT ACCESS COVER ..... 5-41
5-16	RECUPERATOR COVER ..... 5-42
5-17	BUFFER ASSEMBLY ..... 5-43
5-18	ACCESS COVER (M182 MOUNT) ..... 5-46
5-19	REPLENISHER ACCUMULATOR ASSEMBLY ..... 5-47
5-20	RADAR ANTENNA BRACKET ..... 5-54
5-21	CRADLE AND HOWITZER ACCESS COVERS ..... 5-55
5-22	DIRECT FIRE RANGE PLATE ..... 5-58



## 5-1 THRUST COLLAR, BORE EVACUATOR 11578384, AND BORE EVACUATOR THRUST COLLARS

This task covers: a. Disassembly b. Inspection  
c. Assembly

### INITIAL SETUP

Tools

Artillery and turret mechanic's tool kit  
(SC 5180-95-CL-A12)

Equipment Condition

Muzzle brake removed (TM 9-2350-311-10)  
Thrust collar removed (TM 9-2350-311-10)  
Bore evacuator removed (TM 9-2350-311-10)

References

TM 9-2350-311-10

#### a. Disassembly

#### NOTE

Setscrews for both thrust collars are staked in three places on the side with spring and detent ball only.

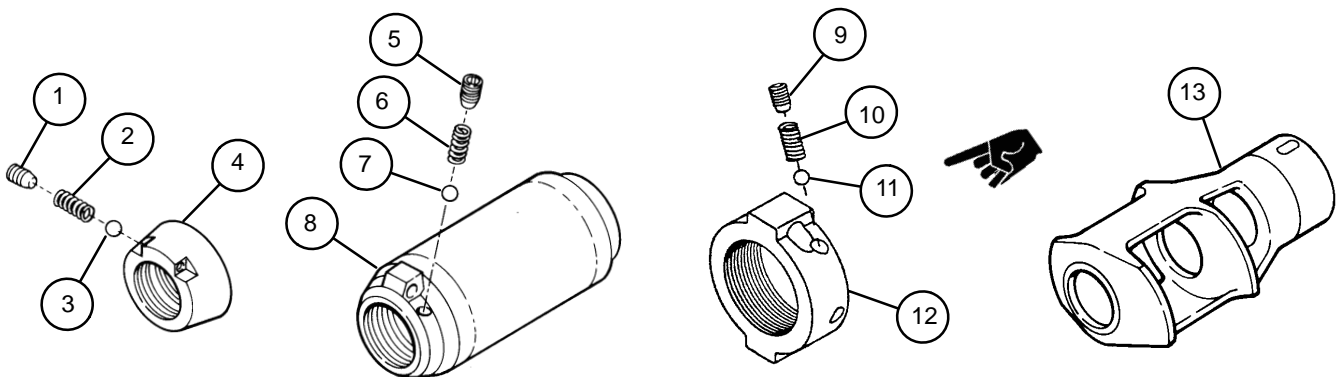
- 1 Remove setscrew (1), spring (2), and bearing ball (3) from thrust collar (4).
- 2 Remove setscrew (5), spring (6), and bearing ball (7) from bore evacuator (8).
- 3 Remove setscrew (9), spring (10), and detent ball (11) from bore evacuator assembly thrust collar (12).

#### b. Inspection

- 1 Inspect bore evacuator (8) for cracks. Replace if cracked.
- 2 Inspect muzzle brake (13) for cracks. Replace if cracks exceed 1 inch (2.54 cm).

#### c. Assembly

- 1 Install detent ball (11), spring (10), and setscrew (9) in bore evacuator assembly thrust collar (12). Stake set-screw in three places.
- 2 Install bearing ball (7), spring (6), and setscrew (5) in bore evacuator (8). Stake setscrew in three places.
- 3 Install bearing ball (3), spring (2), and setscrew (1) in thrust collar (4). Stake setscrew in three places.

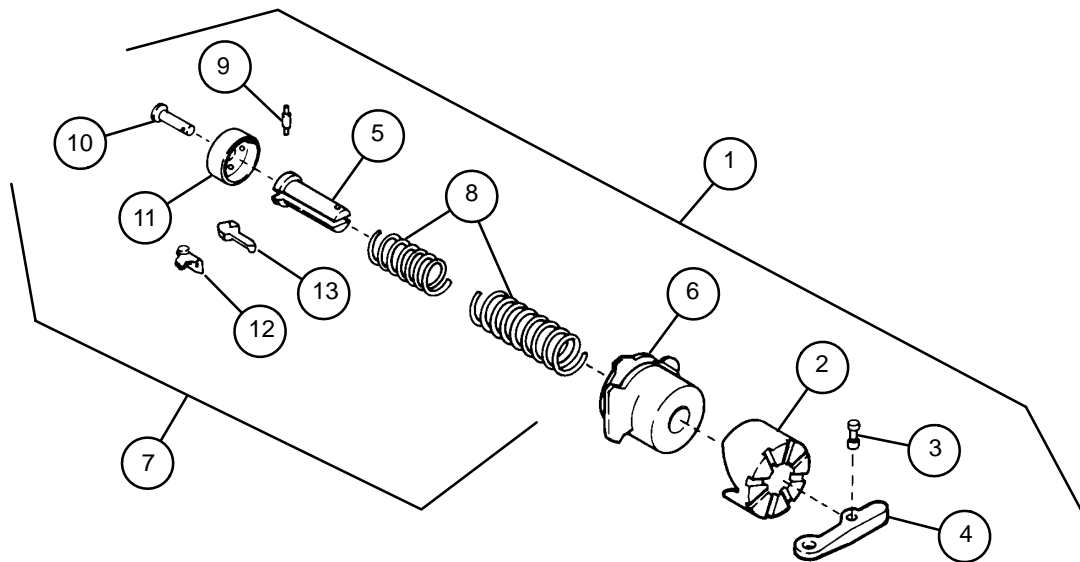




## 5-2 FIRING MECHANISM ASSEMBLY, M35 (M185 CANNON) — CONTINUED

### c. Assembly

- 1 Install firing hammer (10) in hammer guide cup (11).
- 2 Install firing spring (12) and sear (13) on rod end clevis (5).
- 3 Install grooved pin (9) in rod end clevis (5).
- 4 Install two springs (8), case (6), and follower (2) over rod end clevis (5).
- 5 Place assembled firing mechanism (1) components on solid surface.
- 6 Compress springs (8) by pressing follower (2) over rod end clevis (5) until manual control lever (4) can be inserted into rod end clevis.
- 7 Install grooved pin (3) into rod end clevis (5).





---

## 5-3 FIRING MECHANISM ASSEMBLY, M49 (M284 CANNON) — CONTINUED

---

### a. Disassembly — Continued

- 5 Remove two springs (10 and 11), sleeve bushing (12), and spring (13).

#### NOTE

Firing mechanism contains three bearing balls. Be careful that bearing balls are not lost during disassembly.

- 6 Separate hammer guide yoke (5), three bearing balls (14), firing hammer (15), and access cover (16).

### b. Inspection

Inspect for broken, burred, and missing parts. Replace as required.

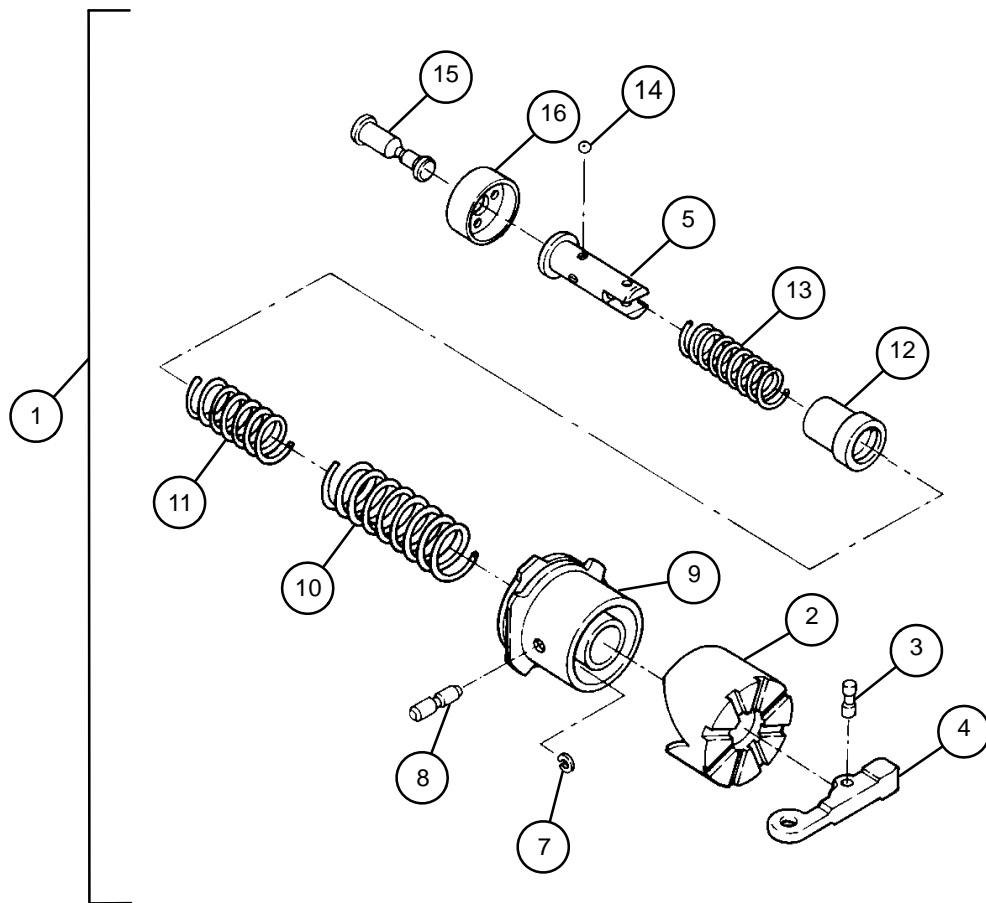
### c. Assembly

- 1 Install firing hammer (15) in access cover (16).
- 2 Install hammer guide yoke (5) on firing hammer (15) so groove in firing hammer lines up with holes in hammer guide yoke.

#### NOTE

Apply GAA to holes in hammer guide yoke before installing bearing balls.

- 3 Install spring (13) and sleeve bushing (12) on hammer guide yoke (5) and install three bearing balls (14) into hammer guide yoke holes between coils of spring. Slide sleeve bushing against spring until spring is fully compressed against the access cover (16).
- 4 Pull firing hammer (15) from hammer guide yoke (5) until sleeve bushing (12) locks in place.
- 5 Set yoke and hammer group on socket so firing hammer (15) hangs freely.
- 6 Assemble two grooved pins (8) and two retaining rings (7) in case (9), if disassembled.
- 7 Install two springs (11 and 10) over hammer guide yoke (5).
- 8 Install assembled case (9) over two springs (11 and 10).
- 9 Install follower (2) over assembled case (9) aligning pins with cutouts of follower.
- 10 Using M34 fuze setter, compress two springs (11 and 10) and follower (2) over hammer guide yoke (5) until manual control lever (4) can be inserted into hammer guide yoke.
- 11 Install grooved pin (3) in manual control lever (4) and hammer guide yoke (5).
- 12 Depress firing hammer (15) against solid flat surface to seat firing mechanism (1).







## 5-5 FIRING BLOCK ASSEMBLY AND FOLLOWER ASSEMBLY

This task covers: a. Disassembly b. Assembly

### INITIAL SETUP

Tools

Artillery and turret mechanic's tool kit  
(SC 5180-95-CL-A12)

Spanner wrench (item 17, Appx H)

Materials/Parts

- Spring pin (item 6.1, Appx G)

Spring pin (item 5, Appx G)

Equipment Condition

Firing block assembly removed (TM 9-2350-311-10)

### a. Disassembly

#### CAUTION

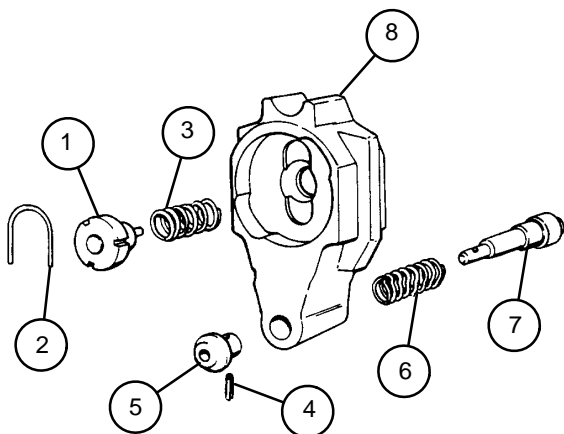
Firing pin is under pressure and will spring out when removed. Hold firing pin during disassembly to prevent loss of parts.

- 1 Depress firing pin (1) and remove.
- 2 Remove lock pin (2) and spring (3).
- 3 Remove spring pin (4) and discard.
- 4 Remove knob (5), spring (6) and follower assembly (7) from firing block (8).

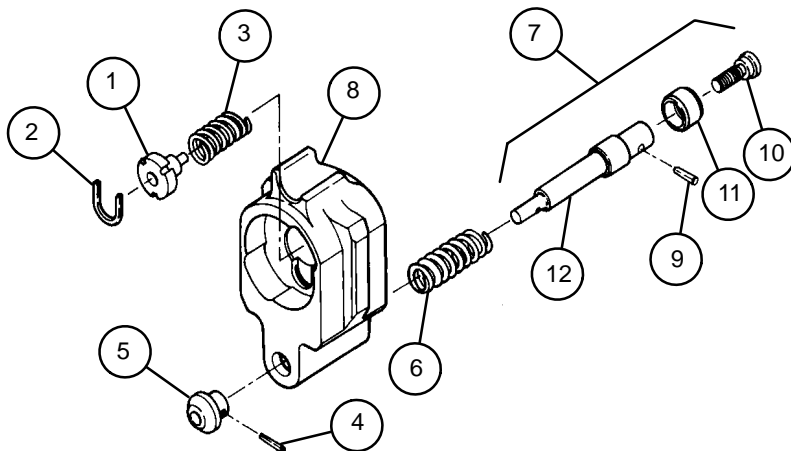
#### NOTE

Step 5 pertains to the M284 cannon only.

- 5 Remove spring pin (9), shoulder screw (10), and shaft roller (11) from follower shaft (12). Discard spring pin.



M185 CANNON CONFIGURATION



M284 CANNON CONFIGURATION

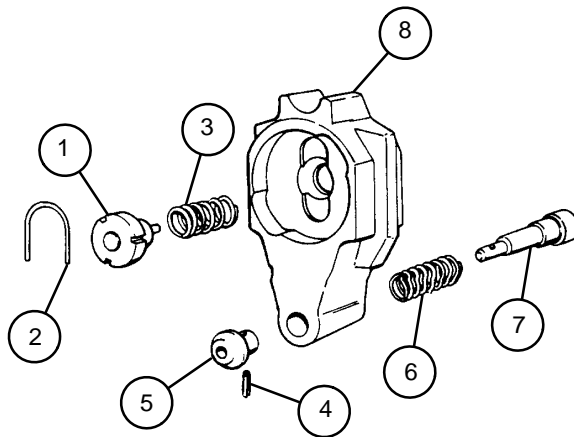
5-5 FIRING BLOCK ASSEMBLY AND FOLLOWER ASSEMBLY — CONTINUED

b. Assembly

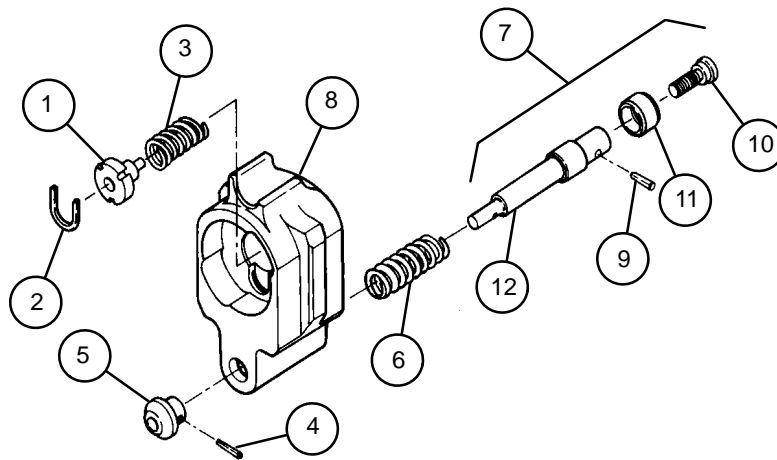
**NOTE**

Step 1 pertains to the M284 cannon only.

- 1 Install shaft roller (11) and shoulder screw (10) on follower shaft (12). Install new spring pin (9) into follower shaft.
- 2 Install follower assembly (7), spring (6), and knob (5) in firing block (8).
- 3 Install new spring pin (4).
- 4 Install spring (3) and firing pin (1).
- 5 Install lock pin (2) over firing pin (1).



M185 CANNON CONFIGURATION



M284 CANNON CONFIGURATION

## 5-6 ADJUSTER LEAF SPRING

- This task covers:
- |                 |                |
|-----------------|----------------|
| a. Removal      | b. Disassembly |
| c. Inspection   | d. Assembly    |
| e. Installation | f. Adjustment  |

### INITIAL SETUP

#### Tools

- Artillery and turret mechanic's tool kit (SC 5180-95-CL-A12)
- Pipe wrench (item 15, Appx H)
- Spacer (Figure E-3, Appx E)
- Spanner wrench (item 17, Appx H)

#### Materials/Parts

- Cotter pin (item 41, Appx G)

- GAA (item 17, Appx D)
- Masking tape (item 37, Appx D)
- Straight headless pin (item 4, Appx G)

#### Equipment Condition

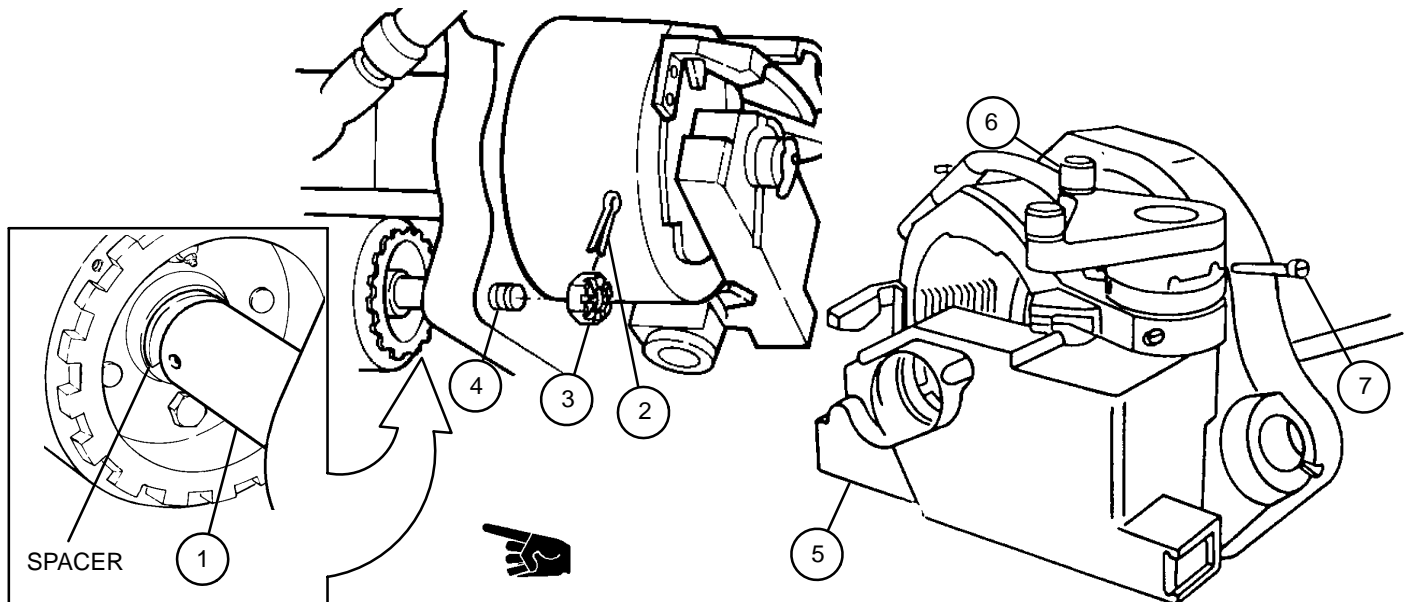
- Breech mechanism disassembled and breechblock assembly removed (TM 9-2350-311-10)

### a. Removal

#### WARNING

Cannon tube may slide out of battery and harm personnel if not placed at zero elevation.

- 1 Place cannon tube at zero elevation. If weapon is to be left unattended, secure cannon tube to prevent elevation.
- 2 Secure shaft collar (1) with spacer, remove cotter pin (2) and slotted nut (3) from recuperator piston shouldered shaft (4) and push cannon assembly out of battery until breech mechanism leaf spring adjuster clears end of rammer. Discard cotter pin.
- 3 Close breechblock carrier assembly (5) and rotate operating crank (6) clockwise as far as it will go. Remove headless shoulder pin (7).



## 5-6 ADJUSTER LEAF SPRING — CONTINUED

### a. Removal — Continued

- 4 Support adjuster (8) and leaf spring pack (9) with your hand. Unscrew and remove setscrew (10).
- 5 Remove adjuster (8) and leaf spring pack (9) from operating crank (6) and detent plunger (11) and adjuster spring (12) will fall out.

### b. Disassembly

Use a punch and hammer to drive out straight headless pin (13). Remove leaf spring pack (9) from adjuster (8). Do not remove expansion plug (14) from adjuster unless damaged. If damaged, punch expansion plug out of adjuster and replace. Discard straight headless pin.

### c. Inspection

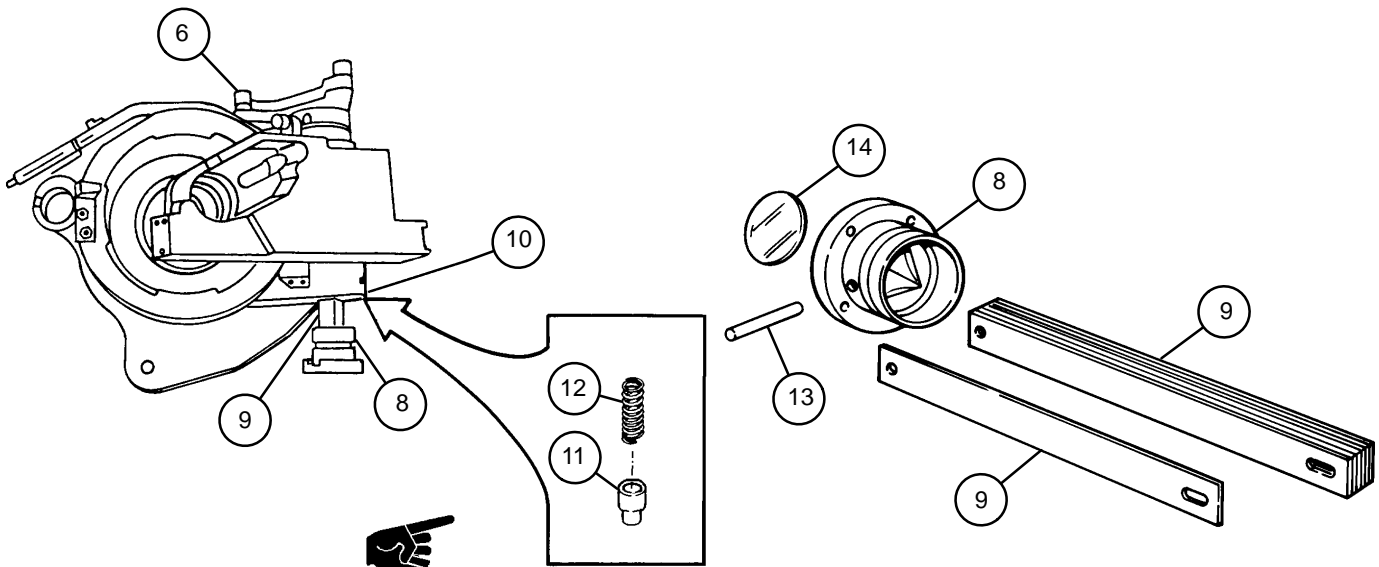
- 1 Inspect leaf spring pack (9) for broken or damaged springs. Replace if broken or damaged.
- 2 Inspect adjuster spring (12). Replace if distorted.

### d. Assembly

#### NOTE

When installing springs, always install as many springs as necessary to fill adjuster completely. Leaf spring packs will vary from 48 to 50 springs.

- 1 Coat each spring in leaf spring pack (9) with a light coat of grease before installing in adjuster (8). Secure springs to prevent separation by putting masking tape around leaf spring pack near bottom end. Insert leaf spring pack in adjuster and install new straight headless pin (13). Remove masking tape.
- 2 Install expansion plug (14), if removed, and stake in place.



### e. Installation

- 1 Position adjuster spring (12) and detent plunger (11) in operating crank (6).
- 2 Insert leaf spring pack (9) and adjuster (8) into operating crank (6) until adjuster is seated.
- 3 Install setscrew (10) and headless shoulder pin (7).
- 4 Return cannon assembly to battery. Secure shaft collar (1) with spacer, install and tighten slotted nut (3). Install new cotter pin (2) on recuperator piston shouldered shaft (4). Remove spacer.

### f. Adjustment

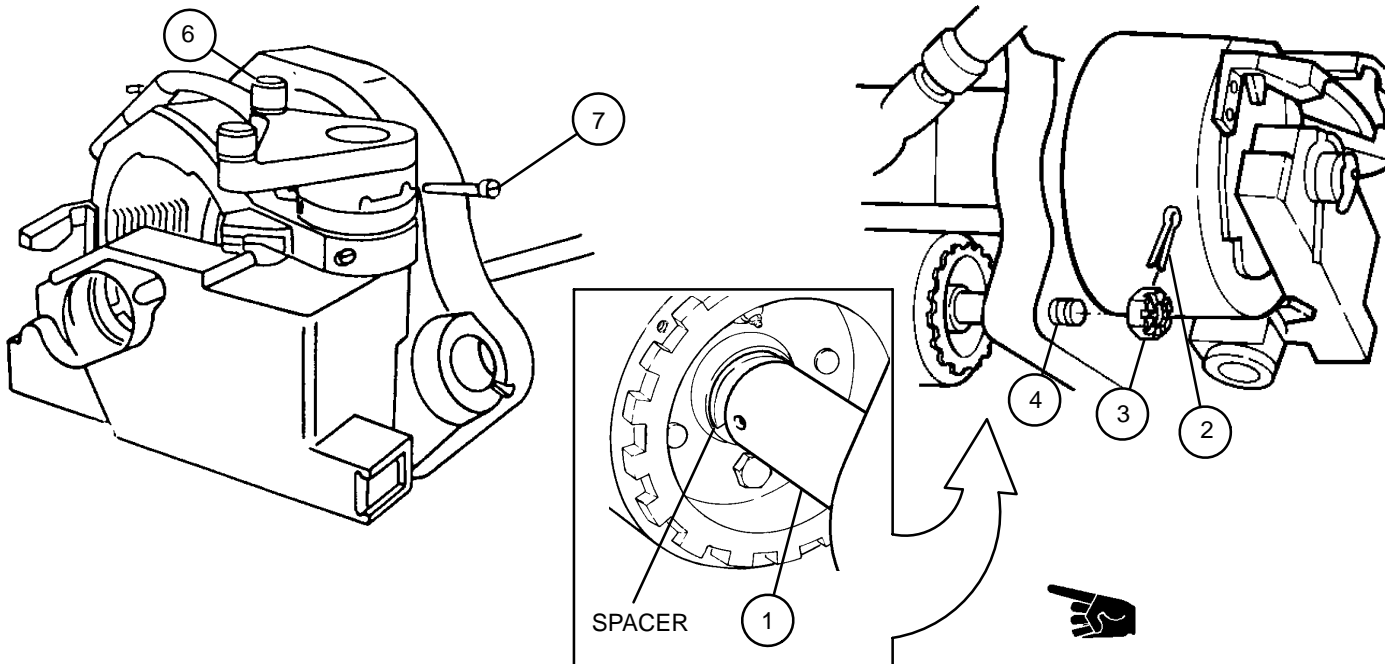
#### CAUTION

The notches in the adjuster provide graduations of adjustment. Do not apply more pre-load tension than is necessary to close the breechblock securely at the loading elevation (less than 300 mils). Use of final notch setting reduces the life of the leaf springs and should be used only if necessary (if breech does not close at loading elevation).

#### NOTE

- There are two types of adjusters. Some have holes for a spanner wrench. Others have lugs for an adjustable wrench.
- Adjuster may have only two graduations.

Depress detent plunger (11) and apply pre-load tension on breech mechanism closing springs by turning adjuster (8) clockwise.





**NOTE**

- It is not necessary to remove the plunger assembly from the cannon assembly if only the spindle assembly has to be removed for inspection or replacement.
- Perform steps 4 and 5 for the M185 cannon assembly.

4 Move firing group block (4) to extreme right hand position.

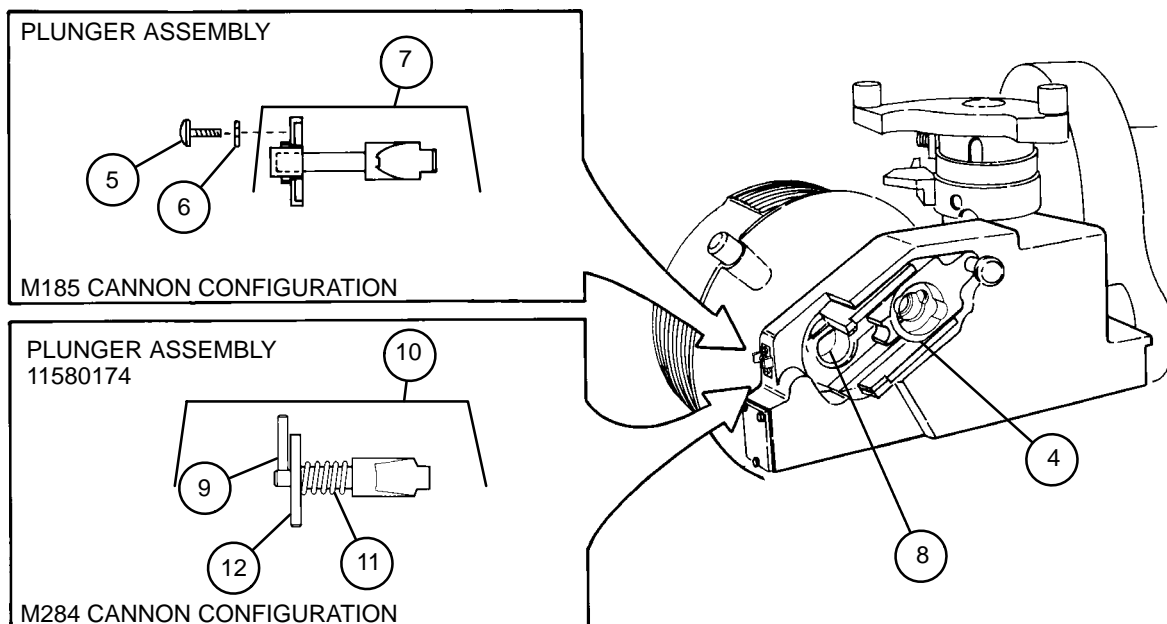
5 Remove two cap screws (5), two lockwashers (6), and plunger assembly (7) until it clears nut (8).

**NOTE**

- When plunger assembly 11580174 is lifted out and locked in place, the tip of the plunger will provide some support in holding the housing and firing group block in place while the spindle assembly is removed.
- The M284 cannon assembly has two configurations for the plunger assembly.
- Perform steps 6 and 7 for M284 cannon assembly containing plunger assembly 11580174.
- If plunger assembly cannot be pulled out easily, a screwdriver or pry tool can be inserted between plunger tip and nut. Applying leverage will free plunger assembly.

6 Grasp spring pin (9) located on top of plunger assembly (10). Pull outward against helical compression spring (11) until slot in plunger assembly lines up with cam plate (12).

7 Rotate plunger assembly (10) to lock with cam plate (12). Plunger assembly is now held in place and disengaged from nut (8).



## 5-7 SPINDLE ASSEMBLY — CONTINUED

### a. Removal — Continued

**NOTE**

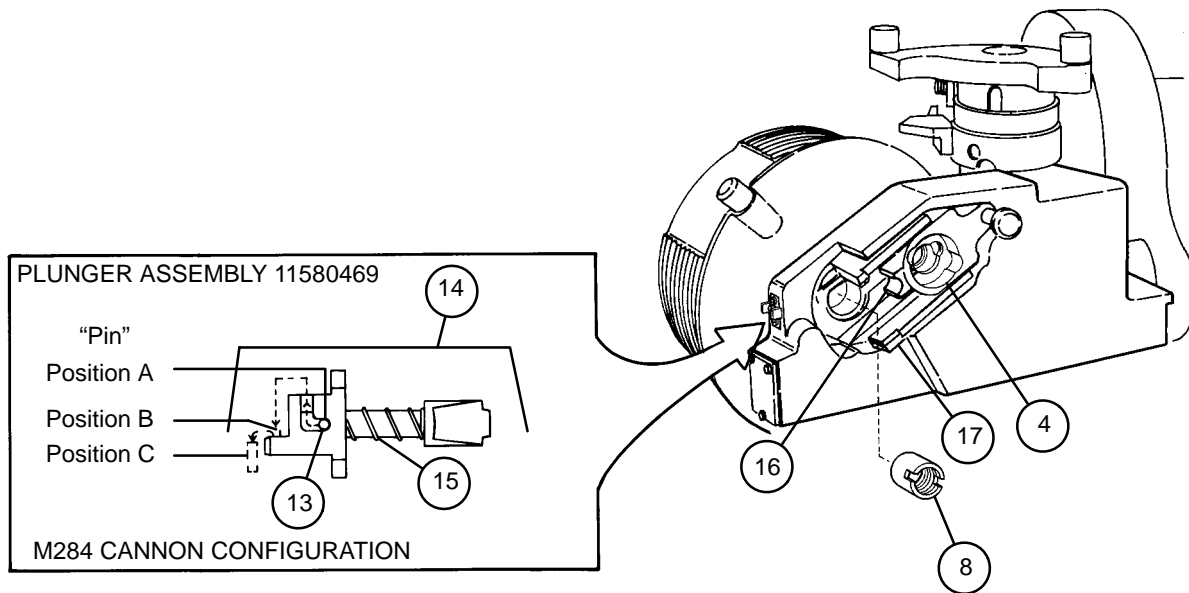
- Perform step 8 for M284 cannon assembly containing plunger assembly 11580469.
- When the plunger assembly is pulled out and locked in position B, the nut and spindle assembly can be removed without the housing and firing group block.
- the plunger assembly cannot be pulled out easily, a screwdriver or pry tool can be inserted between plunger tip and nut. Applying leverage will free plunger assembly.

- 8 Move pin (13) located on top of plunger assembly (14), against helical compression spring (15) from position A to position B.

**NOTE**

Cartridge extractor is located inside firing group block.

- 9 Partially withdraw nut (8) by moving cartridge extractor (16) away from nut. Support firing group block (4) and housing (17). Using spanner wrench, remove nut.





- 10 Remove spindle assembly (18) from breechblock (1). Push on spindle (19) as necessary.
- 11 Remove the following from spindle (19): washer bearing (20), rear retaining ring (21), inner retaining ring (22), obturator pad (23), and front retaining ring (24).

**CAUTION**

Do not apply oil or cleaning solvent to obturator pad to prevent damage to obturator pad.

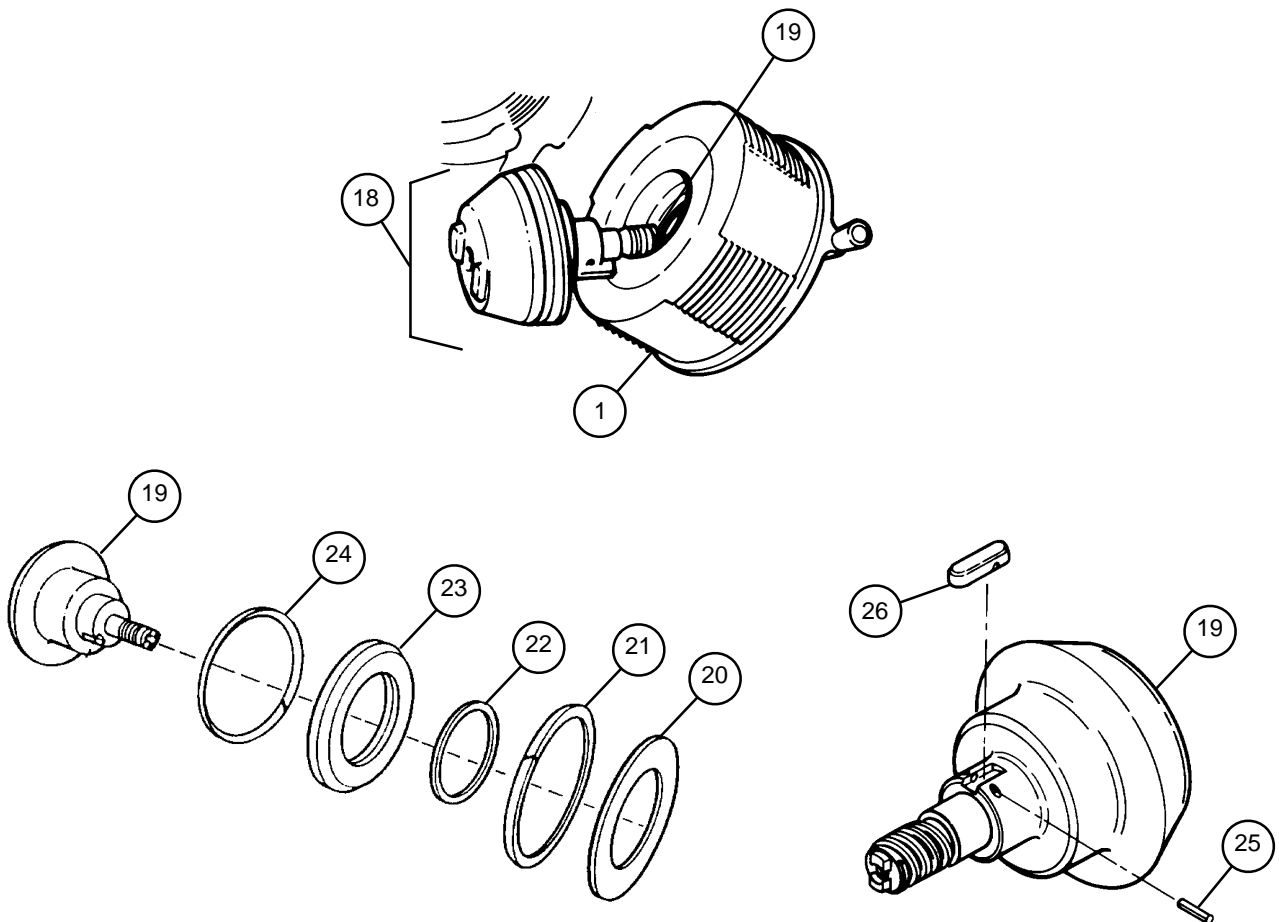
- 12 Clean obturator pad (23) with soap and water. Dry with clean rags.

**b. Disassembly**

Remove spring pin (25) and machine key (26) from spindle (19) shaft. Discard spring pin.

**c. Assembly**

Install machine key (26) in spindle (19) shaft and secure with new spring pin (25).



## 5-7 SPINDLE ASSEMBLY — CONTINUED

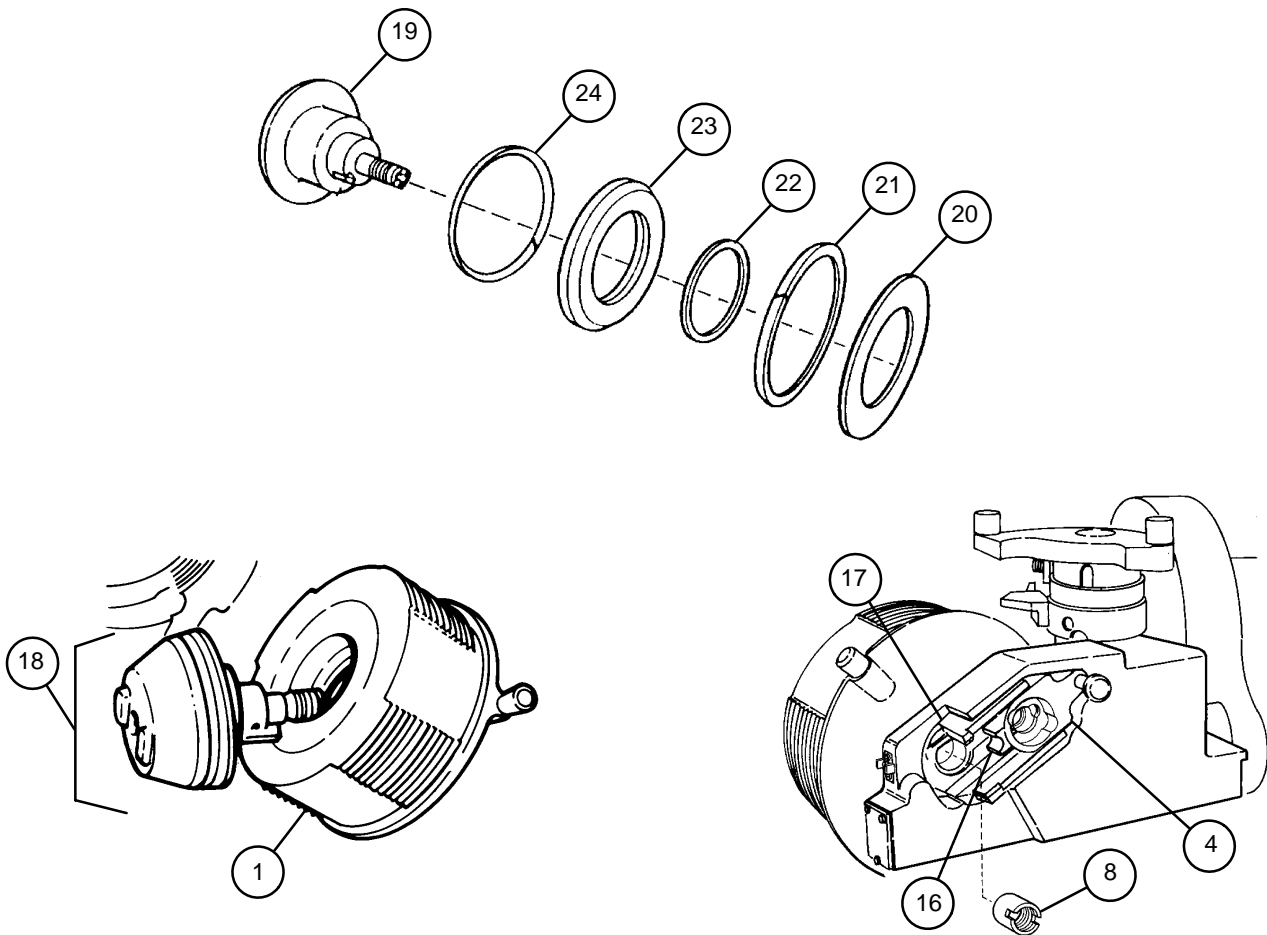
### d. Installation

- 1 Install the following on spindle (19): front retaining ring (24), obturator pad (23), inner retaining ring (22), rear retaining ring (21), and washer bearing (20). Make sure that retaining rings (21 and 24) are aligned 180° apart as shown.
- 2 Install spindle assembly (18) in breechblock (1).
- 3 Support housing (17) and firing group block (4). Install nut (8) using spanner wrench.

#### NOTE

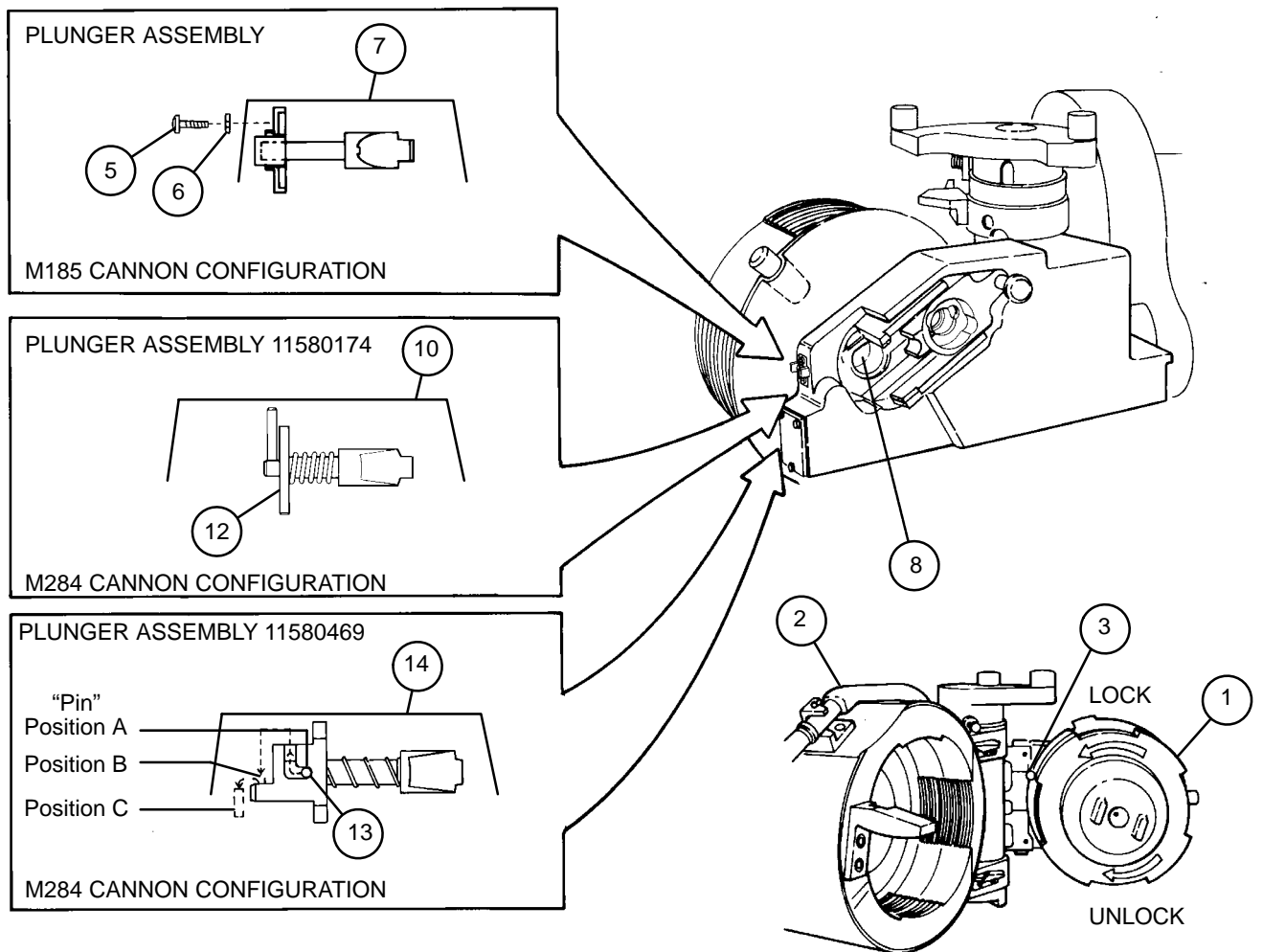
Cartridge extractor is located inside firing group block.

- 4 Position cartridge extractor (16) over nut (8).



**NOTE**

- Perform step 5 for the M185 cannon assembly.
  - Perform step 6 for the M284 cannon assembly with plunger assembly 11580174.
  - Perform step 7 for the M284 cannon assembly with plunger assembly 11580469.
- 5 Install plunger assembly (7) and secure with two new lockwashers (6) and two cap screws (5).
  - 6 Rotate plunger assembly (10) to release from cam plate (12). Be sure plunger assembly tip seats in narrow slot of nut (8).
  - 7 Rotate pin (13) from position B to position A to seat plunger assembly (14) tip in narrow slot of nut (8).
  - 8 Depress detent (3) with punch.
  - 9 Rotate breechblock (1) to UNLOCKED position.
  - 10 Close breechblock (1), using one mechanic to move operating handle (2) to CLOSED position and the other to support the breechblock.



---

## 5-8 BREECHBLOCK ASSEMBLY

---

This task covers: Inspection and Repair

---

### INITIAL SETUP

Tools

Artillery and turret mechanic's tool kit  
(SC 5180-95-CL-A12)

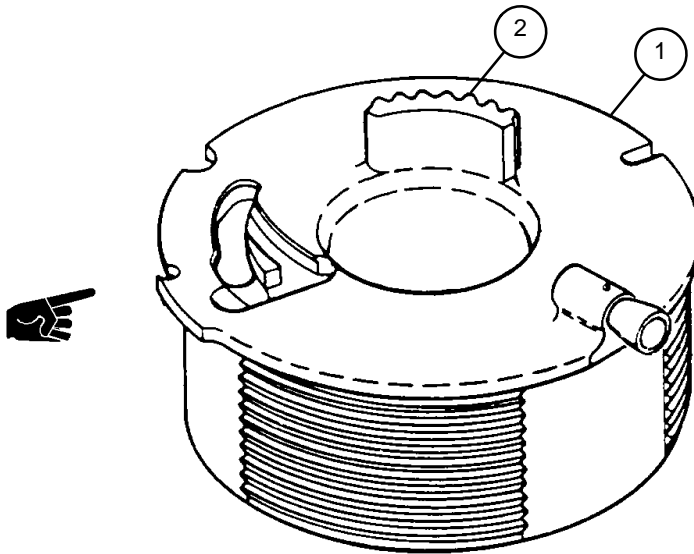
Equipment Condition

Spindle assembly removed (para 5-7)

---

### Inspection and Repair

- 1 Inspect breechblock (1) for damaged threads. Repair threads or replace breechblock.
- 2 Inspect gear segment (2) of breechblock (1). Replace breechblock if damaged or distorted.
- 3 Deleted.



#### NOTE

Breechblock is shown removed for clarity.

## 5-9 CARRIER ASSEMBLY

This task covers:

a. Removal	b. Disassembly
c. Inspection	d. Assembly
e. Installation	

### INITIAL SETUP

#### Tools

Artillery and turret mechanic's tool kit  
(CL 5180-95-A12, see SC 9999-01-SKO)

#### Materials/Parts

GAA (item 18, Appx D)  
Rope (item 26, Appx D)  
Lockwire (V) (item 31, Appx G) M109A5\*\*

#### Personnel Required

2

#### Equipment Condition

Breechblock assembly removed (TM 9-2350-311-10)

#### References

TM 9-2350-311-10

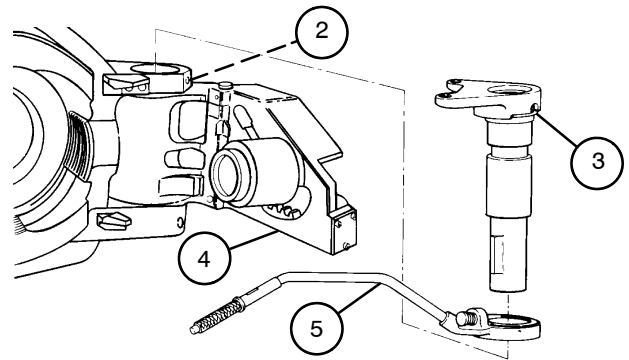
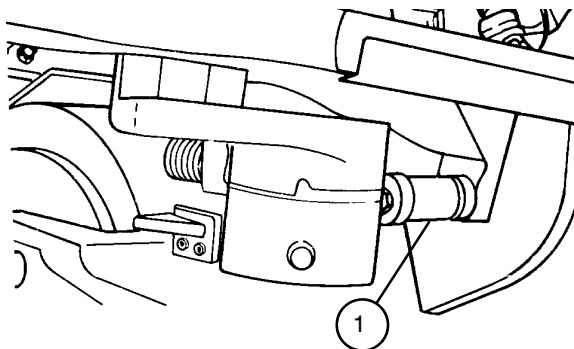
### a. Removal

- 1 Relieve tension on damper assembly (1) enough to raise and secure operating cam to cab roof with rope.
- 2 Remove adjuster leaf spring pack (para 5-6).
- 3 Unscrew breech ring upper lug detent (operating crank detent) (2) which engages annular groove of operating crank assembly (3).

### WARNING

Carrier assembly may fall and injure personnel if not supported.

- 4 While supporting carrier assembly (4), remove operating crank assembly (3) and operating handle (5).
- 5 Remove carrier assembly (4).



---

## 5-9 CARRIER ASSEMBLY — CONTINUED

---

### b. Disassembly

#### NOTE

The carrier assembly is marked next to the plunger with L for left and R for right.

- 1 Place carrier assembly (4) on a flat surface with right carrier detent plunger (6) down.
- 2 Remove spur gear (7) from carrier assembly (4).

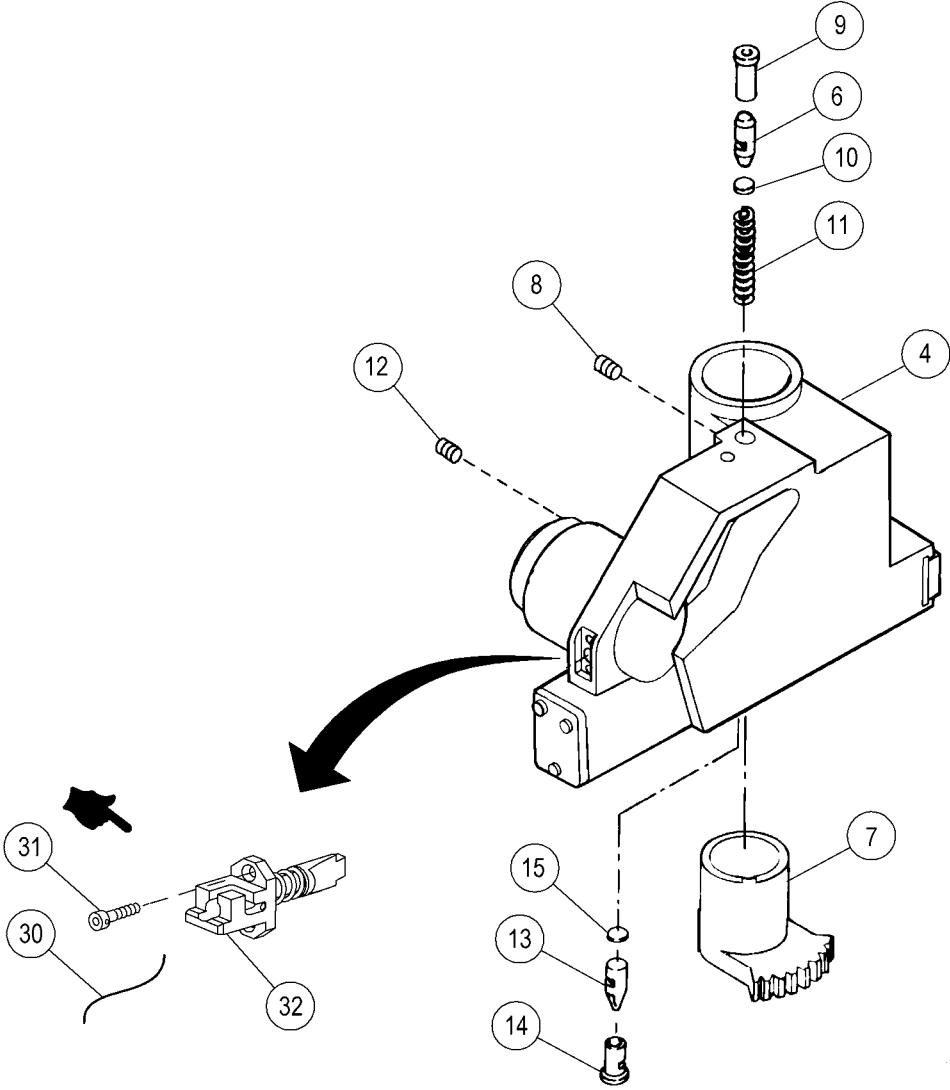
**WARNING**

Plunger assemblies hold compressed springs. Be careful during disassembly to avoid injury. Wear safety glasses to prevent possible eye injury.

- 3 Restrain right carrier detent plunger (6) while unscrewing right detent plunger (8). Release right carrier detent plunger gradually.
- 4 Remove right carrier detent plunger (6), right sleeve bushing (9), right disc (10), and helical compression spring (11) from carrier assembly (4).
- 5 Remove left detent plunger (12), left carrier detent plunger (13), left sleeve bushing (14), and left disc (15) from carrier assembly (4).
- 6 Deleted
- 7 Deleted
- 8 Deleted
- 9 Deleted
- 10 Deleted
- 11 Deleted
- 12 Remove lockwire (30), two cap screws (31), and plunger assembly (32). Discard lockwire.
- 13 Deleted

14 Deleted

15 Deleted



m02m109001c

---

## 5-9 CARRIER ASSEMBLY — CONTINUED

---

### b. Disassembly — Continued

- 16 Remove rack plate (38), gear rack (39), and stop (40) that restrains helical compression springs (41 and 42).

**WARNING**

Stop and detent plunger hold compressed springs. Use care during disassembly to avoid possible injury.

- 17 Remove spring pin (43) while restraining detent plunger (44) and helical compression spring (45). Discard spring pin.
- 18 Remove detent plunger (44) and helical compression spring (45).

### c. Inspection

**NOTE**

If any of the parts below are unserviceable, replace as required.

- 1 Inspect springs (41 and 42) for cracks and distortion.
- 2 Inspect operating crank assembly (3) for visible cracks.
- 3 Inspect carrier assembly (4) for cracks and distortion.
- 4 Place machinist's rule on cut-away end of detent plunger (44) and measure for excess wear. Replace if detent plunger measures less than 31/32 inch (24.6 mm) at any point.

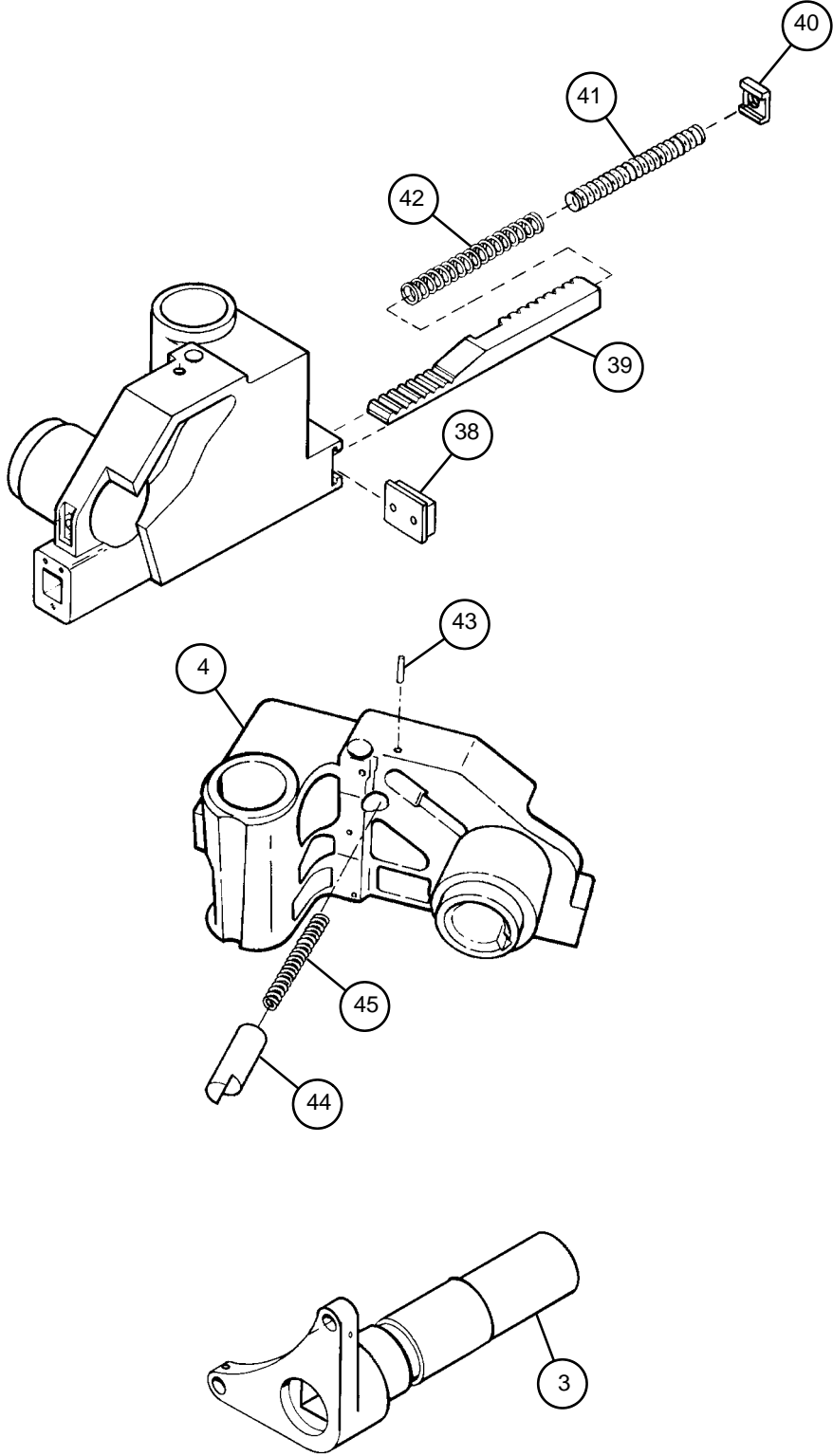
### d. Assembly

**WARNING**

Detent plunger and stop hold compressed springs. Use care during assembly to avoid possible injury.

- 1 Install helical compression spring (45), detent plunger (44), and new spring pin (43) in carrier assembly (4).
- 2 Lubricate helical compression springs (41 and 42) with GAA and install in gear rack (39). Install gear rack, stop (40), and rack plate (38).





---

## 5-9 CARRIER ASSEMBLY — CONTINUED

---

### d. Assembly - Continued

#### NOTE

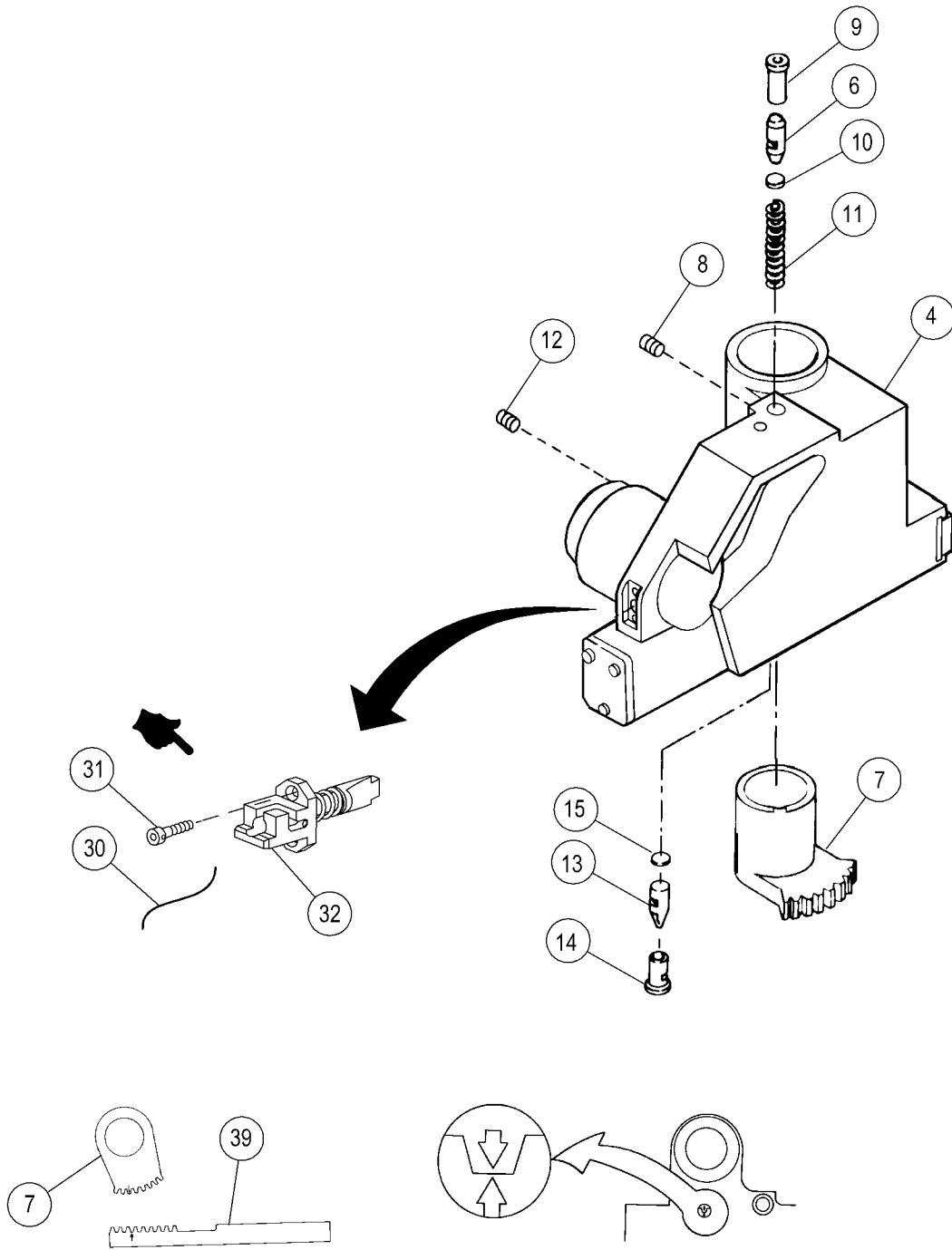
- Check for markings “L” and “R” to be sure plungers are installed in correct holes.

- 3 Deleted
- 4 Deleted
- 5 Deleted
- 6 Deleted
- 7 Deleted
- 8 Deleted
- 9 Deleted
- 10 Install plunger assembly (32) in carrier assembly (4) and secure with two cap screws (31) and new lockwire (30).
- 11 Install helical compression spring (11), right disc (10), right sleeve bushing (9), and right carrier detent plunger (6).
- 12 Install right detent plunger (8) to restrain right carrier detent plunger (6).
- 13 Install left disc (15), left sleeve bushing (14), and left carrier detent plunger (13).
- 14 Install left detent plunger (12) to restrain left carrier detent plunger (13).

#### NOTE

When installing spur gear into carrier assembly, the arrow of the spur gear must be aligned with arrow on gear rack. After arrows are aligned on spur gear, center arrows in inspection hole at bottom of carrier assembly before installing carrier assembly on breech ring. If arrows are not visible on spur gear and gear rack, scribe third tooth of spur gear and third root of gear rack as shown.

- 15 Align arrows on spur gear (7) and gear rack (39), then install spur gear (7) into carrier assembly (4).



m02m109002c

---

## 5-9 CARRIER ASSEMBLY — CONTINUED

---

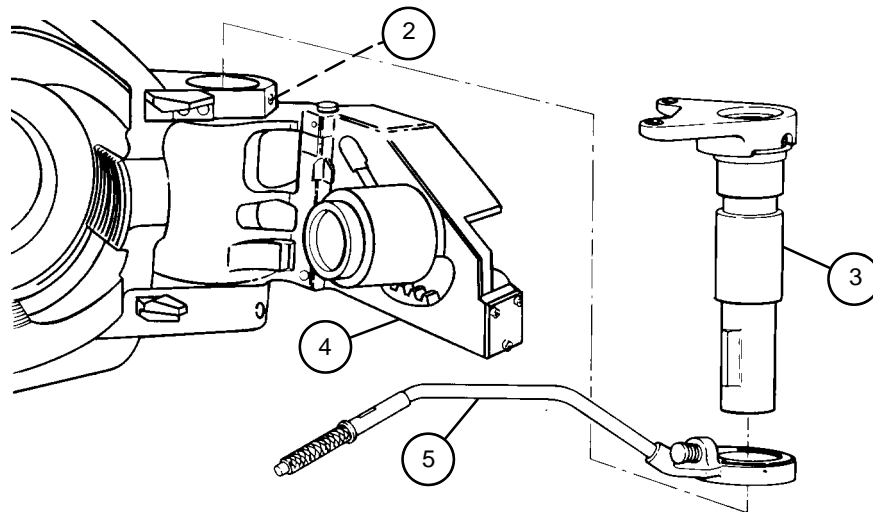
### e. Installation

- 1 Place carrier assembly (4) in breech ring and align operating crank holes.
- 2 Install operating handle (5) and operating crank assembly (3).

#### NOTE

The breech ring upper lug detent is stamped with a "U"; the adjuster detent (removed with adjuster leaf spring pack (para 5-6)) is stamped with an "L". These parts are not interchangeable.

- 3 Screw in breech ring upper lug detent (2), engaging annular groove of operating crank assembly (3).
- 4 Install adjuster leaf spring pack (para 5-6).
- 5 Install breechblock assembly (TM 9-2350-311-10).
- 6 Untie and release operating cam from cab roof. Perform adjustment procedures to operating cam (para 5-12).





## 5-10 TORQUE KEY — CONTINUED

### b. Inspection

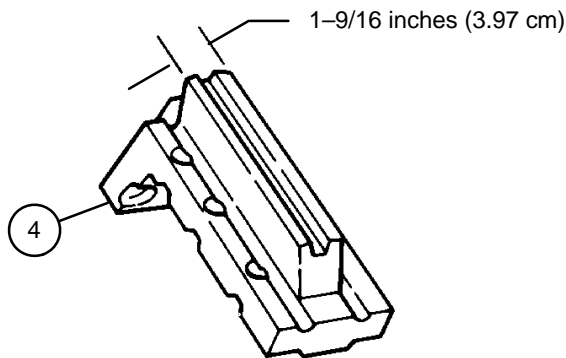
To inspect torque key (4), measure width of bottom surface in at least three different places. Replace torque key on M185 cannon assembly if width is less than  $31/32$  inch (24.6 mm) at any point along bottom of taper or if torque key on M284 cannon assembly is less than  $1-9/16$  inches (3.97 cm).

### c. Installation

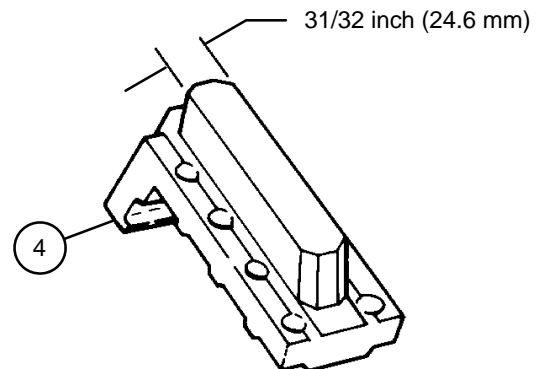
**CAUTION**

Do not hammer torque key into keyway(s), as damage to torque key may result. If torque key does not slide into place, rotate cannon tube slightly by placing a timber or crowbar through the muzzle brake.

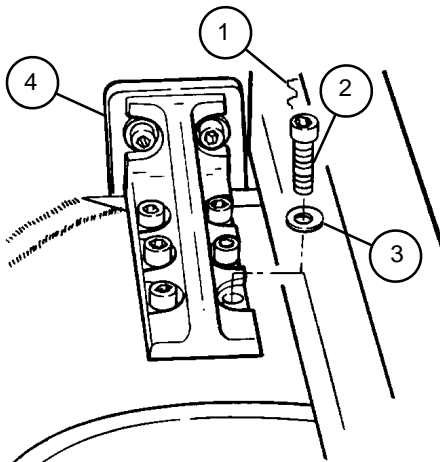
- 1 Lubricate surfaces of torque key (4) with grease (para 2-9).
- 2 Install torque key (4), eight or ten new lockwashers (3), and eight or ten cap screws (2).
- 3 Install new lockwire (1).
- 4 Check breech operating cam for proper adjustment (para 5-12).



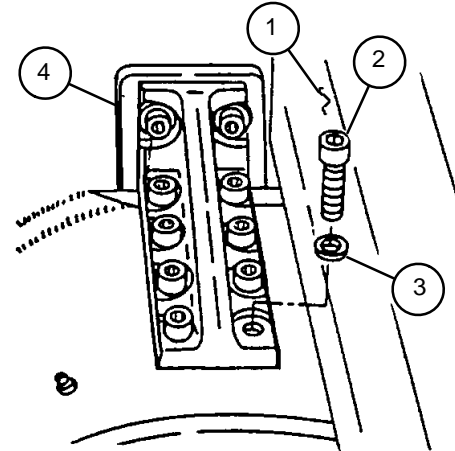
M182 MOUNT CONFIGURATION



M178 MOUNT CONFIGURATION



M182 MOUNT CONFIGURATION



M178 MOUNT CONFIGURATION

## 5-11 DAMPER ASSEMBLY

This task covers: a. Removal/Disassembly b. Assembly/Installation

### INITIAL SETUP

#### Tools

Artillery and turret mechanic's tool kit  
(SC 5180-95-CL-A12)

#### a. Removal/Disassembly

- 1 Remove cap screw (1), hex nut (2), and remaining parts of damper assembly (3).
- 2 Remove two seats (4), sleeve spacer (5), spring (6), and sleeve spacer (7).

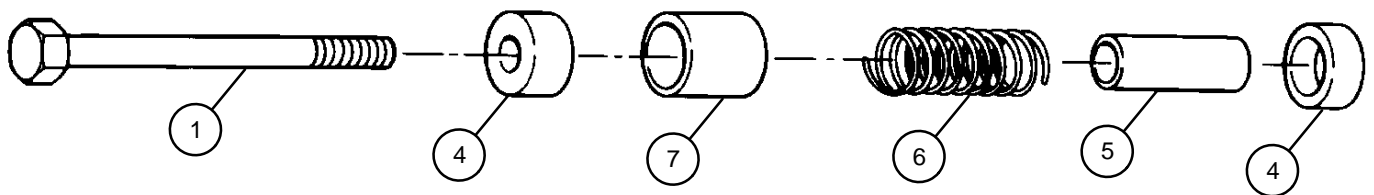
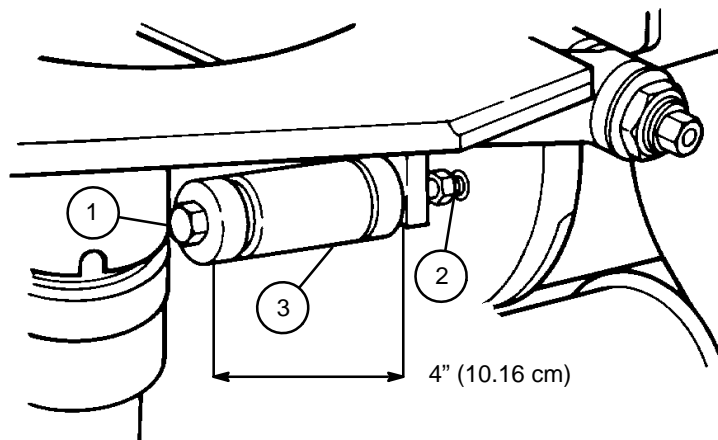
#### b. Assembly/Installation

- 1 Place seat (4), sleeve spacer (7), spring (6), sleeve spacer (5), and other seat (4) on cap screw (1).

#### NOTE

Breech must be in a closed position to obtain correct adjustment.

- 2 Secure assembled damper assembly (3) components in place with hex nut (2). Tighten cap screw (1) until seat to seat length of damper assembly is 4 inches (10.16 cm). Tighten hex nut.



## 5-12 OPERATING CAM

This task covers:    a. Preparation for Adjustment            b. Vertical Adjustment  
                               c. Horizontal Adjustment                                    d. Preparation for Service

### **INITIAL SETUP**

Tools

Artillery and turret mechanic's tool kit  
 (SC 5180-95-CL-A12)  
 Fabricated bracket (Figure E-2, Appx E)  
 5-ton wrecker  
 Spacer (Figure E-3, Appx E)

Personnel Required

2

Materials/Parts

Cotter pin (item 41, Appx G)

### a. Preparation for Adjustment

**WARNING**

- When working on mount and cannon breech components, with cannon pushed out of battery, block cannon breech with suitable blocking, or chain tube to hull to prevent accidental elevation of cannon assembly and injury to personnel or damage to equipment.
- Operators should be in both vehicles while cannon tube is being pushed out of battery. Brakes in both vehicles must be fully applied during this operation to prevent injury to personnel and avoid damage to vehicles.

**NOTE**

Set breechblock mechanism in closed position before beginning procedure.

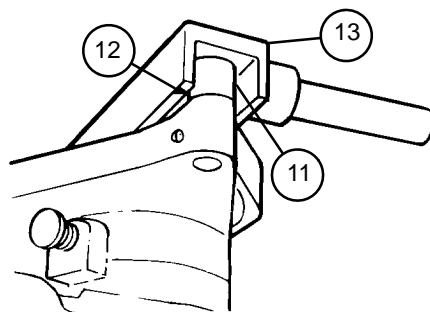
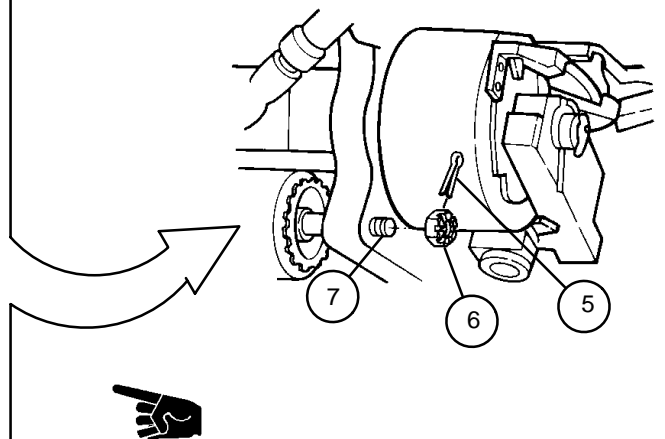
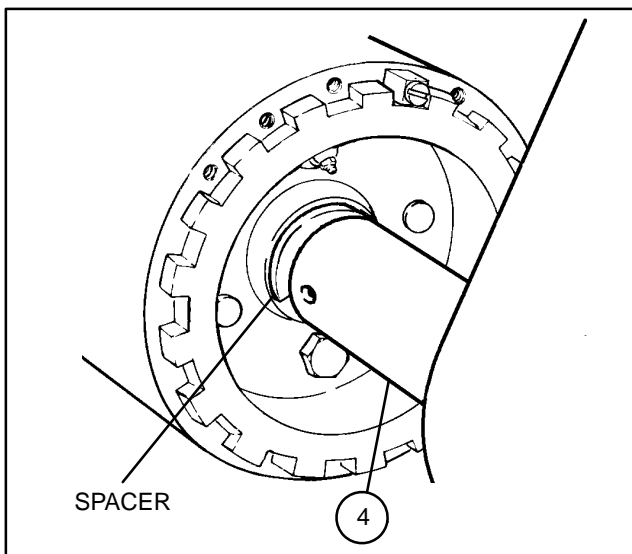
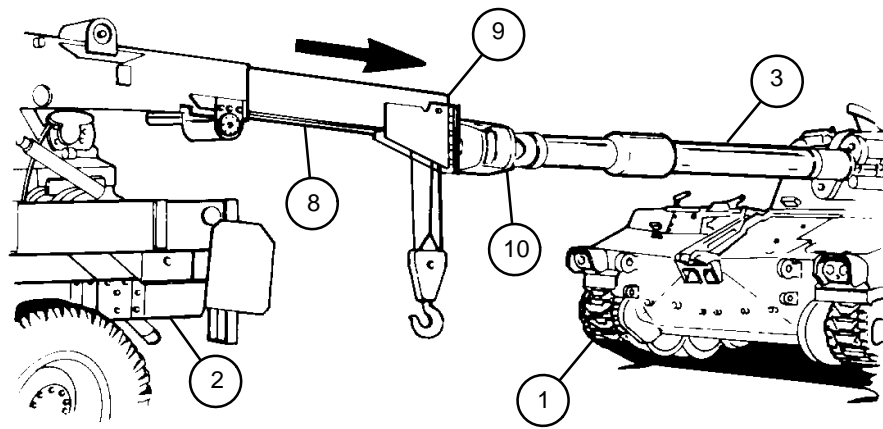
- 1 Position howitzer (1) and 5-ton wrecker (2) on level ground.
- 2 Set cannon tube (3) to zero elevation (TM 9-2350-311-10).

**NOTE**

Place spacer between shaft collar and recuperator housing.

- 3 Secure the shaft collar (4) with spacer, remove cotter pin (5) and slotted nut (6) from end of recuperator piston shouldered shaft (7). Discard cotter pin.
- 4 Position 5-ton wrecker (2) directly in front of howitzer (1). Aline wrecker boom (8) with cannon tube (3).
- 5 Install fabricated bracket (9) on wrecker boom (8).
- 6 Extend wrecker boom (8) to muzzle brake (10). Slowly, push cannon tube (3) out of battery. Push until roller (11) is positioned opposite arrow (12) on bottom of breech operating cam (13).

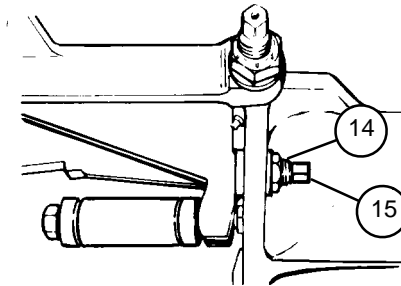
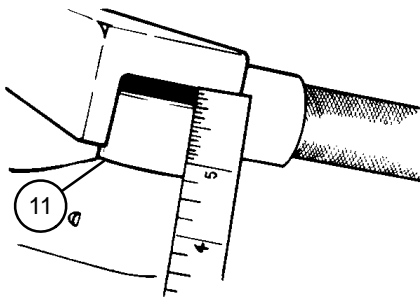




## 5-12 OPERATING CAM — CONTINUED

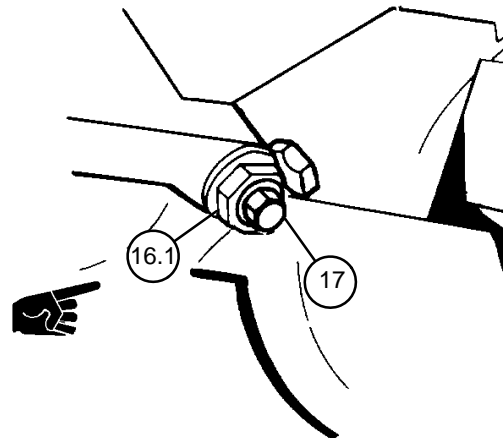
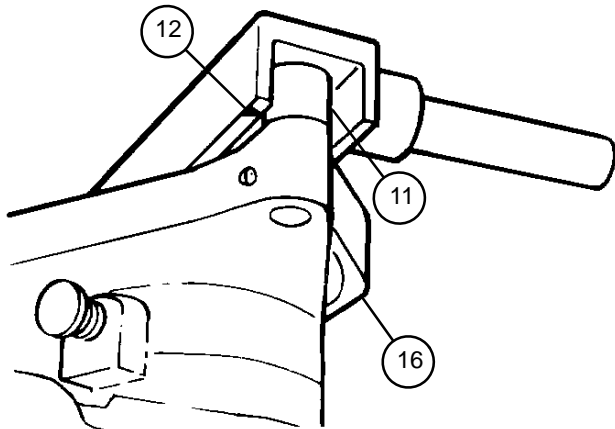
### b. Vertical Adjustment

- 1 Measure clearance of roller (11) from top of cam path. Clearance must be between 3/16 inch (4.8 mm) and 1/4 inch (6.35 mm). Refer to steps 2 and 3 to adjust.
- 2 Loosen self-locking nut (14).
- 3 Adjust cradle cam stop (15) with wrench. Turn counterclockwise to increase clearance, clockwise to decrease clearance. When adjusted, hold cradle cam stop steady with wrench and tighten self-locking nut (14).



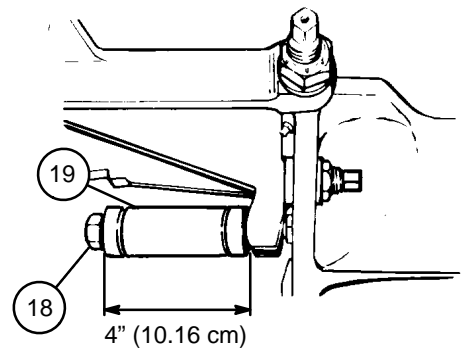
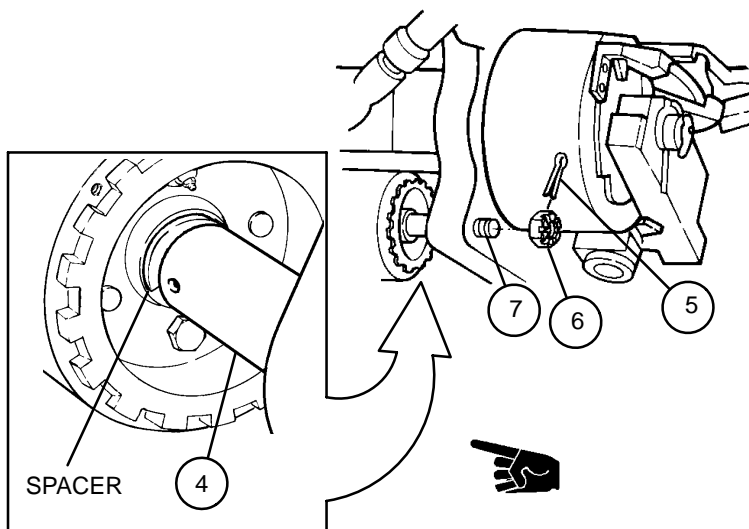
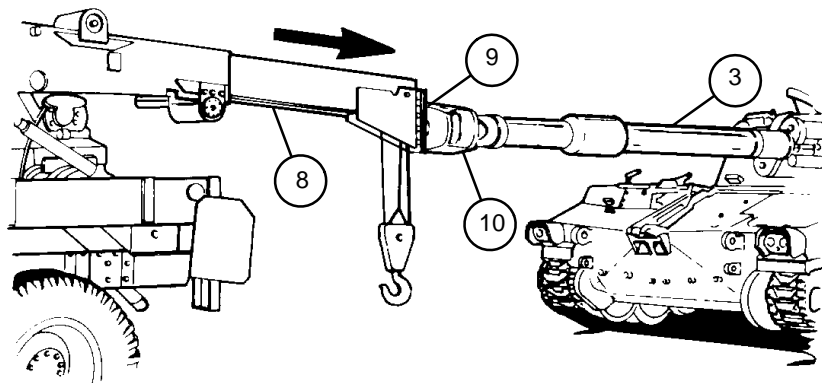
### c. Horizontal Adjustment

- 1 Rotate crank (16) counterclockwise as far as it will go.
- 2 Use thickness gage to measure clearance between roller (11) and cam path. Measure at arrow (12). Clearance should be at least 0.001 inch (0.025 mm), but not more than 0.002 inch (0.05 mm). Refer to steps 3 and 4 to adjust.
- 3 Loosen self-locking nut (16.1).
- 4 Adjust breech cam pin (17) with wrench. Turn counterclockwise to increase clearance, clockwise to decrease clearance. When adjusted, hold breech cam pin steady with wrench and tighten self-locking nut (16.1).



**d. Preparation for Service**

- 1 Lace cable through muzzle brake (10) and secure to wrecker boom (8).
- 2 Slowly retract wrecker boom (8) to pull cannon tube (3) back into battery.
- 3 Secure the shaft collar (4) with spacer, install slotted nut (6) and new cotter pin (5) on recuperator piston shouldered shaft (7). Remove spacer.
- 4 Remove fabricated bracket (9) and cable from wrecker boom (8).
- 5 Close the breech.
- 6 Adjust cap screw (18) to set damper assembly (19) to the correct length of 4 inches (10.16 cm).



## 5-13 DUST SHIELD AND VARIABLE RECOIL ACCESS COVER

- This task covers:
- |                          |                |
|--------------------------|----------------|
| a. Removal               | b. Disassembly |
| c. Inspection and Repair | d. Assembly    |
| e. Installation          |                |

### INITIAL SETUP

Tools

Artillery and turret mechanic's tool kit  
(SC 5180-95-CL-A12)

Materials/Parts

- Adhesive (item 1, Appx D)
- Gasket (item 111.1, Appx G)
- Gasket (item 112, Appx G)
- Gasket (item 121, Appx G)

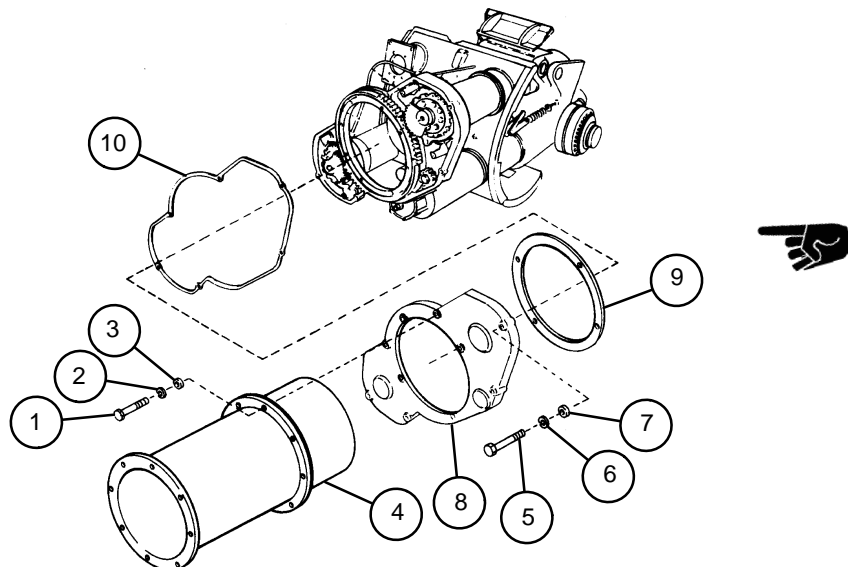
- Gasket (item 170, Appx G)
- Gaskets (2) (item 169, Appx G)
- Mechanical felt (item 122, Appx G)
- Mechanical felt (item 171, Appx G)
- Lockwashers (6) (item 80, Appx G)
- Self-locking nuts (8) (item 34, Appx G)

Equipment Condition

- Muzzle brake removed (TM 9-2350-311-10)
- Bore evacuator removed (TM 9-2350-311-10)

### a. Removal

- 1 Remove four machine bolts (1), four lockwashers (2), and four flat washers (3) from dust shield (4). Discard lockwashers.
- 2 Remove six machine bolts (5), six lockwashers (6), and six flat washers (7) from variable recoil access cover (8). Discard lockwashers.
- 3 Slide dust shield (4), variable recoil access cover (8), gasket (9), and gasket (10) toward front of cannon tube. Discard gaskets.



**b. Disassembly**

- 1 Remove eight self-locking nuts (11) and eight machine bolts (12) from dust shield (4). Discard self-locking nuts.

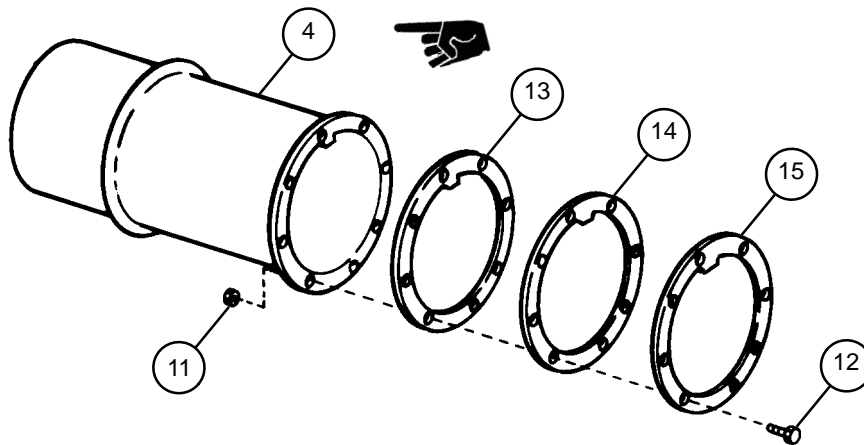
**NOTE**

Step 2 applies to M178 mount configuration. Step 3 applies to M182 mount configuration.

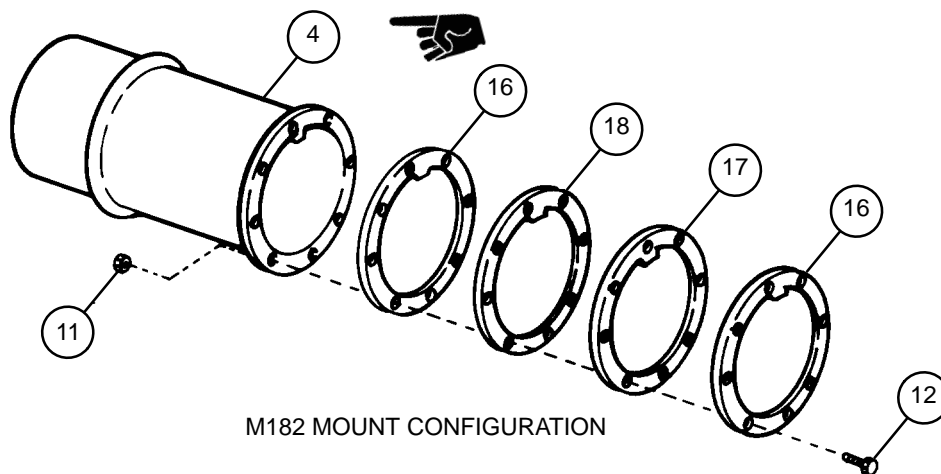
- 2 Separate dust shield (4), mechanical felt (13), gasket (14), and retainer (15). Discard mechanical felt and gasket.
- 3 Separate dust shield (4), two gaskets (16), gasket (17), and mechanical felt (18). Discard gaskets and mechanical felt.

**c. Inspection and Repair**

- 1 Inspect dust shield (4) for distortion. Repair or replace if damaged or distorted.
- 2 Inspect retainer (15). Replace if distorted or if tab is worn.



M178 MOUNT CONFIGURATION



M182 MOUNT CONFIGURATION

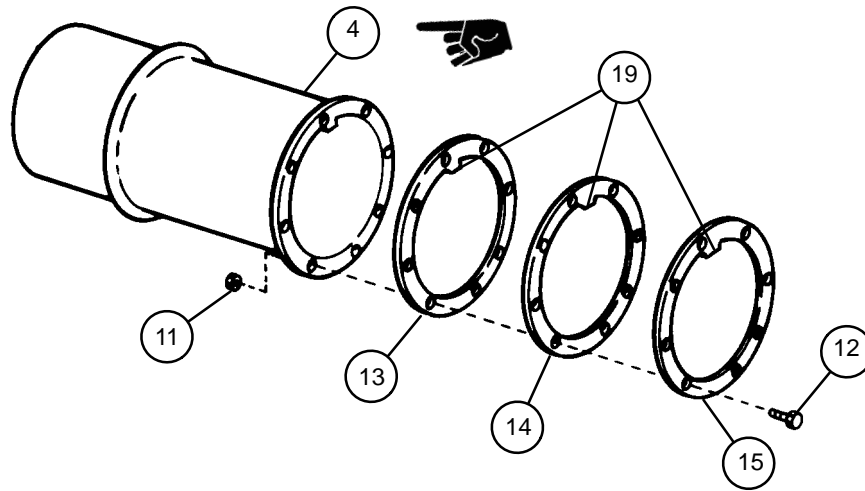
5-13 DUST SHIELD AND VARIABLE RECOIL ACCESS COVER — CONTINUED

d. Assembly

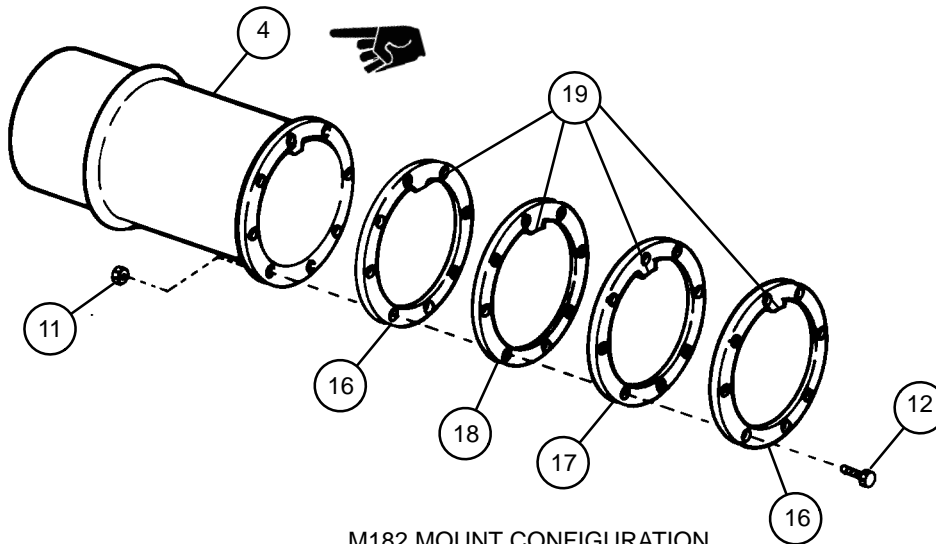
NOTE

- Step 1 applies to M178 mount configuration. Step 2 applies to M182 mount configuration.
- Be sure tabs (19) are alined to fit into keyway(s) at top of cannon tube.

- 1 Assemble retainer (15), new gasket (14), new mechanical felt (13) and dust shield (4).
- 2 Assemble new mechanical felt (18), new gasket (17), and two new gaskets (16) to dust shield (4).
- 3 Install eight machine bolts (12) and eight new self-locking nuts (11) into dust shield (4).



M178 MOUNT CONFIGURATION



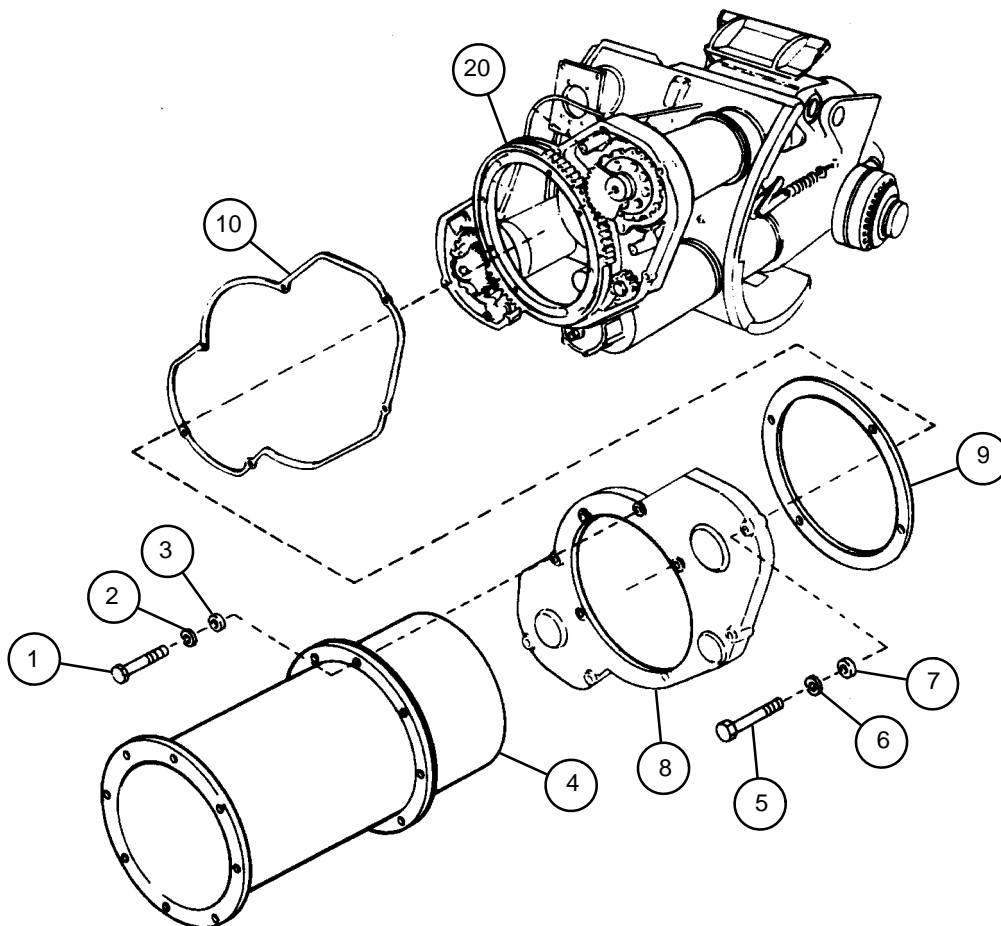
M182 MOUNT CONFIGURATION

## e. Installation

**WARNING**

Adhesives can burn easily, can give off harmful vapors, and are harmful to skin and clothing. To avoid injury or death, keep away from open fire and use in well-ventilated area. If adhesive gets on skin or clothing, wash immediately with soap and water.

- 1 Apply adhesive to new gasket (10) and install against variable recoil housing (20).
- 2 Apply adhesive to new gasket (9) and install against variable recoil access cover (8).
- 3 Slide dust shield (4) and variable recoil access cover (8) back against variable recoil housing (20).
- 4 Install six flat washers (7), six new lockwashers (6), and six machine bolts (5).
- 5 Install four flat washers (3), four new lockwashers (2), and four machine bolts (1).



## 5-14 M42 PERISCOPE COVER DOOR

This task covers: a. Removal b. Installation

### INITIAL SETUP

Tools

Artillery and turret mechanic's tool kit  
(SC 5180-95-CL-A12)

Lockwashers (6) (item 83, Appx G)

Spring pin (item 135, Appx G)

Materials/Parts

Lockwashers (4) (item 81, Appx G)

References

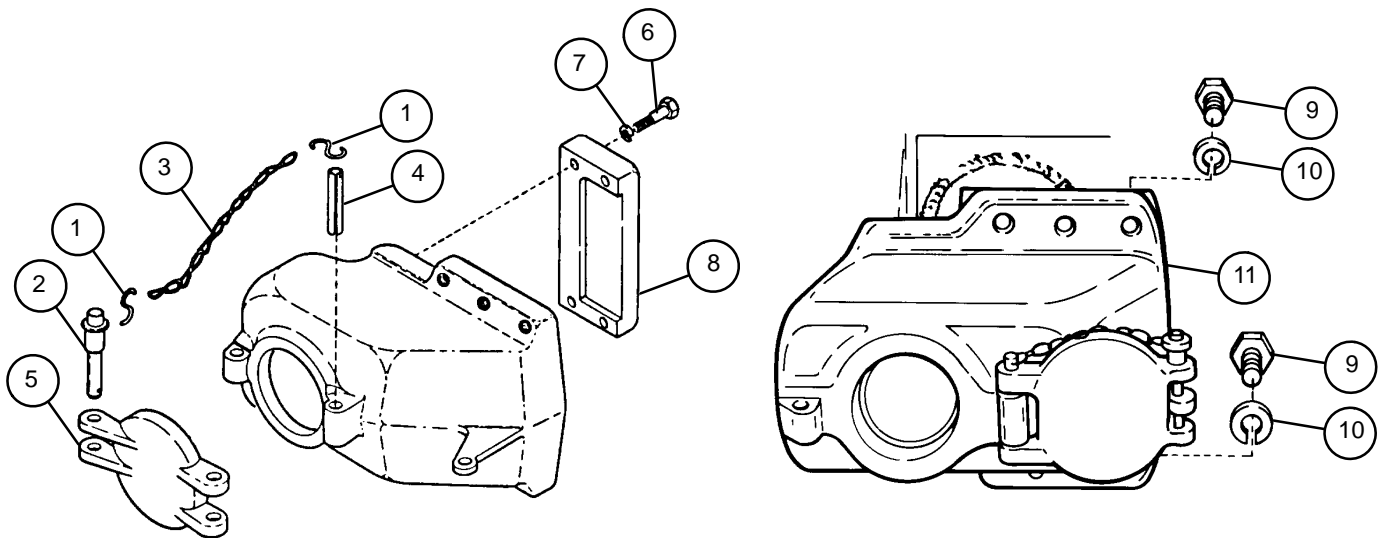
TM 750-116

#### a. Removal

- 1 Remove two "S" hooks (1), quick release pin (2), and chain (3).
- 2 Remove spring pin (4) and cover door (5). Discard spring pin.
- 3 Remove four cap screws (6), four lockwashers (7), and spacer plate (8). Discard lockwashers.
- 4 Remove six cap screws (9), six lockwashers (10), and cover (11). Discard lockwashers.

#### b. Installation

- 1 Install cover (11) with six new lockwashers (10) and six cap screws (9).
- 2 Install spacer plate (8) with four new lockwashers (7), and four cap screws (6).
- 3 Install cover door (5) with new spring pin (4).
- 4 Install two "S" hooks (1), chain (3), and quick release pin (2).









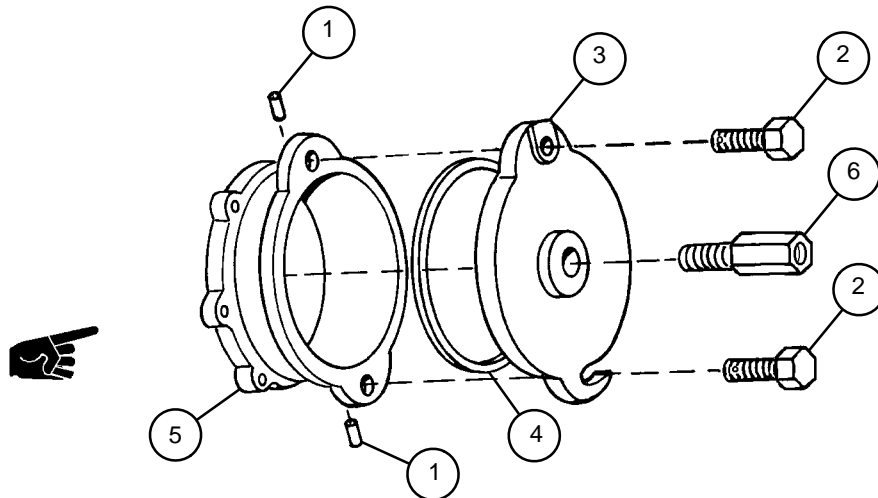
**b. Assembly**

- 1 Install safety relief valve (6).

**WARNING**

Adhesives can burn easily, can give off harmful vapors, and are harmful to skin and clothing. To avoid injury or death, keep away from open fire and use in well-ventilated area. If adhesive gets on skin or clothing, wash immediately with soap and water.

- 2 Apply adhesive to new gasket (4) and place in groove of cover (3). Allow adhesive to dry.
- 3 Install cover (3) and two cap screws (2) on cover adapter (5).
- 4 Install two new spring pins (1).





## 5-17 BUFFER ASSEMBLY

This task covers: Inspection

### INITIAL SETUP

#### Tools

Artillery and turret mechanic's tool kit  
(SC 5180-95-CL-A12)  
Fabricated bracket (Figure E-2, Appx E)  
5-ton wrecker  
Spacer (Figure E-3, Appx E)

#### Materials/Parts

Cotter pin (item 41, Appx G)

#### Personnel Required

2

### Inspection

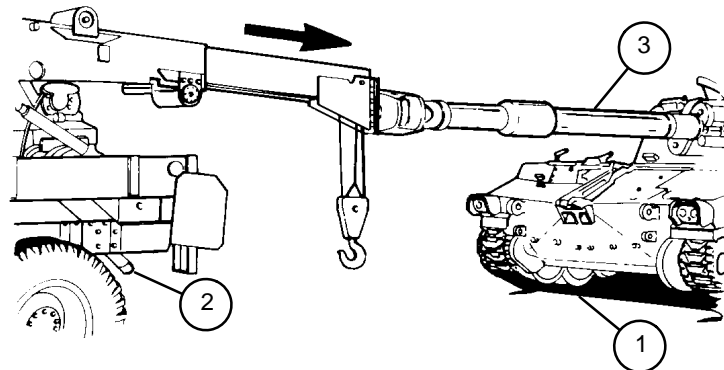
#### WARNING

- When working on mount and cannon breech components, with cannon assembly pushed out of battery, block cannon breech with suitable blocking, or chain tube to hull to prevent accidental elevation of cannon assembly and injury to personnel or damage to equipment.
- Operators should be in both vehicles while cannon tube is being pushed out of battery. Brakes in both vehicles must be fully applied during this operation to prevent injury to personnel and avoid damage to vehicles.

#### NOTE

Set breechblock mechanism in closed position before beginning procedure.

- 1 Position howitzer (1) and 5-ton wrecker (2) on level ground.
- 2 Set cannon tube (3) to zero elevation (TM 9-2350-311-10).



---

## 5-17 BUFFER ASSEMBLY — CONTINUED

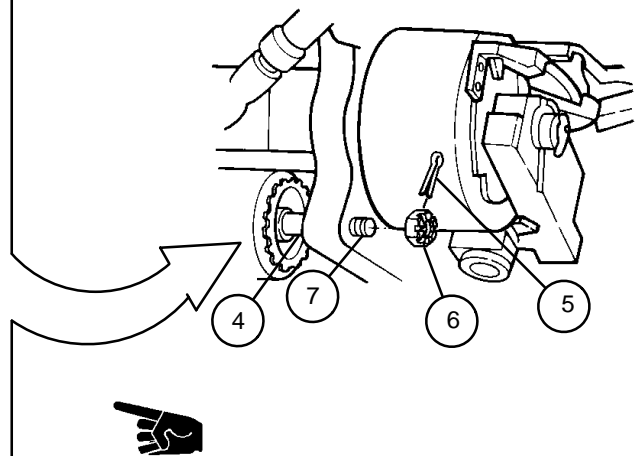
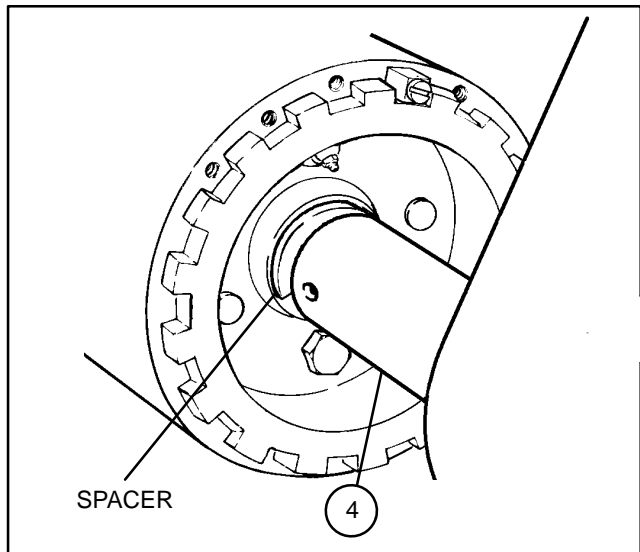
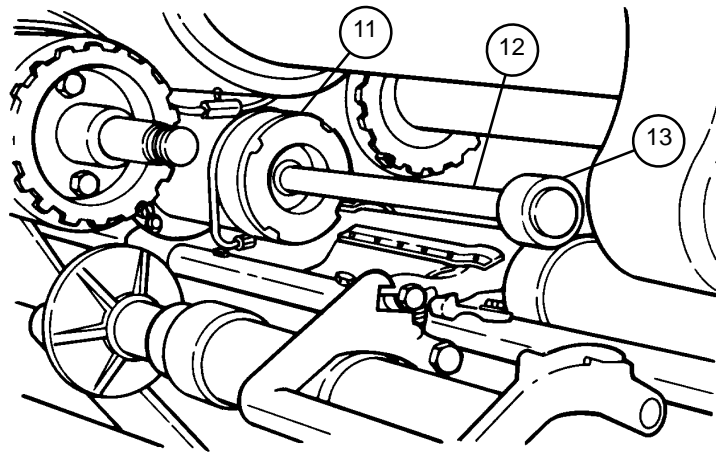
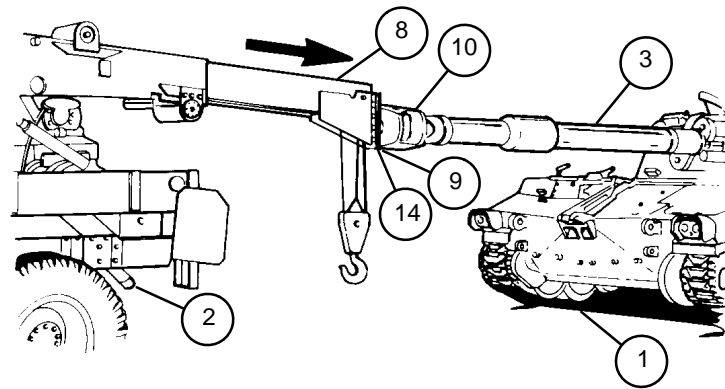
---

### Inspection — Continued

#### NOTE

Place spacer between shaft collar and recuperator housing.

- 3 Secure shaft collar (4) with spacer, remove cotter pin (5) and slotted nut (6) from end of recuperator shouldered shaft (7). Discard cotter pin.
- 4 Position 5-ton wrecker (2) directly in front of howitzer (1). Aline wrecker boom (8) with cannon tube (3).
- 5 Install fabricated bracket (9) on wrecker boom (8).
- 6 Extend wrecker boom (8) to muzzle brake (10). Slowly push cannon tube (3) out of battery.
- 7 Inspect counter recoil buffer (11) for leaks around seals, tube connectors, and buffer piston rod (12). Notify support maintenance if defects are found.
- 8 Inspect buffer piston rod (12) for the following:
  - (a) Full spring extension (approximately 13 inches (33.02 cm)). Notify support maintenance if spring extends beyond full extension.
  - (b) Paint or foreign matter on buffer piston rod (12) end. Remove all paint and foreign matter found.
  - (c) Defective buffer assembly. If buffer piston rod (12) can be pushed in housing easily, then buffer assembly is defective. Notify support maintenance.
- 9 Inspect buffer piston rod bumper assembly (13) for gouges, mushrooming, and cracks. Notify support maintenance if defects are found.
- 10 Lace cable (14) through muzzle brake (10) and secure to wrecker boom (8).
- 11 Retract wrecker boom (8) to pull cannon tube (3) back into battery.
- 12 Secure the shaft collar (4) with spacer, install slotted nut (6) and new cotter pin (5) on recuperator shouldered shaft (7). Remove spacer.
- 13 Remove cable (14) and fabricated bracket (9) from cannon tube (3) and wrecker boom (8).



## 5-18 ACCESS COVER (M182 MOUNT)

This task covers: a. Removal b. Installation

### INITIAL SETUP

Applicable Configuration

M109A5 howitzer

Tools

Artillery and turret mechanic's tool kit  
(SC 5180-95-CL-A12)

Materials/Parts

Gasket (item 172, Appx G)  
Lockwashers (2) (item 96, Appx G)  
Self-locking nut (item 97.1, Appx G)

#### a. Removal

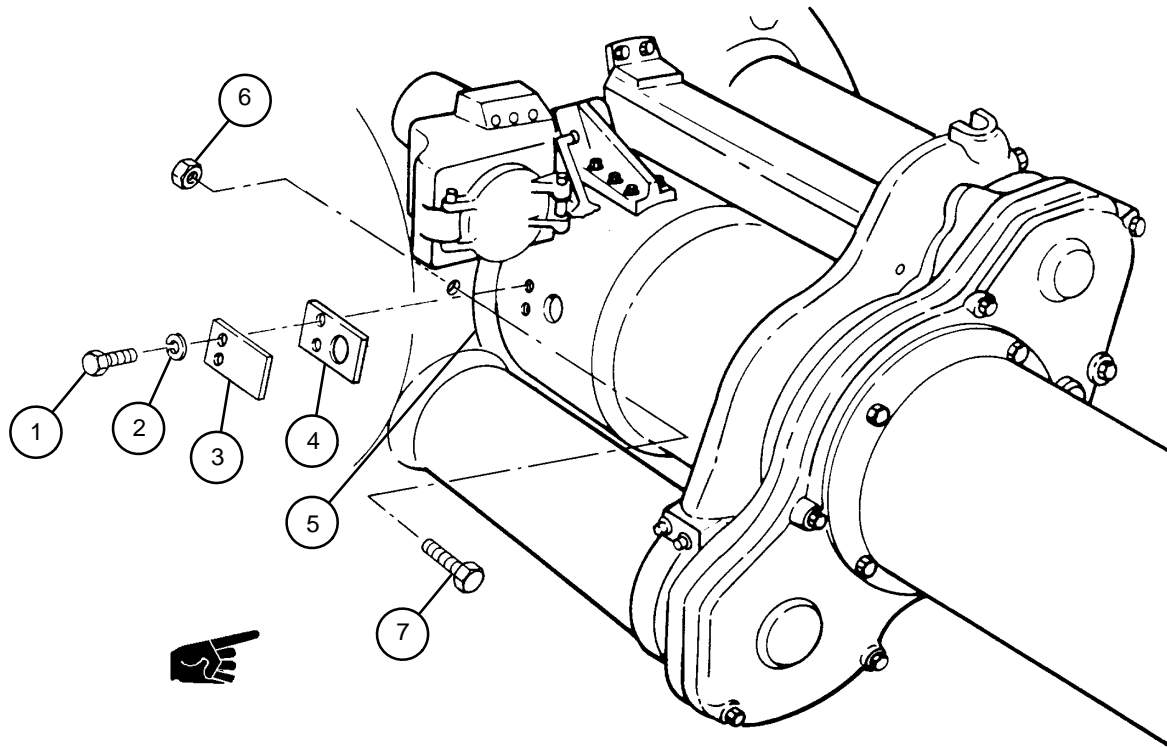
#### NOTE

Access cover should only be removed if there is any damage to parts.

- 1 Remove two machine bolts (1), two lockwashers (2), access cover (3), and gasket (4) from cradle (5). Discard lockwashers and gasket.
- 2 Remove self-locking nut (6) and cap screw (7). Discard self-locking nut.

#### b. Installation

- 1 Install cap screw (7) and new self-locking nut (6).
- 2 Install new gasket (4) and access cover (3) to outside of cradle (5) and secure using two new lockwashers (2) and two machine bolts (1).







---

## 5-19 REPLENISHER ACCUMULATOR ASSEMBLY — CONTINUED

---

### a. Removal — Continued

#### NOTE

Draining system in step 2 will drain only buffer assembly and replenisher accumulator.

- 2 Drain recoil mechanism hydraulic fluids by disconnecting hydraulic tube (3) at buffer assembly (4). Catch hydraulic fluid in utility pail.

**WARNING**

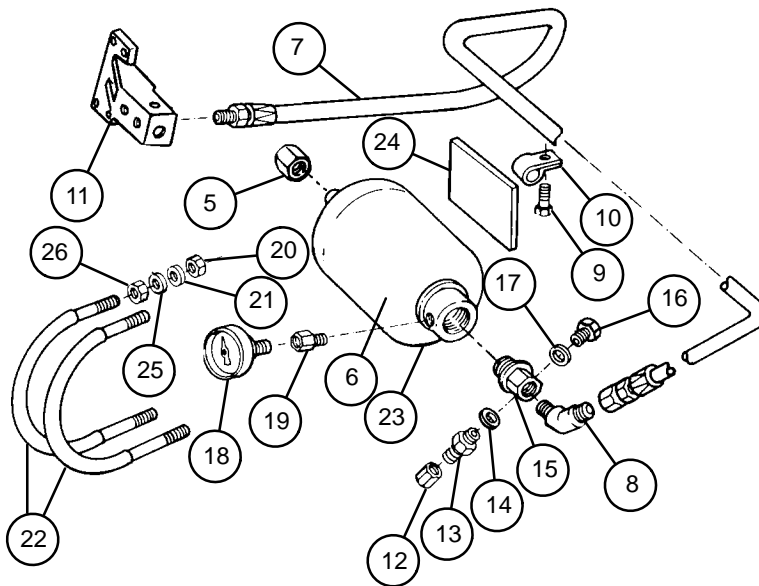
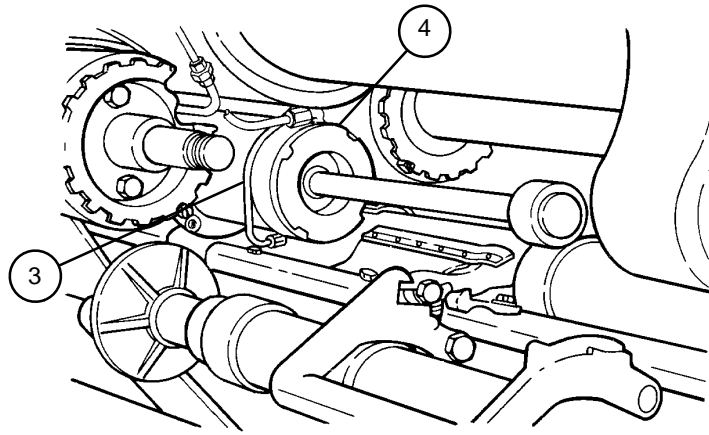
Replenisher accumulator contains pressurized nitrogen. Do not disassemble until all pressure is relieved to avoid injury to personnel.

- 3 Remove valve cap (5) and release nitrogen pressure from accumulator bag (6).
- 4 Disconnect hose assembly (7) at elbow (8).
- 5 To remove hose assembly (7), remove six cap screws (9) from six clamps (10). Remove six clamps from hose assembly.
- 6 Disconnect hose assembly (7) and remove from manifold (11).
- 7 Remove valve cap (12), check valve (13), and preformed packing (14) from adapter (15). Discard preformed packing.
- 8 Remove plug (16) and preformed packing (17) from adapter (15). Discard preformed packing.
- 9 Remove elbow (8) and adapter (15).
- 10 Remove pressure gage (18) and coupling (19).

**WARNING**

Weight of replenisher accumulator is 65 pounds (30 kg). A second person must support replenisher accumulator inside cab to prevent injury to personnel.

- 11 Remove four self-locking nuts (20) and four flat washers (21) from two U-bolts (22) on right front of cab. Discard self-locking nuts.
- 12 Remove two U-bolts (22), replenisher accumulator (23), and cushioning pad (24) from cab wall by removing four flat washers (25) and four inside hex nuts (26).



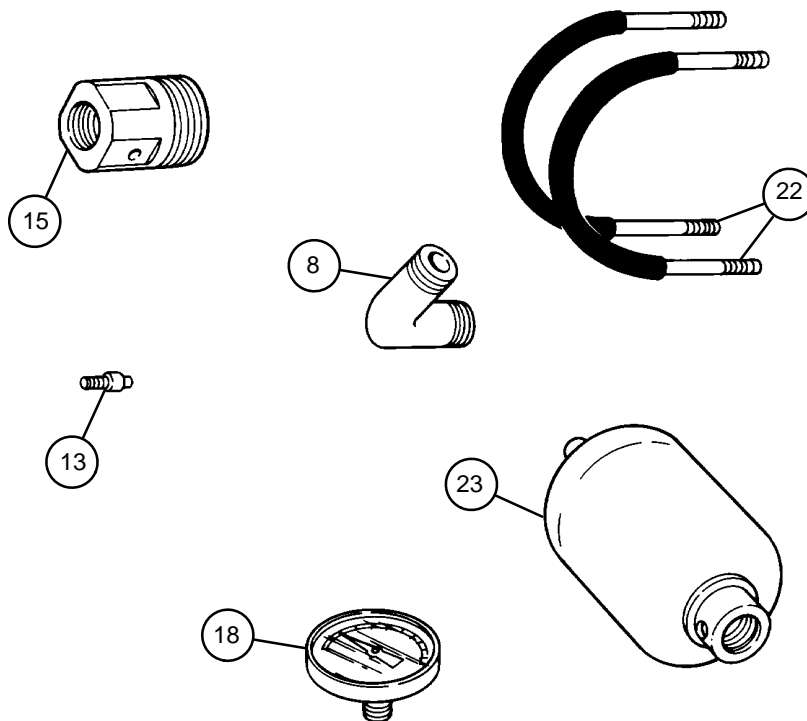
---

## 5-19 REPLENISHER ACCUMULATOR ASSEMBLY — CONTINUED

---

### b. Inspection

- 1 Inspect elbow (8). Replace if gouged or if threads are stripped.
- 2 Inspect adapter (15). Replace if surfaces are damaged and threads are stripped.
- 3 Inspect check valve (13). Replace if worn or damaged.
- 4 Inspect two U-bolts (22). Replace if bent, distorted, or if threads are stripped.
- 5 Inspect replenisher accumulator (23) for cracks and distortion. Notify support maintenance if damaged.
- 6 Inspect pressure gage (18) for damage. Replace if necessary.



### c. Installation

- 1 Install coupling (19) and pressure gage (18) on replenisher accumulator (23).
- 2 Install new preformed packing (14), check valve (13), valve cap (12), and elbow (8) onto adapter (15).
- 3 Install new preformed packing (17) and plug (16) onto adapter (15).

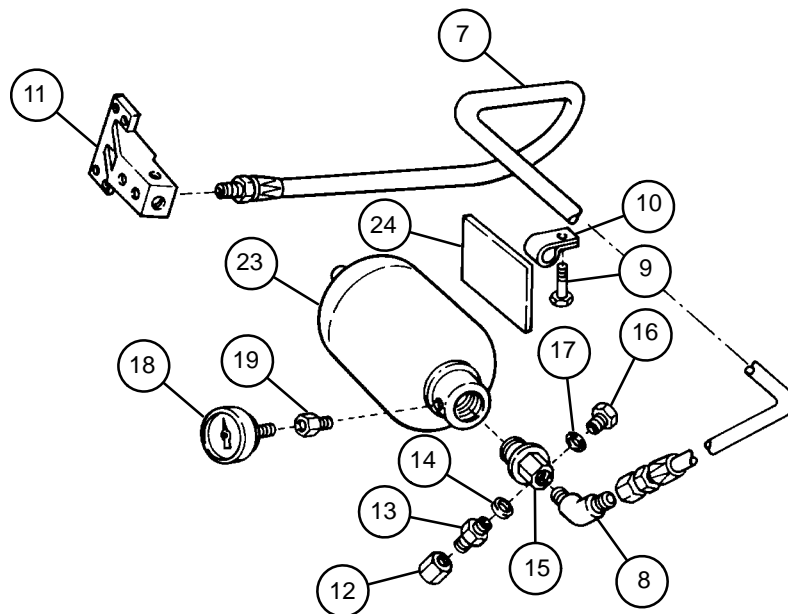
#### NOTE

- Replenisher accumulator assembly can be precharged with dry nitrogen before installation to cab (para 19-1). Before installing adapter to accumulators, add additional hydraulic fluid to the shell, approximately 1 gallon (0.836 l).
  - If accumulator replenisher assembly is to be precharged after installation proceed with step 4.
- 4 Install adapter (15) in housing of replenisher accumulator (23).
  - 5 Attach six clamps (10) to hose assembly (7). Apply sealing compound to shafts of six cap screws (9). Install six cap screws in six clamps. Torque cap screws to 9 lb-ft (12 N·m).

#### WARNING

Adhesives can burn easily, can give off harmful vapors, and are harmful to skin and clothing. To avoid injury or death, keep away from open fire and use in well-ventilated area. If adhesive gets on skin or clothing, wash immediately with soap and water.

- 6 Apply adhesive to cushioning pad (24) and cab wall. Install cushioning pad on cab wall.
- 7 Connect hose assembly (7) to manifold (11) and to elbow (8). Tighten swivel fitting.



---

## 5–19 REPLENISHER ACCUMULATOR ASSEMBLY — CONTINUED

---

### c. Installation — Continued

#### NOTE

If not precharged before installation proceed with step 8.

- 8 Inject enough hydraulic fluid into replenisher accumulator (23) through check valve (13) to provide fluid cushion. (Capacity is 2.5 gallons (9.46 l)).
- 9 Precharge replenisher accumulator (para 19–1).

#### NOTE

If cap MS20813–1 is present on gas valve, retain for valve cap 9399173.

- 10 Install valve cap (5).

**WARNING**

Weight of replenisher accumulator is 65 pounds (30 kg). A second person must support replenisher accumulator inside cab when installing to prevent injury to personnel.

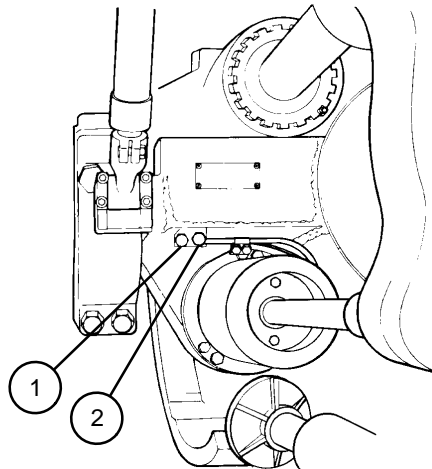
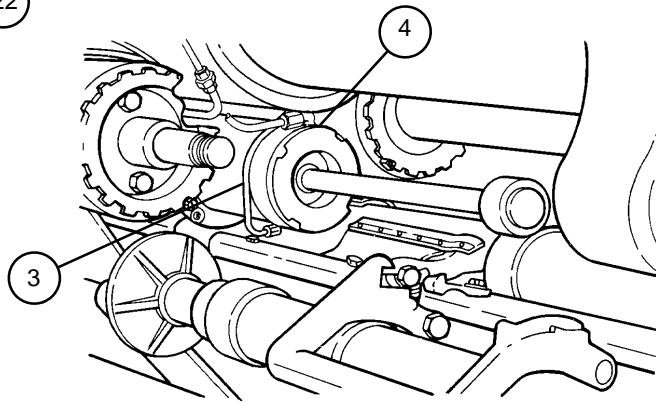
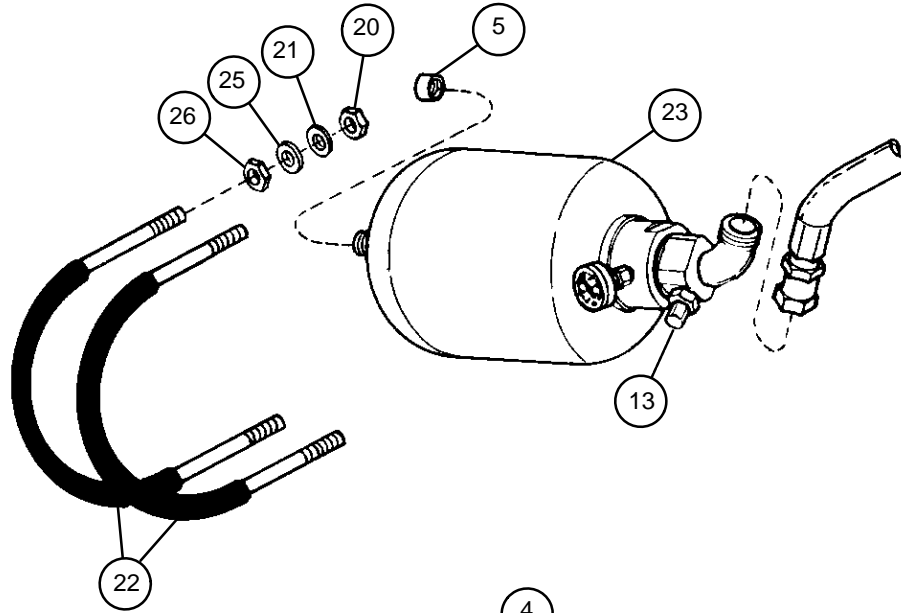
#### NOTE

Inside hex nuts and flat washers on U-bolts must not be in contact with cab wall until outside self-locking nuts have been torqued.

- 11 Install four inside nuts (26) and four flat washers (25). Tighten four inside nuts.
- 12 Secure accumulator (23) and two U-bolts (22) to cab wall with four flat washers (21) and four new self-locking nuts (20) on outside. Torque to 10–15 lb–ft (13–20 N·m).
- 13 Connect hydraulic tube (3) at buffer assembly (4).
- 14 Close left-hand plug (1) on buffer coupling block (2).
- 15 Charge replenisher system with hydraulic fluid (TM 9–2350–311–10).

### d. Service

Service replenisher accumulator (23) (para 19–1).









---

## 5-21 CRADLE AND HOWITZER ACCESS COVERS — CONTINUED

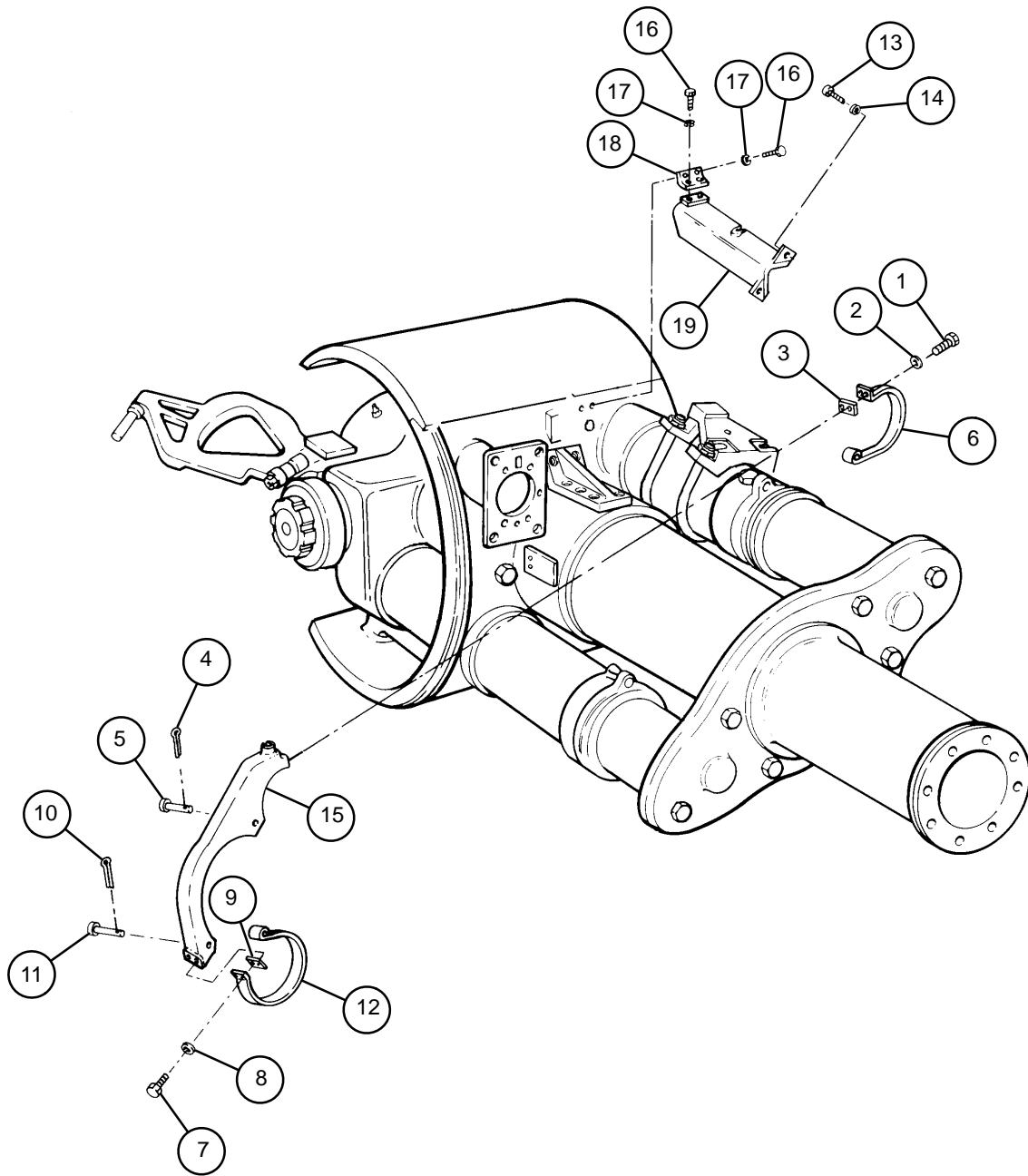
---

### a. Removal – Continued

- 7 Remove two cap screws (13), two flat washers (14), and access cover (15).
- 8 Remove four cap screws (16), four lockwashers (17), angle bracket (18), and access cover (19). Discard lockwashers.

### b. Installation

- 1 Position access cover (19) and angle bracket (18) and secure with four new lockwashers (17) and four cap screws (16).
- 2 Position access cover (15) and secure with two flat washers (14) and two cap screws (13).
- 3 Position retaining band (12) and secure to access cover (15) with headed straight pin (11).
- 4 Install new cotter pin (10).
- 5 Position retaining band (6) and secure to access cover (15) with headed straight pin (5).
- 6 Install new cotter pin (4).
- 7 Install plate spacer (9), two flat washers (8), and two cap screws (7).
- 8 Install plate spacer (3), two flat washers (2), and two cap screws (1).





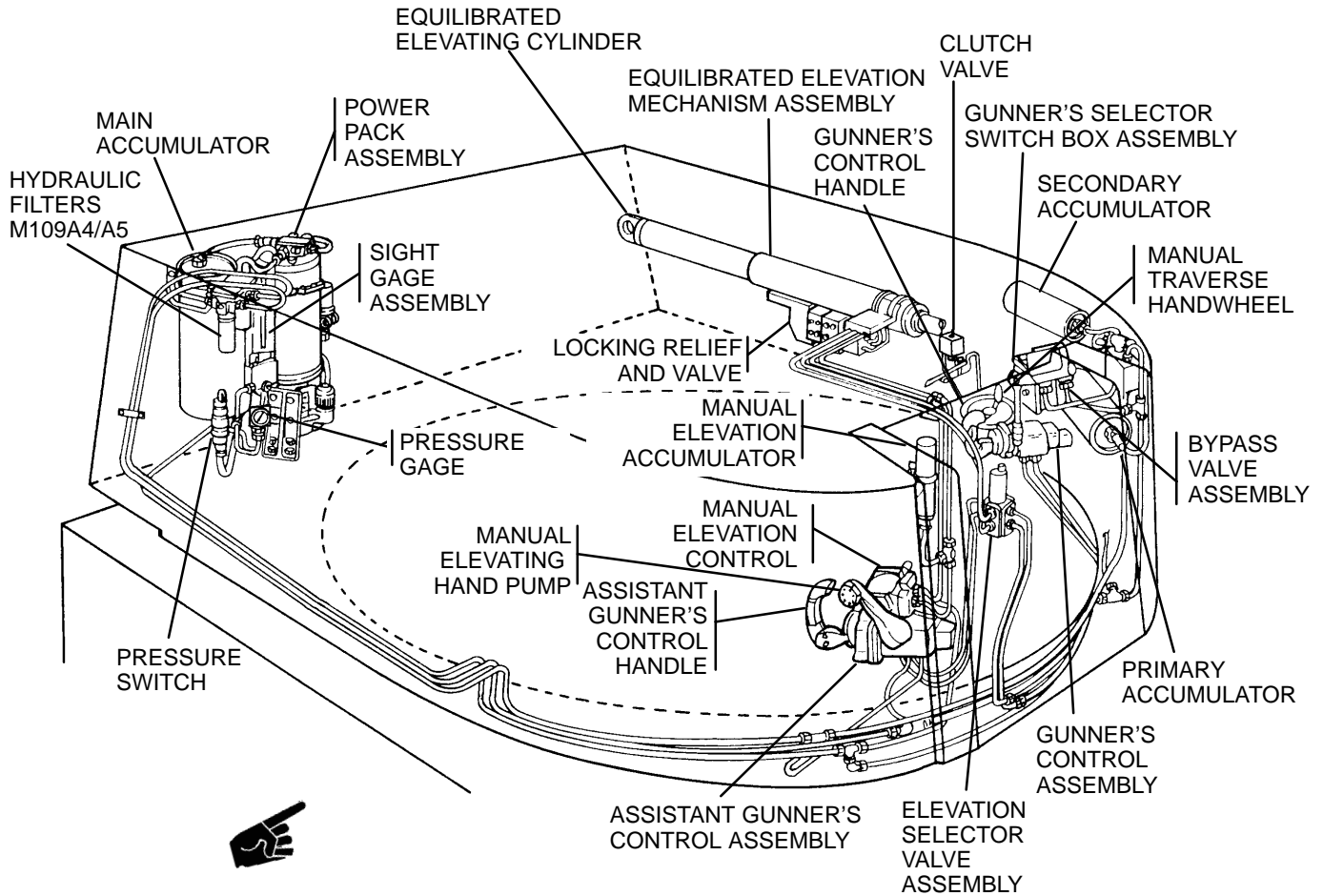
## CHAPTER 6 CAB HYDRAULICS

### GENERAL

This chapter describes unit maintenance procedures for cab hydraulic system.

<u>CONTENTS</u>	<u>Page</u>
6-1 GAGE ASSEMBLY, SIGHT .....	6-3
6-2 POWER PACK, HYDRAULIC (FLUID LEVEL) .....	6-7
6-3 POWER PACK, HYDRAULIC (DRAINING, FILLING AND CHARGING) .....	6-9
6-3.1 EQUILIBRATED ELEVATION MECHANISM ASSEMBLY .....	6-14
6-4 POWER PACK STRAINER .....	6-18
6-5 POWER PACK SOLENOID .....	6-19
6-6 PRESSURE SWITCH, HYDRAULIC .....	6-20
6-7 BYPASS VALVE ASSEMBLY .....	6-21
6-8 CLUTCH VALVE .....	6-23
6-9 ACCUMULATOR ASSEMBLY (MANUAL PUMP) .....	6-25
6-10 ACCUMULATOR ASSEMBLY (MAIN) .....	6-28
6-11 ACCUMULATOR ASSEMBLY (PRIMARY) .....	6-30
6-12 ACCUMULATOR ASSEMBLY (SECONDARY) .....	6-32
6-13 EQUILIBRATION MANIFOLD ASSEMBLY .....	6-34
6-14 EQUILIBRATION HANDPUMP ASSEMBLY .....	6-36
6-15 MANUAL ELEVATION PUMP ASSEMBLY .....	6-38
6-16 ELEVATION SELECTOR VALVE ASSEMBLY .....	6-40
6-17 HYDRAULIC FILTER ASSEMBLY .....	6-42
6-18 HYGROSCOPIC BREATHER AND AIR LINE FILTER .....	6-46
6-19 GUNNER'S CONTROL ASSEMBLY .....	6-48
6-20 ASSISTANT GUNNER'S CONTROL ASSEMBLY .....	6-50
6-21 GUNNER'S/ASSISTANT GUNNER'S CONTROL ASSEMBLY HANDLES .....	6-52
6-22 LINES AND FITTINGS FROM POWER PACK TO PRESSURE SWITCH AND GAGES .....	6-54
6-23 LINES AND FITTINGS FROM CAB TO POWER PACK .....	6-60
6-24 LINES AND FITTINGS FROM HYDRAULIC FILTERS .....	6-62
6-25 LINES AND FITTINGS FROM PRIMARY AND SECONDARY ACCUMULATORS TO EQUILIBRATED ELEVATING CYLINDER .....	6-64
6-26 LINES AND FITTINGS FROM TRAVERSING MECHANISM .....	6-68
6-27 LINES AND FITTINGS FROM CLUTCH VALVE .....	6-72
6-28 LINES AND FITTINGS FROM MANUAL ACCUMULATOR ASSEMBLY .....	6-74
6-29 LINES AND FITTINGS FROM ELEVATION SELECTOR VALVE ASSEMBLY .....	6-76
6-30 LINES AND FITTINGS FROM ELEVATION EQUILIBRATION CYLINDER .....	6-80

HYDRAULICS LOCATOR





6-1 GAGE ASSEMBLY, SIGHT — CONTINUED

NOTE

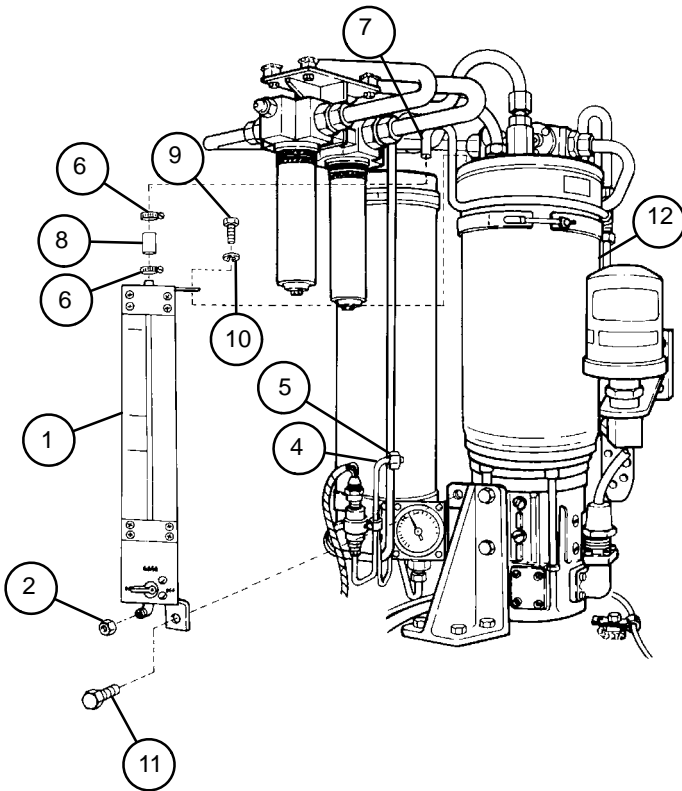
If plug is not available to plug tube, reservoir must be drained (para 6-3) prior to disconnecting tube.

- 2 Disconnect bent metallic tube (4) from sight gage (1) by unscrewing coupling nut (5). Install plug (2) to prevent hydraulic fluid from draining.

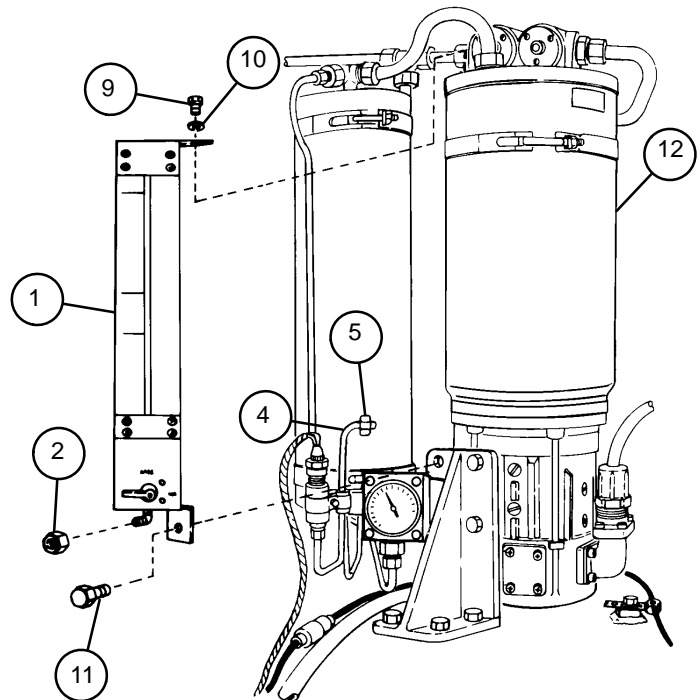
NOTE

Step 3 only pertains to M109A4/M109A5 howitzers.

- 3 Loosen two hose clamps (6) and disconnect bent metallic tube (7) from top of sight gage (1). Remove hose clamps and 2-inch hose (8).
- 4 Remove machine bolt (9) and lockwasher (10) from top of sight gage (1) and cap screw (11) near bottom and remove sight gage from power pack assembly (12).



M109A4/M109A5 HOWITZER



M109A2/M109A3 HOWITZER

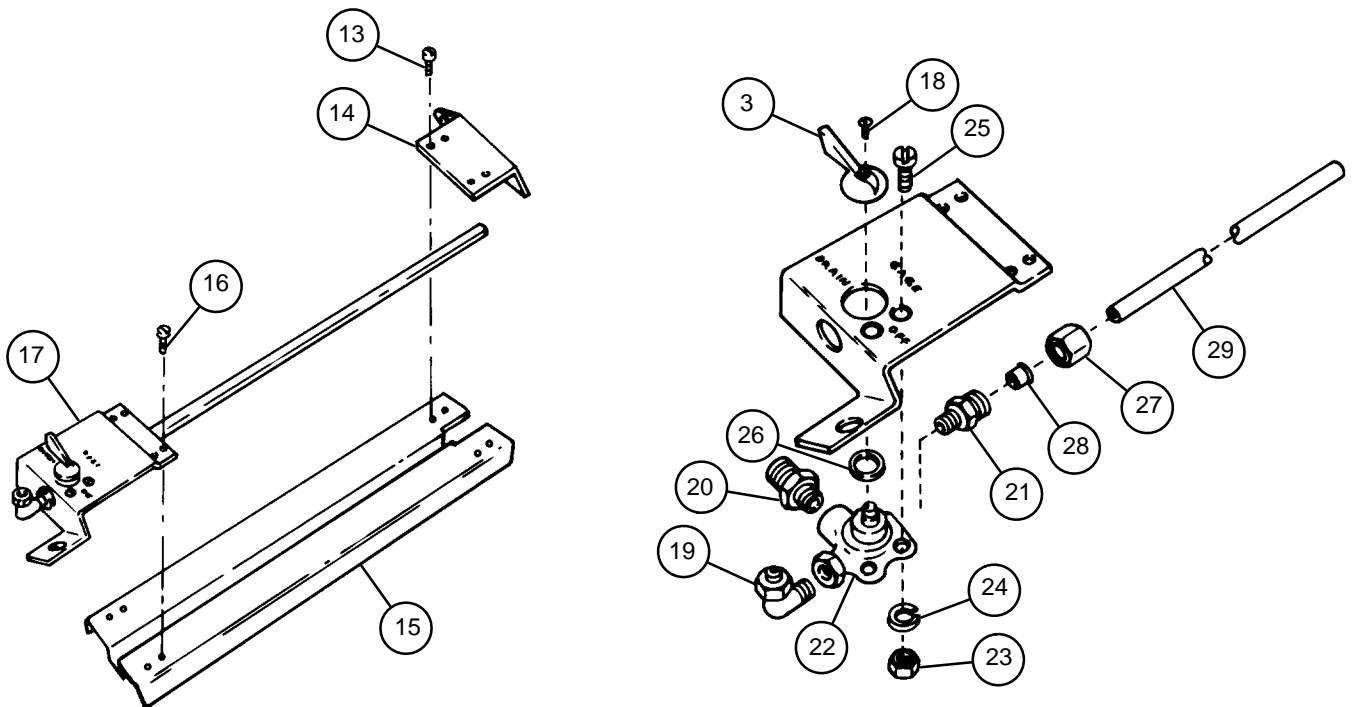


**b. Disassembly**

- 1 Remove four tapping screws (13) and mounting bracket (14) from instruction plate (15).
- 2 Remove four tapping screws (16) and sight gage bracket (17) from instruction plate (15).
- 3 Remove screw (18) and pointer handle (3).
- 4 Remove elbow (19) and adapters (20 and 21) from valve assembly (22).
- 5 Remove two hex nuts (23), two lockwashers (24), and two machine screws (25). Remove valve assembly (22) and flat washer(s) (26) from sight gage bracket (17). Discard lockwashers.
- 6 Remove flat washer (27), clinch sleeve (28), and nonmetallic tubing (29) from adapter (21).

**c. Assembly**

- 1 Install clinch sleeve (28), flat washer (27), and nonmetallic tubing (29) on adapter (21).
- 2 Install adapters (20 and 21) and elbow (19) on valve assembly (22).
- 3 Install flat washer(s) (26) on valve assembly (22). Add or subtract flat washer(s), as required, to align non-metallic tubing (29) on sight gage (1). Using two machine screws (25), two new lockwashers (24), and two hex nuts (23), attach valve assembly (22) to sight gage bracket (17).
- 4 Install pointer handle (3) and screw (18).
- 5 Install sight gage bracket (17) and four tapping screws (16) on instruction plate (15).
- 6 Install mounting bracket (14) and four tapping screws (13) on instruction plate (15).



**6-1 GAGE ASSEMBLY, SIGHT — CONTINUED**

**d. Installation**

- 1 Using machine bolt (9) and new lockwasher (10) at top of sight gage (1) and cap screw (11) near bottom of sight gage, attach sight gage to power pack assembly (12).

**NOTE**

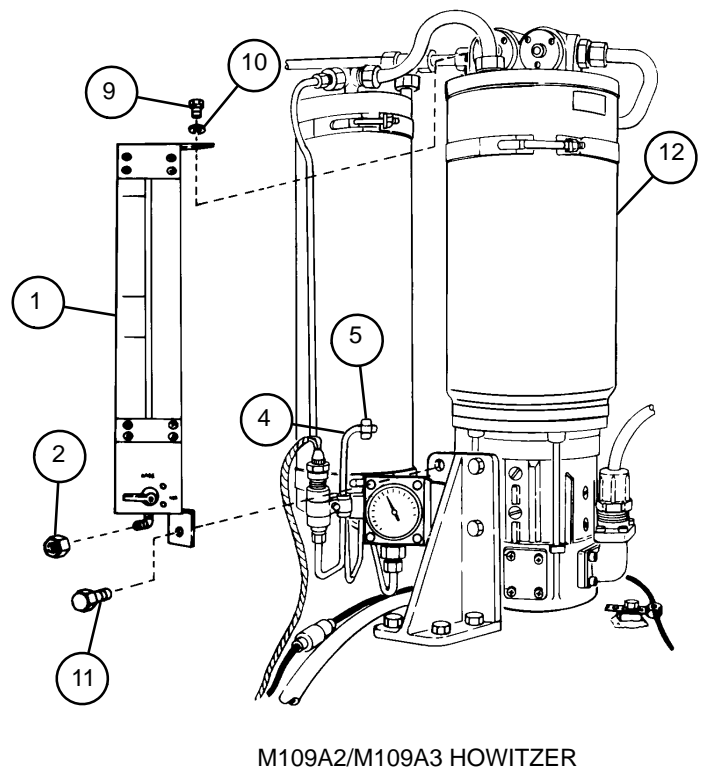
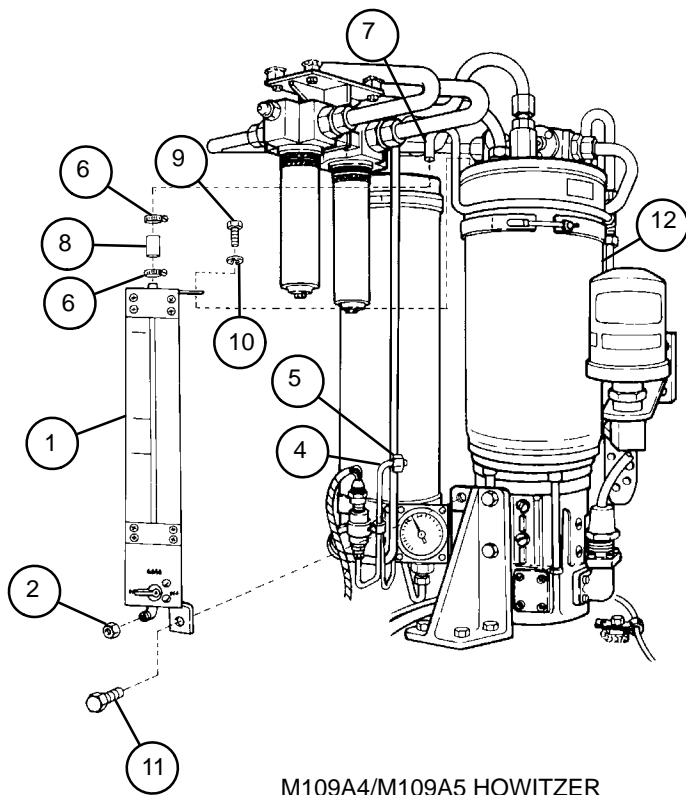
Steps 2 and 3 pertain only to M109A4/M109A5 howitzers.

- 2 Attach 2-inch hose (8) to bent metallic tube (7) at top of sight gage (1).
- 3 Install two hose clamps (6) and bent metallic tube (7); tighten hose clamps.

**NOTE**

Ensure valve assembly is in GAGE position.

- 4 Remove plug (2) from bent metallic tube (4). Install bent metallic tube by tightening coupling nut (5) to sight gage (1).
- 5 Install plug (2).
- 6 Check hydraulic fluid level (para 6-2).



## 6-2 POWER PACK, HYDRAULIC (FLUID LEVEL)

This task covers: Checking Fluid Level and Adding Fluid

### INITIAL SETUP

#### Tools

Artillery and turret mechanic's tool kit  
(SC 5180-95-CL-A12)

#### Materials/Parts

Hydraulic fluid, OHT (item 21, Appx D)

#### Personnel Required

2

#### Equipment Condition

Discharge hydraulic pressure (para 6-3)

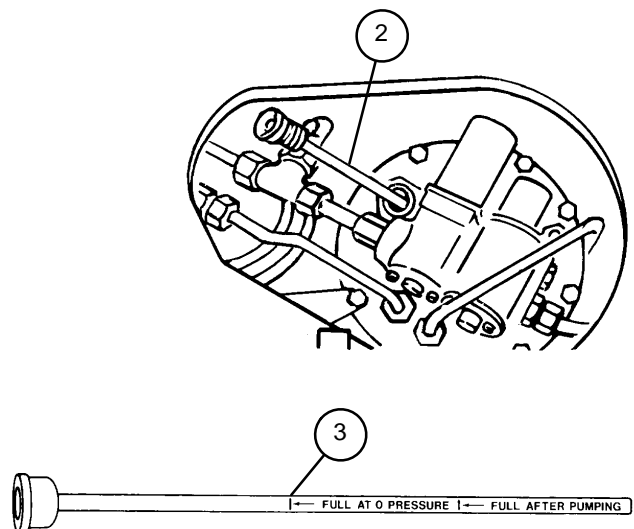
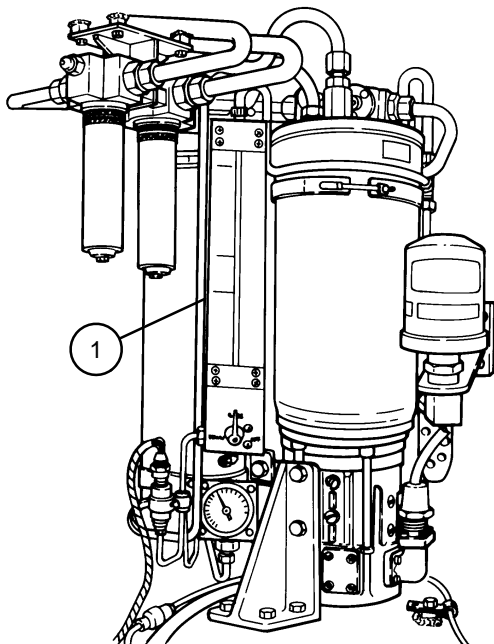
Tow cable and cab access cover removed (para 14-11)

Park vehicle on level ground

CAB POWER switch to OFF (TM 9-2350-311-10)

### Checking Fluid Level and Adding Fluid

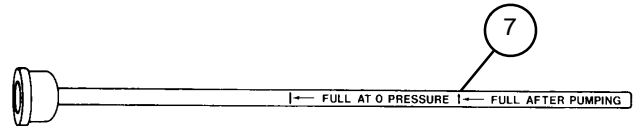
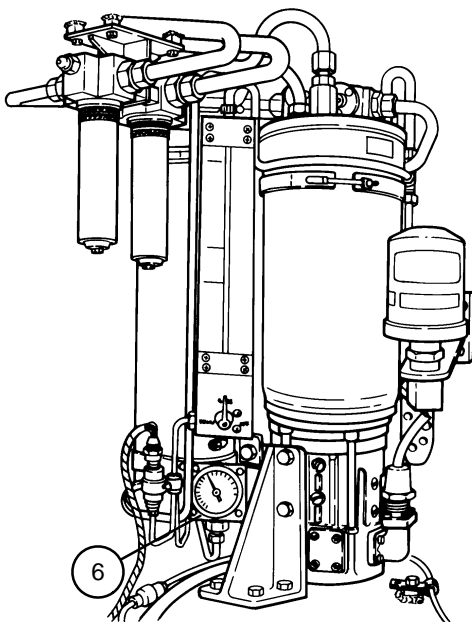
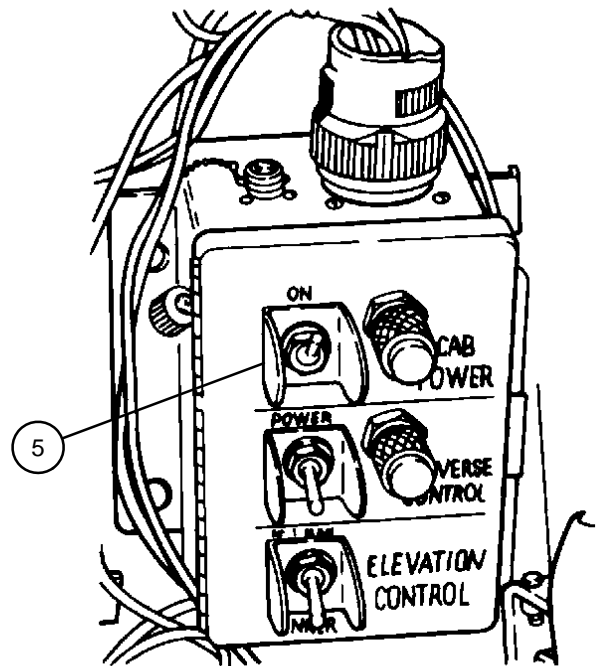
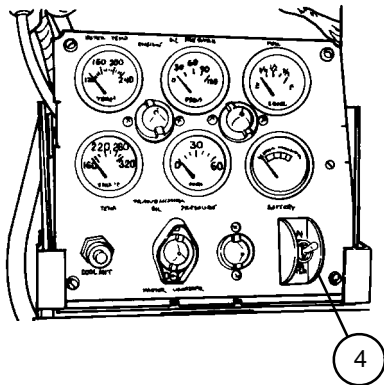
- 1 Visually check fluid level in sight gage (1).
- 2 Physically check fluid level in power pack reservoir:
  - (a) Remove power pack gage (2) and check fluid level. It should read FULL AT 0 PRESSURE mark (3).
  - (b) If required, add hydraulic fluid until it reaches proper level on power pack gage (2).
  - (c) Install power pack gage (2).



6-2 POWER PACK, HYDRAULIC (FLUID LEVEL) — CONTINUED

Checking Fluid Level and Adding Fluid — Continued

- Turn MASTER switch (4) and CAB POWER switch (5) to ON. When pressure gage (6) reads between 925 and 1225 psi (6378 to 8446 kPa), fluid level should be at FULL AFTER PUMPING mark (7). If not, add hydraulic fluid per paragraph 6-3c.



M109A4/M109A5 HOWITZER

## 6-3 POWER PACK, HYDRAULIC (DRAINING, FILLING AND CHARGING)

This task covers:    a. Discharging Pressure                      b. Draining Fluid  
                               c. Filling    d. Charging

### INITIAL SETUP

Tools

Artillery and turret mechanic's tool kit  
 (SC 5180-95-CL-A12)  
 Drain pan (item 8, Appx H)  
 Utility pail (item 7, Appx H)

Materials/Parts

Caps and plugs (item 7, Appx D)

Hydraulic fluid, OHT (item 21, Appx D)

Equipment Condition

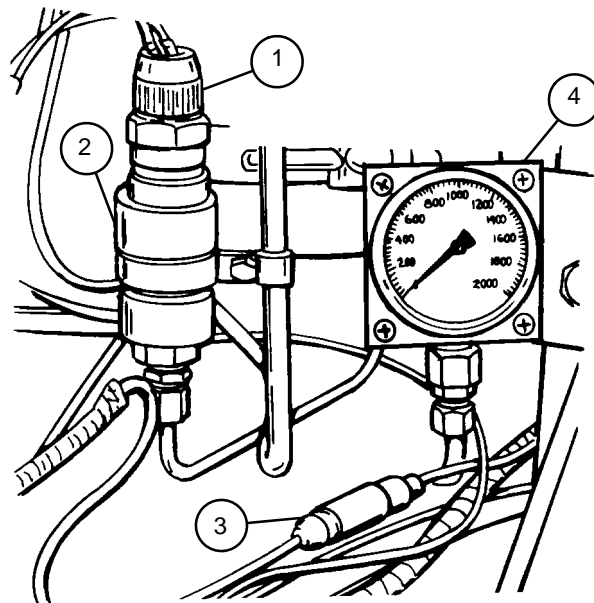
Tow cable and cab access cover removed (para 14-11)  
 Cab traverse lock locked (TM 9-2350-311-10)  
 Vehicle MASTER switch to OFF (TM 9-2350-311-10)  
 CAB POWER switch to OFF (TM 9-2350-311-10)  
 TRAVERSE CONTROL switch in MANUAL position  
 (TM 9-2350-311-10)

### a. Discharging Pressure

**CAUTION**

All hydraulic lines and ports must be capped to prevent contaminants from entering the hydraulic system and causing internal damage to hydraulic components.

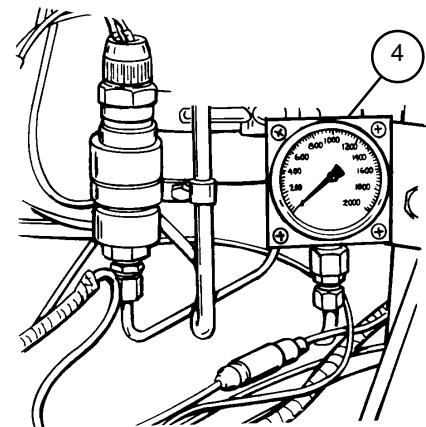
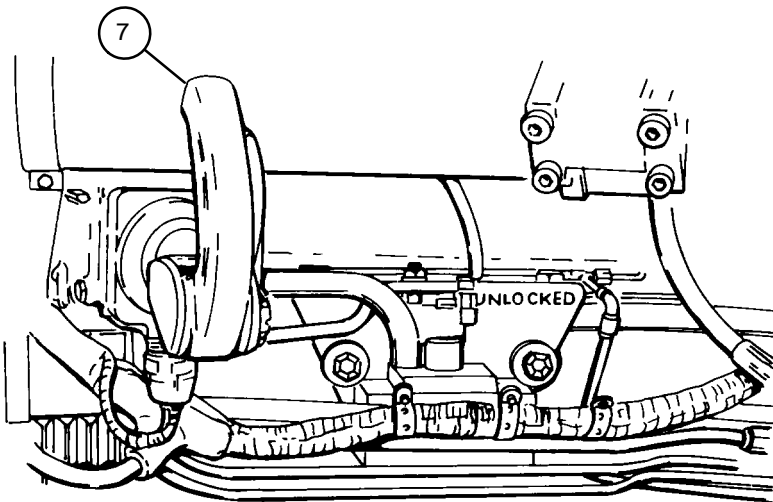
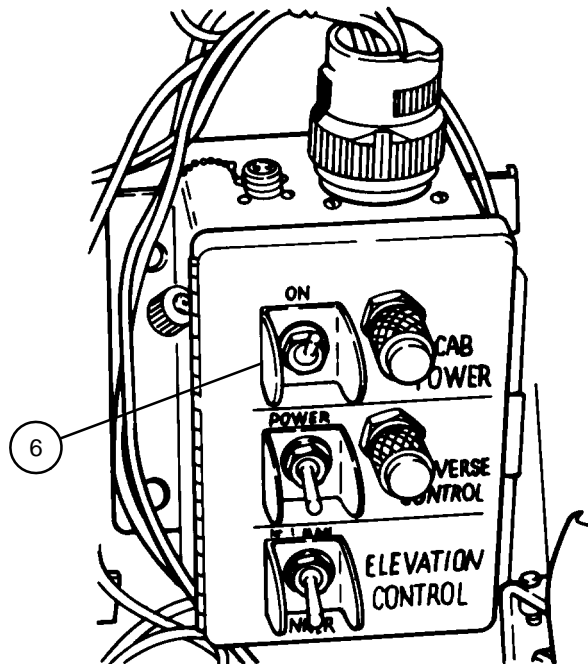
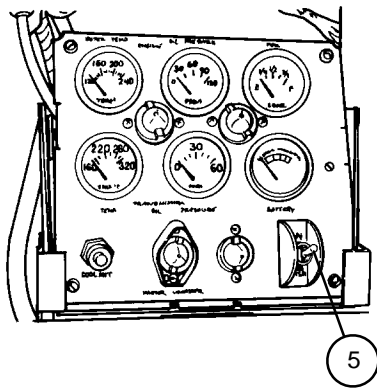
- 1    Disconnect wire 645 (1) at pressure switch (2) or at quick disconnect (3) near pressure gage (4).



6-3 POWER PACK, HYDRAULIC (DRAINING, FILLING AND CHARGING) — CONTINUED

a. Discharging Pressure — Continued

- 2 Set MASTER switch (5) and CAB POWER switch (6) to ON.
- 3 Turn gunner's control handle (7) to right or left to discharge pressure.
- 4 Monitor pressure gage (4) until system pressure falls to 0 psi (0 kPa).



## b. Draining Fluid

### NOTE

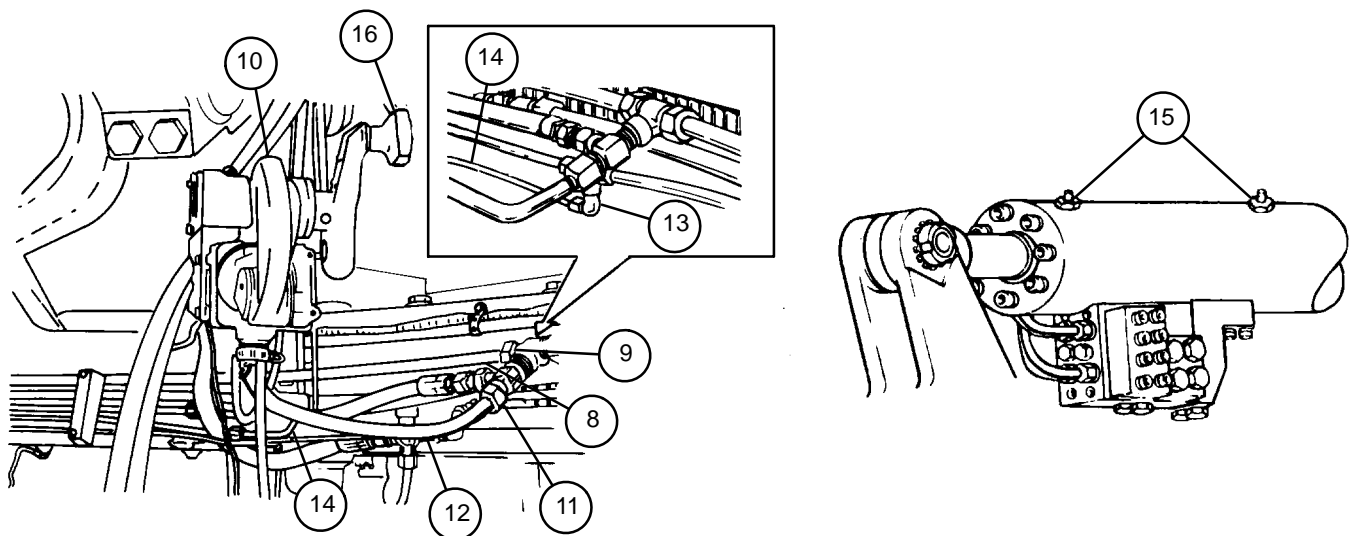
- Be sure the power pack pressure system has been discharged (para 6-3a.) before draining hydraulic fluid.
- Dispose of hydraulic fluid in accordance with local regulations.

- 1 Place a drain pan under tee on main return tube (8).
- 2 Loosen hex nut (9) and disconnect main return tube (8). Drain tube into drain pan.
- 3 Move assistant gunner's control handle (10) back and forth to drain elevating tubes.
- 4 Loosen hex nut (11) and disconnect charging tube (12). Drain into drain pan.
- 5 Loosen elbow (13) and disconnect traversing motor drain tube (14). Drain into drain pan.

### NOTE

Open bleed valves slowly to prevent hydraulic fluid and air from mixing.

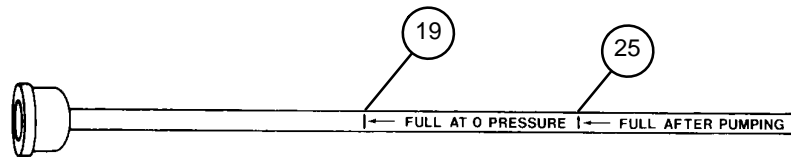
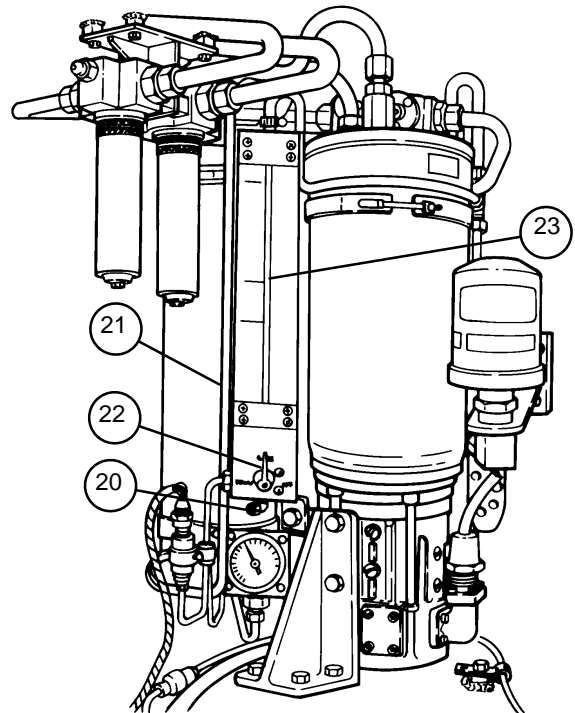
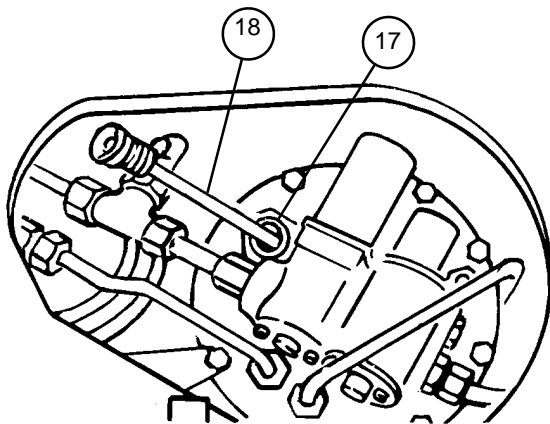
- 6 Place a utility pail under each elevating cylinder bleed valve (15). Open elevating cylinder bleed valves and drain.
- 7 Turn elevating hand pump (16) in both directions. Totally drain hydraulic system.
- 8 Close elevating cylinder bleed valves (15).
- 9 Connect main return tube (8), charging tube (12), and traversing motor drain tube (14). Tighten hex nuts (9 and 11) and elbow (13).



**6-3 POWER PACK, HYDRAULIC (DRAINING, FILLING AND CHARGING) — CONTINUED**

**c. Filling**

- 1 Fill power pack reservoir with hydraulic fluid at power pack gage opening (17) (para 2-9).
- 2 Check power pack gage (18) for fluid level. Fill to FULL AT 0 PRESSURE mark (19). If power pack reservoir is overfilled, go to step 3.
- 3 Loosen plug (20) at sight gage (21).
- 4 Turn pointer handle (22) to DRAIN position.
- 5 Check fluid level in tube (23) on sight gage (21). When fluid level reaches FULL AT 0 PRESSURE mark (19), turn pointer handle (22) to GAGE position and tighten plug (20).



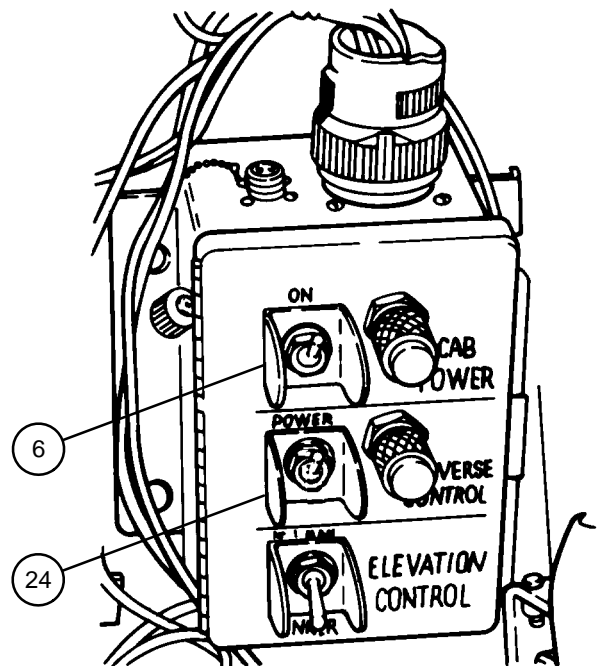
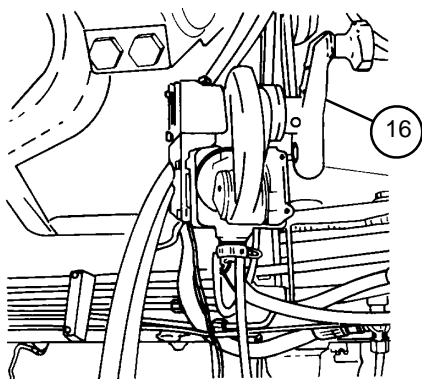
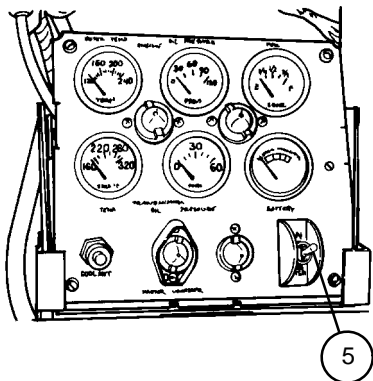


d. Charging

**CAUTION**

If hydraulic pressure reaches 1400 psi (9653 kPa), immediately turn CAB POWER switch to OFF to avoid damaging system. Discharge hydraulic system (para 6-3a.), and turn CAB POWER switch to ON. If pressure again reaches 1400 psi (9653 kPa), turn CAB POWER switch to OFF and troubleshoot the pressure switch.

- 1 Lower travel lock and unlock turret lock (TM 9-2350-311-10).
- 2 Turn MASTER switch (5) and CAB POWER switch (6) to ON to charge elevating and traversing systems.
- 3 Rotate elevating hand pump (16) clockwise until movement of elevation cylinder is detected.
- 4 Turn TRAVERSE CONTROL switch (24) to POWER position. Traverse cab one full revolution in each direction.
- 5 Set MASTER switch (5) and CAB POWER switch (6) to OFF.
- 6 Check hydraulic fluid level at sight gage (21). Fluid must be at FULL AFTER PUMPING mark (25). If necessary, add hydraulic fluid (para 6-3c.).



---

## 6-3.1 EQUILIBRATED ELEVATION MECHANISM ASSEMBLY

---

This task covers:    a. Discharging Pressure                      b. Bleeding  
                              c. Adjustment

---

### **INITIAL SETUP**

Tools

Artillery and turret mechanic's tool kit  
(SC 5180-95-CL-A12)

Utility pail (item 7, Appx H)

Materials/Parts

Hydraulic fluid, OHT (item 21, Appx D)

---

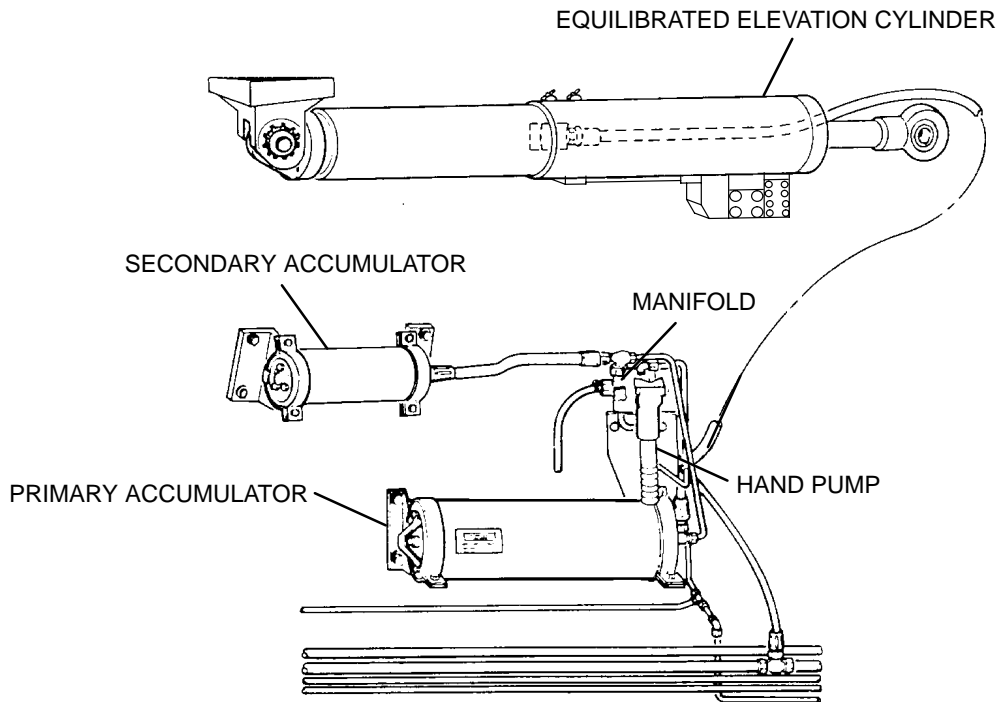
#### a. Discharging Pressure

**WARNING**

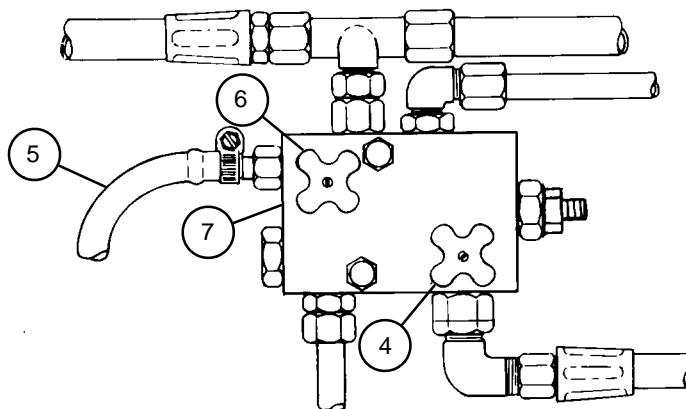
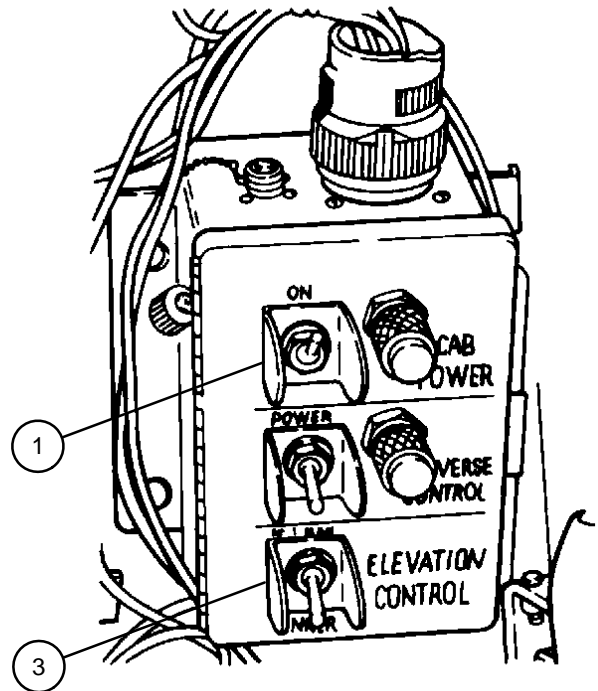
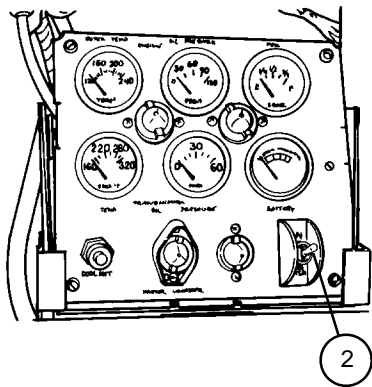
Accumulator contains high pressure nitrogen. Use caution when handling and working with it to avoid injury.

**NOTE**

You may have to repeat the bleed procedure several times. Check fluid level in power pack reservoir after each bleed sequence and add hydraulic fluid as required (para 6-3c.).



- 1 Turn CAB POWER switch (1) and MASTER switch (2) to OFF and ELEVATION CONTROL switch (3) to No. 1 MAN position.
- 2 Lower travel lock and unlock turret lock (TM 9-2350-311-10).
- 3 Turn MASTER switch (2) and CAB POWER switch (1) to ON. Put ELEVATION CONTROL switch (3) in GUNNER position. Fully depress cannon tube (-53 mils).
- 4 Check equilibrator valve knob (4) to make sure it is closed.
- 5 Place utility pail under drain tube (5). Open drain valve knob (6) on equilibration manifold assembly (7). When hydraulic fluid stops flowing through drain tube, close drain valve knob to shut off drain.



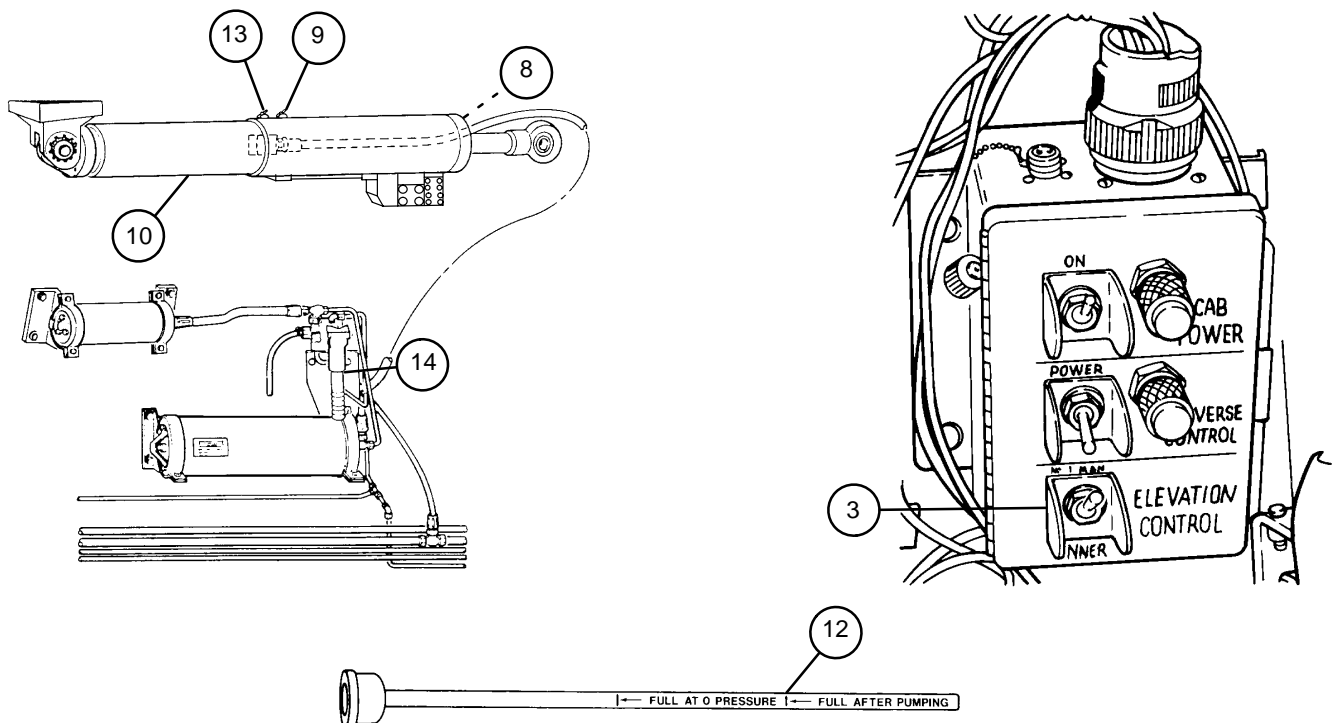
## 6-3.1 EQUILIBRATED ELEVATION MECHANISM ASSEMBLY — CONTINUED

### b. Bleeding

**WARNING**

Bleed valves may have high pressure when first opened. Use caution when opening valves to avoid injury.

- 1 Open bleed valves (8 and 9) on elevating cylinder (10).
- 2 Place ELEVATION CONTROL switch (3) to NO. 1 MAN position.
- 3 Pull back slowly on assistant gunner's control handle (11) until air-free hydraulic fluid flows from bleed valve (8). Then close bleed valve.
- 4 Push forward slowly on assistant gunner's control handle (11) until air-free hydraulic fluid flows from bleed valve (9). Then, close bleed valve.
- 5 Refill hydraulic power pack reservoir to FULL AFTER PUMPING mark (12) (para 6-3c.).
- 6 Ensure equilibrator valve knob (4) is closed on equilibrator manifold assembly (7). Make sure that howitzer tube is fully depressed.
- 7 Open rear bleed valve (13) on elevating cylinder (10).
- 8 Pump equilibrator hand pump (14) until air-free hydraulic fluid flows from rear bleed valve (13). Then close rear bleed valve.



### c. Adjustment.

- 1 Open equilibrator valve knob (4). Leave open approximately 15 seconds, then close.
- 2 Operate equilibrator hand pump (14) and assistant gunner's control handle (11), alternating from one to the other until the howitzer tube raises to maximum elevation.

#### NOTE

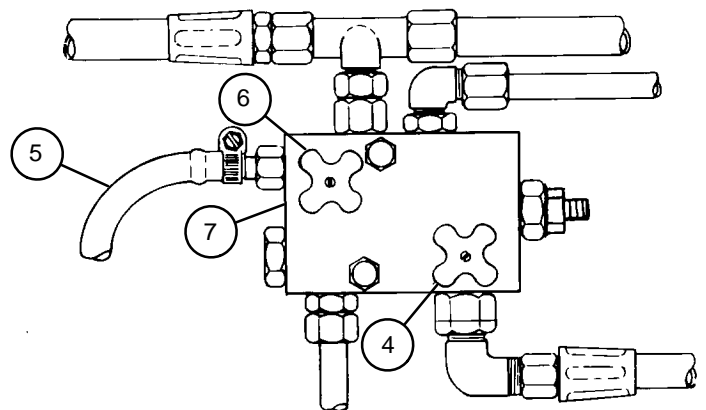
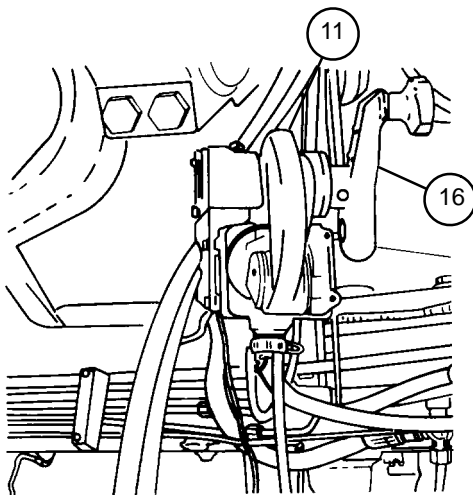
The next step is to ensure equilibration system is not overfilled with hydraulic fluid which will cause relief valve to open and spill hydraulic fluid at power pack sight gage when cannon is depressed.

- 3 With cannon tube at maximum elevation, open equilibrator valve knob (4). Leave open approximately 15 seconds, then close.
- 4 Depress howitzer tube to balance point of +266 mils.
- 5 Use elevating hand pump (16) to elevate and depress howitzer tube.

#### NOTE

If possible, use two personnel to perform task to reduce time required.

- (a) If howitzer tube is harder to elevate than depress, increase equilibrator pressure with equilibrator hand pump (14).
  - (b) If howitzer tube is harder to depress than elevate, reduce pressure by draining fluid. Place utility pail under drain tube (5) and turn open drain valve knob (6).
  - (c) Repeat steps (a) and (b) until howitzer tube balances.
- 6 If required, fill reservoir to FULL AFTER PUMPING mark (12) (para 6-3c.).





## 6-5 POWER PACK SOLENOID

This task covers: a. Removal b. Installation

### INITIAL SETUP

#### Tools

Artillery and turret mechanic's tool kit  
(SC 5180-95-CL-A12)

#### Materials/Parts

Gasket (item 180, Appx G)

Lockwashers (4) (item 182, Appx G)

#### Equipment Condition

Tow cable and cab access cover removed (para 14-11)  
Discharge hydraulic pressure (para 6-3)  
CAB POWER switch to OFF (TM 9-2350-311-10)  
Vehicle MASTER switch to OFF (TM 9-2350-311-10)

### a. Removal

- 1 Disconnect wire 625A (1) from power pack solenoid (2).

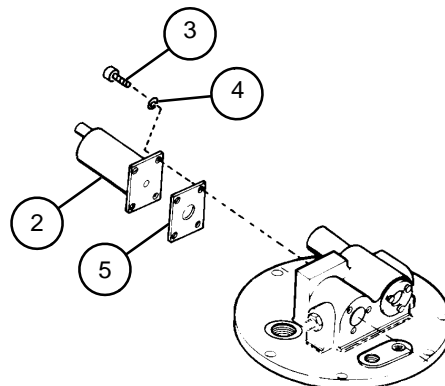
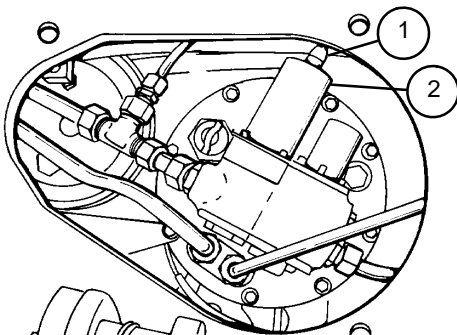
#### NOTE

Remove power pack solenoid with care, as spring-held spool is held in body by power pack solenoid.

- 2 Remove four socket head cap screws (3), four lockwashers (4), power pack solenoid (2), and gasket (5). Discard lockwashers and gasket.

### b. Installation

- 1 Install new gasket (5), power pack solenoid (2), four new lockwashers (4), and four socket head cap screws (3).
- 2 Connect wire 625A (1) to power pack solenoid (2).



---

## 6-6 PRESSURE SWITCH, HYDRAULIC

---

This task covers: a. Removal b. Installation

---

### INITIAL SETUP

#### Tools

Artillery and turret mechanic's tool kit  
(SC 5180-95-CL-A12)

#### Materials/Parts

Caps and plugs (item 7, Appx D)

Preformed packing (item 46, Appx G)

#### Equipment Condition

Discharge hydraulic pressure (para 6-3)

CAB POWER switch to OFF (TM 9-2350-311-10)

Vehicle MASTER switch to OFF (TM 9-2350-311-10)

---

### CAUTION

All hydraulic lines and ports must be capped to prevent contaminants from entering the hydraulic system and causing internal damage to hydraulic components.

### NOTE

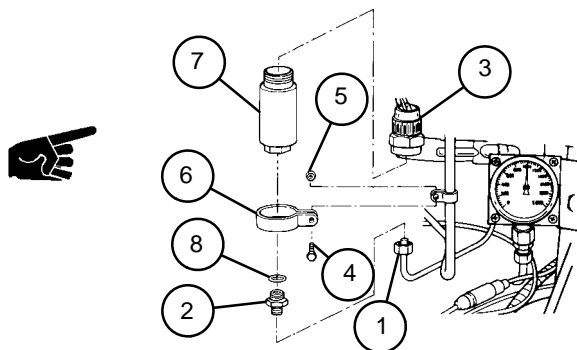
Dispose of hydraulic fluid in accordance with local regulations.

#### a. Removal

- 1 Disconnect tube nut (1) from reducer (2) and plug hydraulic line.
- 2 Disconnect connector (3).
- 3 Remove machine bolt (4), hex nut (5), and loop clamp (6).
- 4 Remove pressure switch (7).
- 5 Remove reducer (2) and preformed packing (8). Discard preformed packing.

#### b. Installation

- 1 Install reducer (2) and new preformed packing (8) into pressure switch (7).
- 2 Install pressure switch (7) in loop clamp (6).
- 3 Secure loop clamp (6) with hex nut (5) and machine bolt (4).
- 4 Connect connector (3).
- 5 Remove plug and connect tube nut (1) to reducer (2).
- 6 Check hydraulic fluid level (para 6-2).





## 6-7 BYPASS VALVE ASSEMBLY

This task covers: a. Removal b. Installation

### INITIAL SETUP

#### Tools

Artillery and turret mechanic's tool kit  
(SC 5180-95-CL-A12)

Utility pail (item 7, Appx H)

#### Materials/Parts

Cap and plug set (item 7, Appx D)

Lockwashers (2) (item 67, Appx G)

Lockwashers (4) (item 78, Appx G)

Preformed packings (2) (item 47, Appx G)

#### Equipment Condition

Discharge hydraulic pressure (para 6-3)

CAB POWER switch to OFF (TM 9-2350-311-10)

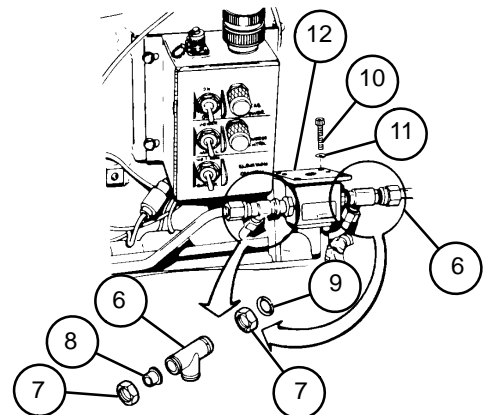
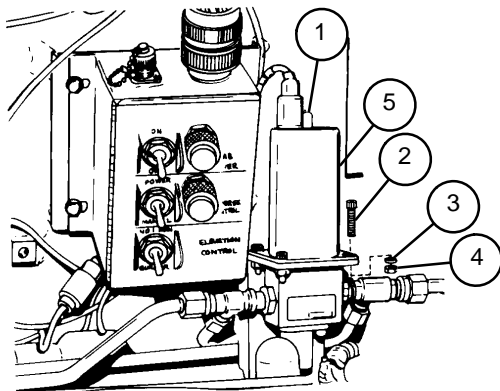
Vehicle MASTER switch to OFF (TM 9-2350-311-10)

### a. Removal

- 1 Disconnect electrical connector (1).
- 2 Remove four cap screws (2), four lockwashers (3), and four hex nuts (4). Discard lockwashers.
- 3 Remove solenoid (5) from bypass valve assembly.

#### NOTE

- Restrict the removal of hydraulic tubes and fittings to those items that are to be replaced.
  - All hydraulic lines and fittings must be capped to prevent contaminants from entering the hydraulic system and causing internal damage to hydraulic components.
  - Dispose of hydraulic fluid in accordance with local regulations.
- 4 Remove two tees (6), four hex nuts (7), two clinch sleeves (8), and two preformed packings (9). Discard preformed packings. Drain lines at point of disconnect into utility pail.
  - 5 Remove two cap screws (10) and two lockwashers (11). Discard lockwashers.
  - 6 Remove valve body (12).



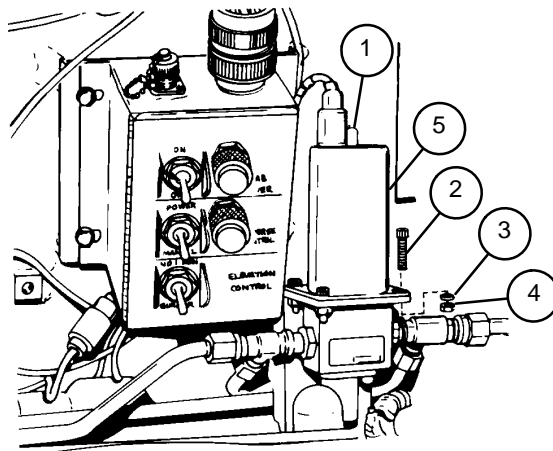
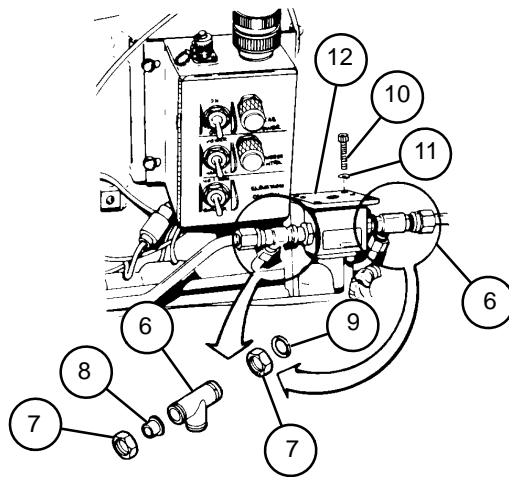
---

## 6-7 BYPASS VALVE ASSEMBLY — CONTINUED

---

### b. Installation

- 1 Using two new lockwashers (11) and two cap screws (10), install valve body (12).
- 2 Insert two new preformed packings (9) into tee receptacles on each side of valve body (12). Install four hex nuts (7) and two clinch sleeves (8) on two tees (6). Install two tees on valve body.
- 3 Using four nuts (4), four new lockwashers (3), and four cap screws (2), install solenoid (5) on valve body (12).
- 4 Connect electrical connector (1) to solenoid (5).
- 5 Check hydraulic fluid level (para 6-2).



## 6-8 CLUTCH VALVE

This task covers: a. Removal

b. Installation

### INITIAL SETUP

Applicable Configuration

M109A4/M109A5 howitzers

Tools

Artillery and turret mechanic's tool kit  
(CL 5180-95-A12, see SC 9999-01-SKO)

Materials/Parts

Caps and plugs (item 7, Appx D)

Lockwashers (2) (item 68, Appx G)

Lockwashers (3) (item 84, Appx G)

Preformed packings (3) (item 46, Appx G)

Tag, marking (item 36, Appx D)

Equipment Condition

Discharge hydraulic pressure (para 6-3)

CAB POWER switch to OFF (TM 9-2350-311-10)

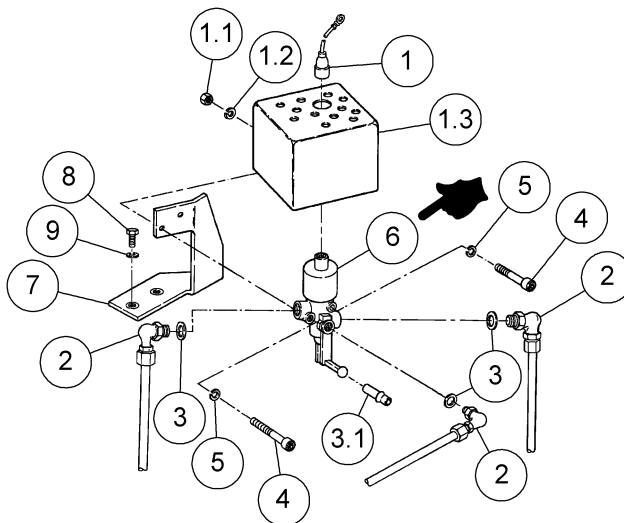
Vehicle MASTER switch to OFF (TM 9-2350-311-10)

### a. Removal

#### CAUTION

All hydraulic lines and ports must be capped to prevent contaminants from entering the hydraulic system and causing internal damage to hydraulic components.

- 1 Disconnect electrical connector (1).
- 2 Remove nut (1.1), lockwasher (1.2), and heat shield (1.3). Discard lockwasher.
- 3 Tag hydraulic lines. Remove three elbows (2) with attached lines and three preformed packings (3). Discard preformed packings.
- 4 Remove insulation sleeving (3.1), if necessary, from clutch valve (6).
- 5 Remove two cap screws (4), two lockwashers (5), and clutch valve (6) from mounting bracket (7). Discard lockwashers.
- 6 If necessary for maintenance, remove mounting bracket (7) by removing two machine screws (8) and two lockwashers (9). Discard lockwashers.

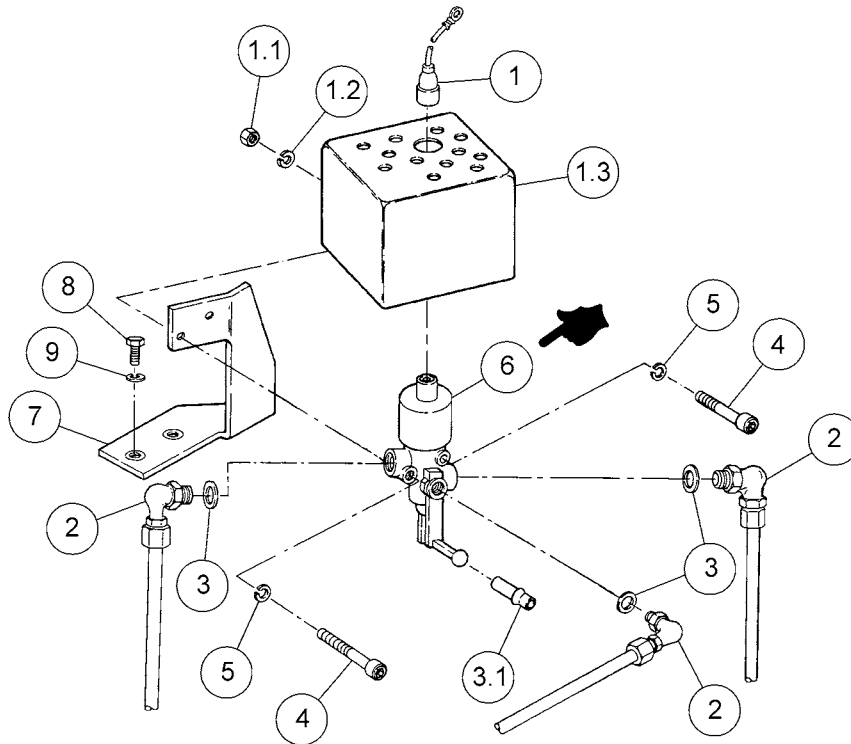


m16m109084c

## 6-8 CLUTCH VALVE — CONTINUED

### b. Installation

- 1 If removed, install mounting bracket (7) and secure with two new lockwashers (9) and two machine screws (8).
- 2 Install clutch valve (6) and secure with two new lockwashers (5) and two cap screws (4).
- 3 Install new insulation sleeving (3.1), if removed.
- 4 Install three new preformed packings (3) and three elbows (2) with attached lines. Remove tags.
- 5 Install heat shield (1.3) over clutch valve (6) and secure with new lockwasher (1.2) and hex nut (1.1).
- 6 Connect electrical connector (1).
- 7 Check hydraulic fluid level (para 6-2).



m16m109083c



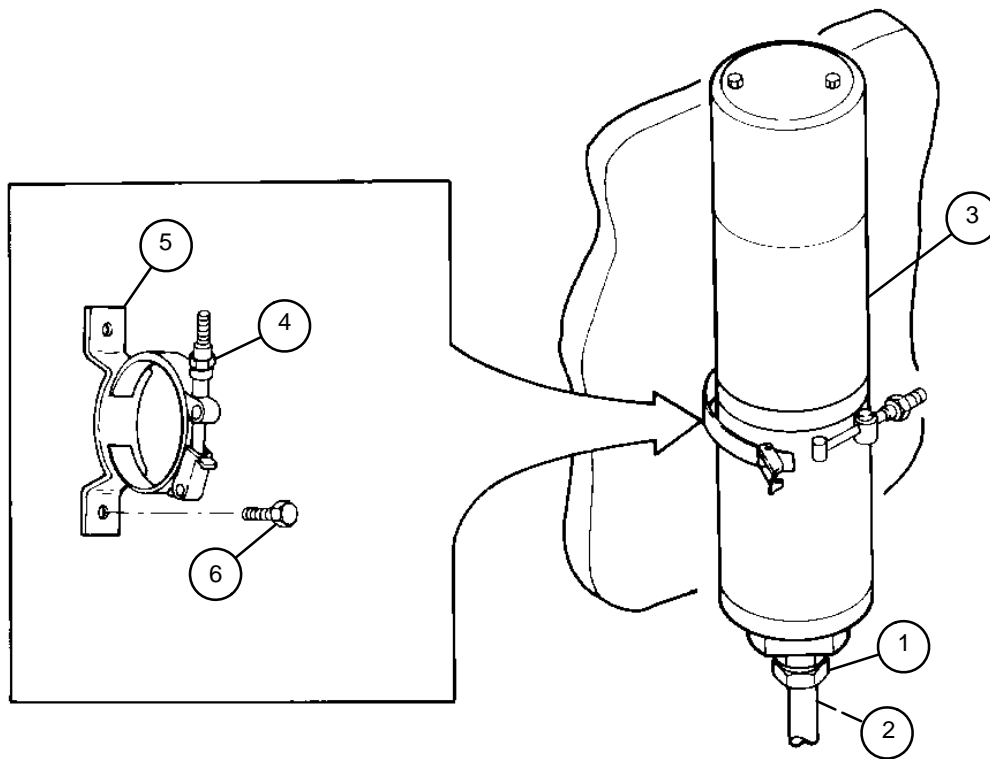
---

## 6-9 ACCUMULATOR ASSEMBLY (MANUAL PUMP) — CONTINUED

---

### c. Installation

- 1 If removed, install loop clamp (5) with two cap screws (6).
- 2 Insert accumulator (3) into loop clamp (5) and secure with nut (4).
- 3 Connect hydraulic line to base of accumulator (3). Tighten hex nut (1) over clinch sleeve (2) to secure line.
- 4 Check hydraulic fluid level (para 6-2).



**d. Testing**

- 1 Loosen two hex nuts (7) at ports M-1 and M-2. Drain fluids from manual elevation tubes (8) into utility pail.
- 2 Remove accumulator cap (9) and air valve cap (10) from accumulator (3).

**NOTE**

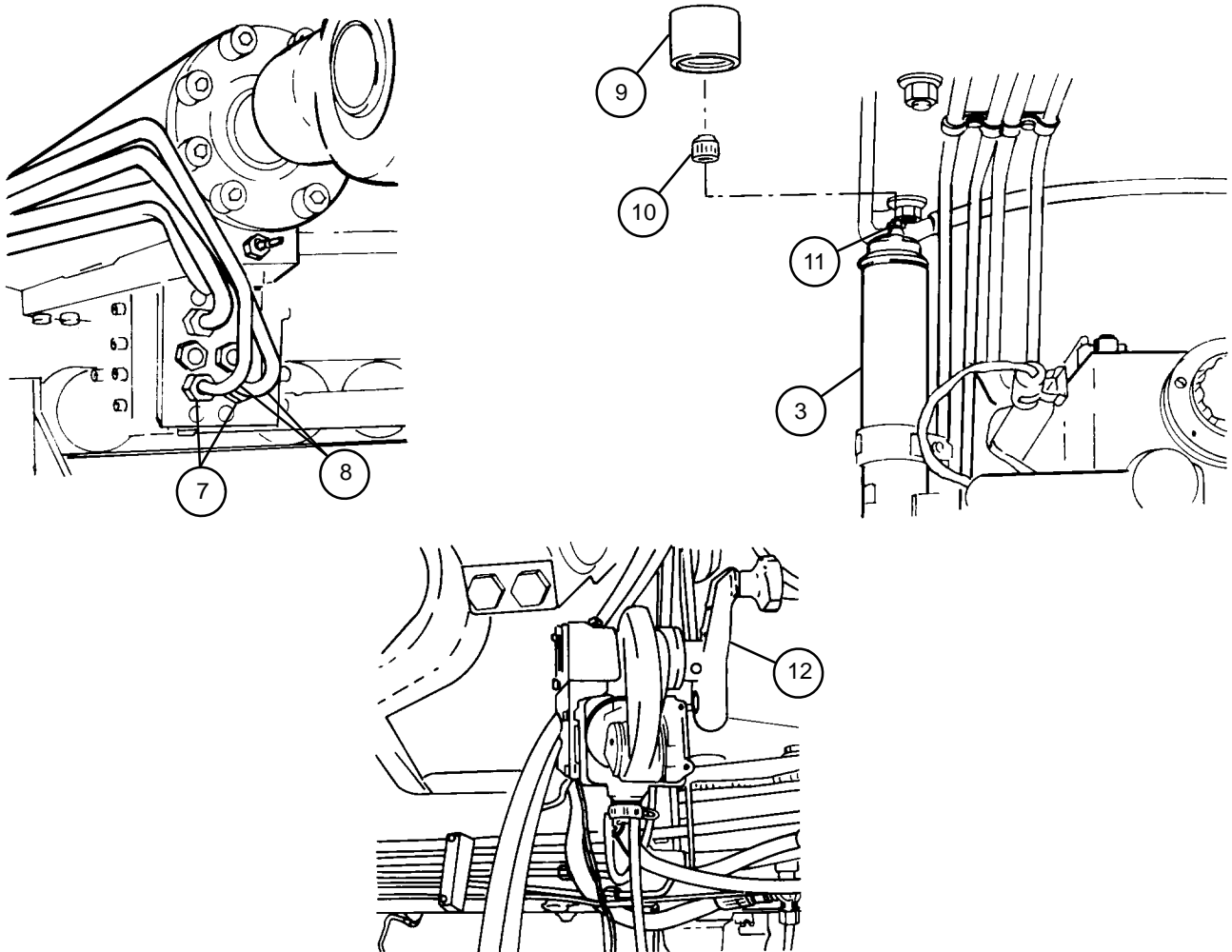
Each check with tire pressure gage will deplete pressure by approximately 20 psi (137.90 kPa).

- 3 Use tire pressure gage to check nitrogen pressure at valve (11).

**NOTE**

If precharged pressure is below 75 psi (517 kPa), charge the accumulator (para 19-3).

- 4 Tighten two hex nuts (7) to secure manual elevation tubes (8).
- 5 Install air valve cap (10) and accumulator cap (9) on accumulator (3).
- 6 Rotate manual elevation hand pump handle (12) counterclockwise. Rotate until movement is detected in elevating cylinder. Then, bleed elevating cylinder (para 6-3a.).



## 6-10 ACCUMULATOR ASSEMBLY (MAIN)

This task covers: a. Testing

b. Service

### INITIAL SETUP

Tools

Artillery and turret mechanic's tool kit  
(SC 5180-95-CL-A12)

Equipment Condition

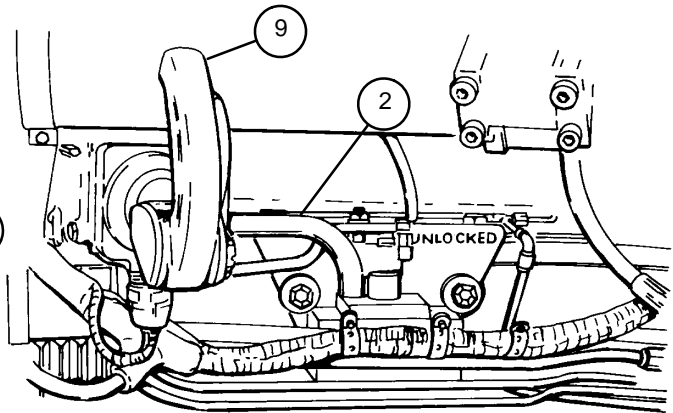
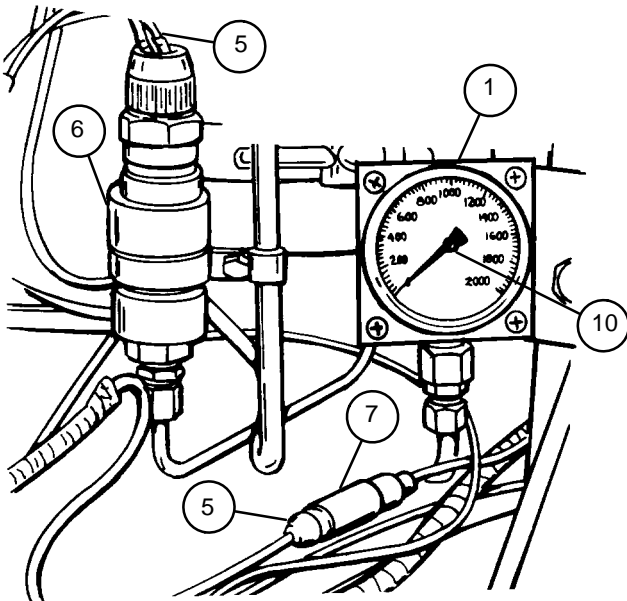
CAB POWER switch to ON (TM 9-2350-311-10)  
Vehicle MASTER switch to ON (TM 9-2350-311-10)

#### a. Testing

#### NOTE

Testing should be done at a temperature of 60°F to 125°F (15.6°C to 51.7°C) with vehicle on level ground if possible.

- 1 Check pressure gage (1). Normal range is 925 to 1225 psi (6378 to 8446 kPa).
- 2 Move traversing lock handle (2) to the LOCKED position or place cannon tube in travel lock.
- 3 Turn MASTER switch (3) and CAB POWER switch (4) to OFF.
- 4 Disconnect wire 645 (5) at pressure switch (6) or at quick-disconnect (7) near pressure switch.
- 5 Turn TRAVERSE CONTROL switch (8) to MANUAL position.
- 6 Turn MASTER switch (3) and CAB POWER switch (4) to ON.





- 7 Move gunner's control handle (9) slowly left or right. Note that pressure gage needle (10) will move.
- 8 Watch pressure gage needle (10) as it drops from operating pressure until it flutters, then drops sharply to 0 psi (0 kPa). The reading at which the pressure gage needle fluttered is the amount of precharged nitrogen in the main accumulator. Precharged nitrogen pressure in the main accumulator must be from 500 to 550 psi (3448 to 3792 kPa) at the local surrounding temperature.

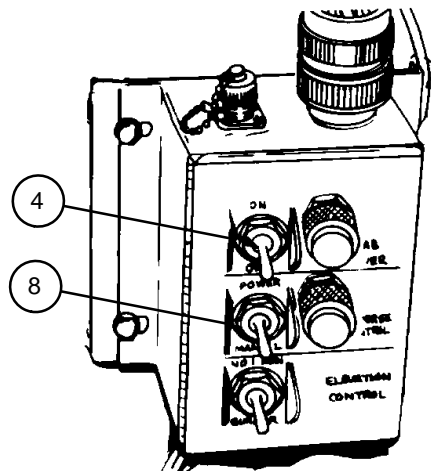
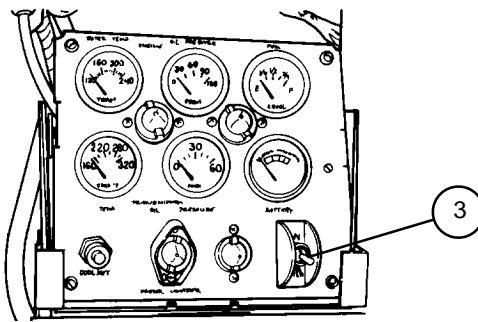
**NOTE**

If main accumulator nitrogen pressure is below 500 psi (3448 kPa), charge main accumulator (para 19-4).

- 9 Turn CAB POWER switch (4) and MASTER switch (3) to OFF.
- 10 Connect wire 645 (5) to pressure switch (6) or quick disconnect (7) near pressure switch.
- 11 Turn MASTER switch (3) and CAB POWER switch (4) to ON to charge hydraulic system.

**b. Service**

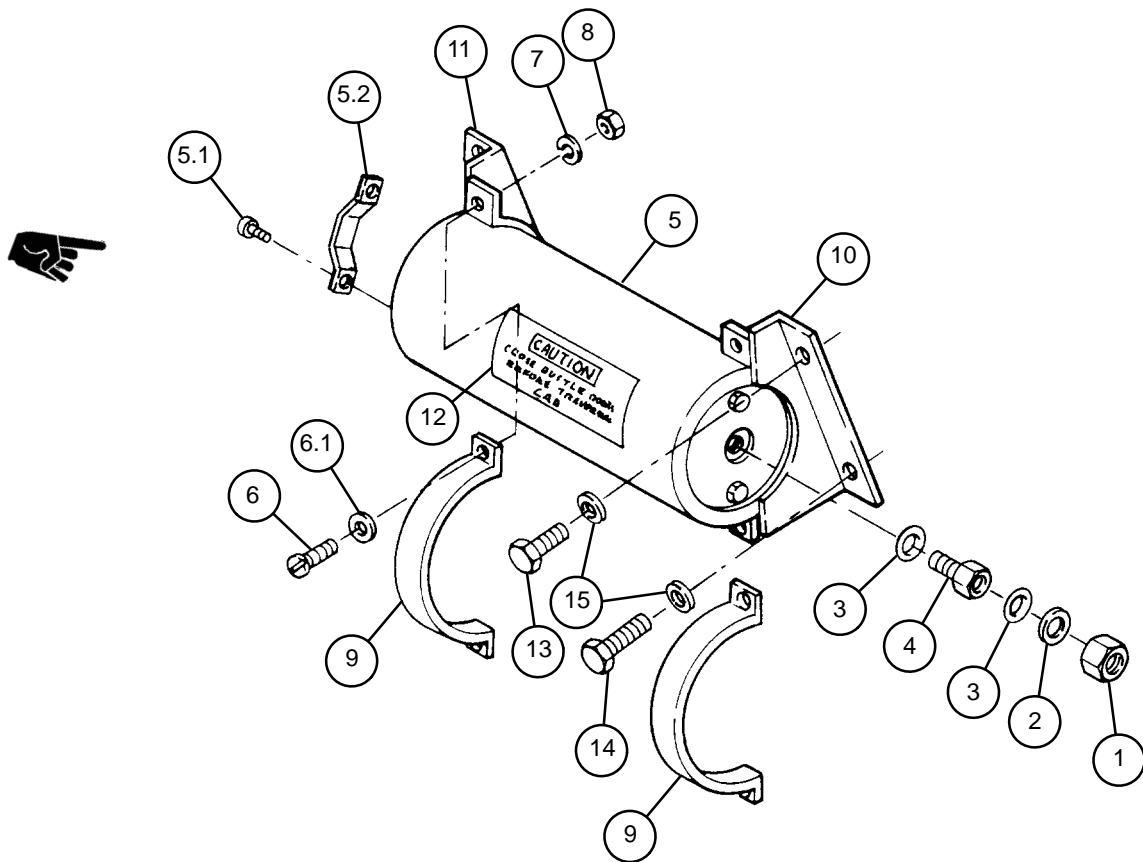
Service main accumulator assembly (para 19-4).





**d. Installation**

- 1 Install mounting brackets (10 and 11), four flat washers (15), two cap screws (14), and two cap screws (13).
- 2 If necessary for replacement, install identification marker (12) on primary accumulator (5) (para 2-7).
- 3 Position primary accumulator (5) in mounting brackets (10 and 11).
- 4 Install two retaining straps (9), four hex nuts (8), four new lockwashers (7), four flat washers (6.1) and four cap screws (6) to secure primary accumulator (5) on mounting brackets (10 and 11). Torque screws to 33-37 lb-ft (45-50 N·m).
- 5 Install retaining strap (5.2) and two screws (5.1) on end of primary accumulator (5).
- 6 Install bushing (4), two new preformed packings (3), flat washer (2) and new locknut (1) on primary accumulator (5).
- 7 Install tube tee at primary accumulator and install lines to tube tee (para 6-25).



## 6-12 ACCUMULATOR ASSEMBLY (SECONDARY)

This task covers:

a. Removal	b. Service
c. Test-Leakage	d. Installation

### INITIAL SETUP

Tools

Artillery and turret mechanic's tool kit  
(SC 5180-95-CL-A12)

Lockwashers (4) (item 55, Appx G)

Preformed packing (item 48, Appx G)

Materials/Parts

Caps and plugs (item 7, Appx D)

Equipment Condition

Discharge hydraulic pressure (para 6-3.1)

### a. Removal

#### CAUTION

All hydraulic lines and ports must be capped to prevent contaminants from entering the hydraulic system and causing internal damage to hydraulic components.

- 1 Remove hose connector (1), reducer (2), and preformed packing (3) from secondary accumulator assembly (4). Discard preformed packing.
- 2 Remove two machine screws (4.1) and mechanical guard (4.2) from secondary accumulator (4).
- 3 While supporting secondary accumulator (4), remove two cap screws (5), two flat washers (5.1), two lockwashers (6), two hex nuts (7), and retaining strap (8) from each accumulator bracket (9 and 10). Discard lockwashers.
- 4 Remove secondary accumulator (4).
- 5 If necessary to replacement, remove instruction plate (11) from secondary accumulator (4).
- 6 Remove four cap screws (12), four flat washers (13), and mounting brackets (9 and 10).

### b. Service

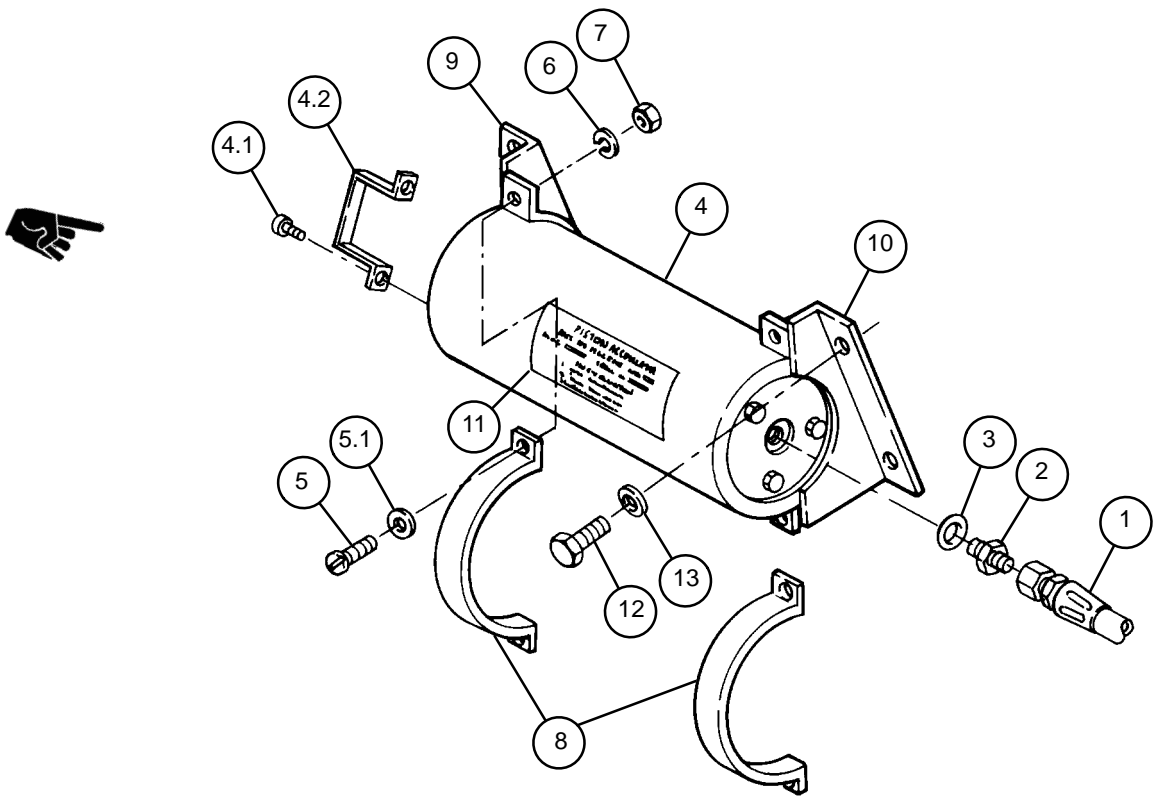
Service secondary accumulator assembly (para 19-6).

### c. Test-Leakage

- 1 Plug hydraulic tube hole in secondary accumulator (4).
- 2 Submerge secondary accumulator (4) completely in water for at least ten minutes. There must be no evidence of leakage during the entire period.
- 3 Replace secondary accumulator (4) if it leaks.

**d. Installation**

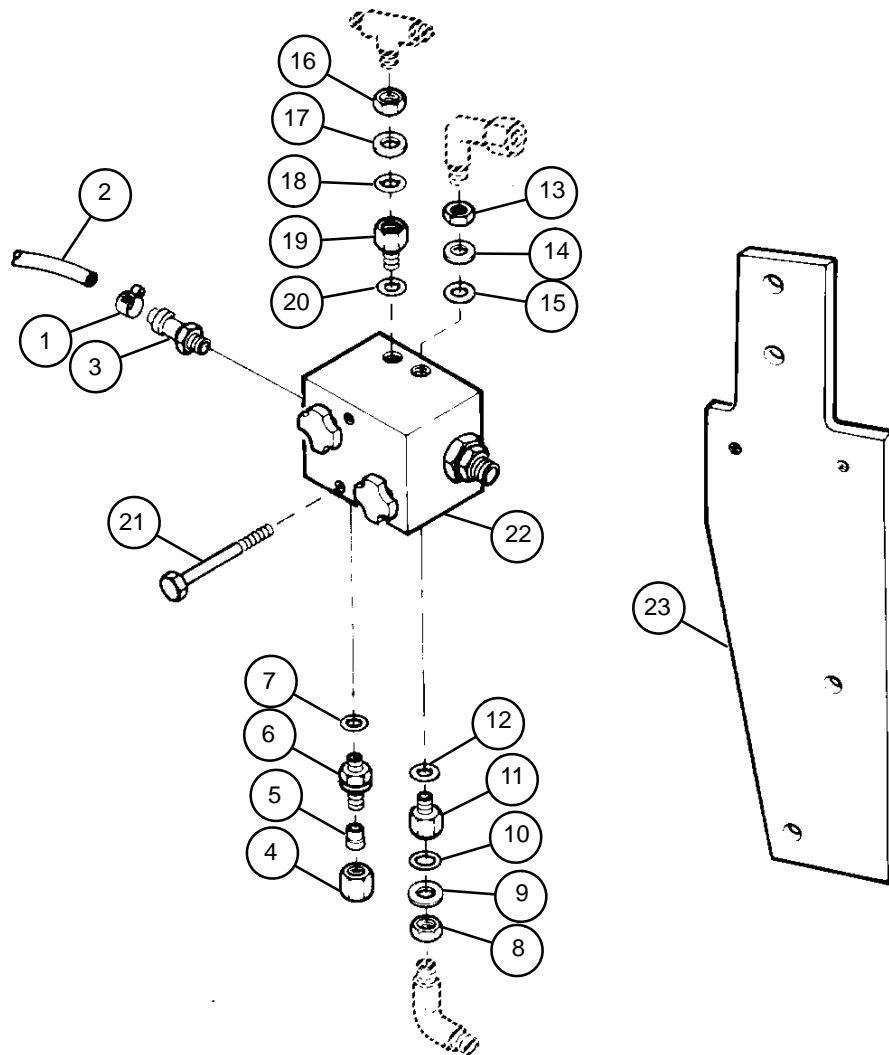
- 1 Install mounting brackets (9 and 10), four flat washers (13), and four cap screws (12).
- 2 If necessary for replacement, install instruction plate (11) on secondary accumulator (4) (para 2-7).
- 3 Position secondary accumulator (4) in accumulator brackets (9 and 10).
- 4 Secure secondary accumulator (4) to accumulator brackets (9 and 10) with two retaining straps (8), four hex nuts (7), four new lockwashers (6), four flat washers (5.1), and four cap screws (5). Torque screws to 33-37 lb-ft (45-50 N·m).
- 5 Install mechanical guard (4.2) and two machine screws (4.1) on secondary accumulator (4).
- 6 Install new preformed packing (3), reducer (2), and hose connector (1) to secondary accumulator (4).





**c. Installation**

- 1 Install manifold (22) to mounting plate (23) with two cap screws (21).
- 2 Install new preformed packing (20), reducer (19), new preformed packing (18), flat washer (17), and new locknut (16).
- 3 Install new preformed packing (15), packing retainer (14), and new locknut (13).
- 4 Install new preformed packing (12), reducer (11), new preformed packing (10), flat washer (9), and new locknut (8).
- 5 Install new preformed packing (7), check valve (6), clinch sleeve (5), and nut (4).
- 6 Install adapter (3), nonmetallic hose (2), and hose clamp (1).



## 6-14 EQUILIBRATION HANDPUMP ASSEMBLY

- This task covers:
- |                 |                |
|-----------------|----------------|
| a. Removal      | b. Disassembly |
| c. Inspection   | d. Assembly    |
| e. Installation |                |

### INITIAL SETUP

Tools

Artillery and turret mechanic's tool kit  
(SC 5180-95-CL-A12)

Materials/Parts

Caps and plugs (item 7, Appx D)  
Hydraulic fluid, OHT (item 21, Appx D)  
Lockwashers (2) (item 55, Appx G)

Lockwashers (2) (item 56.1, Appx G)  
Preformed packing (item 46, Appx G)  
Preformed packing (item 47, Appx G)  
Self-locking nut (item 29, Appx G)

Equipment Condition

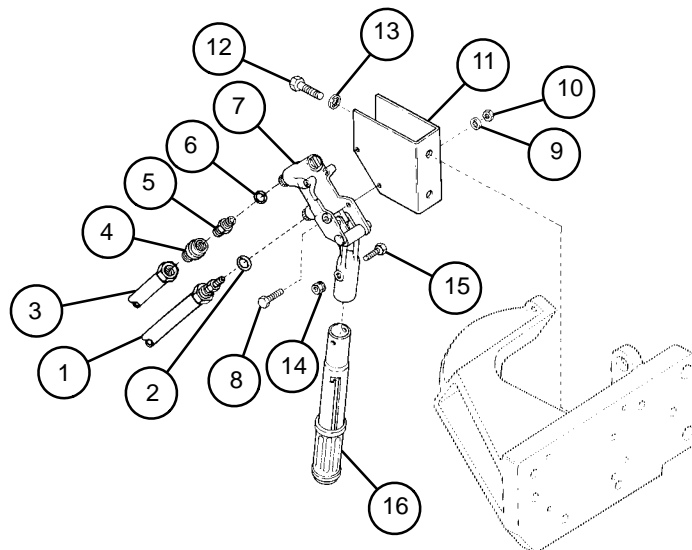
Discharge hydraulic pressure (para 6-3.1)  
Bleed hydraulic system (para 6-3.1)

#### a. Removal

### CAUTION

All hydraulic lines and ports must be capped to prevent contaminants from entering the hydraulic system and causing internal damage to hydraulic components.

- 1 Remove adapter (1), preformed packing (2), coupling nut (3), clinch sleeve (4), reducer (5), and preformed packing (6) at hydraulic pump (7). Discard preformed packings.
- 2 Remove two cap screws (8), two lockwashers (9), and two hex nuts (10) from mounting bracket (11). Discard lockwashers.
- 3 Remove hydraulic pump (7).
- 4 Remove two cap screws (12), two lockwashers (13), and mounting bracket (11).





**b. Disassembly**

- 1 Remove self-locking nut (14) and machine screw (15). Discard self-locking nut.
- 2 Separate handle (16) from hydraulic pump (7).

**c. Inspection**

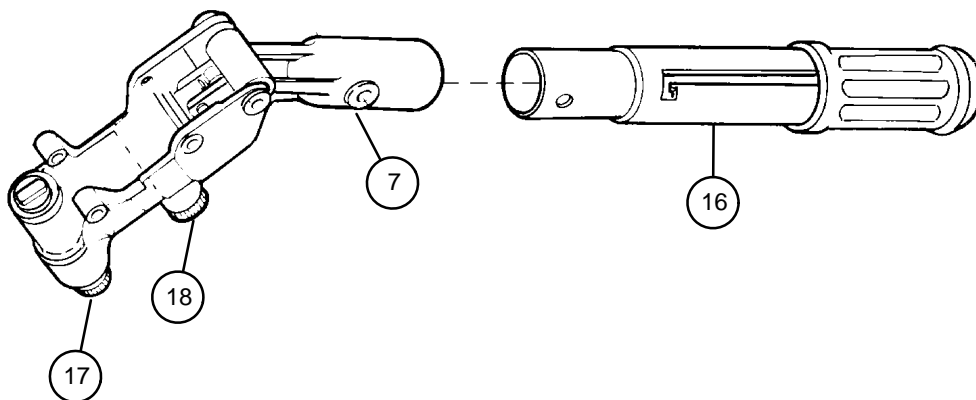
- 1 Inspect handle (16). Replace if cracked, distorted, or damaged.
- 2 Inspect hydraulic pump (7). Replace if not operable, or if threads to suction port (17) or pressure port (18) are damaged.

**d. Assembly**

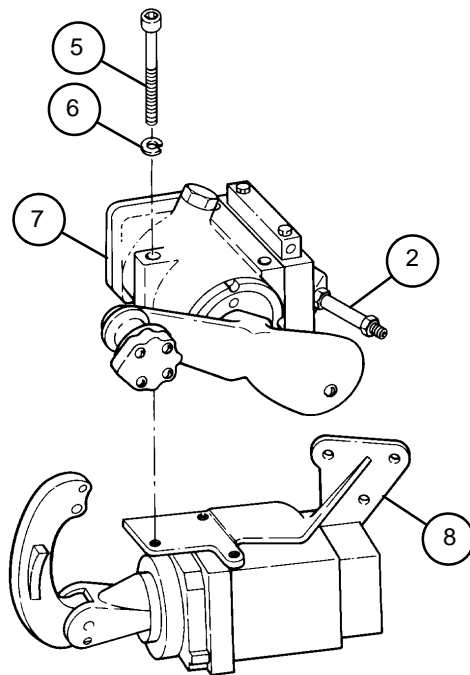
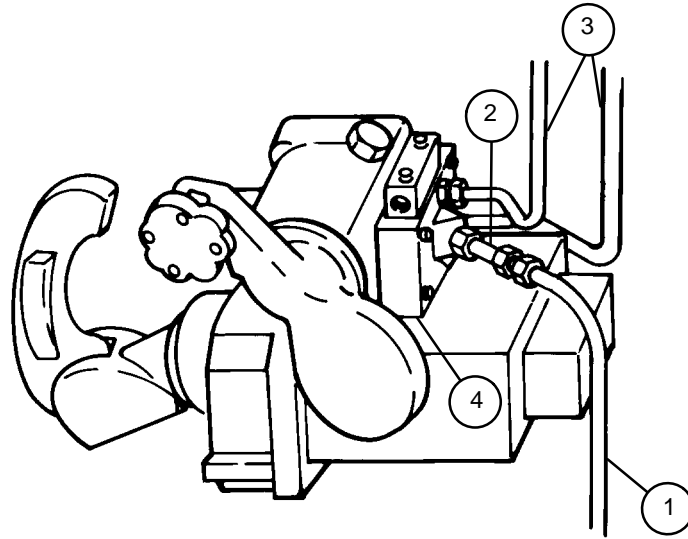
- 1 Insert handle (16) into hydraulic pump (7) aligning holes for machine screw (15).
- 2 Install machine screw (15) and new self-locking nut (14) to secure handle (16) to hydraulic pump (7).

**e. Installation**

- 1 Install two cap screws (12), two new lockwashers (13), and mounting bracket (11). ■
- 2 Secure hydraulic pump (7) to mounting bracket (11) with two cap screws (8), two new lockwashers (9), and two hex nuts (10).
- 3 Install new preformed packing (6), reducer (5), clinch sleeve (4), coupling nut (3), new preformed packing (2), and adapter (1).



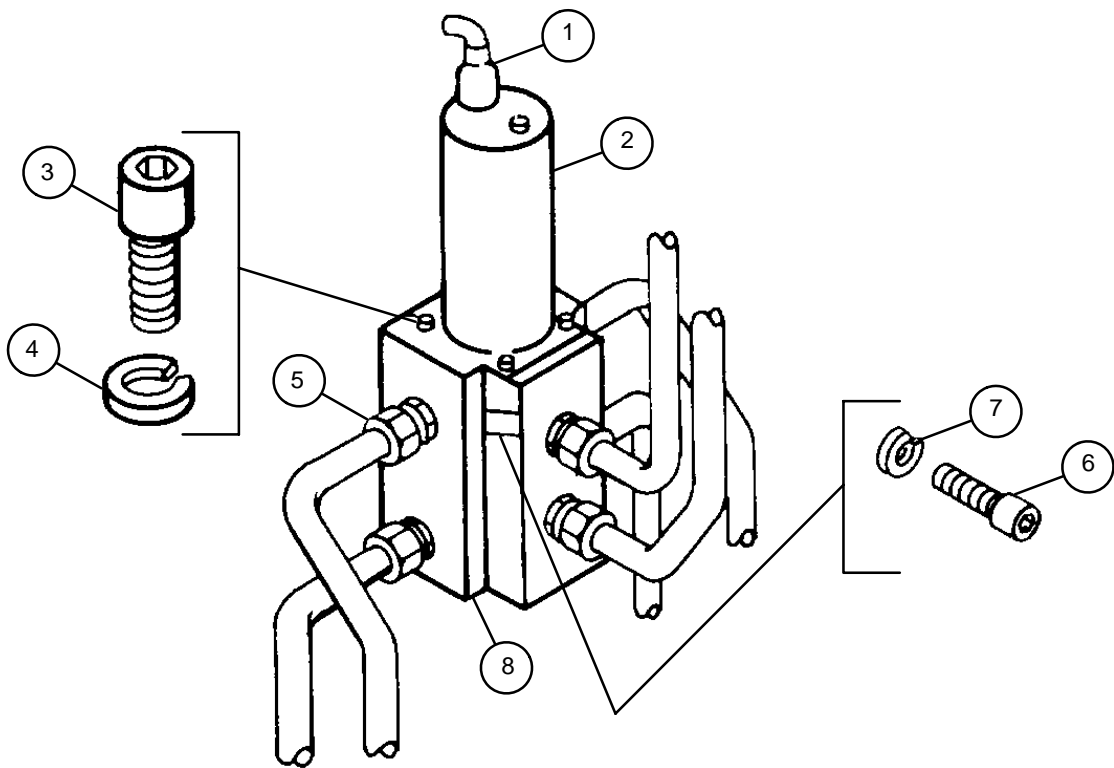






**b. Installation**

- 1 Install two new lockwashers (7) and two cap screws (6) in plate (not shown) and body assembly (8).
- 2 Connect six hydraulic tube connectors (5).
- 3 Install solenoid (2) and secure with four new lockwashers (4) and four cap screws (3).
- 4 Connect electrical connector (1) at top of solenoid (2).



---

## 6-17 HYDRAULIC FILTER ASSEMBLY

---

- This task covers:
- |                 |                |
|-----------------|----------------|
| a. Removal      | b. Disassembly |
| c. Inspection   | d. Assembly    |
| e. Installation |                |
- 

### **INITIAL SETUP**

Applicable Configuration  
M109A4/M109A5 howitzers

Tools  
Artillery and turret mechanic's tool kit  
(SC 5180-95-CL-A12)

Drain pan (item 8, Appx H)

Materials/Parts  
Cap and plug set (item 7, Appx D)

Hydraulic filter parts kit (item 187, Appx G)  
Lockwashers (8) (item 79, Appx G)  
Preformed packings (4) (item 44, Appx G)

Equipment Condition  
Discharge hydraulic pressure (para 6-3)

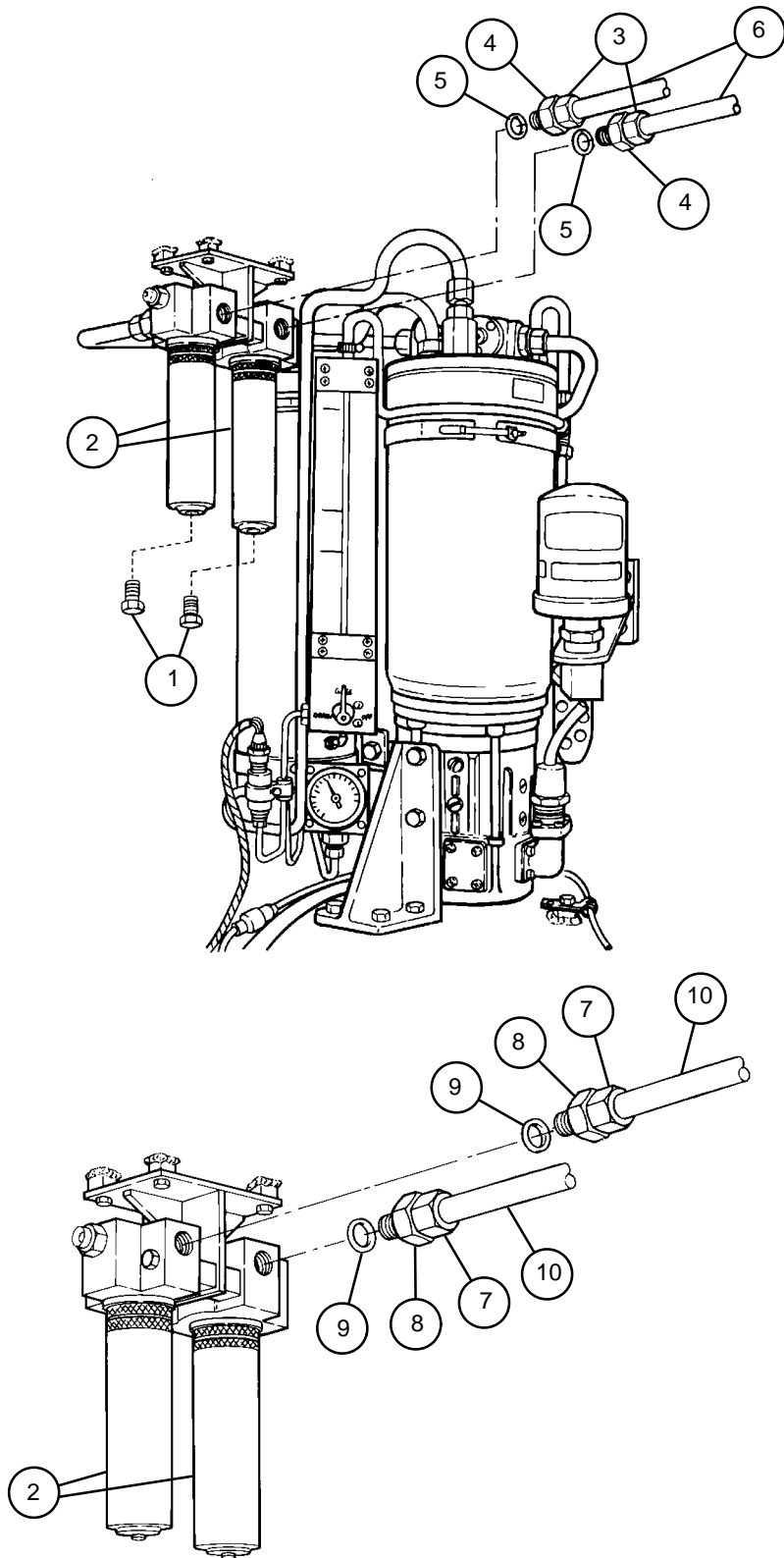
---

### **a. Removal**

#### **NOTE**

- If replacing filter assemblies only, proceed to step 2.
- Dispose of hydraulic fluid in accordance with local regulations.

- 1 Remove drain plugs (1) (if present) from filter assemblies (2) and drain hydraulic fluid from bottom of filter assemblies into drain pan. Replace drain plugs.
- 2 Loosen two nuts (3) and disconnect two adapters (4), two preformed packings (5), and attaching tubes (6) from filter assemblies (2) and drain into drain pan. Discard preformed packings.
- 3 Loosen two nuts (7) and disconnect two adapters (8), two preformed packings (9), and attaching tubes (10) from back of filter assemblies (2). Discard preformed packings. Drain excess hydraulic fluid into drain pan.

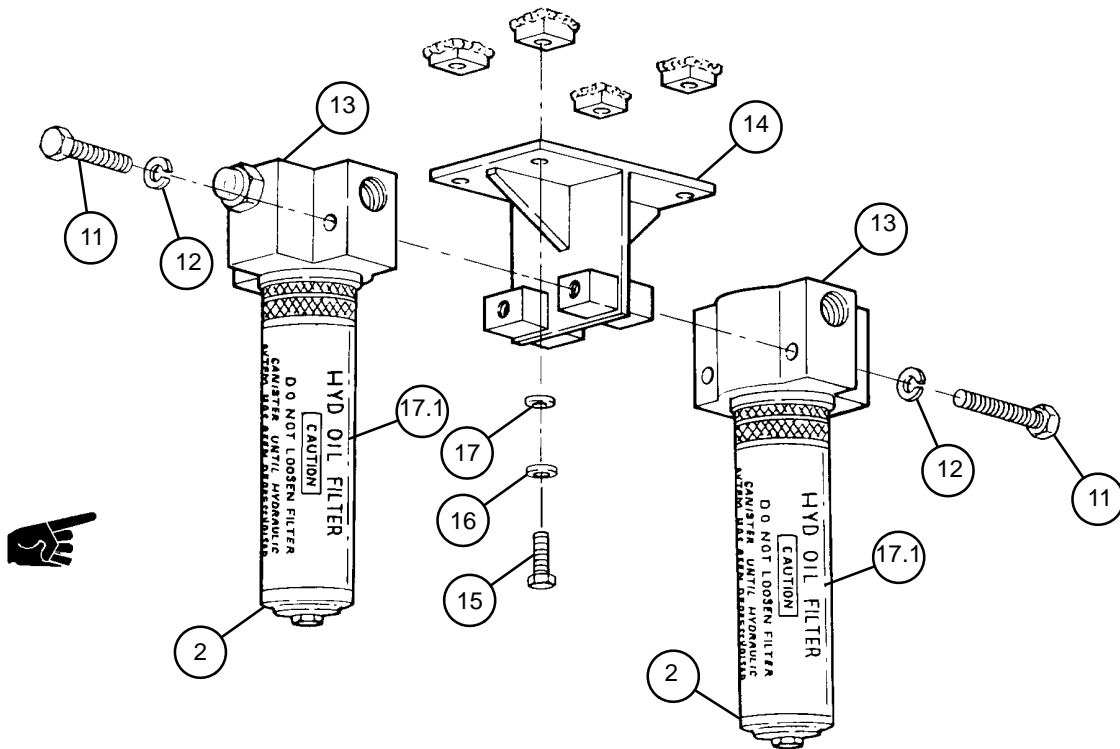


BACK VIEW

## 6-17 HYDRAULIC FILTER ASSEMBLY — CONTINUED

### a. Removal — Continued

- 4 Remove four cap screws (11) and four lockwashers (12) from manifold (13) and remove two filter assemblies (2) from mounting bracket (14). Drain excess hydraulic fluid from manifold. Discard lockwashers.
- 5 If mounting bracket (14) for filter assemblies (2) is damaged, remove four cap screws (15), four lockwashers (16), four flat washers (17), and replace mounting bracket. Discard lockwashers.
- 6 If necessary for replacement, remove identification marker (17.1).



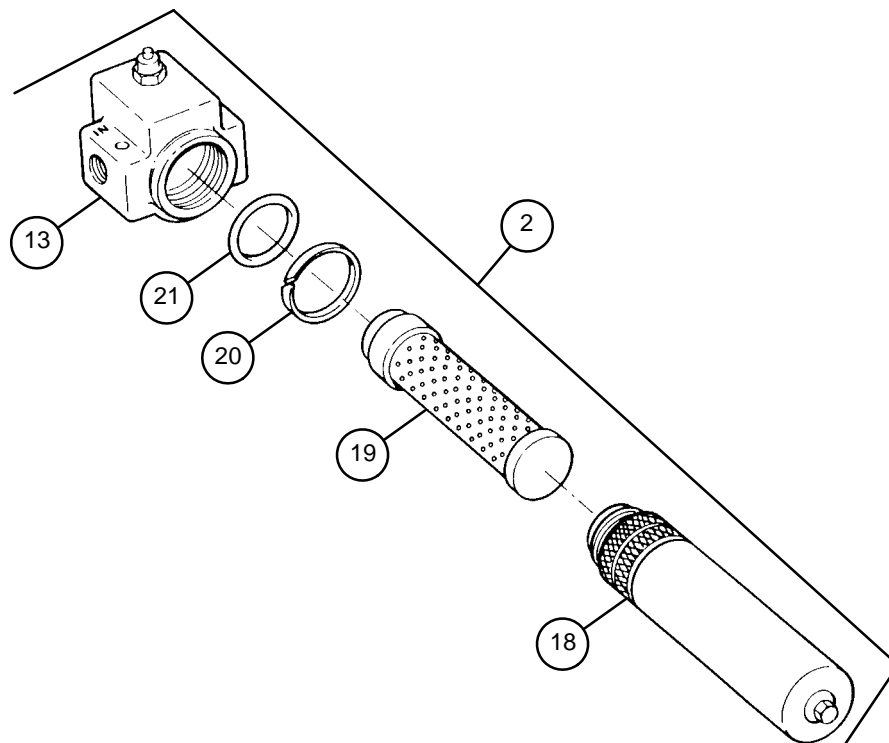


**b. Disassembly****NOTE**

- Filter assemblies do not have to be removed to replace filter elements. However, hydraulic system must be discharged (para 6-3) and filter assemblies drained before filter elements are removed.
- Both filter elements are normally replaced at the same time.
- There are three approved manufacturers for the filter assembly. The filter element is the only part interchangeable between all the manufacturers. Identify the manufacturer to perform the correct steps.

1 To disassemble Pall Land and Marine Corporation filter assembly (2):

- (a) Unscrew filter housing (18) from manifold (13).
- (b) Remove and discard filter element (19) and residual fluid.
- (c) Remove preformed packing (20) and packing retainer (21) from manifold (13). Discard preformed packing and packing retainer.



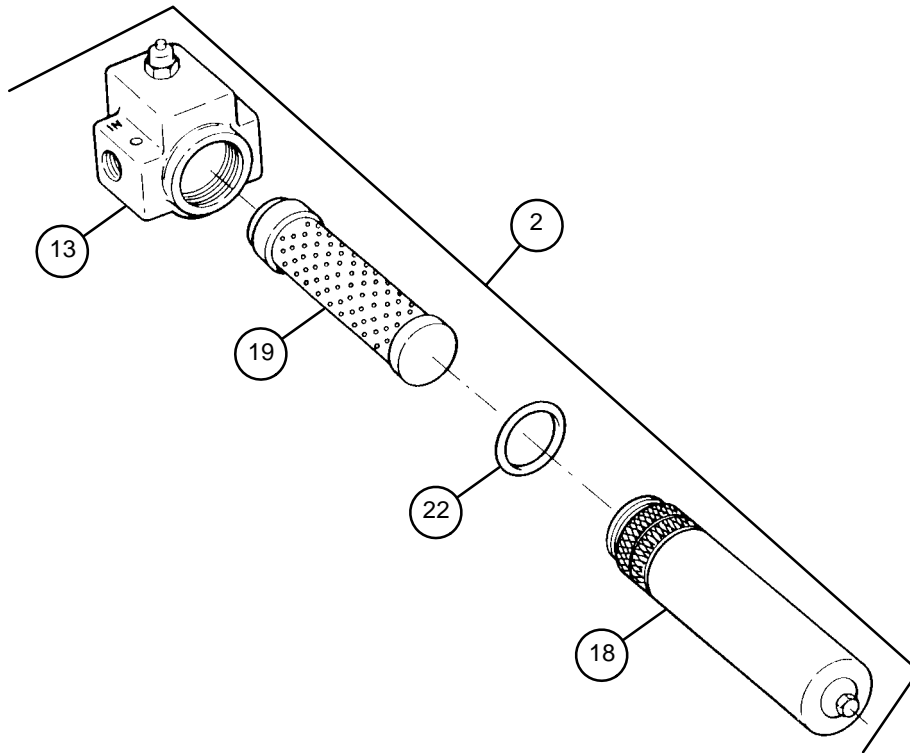
---

## 6-17 HYDRAULIC FILTER ASSEMBLY — CONTINUED

---

### b. Disassembly — Continued

- 2 To disassemble Parker Hannifin Corporation filter assembly (2):
  - (a) Unscrew filter housing (18) from manifold (13).
  - (b) Remove and discard filter element (19) and residual fluid.
  - (c) Remove preformed packing (22) from the top of the filter housing (18). Discard preformed packing.



- 3 To disassemble Diagnostics Corporation filter assembly (2):
  - (a) Unscrew filter housing (18) from manifold (13).

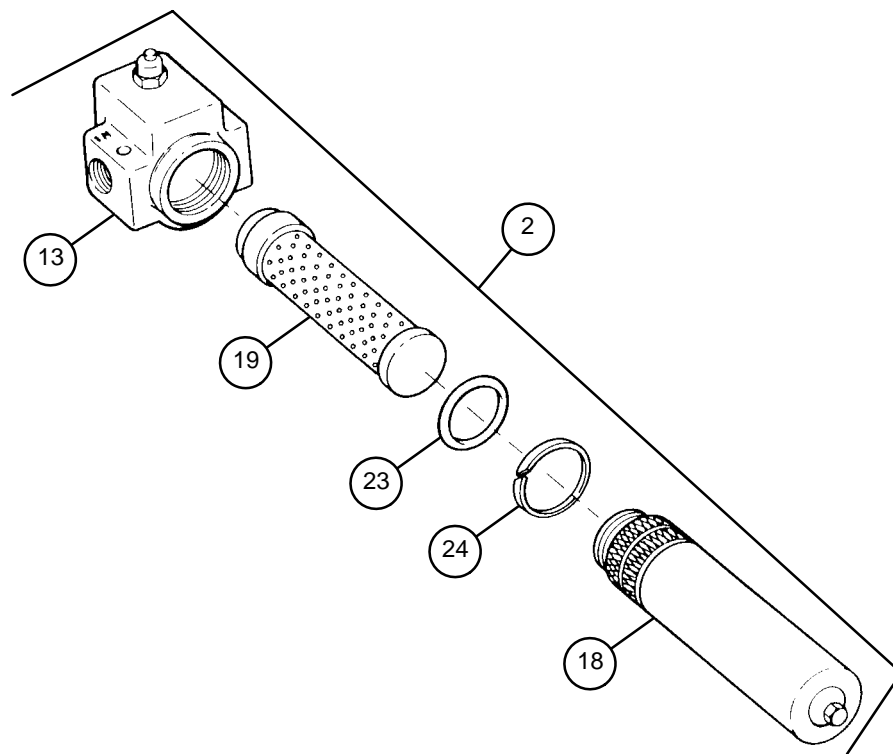
**NOTE**

A spring sits under the filter element. If spring falls out, retain for assembly.

- (b) Remove and discard filter element (19) and residual fluid.
- (c) Remove preformed packing (23) and packing retainer (24) from filter housing (18). Discard preformed packing and packing retainer.

**c. Inspection**

Inspect filter housing (18) and manifold (13) for cracks or distortions. Replace filter assembly (2) if filter housing or manifold is damaged.



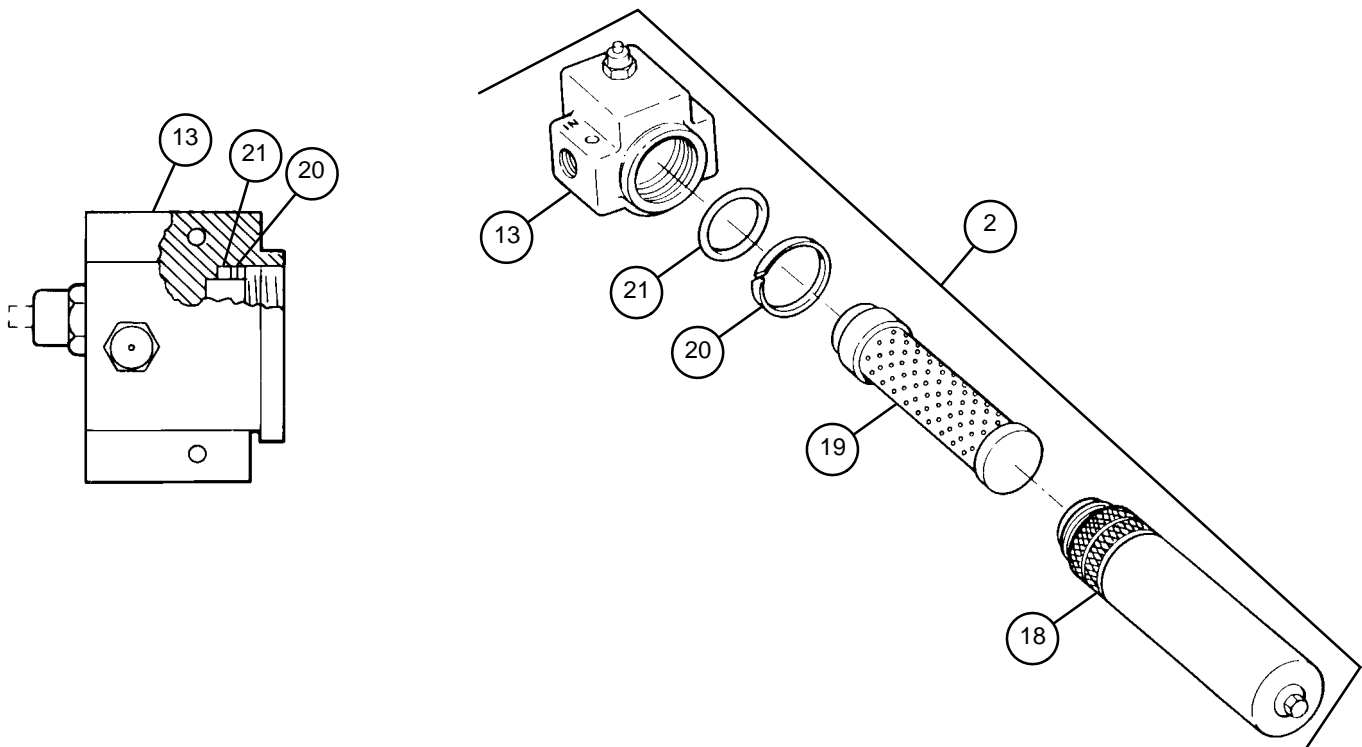
## 6-17 HYDRAULIC FILTER ASSEMBLY — CONTINUED

### d. Assembly

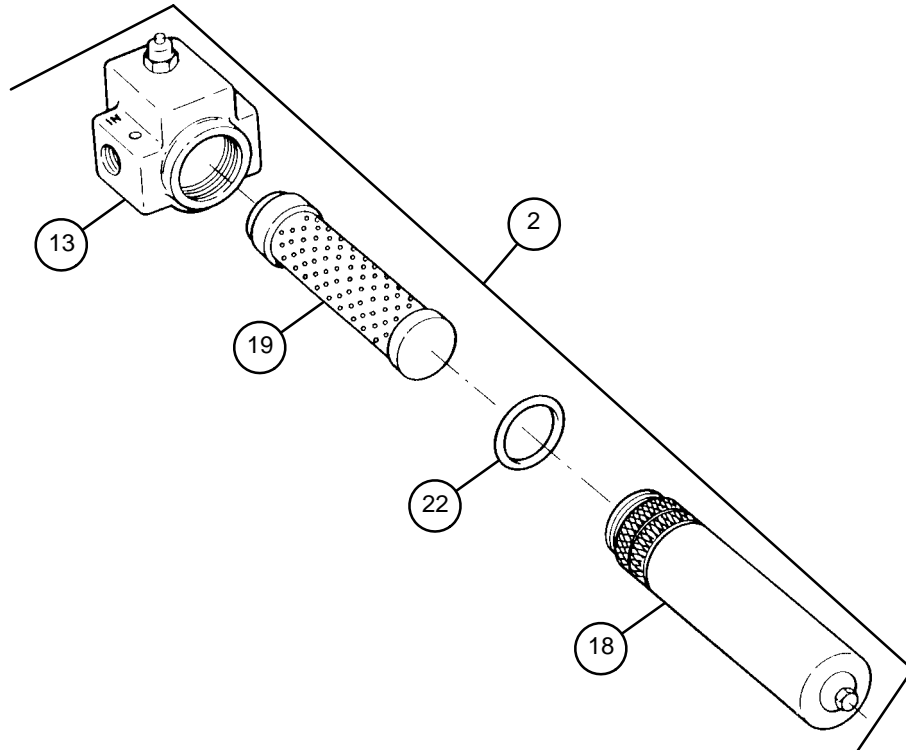
#### NOTE

- There are three approved manufacturers for the filter assembly. The filter element is the only part interchangeable between all the manufacturers. Identify the manufacturer to perform the correct steps.
- Lubricate new preformed packings and packing retainers with hydraulic fluid.

- 1 To assemble Pall Land and Marine Corporation filter assembly (2):
  - (a) Install new preformed packing (21) and new packing retainer (20) into groove of manifold (13). Ensure the cut ends of packing retainer overlap smoothly and do not protrude out of the groove.
  - (b) Install new filter element (19) into the filter housing (18) ensuring the hole of the filter element is visible.
  - (c) Screw filter housing (18) into manifold (13) until firmly seated.



- 2 To assemble Parker Hannifin Corporation filter assembly (2):
  - (a) Install preformed packing (22) into groove on the top of filter housing (18).
  - (b) Install new filter element (19) into the filter housing (18) ensuring the hole of the filter element is visible.
  - (c) Screw filter housing (18) into manifold (13) until firmly seated.



## 6-17 HYDRAULIC FILTER ASSEMBLY — CONTINUED

### d. Assembly — Continued

- 3 To assemble Diagnostics Corporation filter assembly (2):
  - (a) Install new packing retainer (24) and new preformed packing (23) into groove on the top of filter housing (18). Ensure the cut ends of packing retainer overlap smoothly and do not protrude out of the groove.

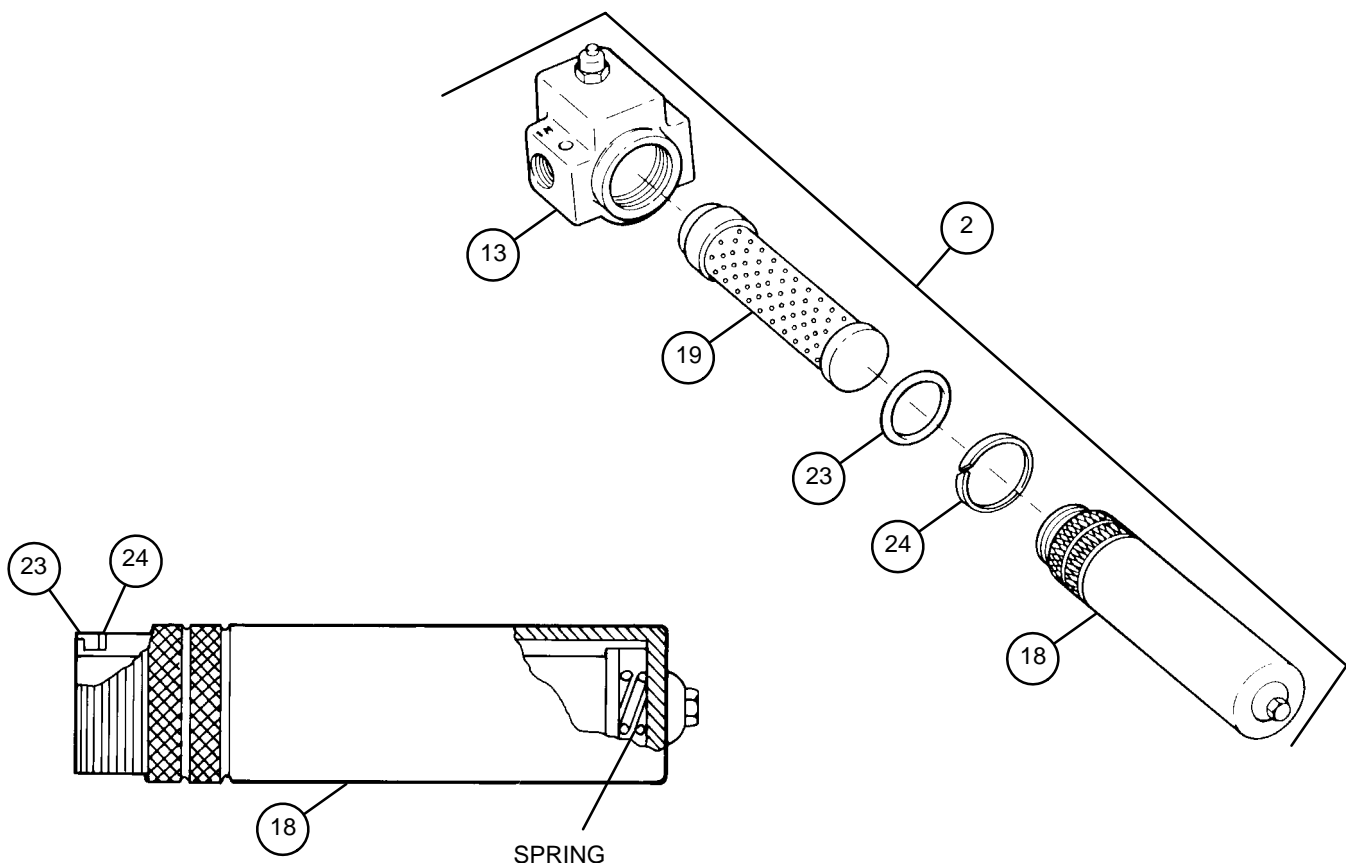
#### NOTE

Ensure spring is placed in bottom of bowl with axis parallel to bowl centerline.

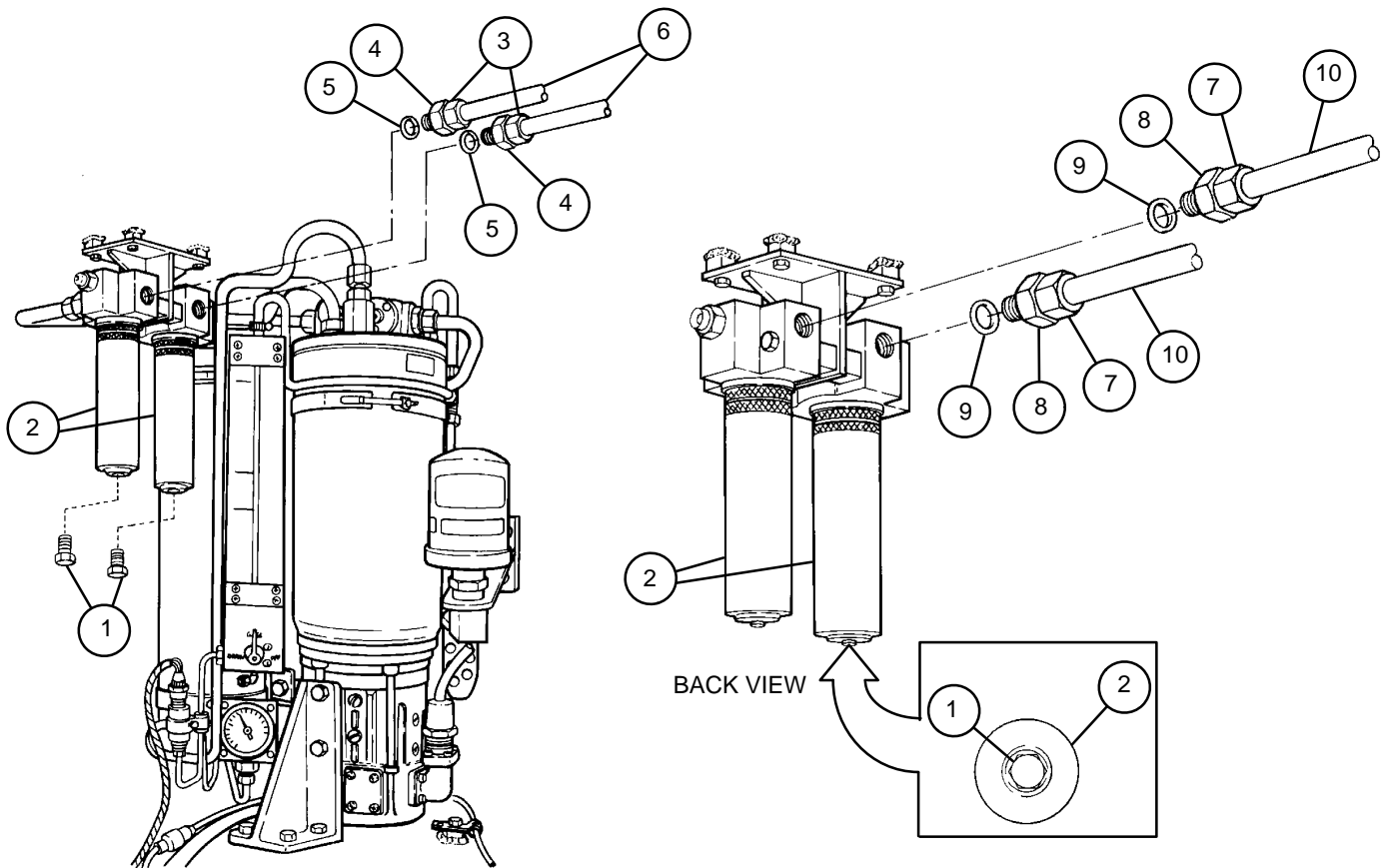
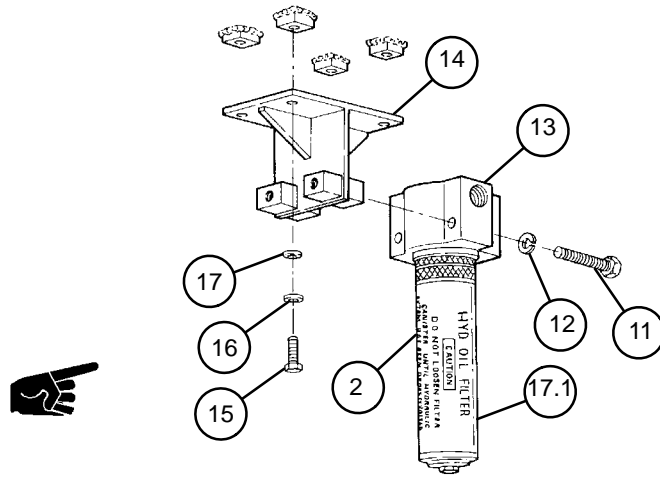
- (b) Install new filter element (19) into the filter housing (18) ensuring the hole of the filter element is visible.
- (c) Screw filter housing (18) into manifold (13) until firmly seated.

### e. Installation

- 1 If mounting bracket (14) was removed, position mounting bracket on cab ceiling. Install and hand tighten four flat washers (17), four new lockwashers (16), and four cap screws (15).
- 2 If necessary for replacement, install identification marker (17.1) (para 2-7).
- 3 Mount two filter assemblies (2) to mounting bracket (14) using four new lockwashers (12) and four cap screws (11).



- 4 If removed, install drain plugs (1) in bottom of filter assemblies (2).
- 5 Install two new preformed packings (9) and connect two adapters (8) and attaching tubes (10) to back of two filter assemblies (2). Tighten two nuts (7).
- 6 Install two new preformed packings (5) and connect two adapters (4) with attaching tubes (6) to filter assemblies (2). Tighten two nuts (3).
- 7 Tighten four cap screws (15) holding mounting bracket (14).







- 3 Screw nipple (4) into side hole of air line filter (3) and attach to fitting (5).
- 4 Install new preformed packing (8) and hygroscopic breather (6) or hygroscopic breather (6.1) on fitting (5).
- 5 Install adapter (1) with attaching tube (2) to air line filter (3).
- 6 After installation, check hydraulic fluid level (para 6-2).

**c. Service**

**NOTE**

- This procedure applies only to the hygroscopic breather. The hygroscopic breather has a clear plastic container which may be removed from the breather base for service.
- Perform service procedures to replace the desiccant when the desiccant turns pink.

- 1 Remove hygroscopic breather (12) from breather base (13).

**CAUTION**

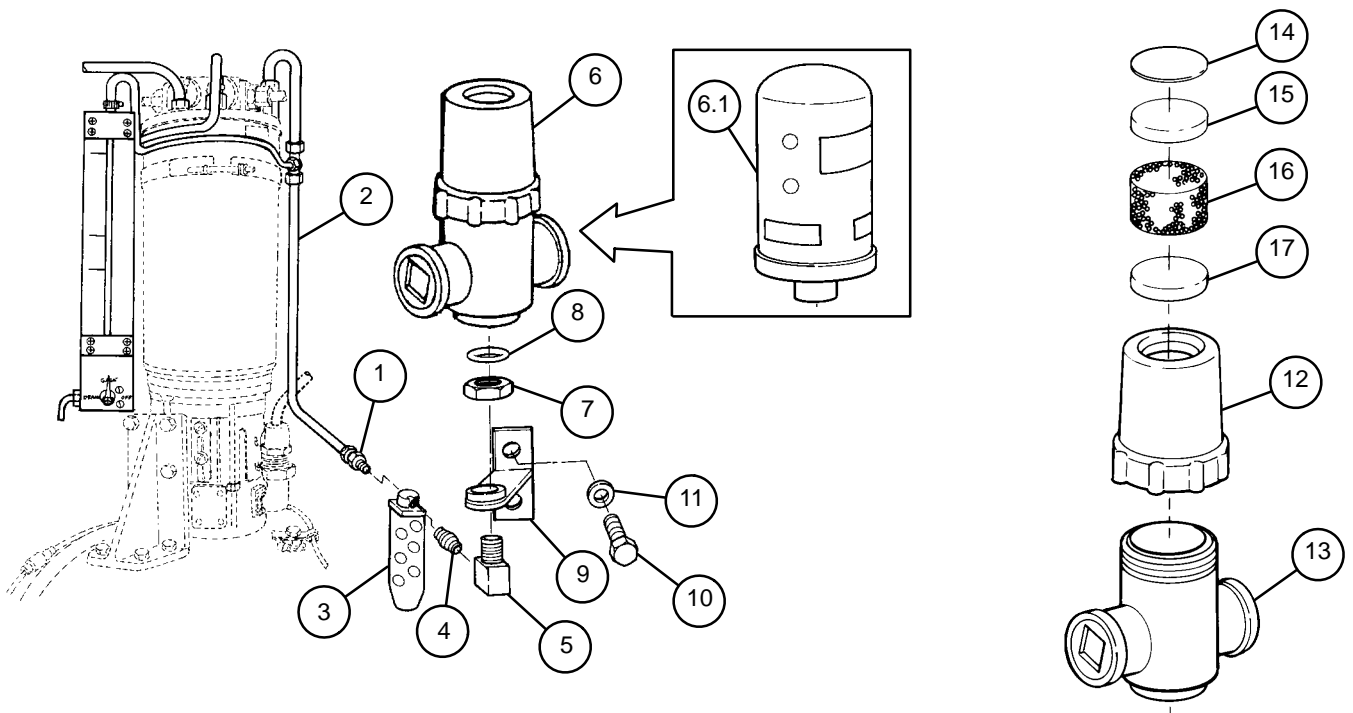
Be careful not to damage or stretch inlet flapper during removal.

- 2 Remove inlet flapper (14), foam (15), dessicant (16), and foam (17).
- 3 Using a clean dry rag, wipe away any residual moisture from hygroscopic breather (12), inlet flapper (14), and foam (15 and 17).

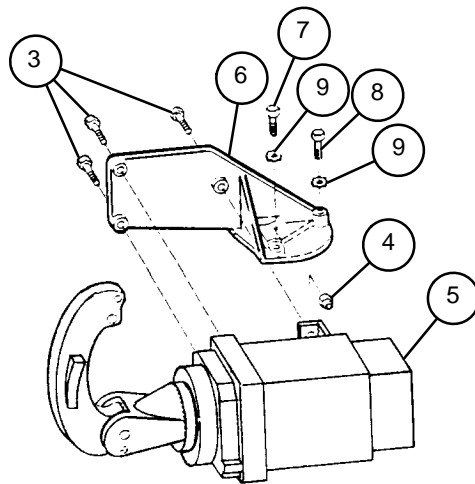
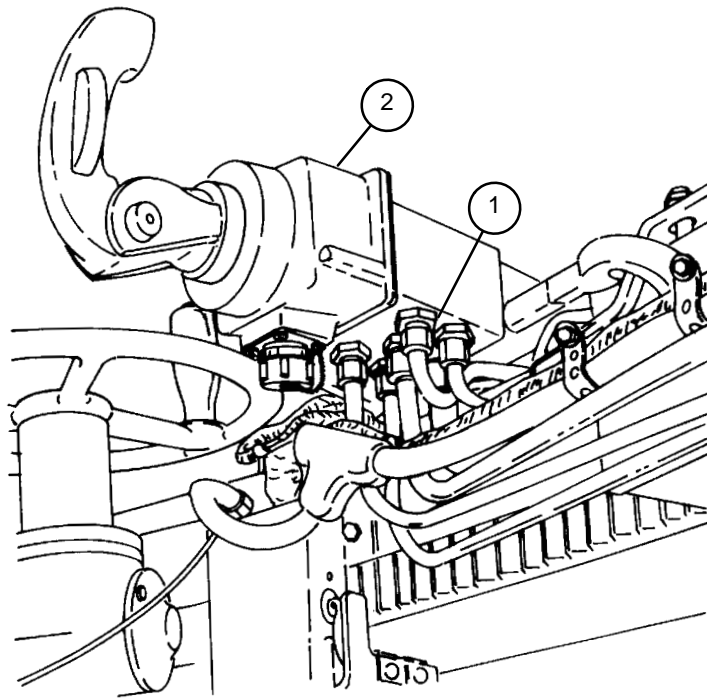
**CAUTION**

Be careful not to damage or stretch inlet flapper during installation.

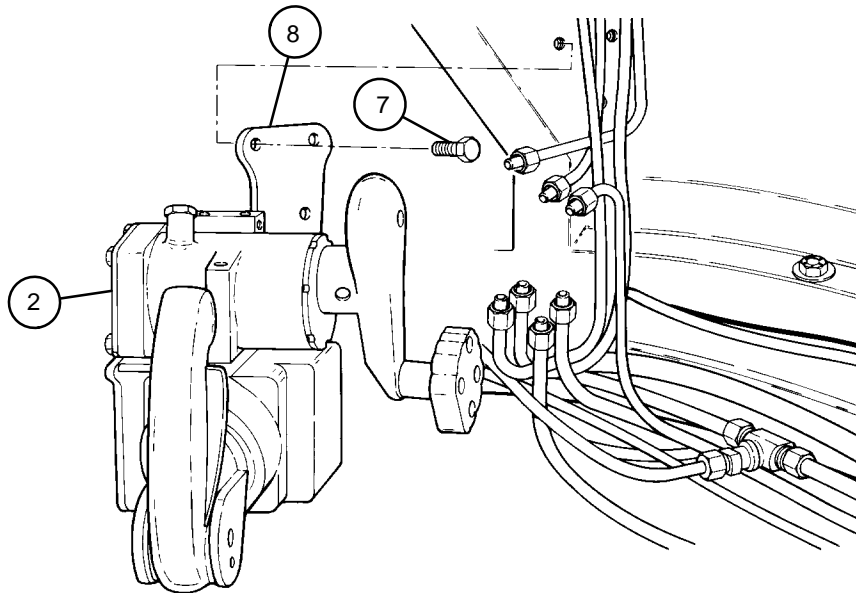
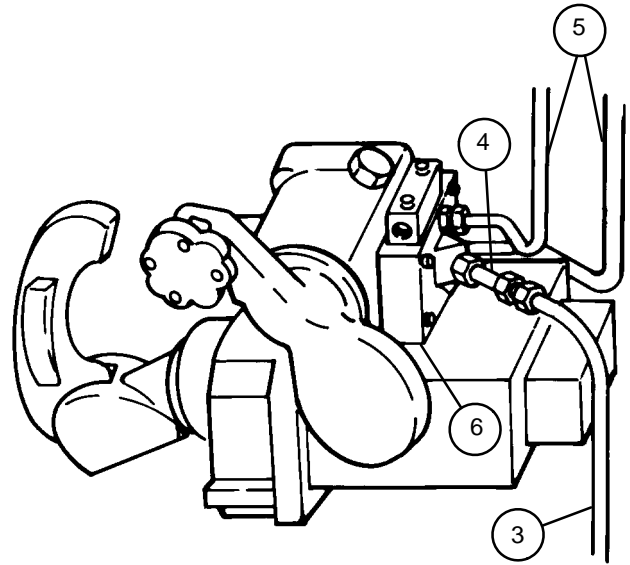
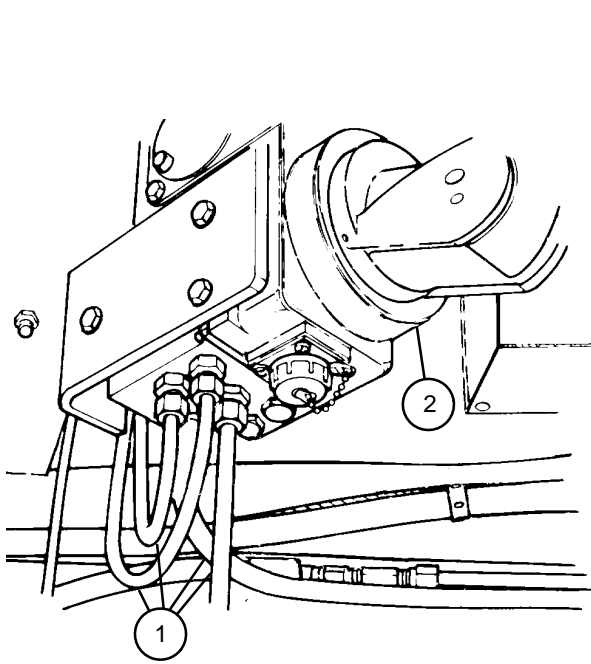
- 4 Install foam (17), new dessicant (16), foam (17), and inlet flapper (14).
- 5 Install hygroscopic breather (12) to breather base (13).











---

## 6–21 GUNNER’S/ASSISTANT GUNNER’S CONTROL ASSEMBLY HANDLES

---

This task covers: a. Removal b. Installation

---

### **INITIAL SETUP**

#### Tools

Artillery and turret mechanic’s tool kit  
(SC 5180–95–CL–A12)

#### Materials/Parts

Sealing compound (item 27, Appx D)

#### Equipment Condition

Gunner’s control assembly removed (para 6–19)  
Assistant gunner’s control assembly removed (para 6–20)

---

### **NOTE**

- Some handles may have the gunner’s control lead assembly in place during removal. They are not to be reassembled during the installation procedure.
- Use identical service procedures for both the left and right handle assemblies.

#### **a. Removal**

- 1 Remove shoulder screw (1) from handle (2) through access hole in bracket and housing group (3).
- 2 Remove setscrew (4) and straight shaft (5) from bracket and housing group (3).
- 3 Remove handle (2) from bracket and housing group (3).

### **NOTE**

Retain shims unless new components are to be installed.

- 4 Remove shims (6) from bracket and housing group (3).

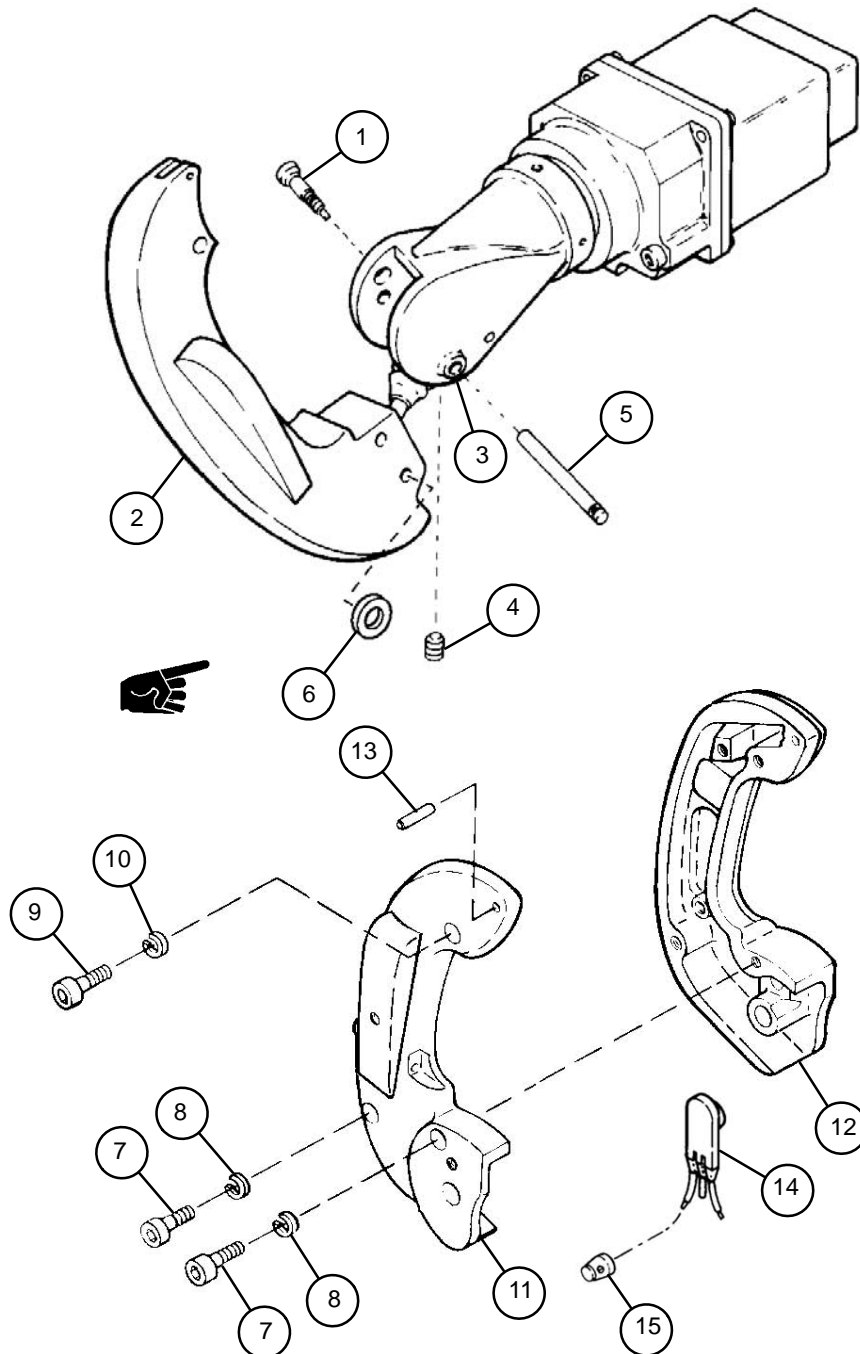
### **NOTE**

If gunner’s control lead assembly is connected to the gunner’s control assembly handle, go to step 5.

- 5 Remove two cap screws (7) and two lockwashers (8).
- 6 Remove cap screw (9) and lockwasher (10).
- 7 Separate left and right handle halves (11 and 12).
- 8 Drive out headless straight pin (13).
- 9 Disconnect gunner’s control lead assembly (14) from setscrews (15).

**b. Installation**

- 1 Install handle (2) in bracket and housing group (3).
- 2 Install shims (6) between handle (2) and housing assembly (3). Shim as required up to a maximum of ten shims to obtain 0.003 to 0.008 inch (0.08 to 0.2 mm) total end play.
- 3 Install straight shaft (5) and setscrew (4) in bracket and housing group (3).
- 4 Apply sealing compound to threads of shoulder screw (1) and install shoulder screw in handle (2) through access hole in bracket and housing group (3).







**NOTE**

- All hydraulic lines and components must be tagged before removal for identification during installation.
- The removal of hydraulic tubes and fittings must be restricted to those items that are to be replaced. Therefore, the legends in this chapter are for identification only.

For removal, follow illustration and legend as a guide. Discard all lockwashers and preformed packings.

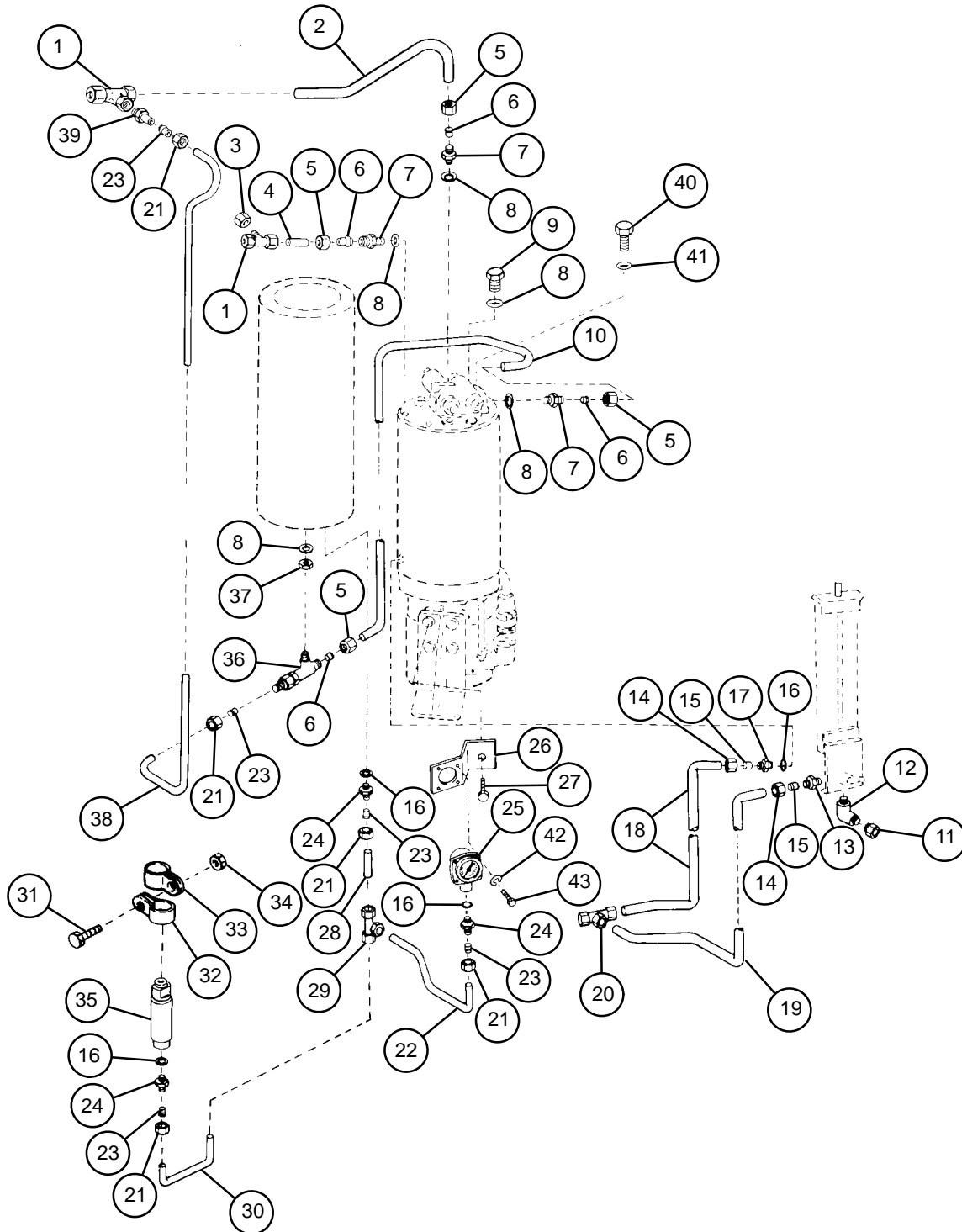
**b. Installation****CAUTION**

When installing any hydraulic fitting, tighten fitting to align with the connecting lines. Repositioning can loosen threads, cause leaks, and damage preformed packings.

For installation, follow illustration and legend as a guide. After installation, check hydraulic fluid level (para 6-2).

## 6-22 LINES AND FITTINGS FROM POWER PACK TO PRESSURE SWITCH AND GAGES — CONTINUED

Follow illustration as a guide for M109A2/M109A3 howitzers.

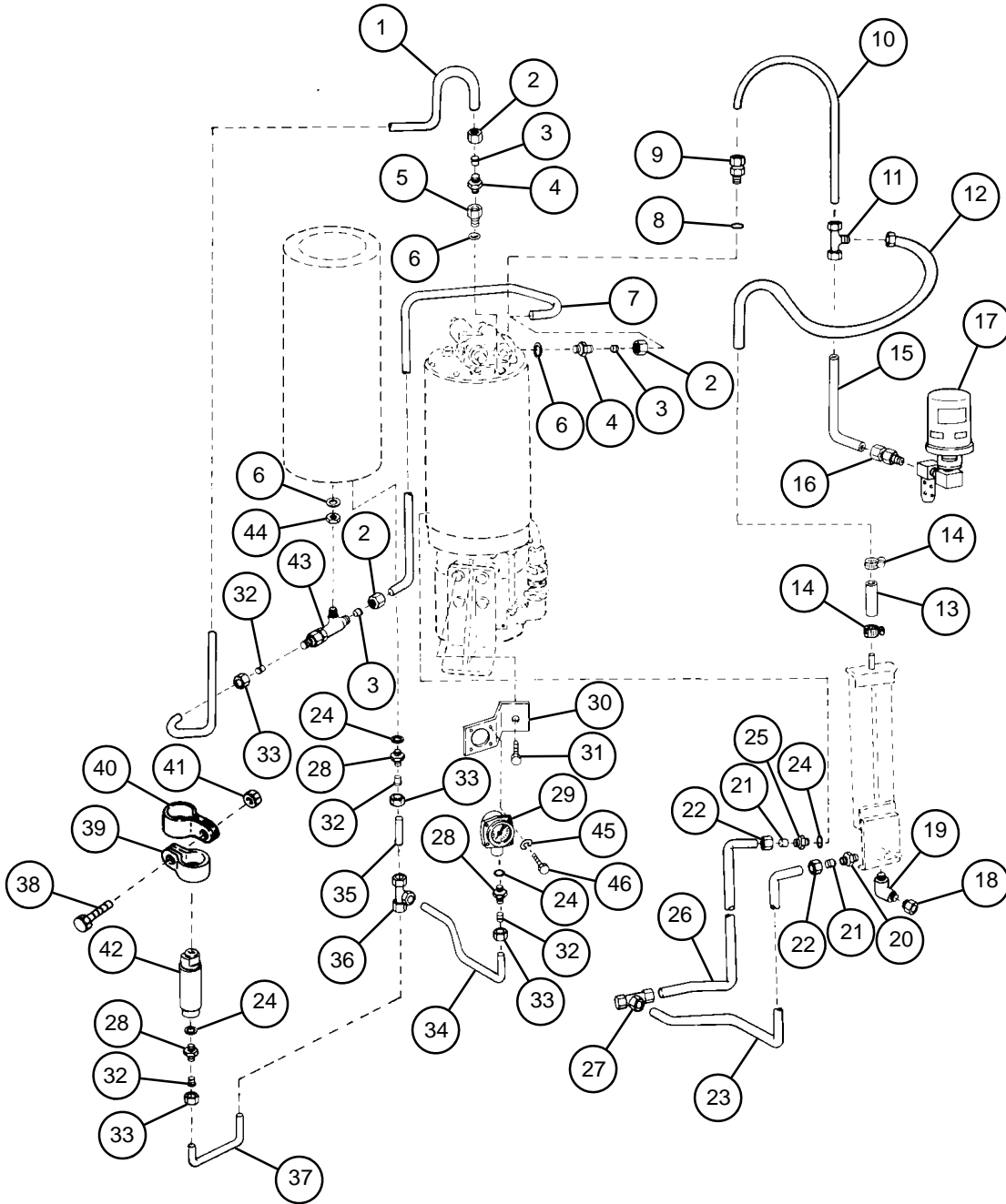


## LEGEND:

1. Tee (2)
2. Bent metallic tube
3. Cap
4. Tube coupling
5. Nut (4)
6. Clinch sleeve (4)
7. Reducer (3)
8. Preformed packing (5)
9. Plug
10. Bent metallic tube
11. Cap
12. Elbow
13. Adapter
14. Nut (2)
15. Clinch sleeve (2)
16. Preformed packing (4)
17. Adapter
18. Bent metallic tube
19. Bent metallic tube
20. Tee
21. Nut (5)
22. Tube
23. Clinch sleeve (5)
24. Reducer (3)
25. Pressure gage
26. Mounting bracket
27. Screw
28. Coupling
29. Tee
30. Bent metallic tube
31. Machine bolt
32. Loop clamp
33. Loop clamp
34. Hex nut
35. Pressure switch
36. Safety relief valve
37. Hex nut
38. Bent metallic tube
39. Reducer
40. Plug
41. Preformed packing
42. Lockwasher (4)
43. Machine screw (4)

## 6-22 LINES AND FITTINGS FROM POWER PACK TO PRESSURE SWITCH AND GAGES — CONTINUED

Follow illustration as a guide for M109A4/M109A5 howitzers.

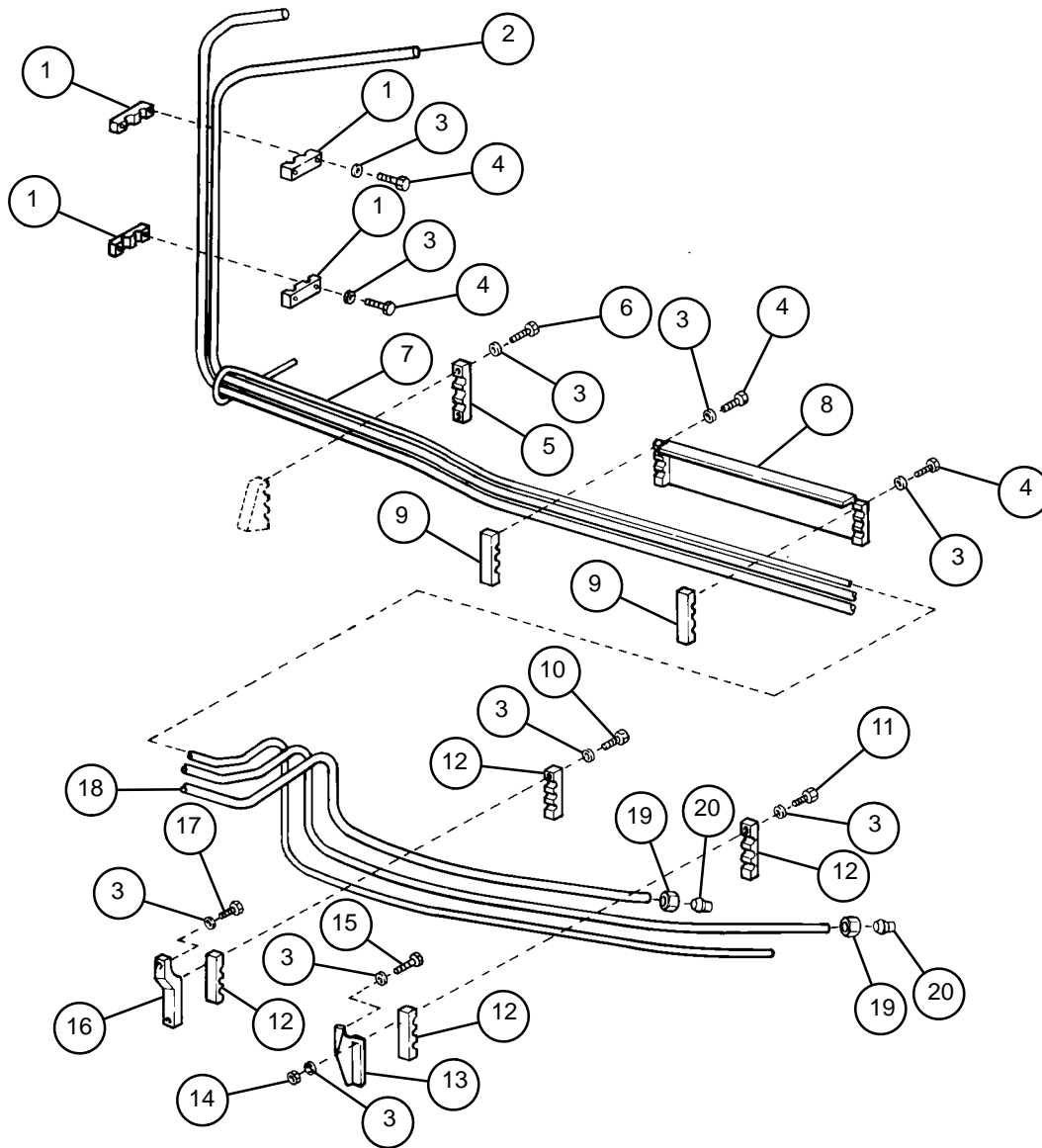


## LEGEND:

1. Bent metallic tube
2. Nut (3)
3. Clinch sleeve (3)
4. Reducer (2)
5. Adapter
6. Preformed packing (3)
7. Bent metallic tube
8. Preformed packing
9. Adapter
10. Bent metallic tube
11. Tee
12. Tube
13. Nonmetallic hose
14. Hose clamp (2)
15. Bent metallic tube
16. Adapter
17. Hygroscopic breather/air line filter
18. Cap
19. Elbow
20. Adapter
21. Clinch sleeve (2)
22. Coupling nut (2)
23. Bent metallic tube
24. Preformed packing (4)
25. Adapter
26. Bent metallic tube
27. Tee
28. Reducer (3)
29. Pressure gage
30. Mounting bracket
31. Screw
32. Clinch sleeve (4)
33. Coupling nut (4)
34. Bent metallic tube
35. Coupling tube
36. Tee
37. Bent metallic tube
38. Machine bolt
39. Loop clamp
40. Loop clamp
41. Hex nut
42. Pressure switch
43. Safety relief valve
44. Hex nut
45. Lockwasher (4)
46. Machine screw (4)



For installation, follow illustration and legend as a guide. After installation, check hydraulic fluid level (para 6-2).



LEGEND:

- |                        |                         |
|------------------------|-------------------------|
| 1. Retaining strap (4) | 11. Cap screw (2)       |
| 2. Bent metallic tube  | 12. Retaining strap (4) |
| 3. Flat washer (18)    | 13. Pipe bracket        |
| 4. Cap screw (8)       | 14. Hex nut (2)         |
| 5. Retaining strap     | 15. Cap screw           |
| 6. Cap screw (2)       | 16. Retaining strap     |
| 7. Bent metallic tube  | 17. Cap screw           |
| 8. Guard               | 18. Bent metallic tube  |
| 9. Retaining strap (2) | 19. Nut (2)             |
| 10. Cap screw (2)      | 20. Sleeve (2)          |



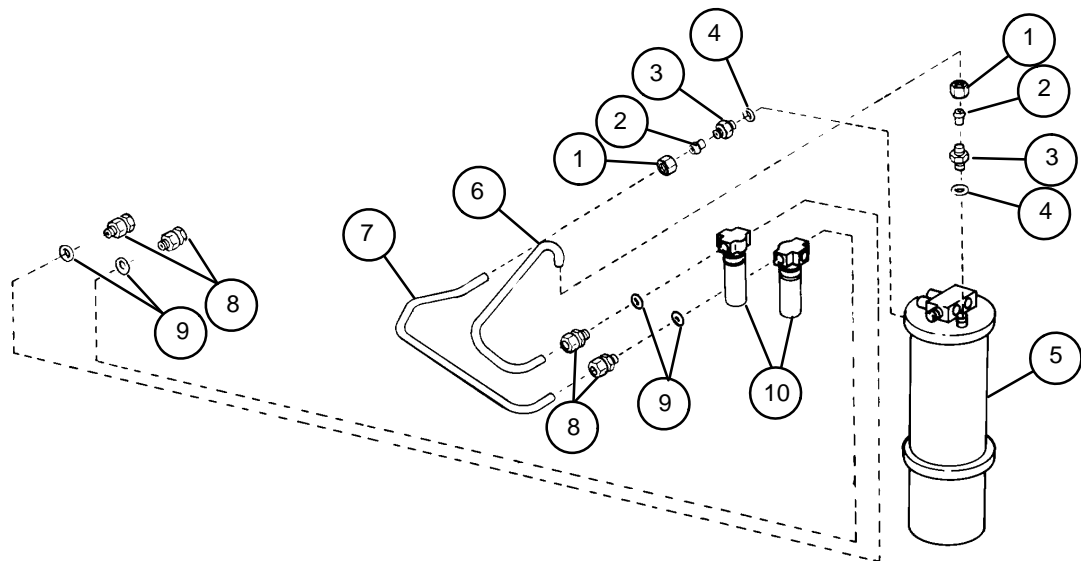


b. Installation

**CAUTION**

When installing any hydraulic fitting, tighten fitting to align with the connecting lines. Repositioning can loosen threads, cause leaks, and damage preformed packings.

For installation, follow illustration and legend as a guide. After installation, check hydraulic fluid level (para 6-2).



LEGEND:

- |                          |                          |
|--------------------------|--------------------------|
| 1. Nut (2)               | 6. Bent metallic tube    |
| 2. Clinch sleeve (2)     | 7. Bent metallic tube    |
| 3. Reducer (2)           | 8. Adapter (2)           |
| 4. Preformed packing (2) | 9. Preformed packing (2) |
| 5. Power pack assembly   | 10. Hydraulic filter (2) |



**NOTE**

- All hydraulic lines and components must be tagged before removal for identification during installation.
- The removal of hydraulic tubes and fittings must be restricted to those items that are to be replaced. Therefore, the legends in this chapter are for identification only.

For removal, follow illustration and legend as a guide. Discard all locknuts, lockwashers, and preformed packings.

**b. Installation****CAUTION**

When installing any hydraulic fitting, tighten fitting to align with the connecting lines. Repositioning can loosen threads, cause leaks, and damage preformed packings.

For installation, follow illustration and legend as a guide. After installation, check hydraulic fluid level (para 6-2).

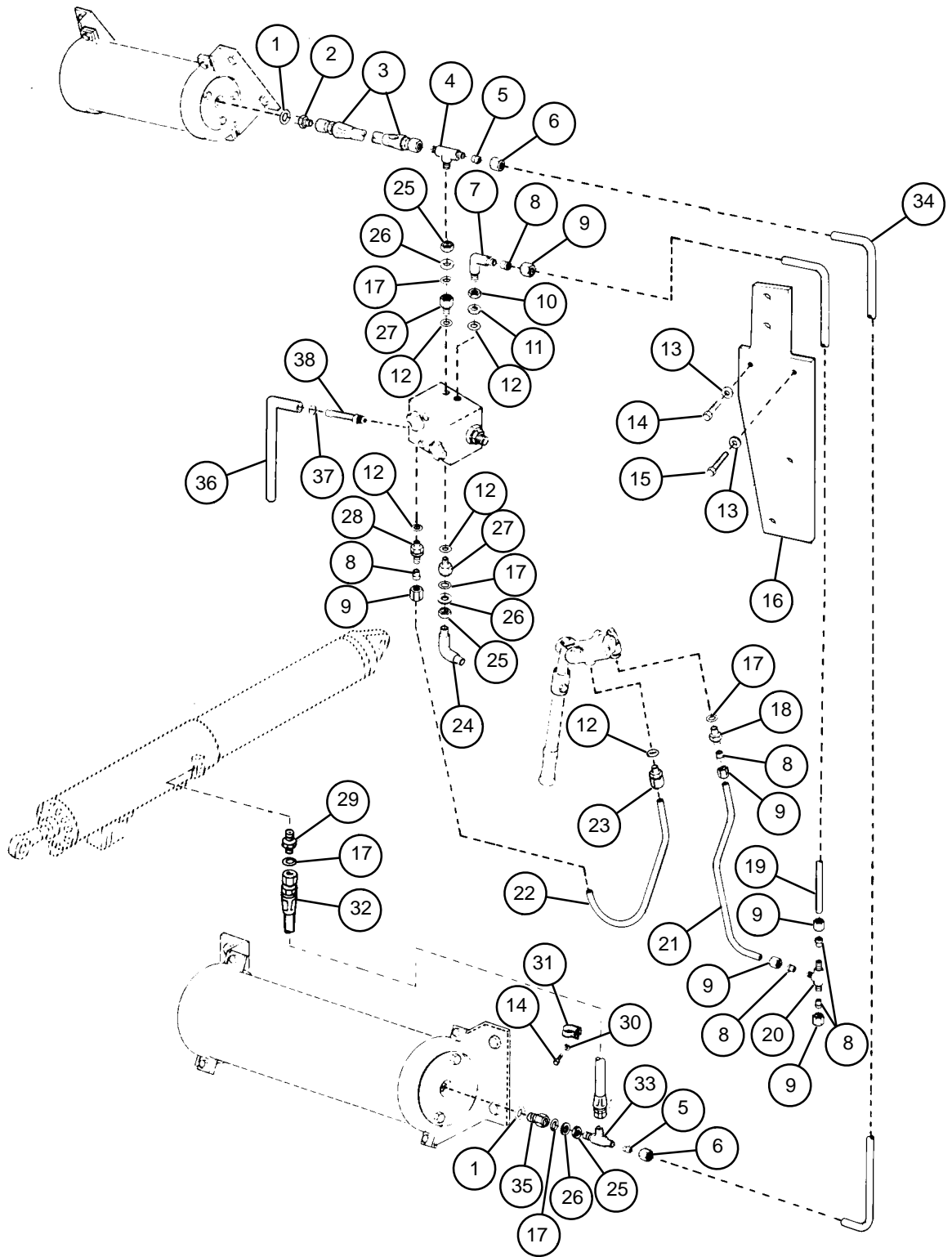
---

**6-25 LINES AND FITTINGS FROM PRIMARY AND SECONDARY ACCUMULATORS TO  
EQUILIBRATED ELEVATING CYLINDER — CONTINUED**

---

LEGEND:

- |                              |                               |
|------------------------------|-------------------------------|
| 1. Preformed packing (2)     | 20. Tee                       |
| 2. Reducer                   | 21. Bent metallic tube        |
| 3. Nonmetallic hose assembly | 22. Bent metallic tube        |
| 4. Tee                       | 23. Adapter                   |
| 5. Clinch sleeve (2)         | 24. Elbow                     |
| 6. Nut (2)                   | 25. Tube fitting locknut (3)  |
| 7. Elbow                     | 26. Flat washer (3)           |
| 8. Clinch sleeve (6)         | 27. Reducer                   |
| 9. Nut (6)                   | 28. Check valve               |
| 10. Tube fitting locknut     | 29. Tube nipple               |
| 11. Packing retainer         | 30. Lockwasher (3)            |
| 12. Preformed packing (5)    | 31. Loop clamp (3)            |
| 13. Flat washer (2)          | 32. Nonmetallic hose assembly |
| 14. Cap screw (4)            | 33. Tee                       |
| 15. Cap screw                | 34. Bent metallic tube        |
| 16. Manifold plate assembly  | 35. Bushing                   |
| 17. Preformed packing (5)    | 36. Nonmetallic hose          |
| 18. Reducer                  | 37. Hose clamp                |
| 19. Bent metallic tube       | 38. Adapter                   |





**NOTE**

- All hydraulic lines and components must be tagged before removal for identification during installation.
- The removal of hydraulic tubes and fittings must be restricted to those items that are to be replaced. Therefore, the legends in this chapter are for identification only.

For removal, follow illustration and legend as a guide. Discard all preformed packings.

**b. Installation****CAUTION**

When installing any hydraulic fitting, tighten fitting to align with the connecting lines. Repositioning can loosen threads, cause leaks, and damage preformed packings.

For installation, follow illustration and legend as a guide. After installation, check hydraulic fluid level (para 6-2).

---

**6-26 LINES AND FITTINGS FROM TRAVERSING MECHANISM — CONTINUED**

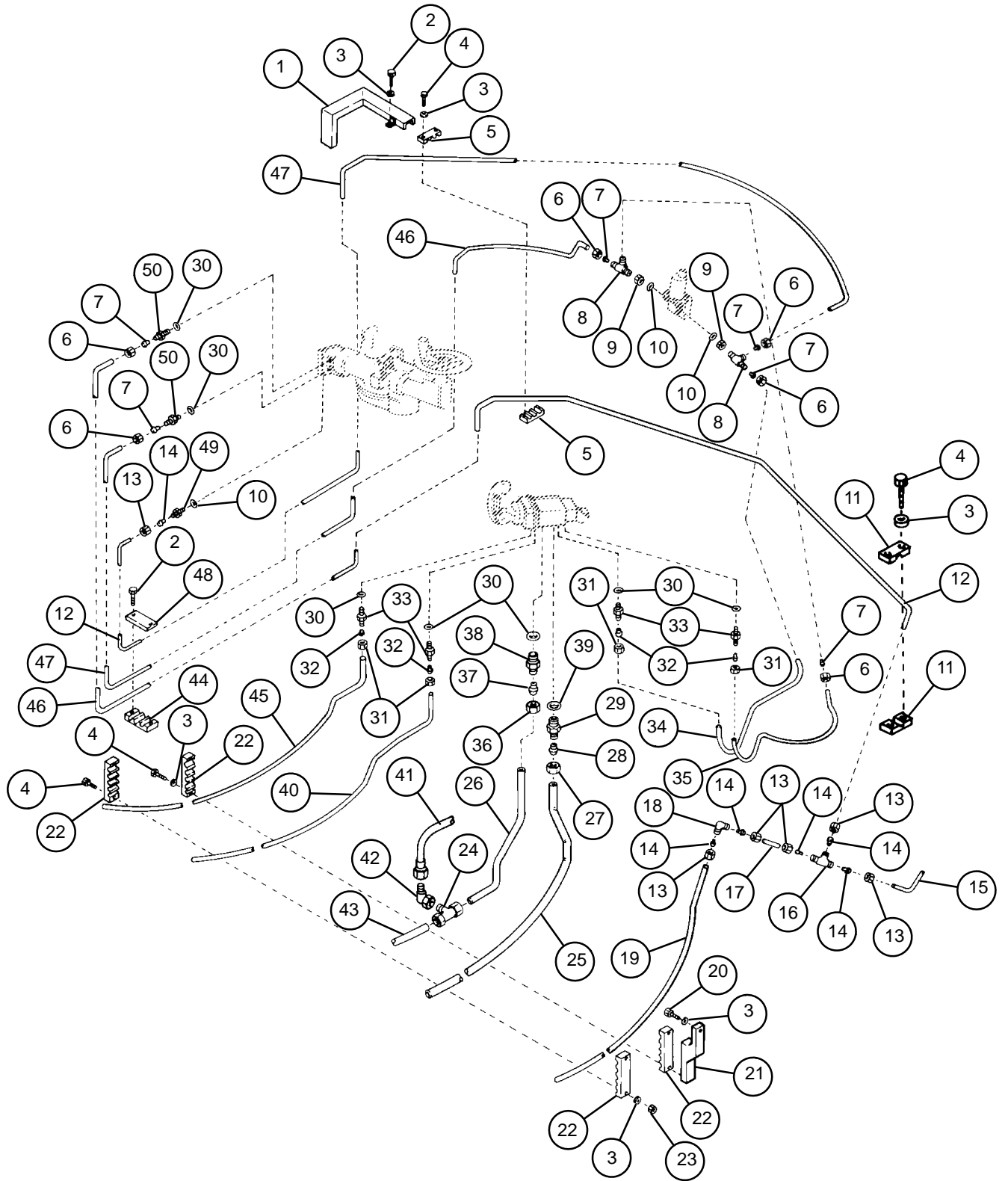
---

LEGEND:

- |  |  |
|--|--|
| 1. Guard   | 26. Bent metallic tube (M109A2/M109A3)   |
| 2. Cap screw (5)   | 27. Nut (M109A2/M109A3)  |
| 3. Flat washer (12)  | 28. Clinch sleeve (M109A2/M109A3)  |
| 4. Cap screw (8)   | 29. Reducer (M109A2/M109A3)  |
| 5. Retaining strap (2)   | 30. Preformed packing (7) (Preformed packing leading from bent metallic tube (26) is M109A2/M109A3 only) |
| 6. Coupling nut (6)  | 31. Coupling nut (4)   |
| 7. Clinch sleeve (6)   | 32. Clinch sleeve (4)  |
| 8. Tee (2)   | 33. Adapter (4)  |
| 9. Hex nut (2)   | 34. Bent metallic tube   |
| 10. Preformed packing (3)  | 35. Bent metallic tube   |
| 11. Bracket (2)  | 36. Hex nut (M109A2/M109A3)  |
| 12. Bent metallic tube (traverse mechanism to right elevation control) | 37. Clinch sleeve (M109A2/M109A3)  |
| 13. Hex nut (6)  | 38. Tube nipple (M109A2/M109A3)  |
| 14. Clinch sleeve (6)  | 39. Preformed packing (M109A2/M109A3)  |
| 15. Bent metallic tube (to tee on equilibrator)                        | 40. Bent metallic tube   |
| 16. Tee  | 41. Nonmetallic hose assembly  |
| 17. Tube Coupling  | 42. Elbow  |
| 18. Elbow  | 43. Bent metallic tube   |
| 19. Bent metallic tube (traverse mechanism to power pack)              | 44. Bracket  |
| 20. Cap screw  | 45. Bent metallic tube   |
| 21. Mounting clamp   | 46. Bent metallic tube   |
| 22. Retaining strap (4)  | 47. Bent metallic tube   |
| 23. Hex nut (2)  | 48. Retaining strap  |
| 24. Tee (2)  | 49. Reducer  |
| 25. Bent metallic tube (M109A2/M109A3)                                 | 50. Reducer (2)  |

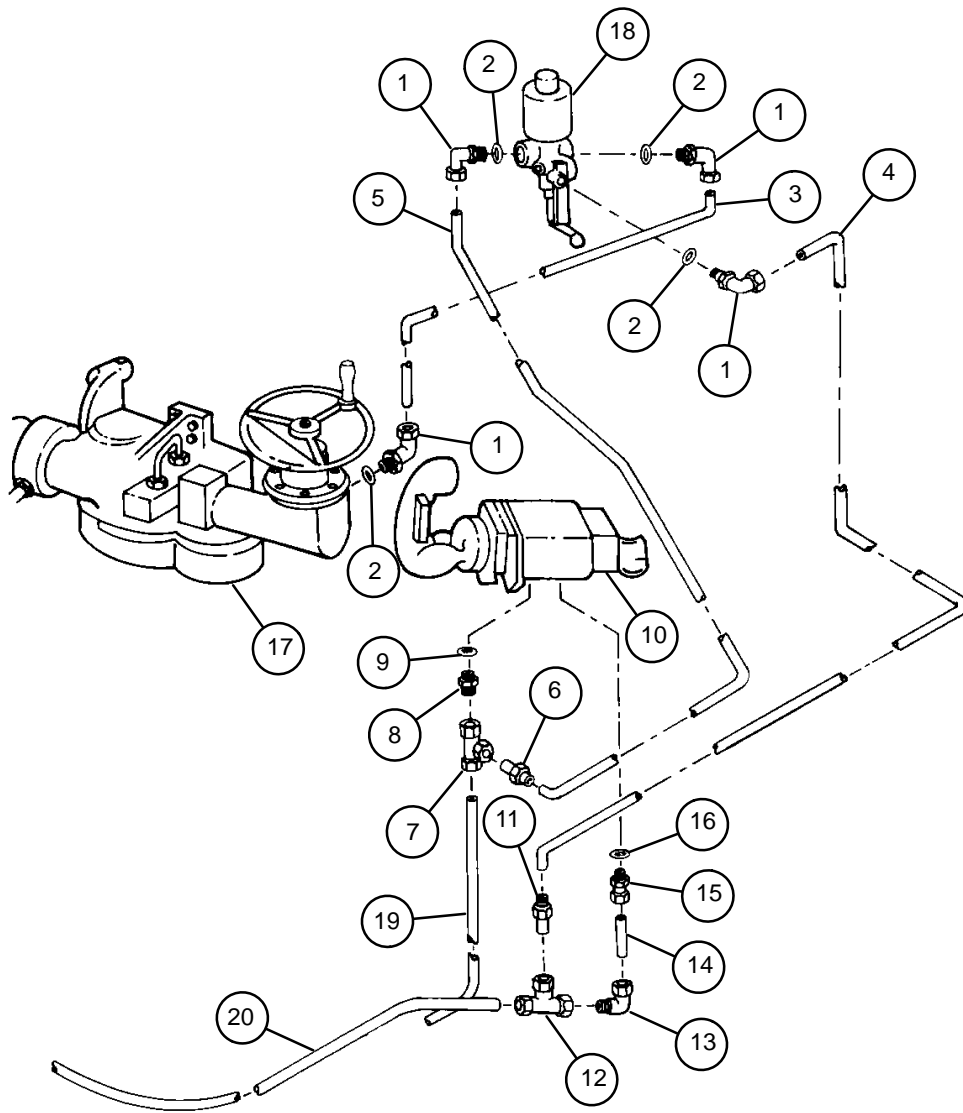
See also lines and fittings from clutch valve (para 6-27).







For installation, follow illustration and legend as a guide. After installation, check hydraulic fluid level (para 6-2).

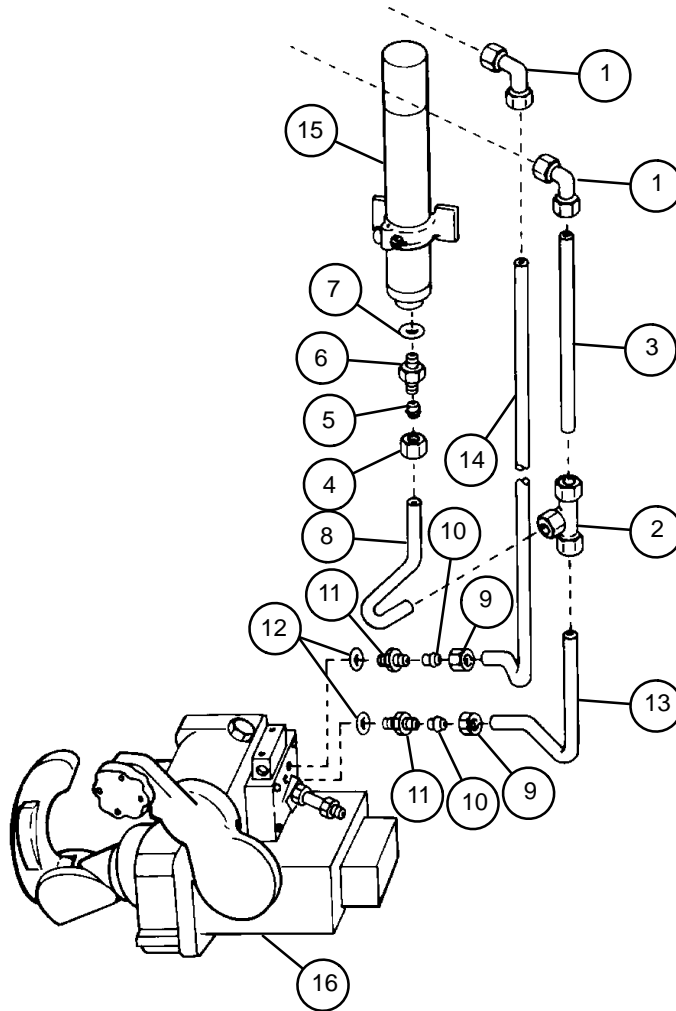


LEGEND:

- |                               |                          |
|-------------------------------|--------------------------|
| 1. Elbow (4)                  | 11. Reducer              |
| 2. Preformed packing (4)      | 12. Tee                  |
| 3. Bent metallic tube         | 13. Elbow                |
| 4. Bent metallic tube         | 14. Metallic tube        |
| 5. Bent metallic tube         | 15. Adapter              |
| 6. Reducer                    | 16. Preformed packing    |
| 7. Tee                        | 17. Traversing mechanism |
| 8. Adapter                    | 18. Clutch valve         |
| 9. Preformed packing          | 19. Bent metallic tube   |
| 10. Gunner's control assembly | 20. Bent metallic tube   |



For installation, follow illustration and legend as a guide. After installation, check hydraulic fluid level (para 6-2).



LEGEND:

- |                       |  |
|-----------------------|--|
| 1. Elbow (2)          | 10. Clinch sleeve (2)  |
| 2. Tee                | 11. Adapter (2)  |
| 3. Metallic tube      | 12. Preformed packing (2)  |
| 4. Nut                | 13. Bent metallic tube (control assembly to accumulator assembly (manual)) |
| 5. Clinch sleeve      | 14. Bent metallic tube (control assembly to elevation cylinder)            |
| 6. Adapter            | 15. Manual elevation accumulator   |
| 7. Preformed packing  | 16. Assistant gunner's control assembly                                    |
| 8. Bent metallic tube |  |
| 9. Nut (2)            |  |

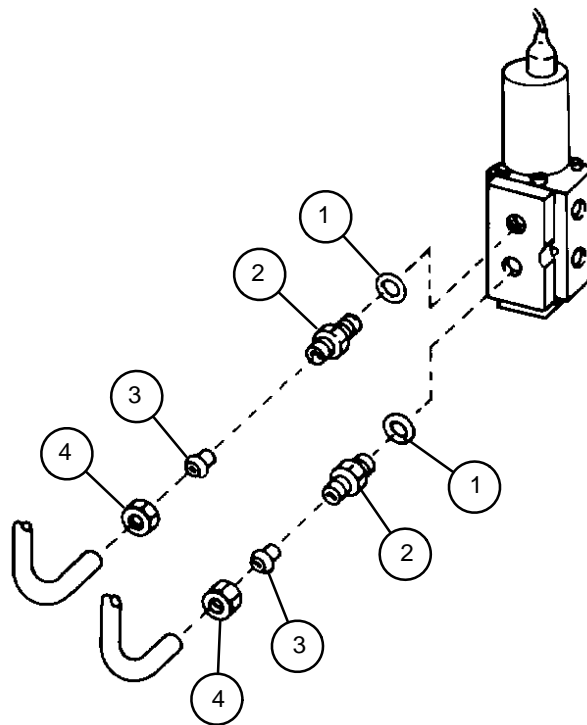


**b. Installation**

**CAUTION**

When installing any hydraulic fitting, tighten fitting to align with the connecting lines. Repositioning can loosen threads, cause leaks, and damage preformed packings.

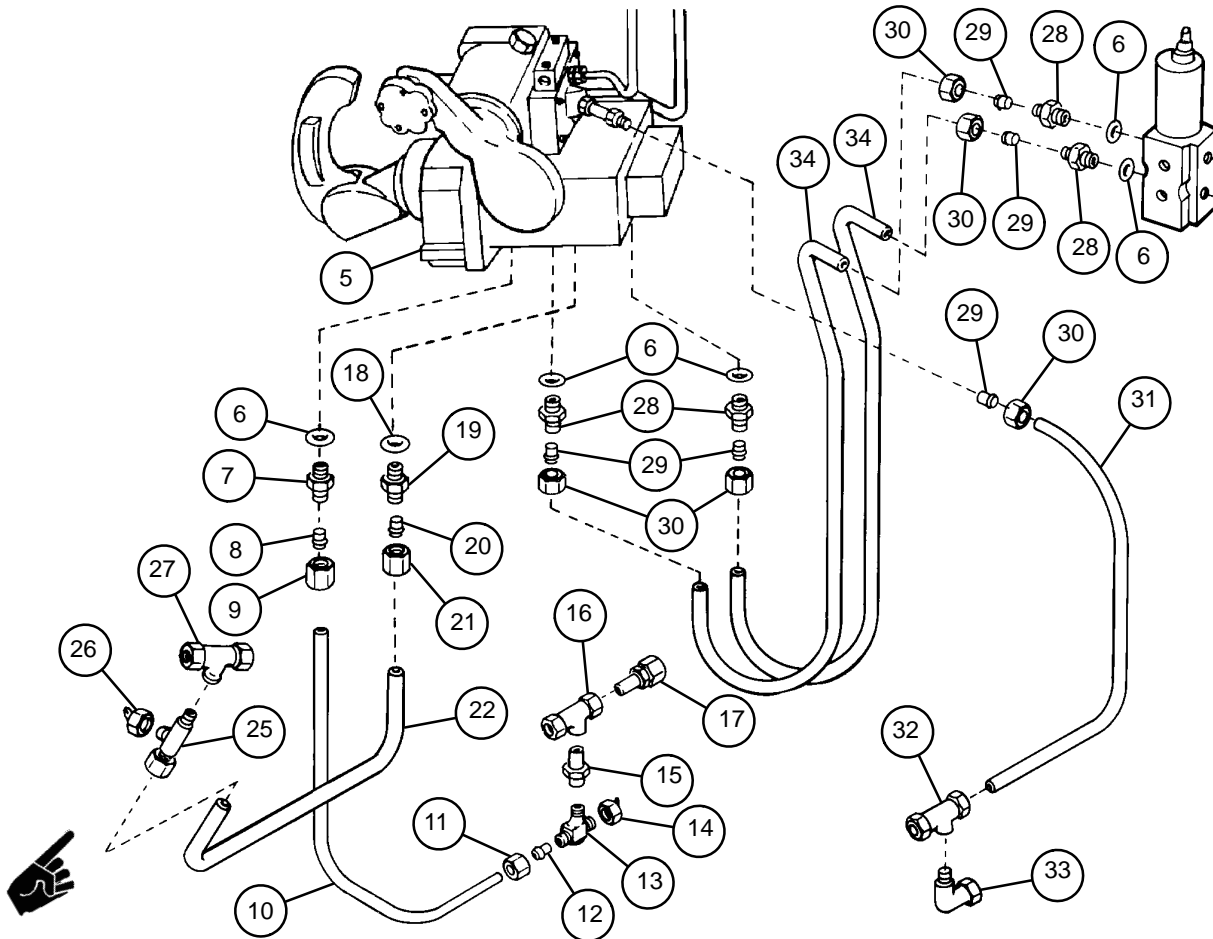
For installation, follow illustration and legend as a guide. After installation, check hydraulic fluid level (para 6-2).



**LEGEND:**

- 1. Preformed packing (2)
- 2. Adapter (2)
- 3. Clinch sleeve (2)
- 4. Coupling nut (2)

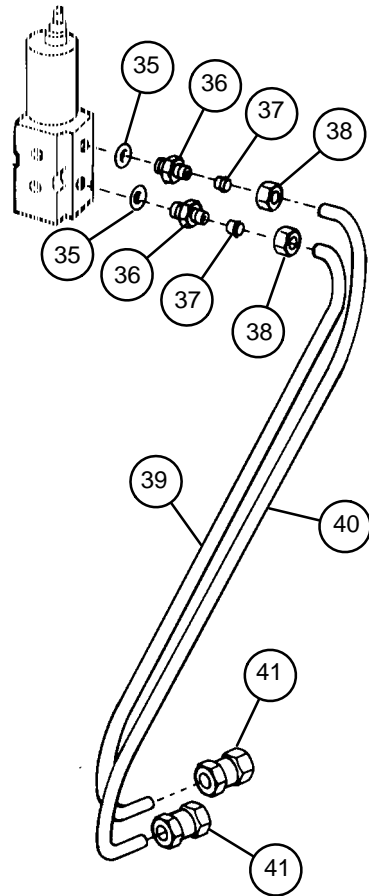
**6-29 LINES AND FITTINGS FROM ELEVATION SELECTOR VALVE ASSEMBLY  
— CONTINUED**



**LEGEND:**

- |   |  |
|---|--|
| 5. Assistant gunner's control assembly                            | 21. Nut  |
| 6. Preformed packing (5)  | 22. Bent metallic tube (assistant gunner's control to power pack)                                      |
| 7. Nipple   | 23. (Deleted)  |
| 8. Clinch sleeve  | 24. (Deleted)  |
| 9. Nut  | 25. Tee  |
| 10. Bent metallic tube (power pack to assistant gunner's control) | 26. Cap  |
| 11. Nut   | 27. Tee  |
| 12. Clinch sleeve   | 28. Adapter (4)  |
| 13. Tee   | 29. Clinch sleeve (5)  |
| 14. Cap   | 30. Nut (5)  |
| 15. Reducer   | 31. Bent metallic tube (assistant gunner's control to power pack)                                      |
| 16. Tee   | 32. Tee  |
| 17. Reducer assembly  | 33. Elbow  |
| 18. Preformed packing   | 34. Bent metallic preformed tube (elevation selector valve assembly to assistant gunner's control) (2) |
| 19. Reducer   |  |
| 20. Clinch sleeve   |  |





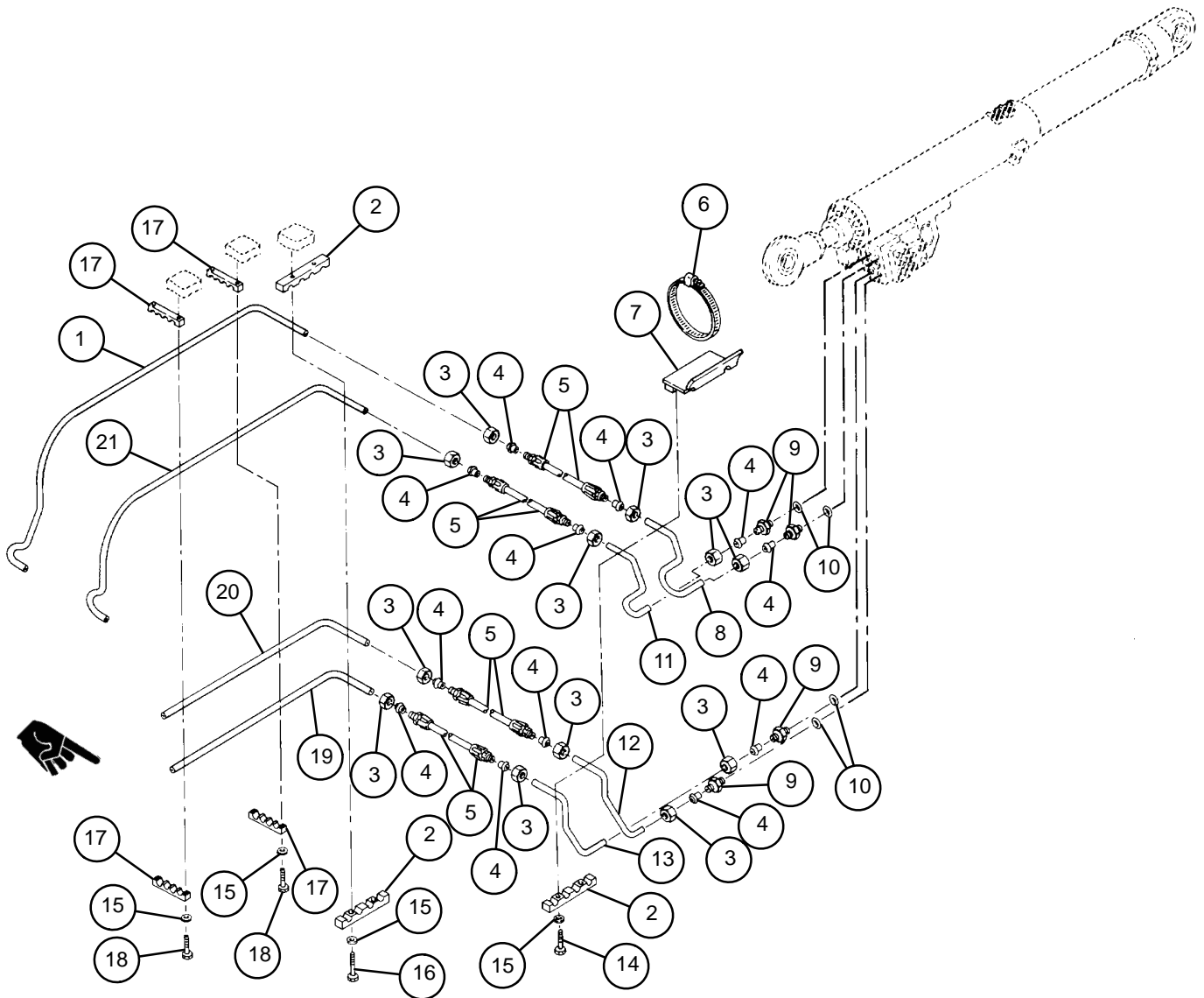
LEGEND:

- 35. Preformed packing (2)
- 36. Adapter (2)
- 37. Clinch sleeve (2)
- 38. Nut (2)

- 39. Bent metallic tube (selector valve to gunner's control) (2)
- 40. Bent metallic tube
- 41. Nipple (2)



For installation, follow illustration and legend as a guide. After installation, check hydraulic fluid level (para 6-2).



LEGEND:

- |  |   |
|--|---|
| <ul style="list-style-type: none"> <li>1. Bent metallic tube (elevating cylinder to elevation selector valve assembly)</li> <li>2. Bracket (3)</li> <li>3. Nut (12)</li> <li>4. Clinch sleeve (12)</li> <li>5. Nonmetallic hose assembly (4)</li> <li>6. Hose clamp (2)</li> <li>7. Bracket</li> <li>8. Bent metallic tube</li> <li>9. Adapter (4)</li> <li>10. Preformed packing (4)</li> <li>11. Bent metallic tube</li> </ul> | <ul style="list-style-type: none"> <li>12. Bent metallic tube</li> <li>13. Bent metallic tube</li> <li>14. Cap screw (2)</li> <li>15. Flat washer (8)</li> <li>16. Cap screw (2)</li> <li>17. Bracket (4)</li> <li>18. Cap screw (4)</li> <li>19. Bent metallic tube (elevating cylinder to assistant gunner's control)</li> <li>20. Bent metallic tube (elevating cylinder to accumulator (manual))</li> <li>21. Bent metallic tube (elevating cylinder to elevation selector valve assembly)</li> </ul> |
|--|---|

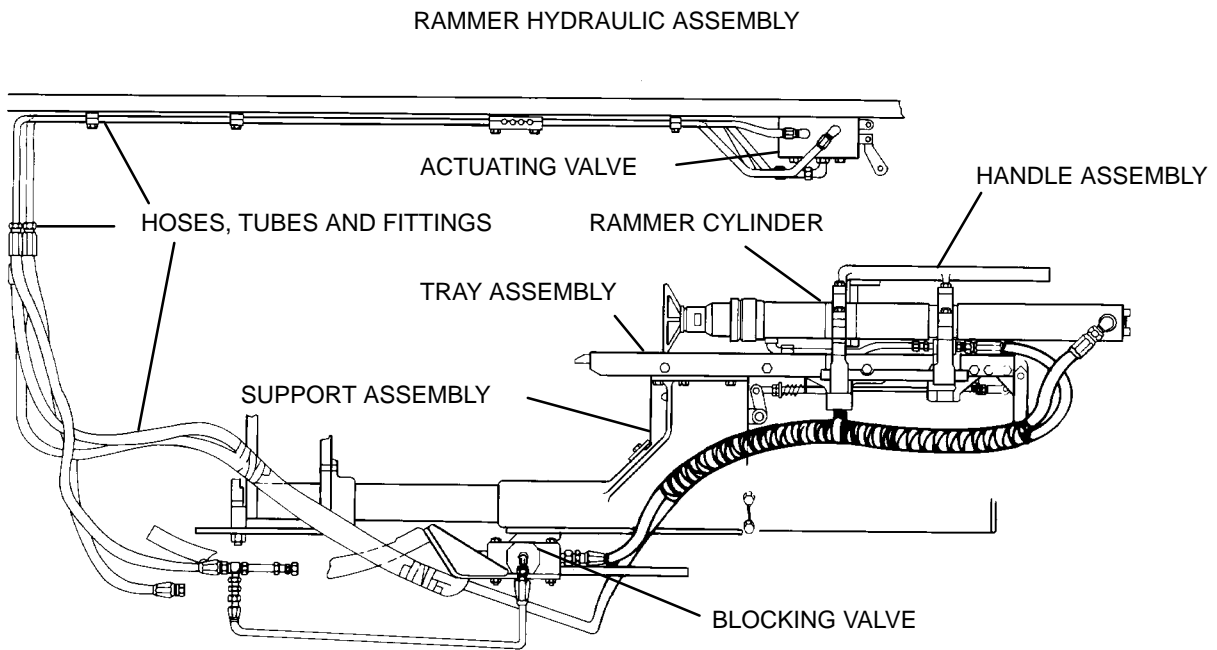


## CHAPTER 7 RAMMER SYSTEM

### GENERAL

This chapter illustrates and describes maintenance procedures for the projectile rammer system. Step-by-step procedures are provided for reliability checks, adjustment, removal and installation, as required for the performance of unit level maintenance.

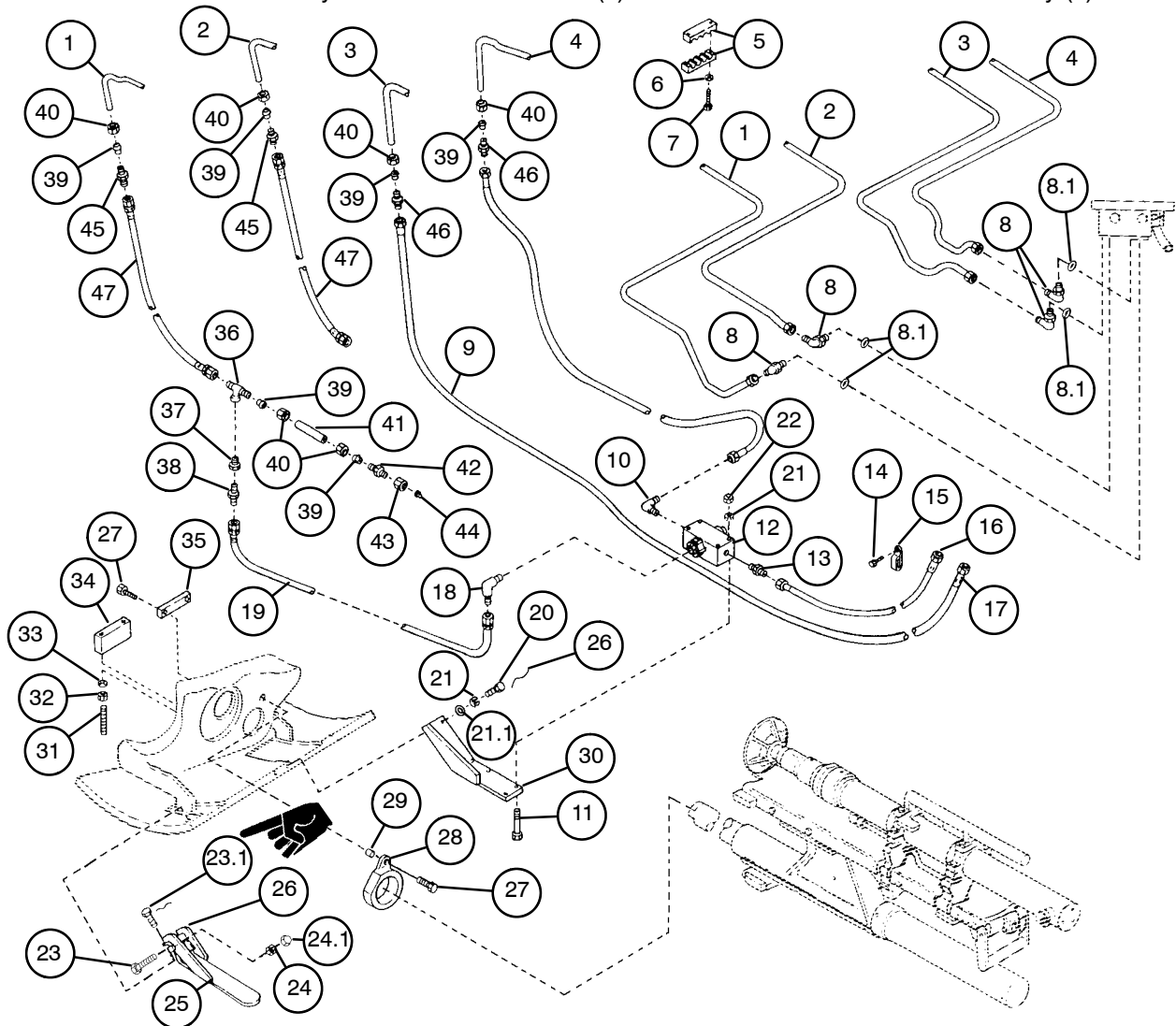
<u>CONTENTS</u>		<u>Page</u>
7-1	RAMMER LINES AND FITTINGS .....	7-2
7-2	RAMMER ASSEMBLY .....	7-4
7-3	RAMMER RELIABILITY CHECKS .....	7-14
7-4	ACTUATING VALVE .....	7-17





LEGEND:

- |                                |                                |                                    |
|--------------------------------|--------------------------------|------------------------------------|
| 1. Bent metallic tube          | 18. Elbow                      | 32. Hex nut (2)                    |
| 2. Bent metallic tube          | 19. Non-metallic hose assembly | 33. Flat washer (2)                |
| 3. Bent metallic tube          | 20. Cap screw (2)              | 34. Positioning block              |
| 4. Bent metallic tube          | 21. Lockwasher (6)             | 35. Retaining plate                |
| 5. Bracket (10)                | 21.1. Washer (2)               | 36. Tee                            |
| 6. Flat washer (10)            | 22. Hex nut (4)                | 37. Bushing                        |
| 7. Cap screw (10)              | 23. Cap screw (2)              | 38. Adapter                        |
| 8. Elbow ( 4)                  | 23.1. Cap screw (2)            | 39. Clinch sleeve (6)              |
| 8.1. Preformed packing (4)     | 24. Hex nut (2)                | 40. Nut (6)                        |
| 9. Non-metallic hose assembly  | 24.1. Cap nut (2)              | 41. Hollow pin                     |
| 10. Elbow                      | 25. Mounting bracket           | 42. Adapter                        |
| 11. Cap screw (4)              | 26. Lockwire                   | 43. Nut                            |
| 12. Blocking check valve       | 27. Cap screw (3)              | 44. Clinch sleeve                  |
| 13. Adapter                    | 28. Rammer bumper              | 45. Nipple (2)                     |
| 14. Machine screw              | 29. Sleeve spacer              | 46. Nipple (2)                     |
| 15. Loop clamp                 | 30. Angle bracket              | 47. Non-metallic hose assembly (2) |
| 16. Non-metallic hose assembly | 31. Setscrew (2)               |                                    |
| 17. Non-metallic hose assembly |                                |                                    |



---

## 7-2 RAMMER ASSEMBLY

---

- This task covers:
- |                          |                |
|--------------------------|----------------|
| a. Removal               | b. Disassembly |
| c. Inspection and Repair | d. Assembly    |
| e. Installation          | f. Adjustment  |
- 

### **INITIAL SETUP**

#### Tools

Artillery and turret mechanic's tool kit  
(CL 5180-95-A12, see SC 9999-01-SKO)  
Torque wrench (item 18, Appx H)

#### Materials/Parts

Cloth, crocus (item 10, Appx D)  
CLP (item 8, Appx D)  
Cotter pins (3) (item 37, Appx G)  
Cover gasket (item 140, Appx G)  
Hydraulic fluid, OHT (item 21, Appx D)  
Lockwashers (2) (item 79, Appx G)  
Lockwashers (6) (item 81, Appx G)  
Lockwashers (7) (item 66, Appx G)  
Lockwire (V) (item 106, Appx G)

Lockwire (V) (item 33, Appx G)  
Sealing compound (item 29, Appx D)  
Spring pin (item 7, Appx G)  
Spring pin (item 16, Appx G)  
Spring pins (2) (item 13, Appx G)

#### Personnel Required

2

#### Equipment Condition

Set cannon at 0° elevation  
Discharge hydraulic pressure (para 6-3)  
Remove rammer lines and fittings (para 7-1)

#### References

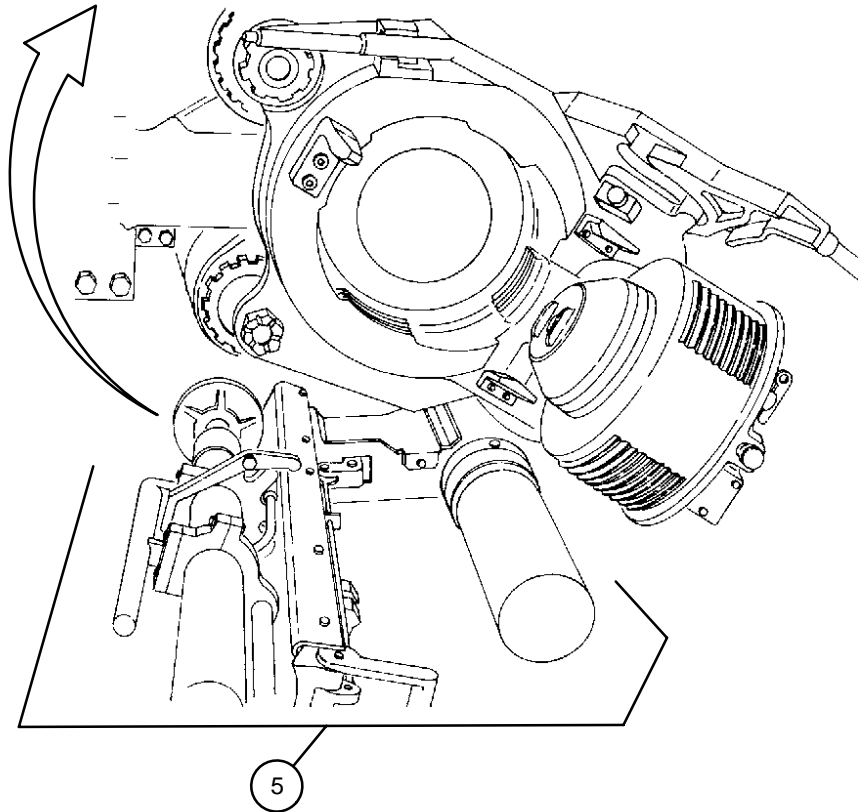
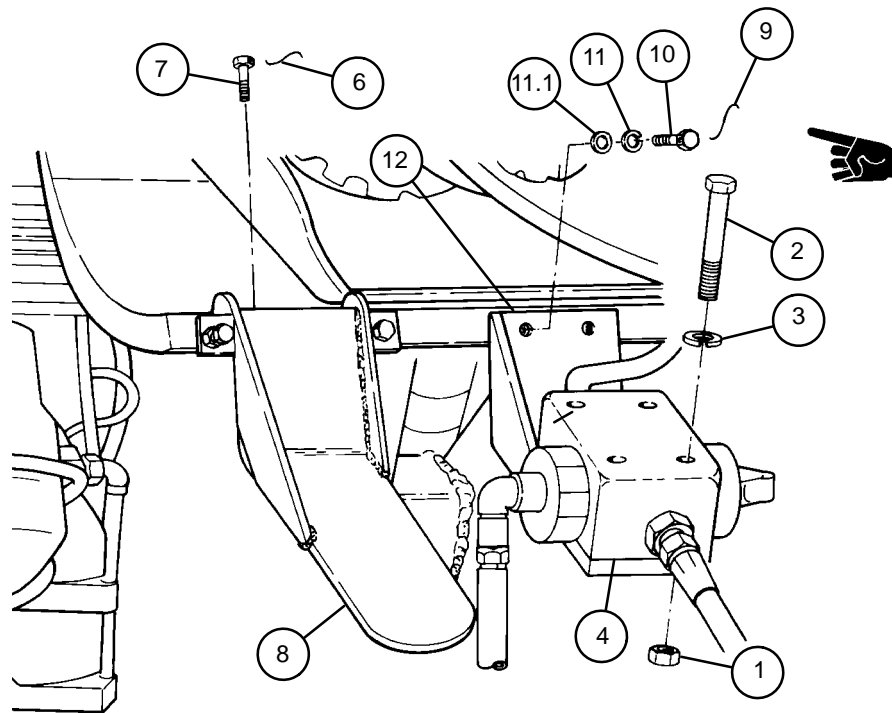
TM 9-2350-311-10

---

### **a. Removal**

- 1 Remove four hex nuts (1), four cap screws (2), four lockwashers (3), and blocking check valve (4). Discard lockwashers.
- 2 Move rammer assembly (5) to ram position.
- 3 Remove lockwire (6), two cap screws (7), and rammer mounting bracket (8). Discard lockwire.
- 4 Remove lockwire (9), two cap screws (10), two lockwashers (11), two flat washers (11.1), and angle bracket (12). Discard lockwashers and lockwire.





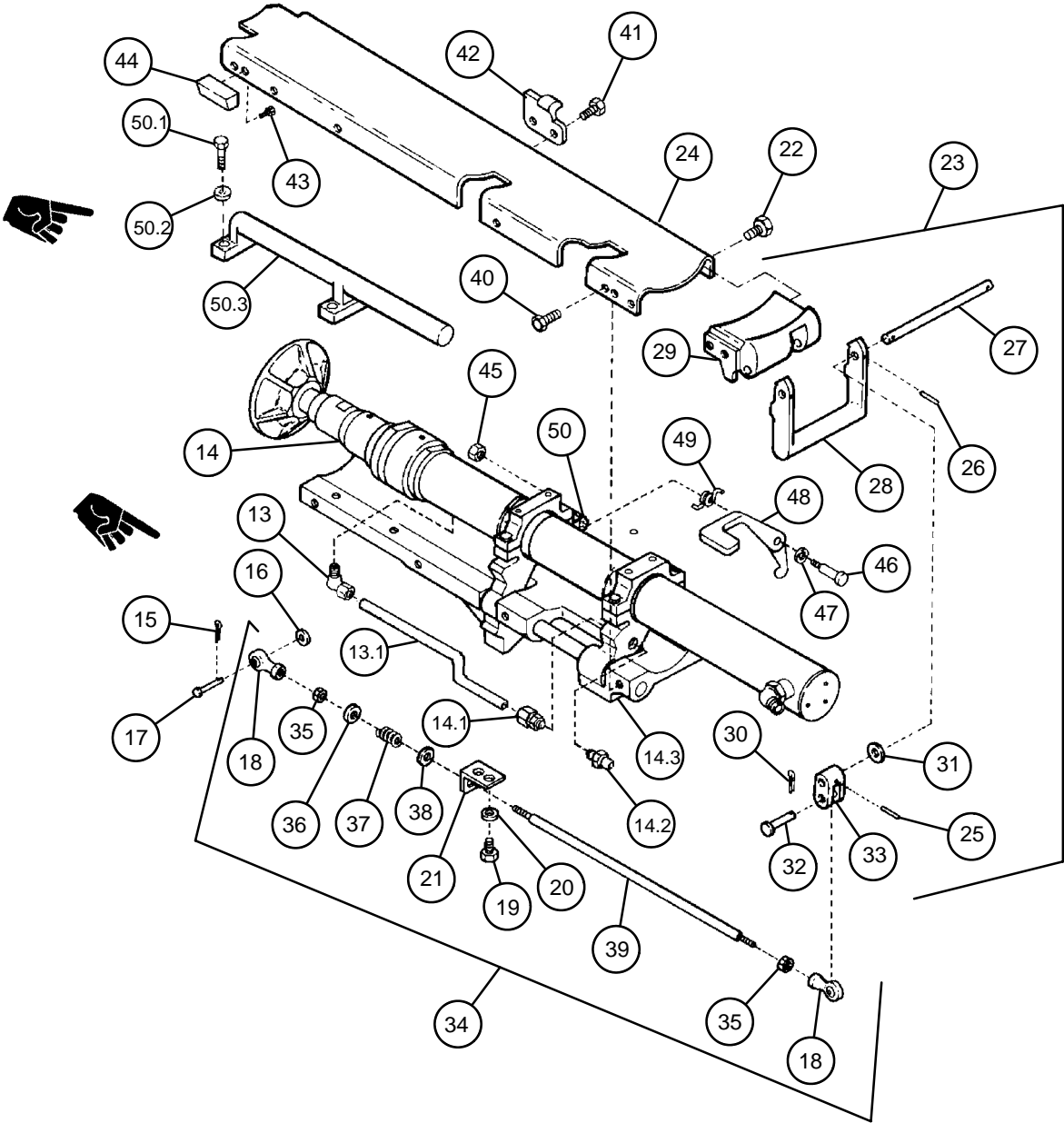
---

## 7-2 RAMMER ASSEMBLY — CONTINUED

---

### b. Disassembly

- 1 Remove elbow (13) and metallic tube (13.1) from cylinder assembly (14).
- 2 Remove adapter (14.1) and adapter (14.2) from rear cylinder support (14.3).
- 3 Remove cotter pin (15) and flat washer (16) from straight headed pin (17). Discard cotter pin.
- 4 Withdraw straight headed pin (17) from one rod end bearing (18).
- 5 Remove two cap screws (19) and two flat washers (20) from angle bracket (21).
- 6 Remove four cap screws (22) and handle group (23) from tray (24).
- 7 Remove spring pin (25), two spring pins (26), straight headless pin (27), and handle (28) from mounting bracket (29). Discard spring pins.
- 8 Remove cotter pin (30), flat washer (31), straight headed pin (32), and lever (33) from mounting bracket (29). Discard cotter pin.
- 9 Remove rod group (34).
- 10 Remove two rod end bearings (18), two hex nuts (35), flat washer (36), helical compression spring (37), flat washer (38), and angle bracket (21) from rod (39).
- 11 Remove seven cap screws (40), two cap screws (41), rammer latch (42), and tray (24).
- 12 Remove two cap screws (43) and mounting bracket (44) from tray (24).
- 13 Remove hex nut (45), shoulder bolt (46), flat washer (47), lock-release lever (48), and helical torsion spring (49) from front cylinder support (50).
- 14 Remove four cap screws (50.1), four flat washers (50.2), and rammer handle (50.3).

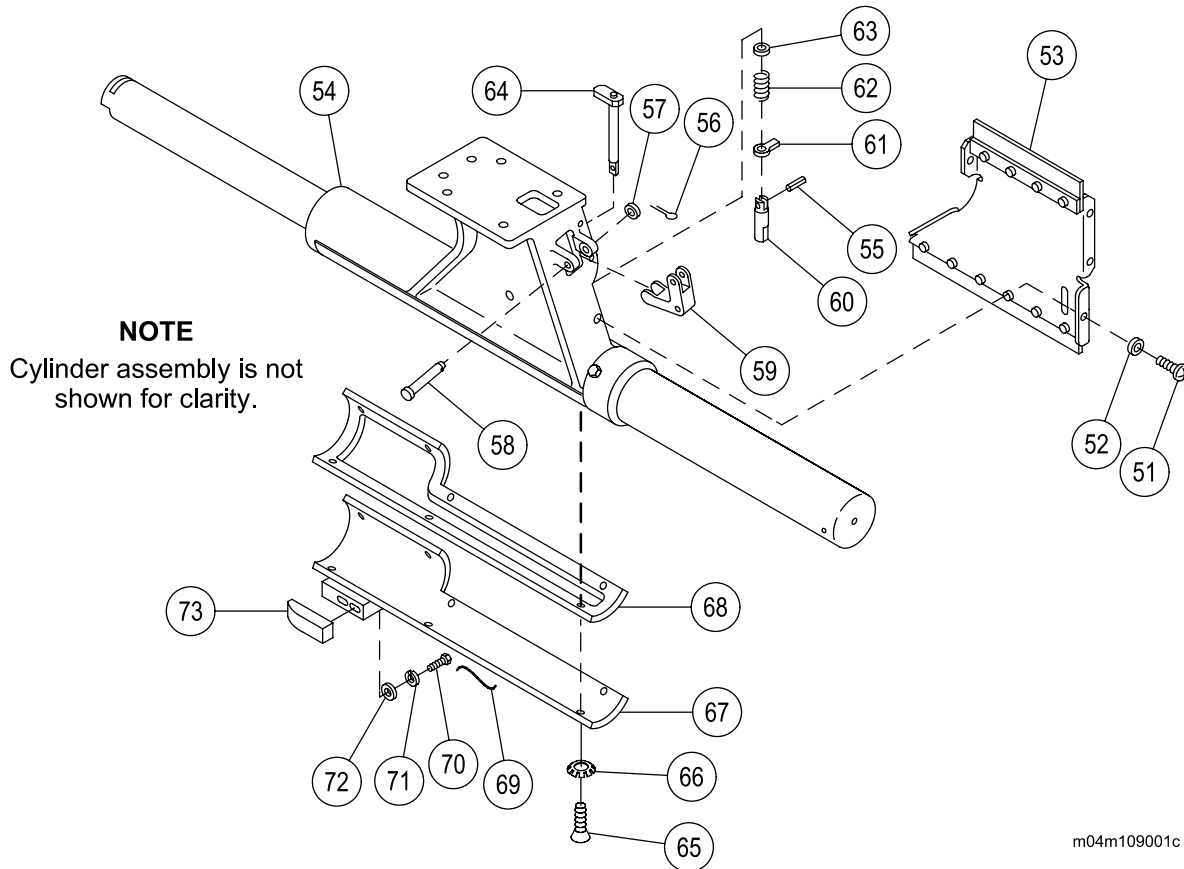


**NOTE**  
Rammer support group is not shown for clarity.

## 7-2 RAMMER ASSEMBLY — CONTINUED

### b. Disassembly — Continued

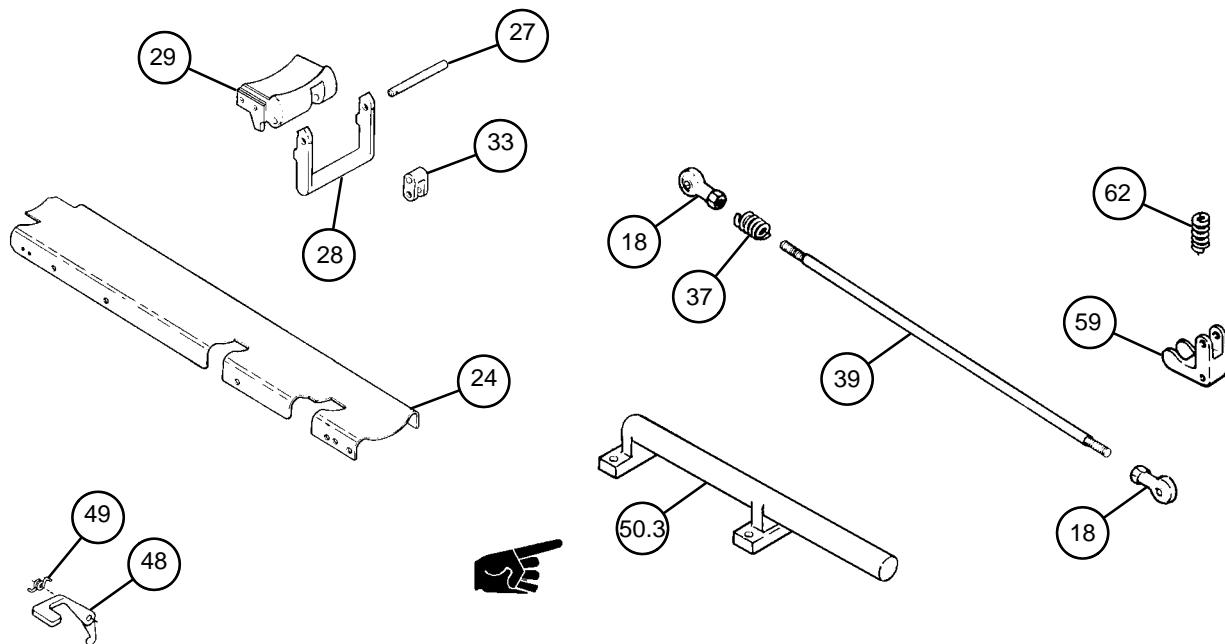
- 15 Remove five machine screws (51), five flat washers (52), and cover (53) from rammer support group (54).
- 16 Remove spring pin (55) and discard.
- 17 Remove cotter pin (56), flat washer (57), straight headed pin (58), and actuating lever (59). Discard cotter pin.
- 18 Remove shoulder pin (60), dial pointer (61), helical compression spring (62), flat washer (63), and actuator (64).
- 19 Remove seven machine screws (65), seven lockwashers (66), cover (67), and cover gasket (68) from rammer support group (54). Discard cover gasket, and lockwashers.
- 20 Remove lockwire (69), two cap screws (70), two lockwashers (71), two flat washers (72), and bridge clamp (73) from cover (67). Discard lockwire and lockwashers.



m04m109001c

**c. Inspection and Repair**

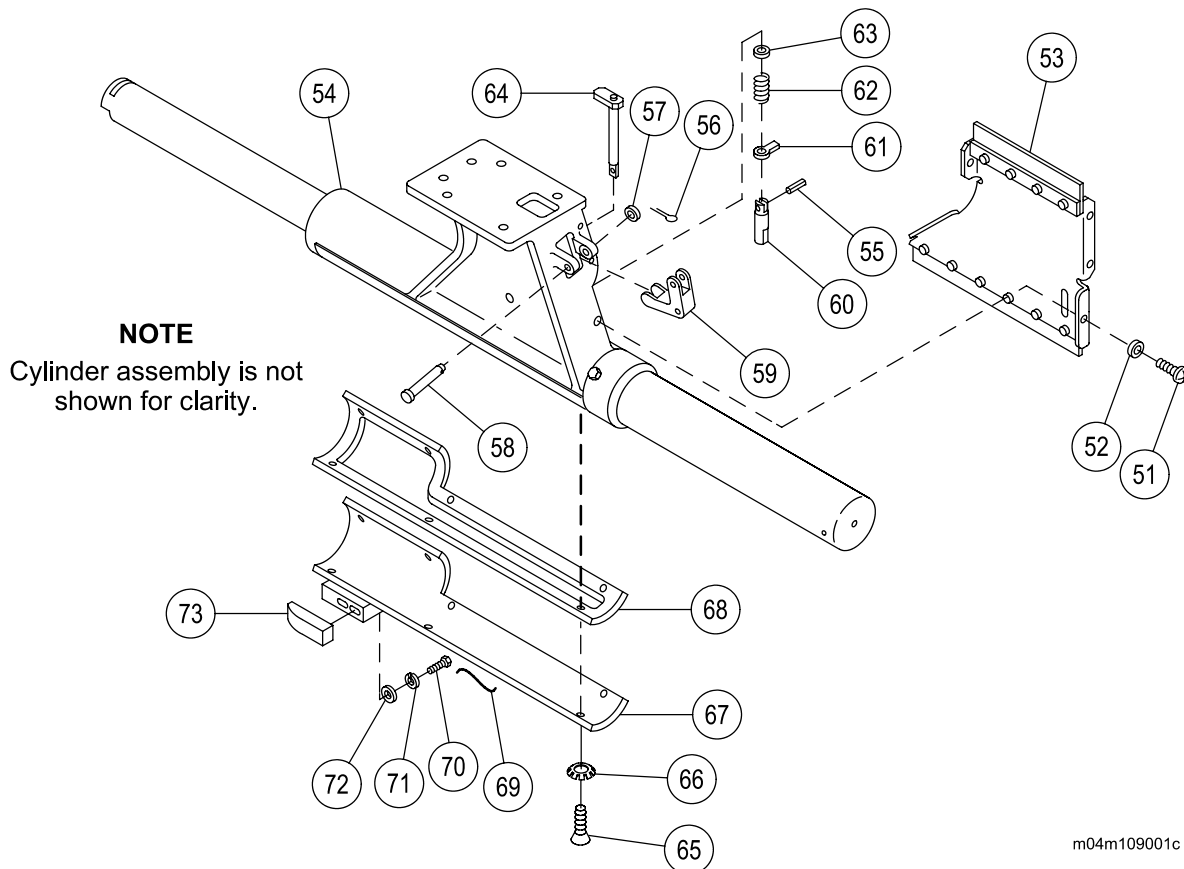
- 1 Inspect lock-release lever (48). Replace if cracked or severely worn.
- 2 Inspect helical torsion spring (49). Replace if distorted or cracked.
- 3 Inspect tray (24). Replace if cracked, broken, or distorted.
- 4 Inspect mounting bracket (29). Replace if cracked, broken, or distorted. Remove burrs with crocus cloth. Chase damaged threads.
- 5 Inspect straight headless pin (27). Replace if bent, cracked, or distorted.
- 6 Inspect lever (33) for cracks, burrs, or visible distortion. Replace if cracked, burred or distorted.
- 7 Inspect handle (28). Replace if cracked, broken, or distorted.
- 8 Inspect two rod end bearings (18) and ensure free rotation. Replace if cracked or corroded.
- 9 Inspect rod (39). Replace if bent or distorted.
- 10 Inspect helical compression spring (37). Replace if distorted, cracked, or nicked.
- 11 Inspect helical compression spring (62). Replace if cracked or distorted.
- 12 Inspect actuating lever (59). Replace if cracked or severely worn.
- 13 Inspect rammer handle (50.3). Replace if cracked, broken, or distorted.



## 7-2 RAMMER ASSEMBLY — CONTINUED

### d. Assembly

- 1 Install bridge clamp (73), two flat washers (72), two new lockwashers (71), and two cap screws (70) on cover (67). Secure cap screws with new lockwire (69).
- 2 Install new cover gasket (68) and cover (67) on rammer support group (54) with seven new lockwashers (66), and seven machine screws (65).
- 3 Install actuator (64), flat washer (63), helical compression spring (62), dial pointer (61), and shoulder pin (60).
- 4 Install actuating lever (59), straight headed pin (58), flat washer (57), and new cotter pin (56).
- 5 Install new spring pin (55).
- 6 Install cover (53), five flat washers (52), and five machine screws (51) to rammer support group (54).



m04m109001c

This page left intentionally blank.

---

## 7-2 RAMMER ASSEMBLY — CONTINUED

---

### d. Assembly — Continued

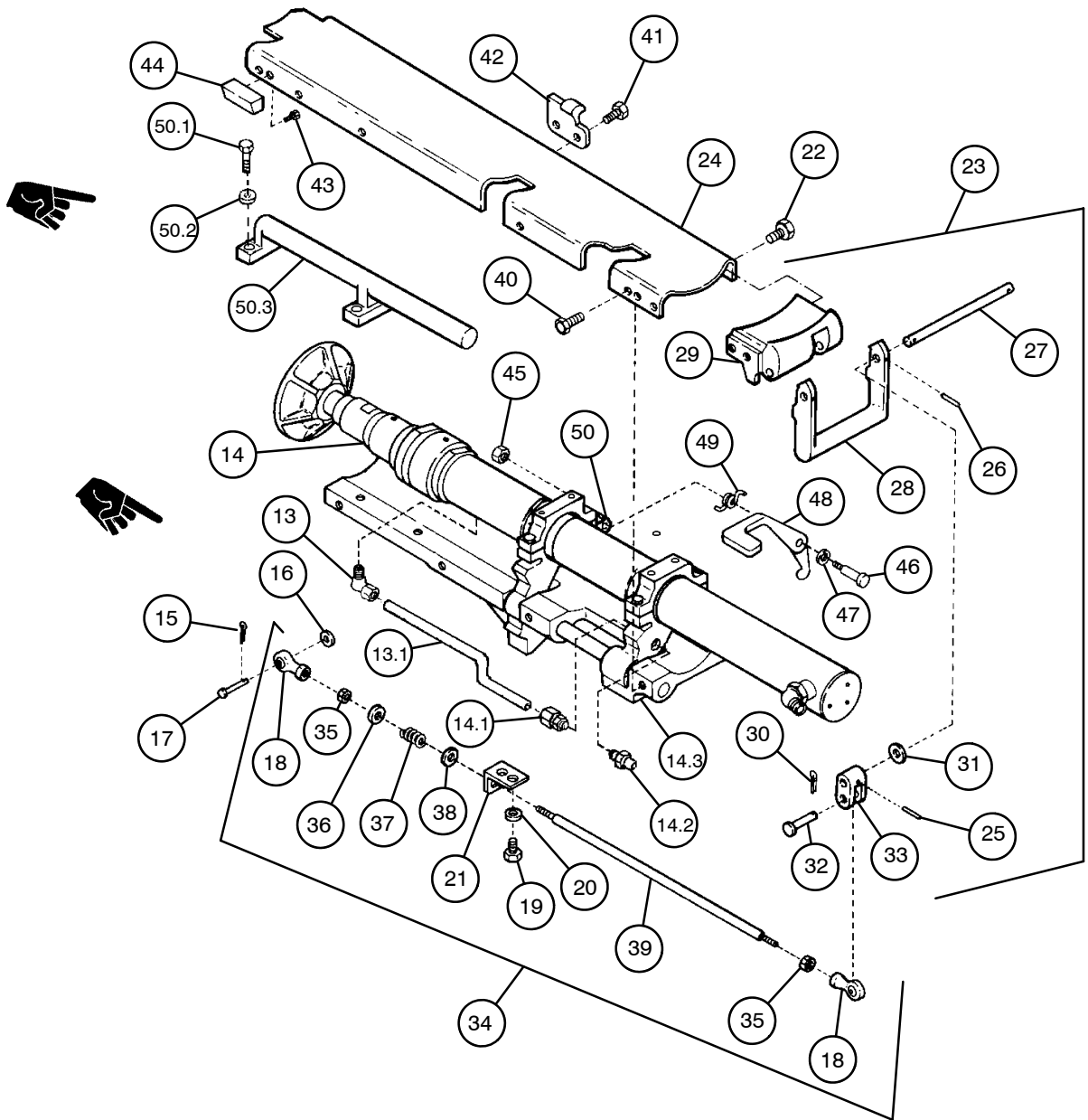
- 7 Install rammer handle (50.3), four flat washers (50.2), and four cap screws (50.1).
- 8 Apply sealing compound to threads of hex nut (45) and shoulder bolt (46). Install helical torsion spring (49), lock-release lever (48), flat washer (47), shoulder bolt (46), and hex nut (45) to front cylinder support (50). Torque bolt to 34–42 lb–ft (46–57 N·m).
- 9 Install mounting bracket (44) and two cap screws (43) to tray (24).
- 10 Apply sealing compound to threads of seven cap screws (40). Install tray (24), rammer latch (42), two cap screws (41), and seven cap screws (40). Torque cap screws (40) to 32–39 lb–ft (43–53 N·m).
- 11 Install angle bracket (21), flat washer (38), helical compression spring (37), flat washer (36), two hex nuts (35), and two rod end bearings (18) to rod (39).
- 12 Install rod group (34).
- 13 Install lever (33), straight headed pin (32), flat washer (31), and new cotter pin (30) on mounting bracket (29).

#### NOTE

If straight headless pin (27) is new from supply, perform step 14.

- 14 Drill 3 holes in straight headless pin (27) using handle (28) and lever (33) for pilot holes. Spring pins (26) inserted through handle (28) require a 1/8 inch (3.2 mm) hole. Spring pins (25) inserted through lever (33) require a 5/32 inch (3.7 mm) hole.
- 15 Install handle (28), straight headless pin (27), two new spring pins (26), and spring pins (25) on mounting bracket (29).
- 16 Install handle group (23) and four cap screws (22) on tray (24).
- 17 Install two flat washers (20) and two cap screws (19) on angle bracket (21).
- 18 Insert straight headed pin (17) into one rod end bearing (18).
- 19 Install flat washer (16) and new cotter pin (15) on straight headed pin (17).
- 20 Install adapter (14.2) and adapter (14.1) on rear cylinder support (14.3).
- 21 Install metallic tube (13.1), elbow (13) on cylinder assembly (14).





**NOTE**

Rammer support group is not shown for clarity.

## 7-2 RAMMER ASSEMBLY — CONTINUED

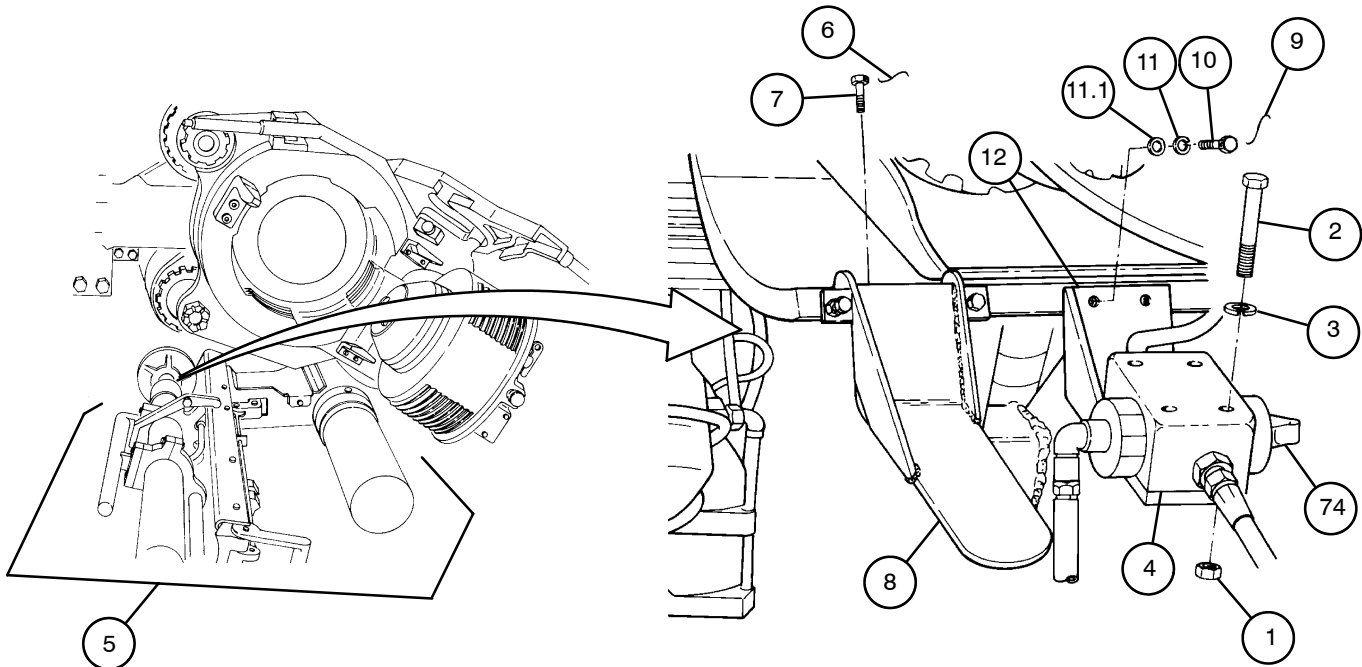
### e. Installation

- 1 Install angle bracket (12), two flat washers (11.1), two new lockwashers (11), and two cap screws (10). Do not tighten cap screws yet.

**CAUTION**

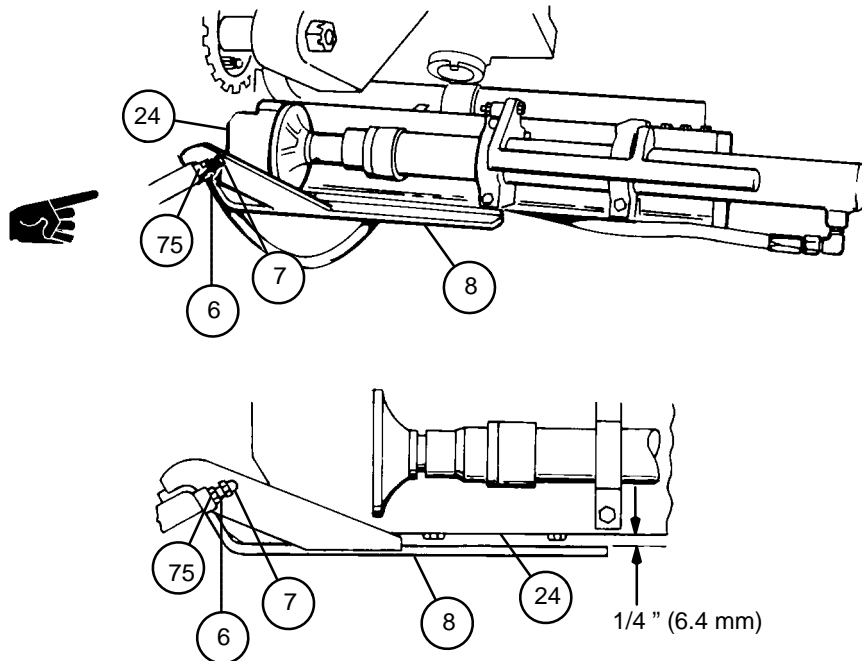
Do not spot paint bridge clamp or plunger as it could cause damage to equipment. Lubricate per TM 9-2350-311-10.

- 2 Adjust angle bracket (12) so that plunger (74) of blocking check valve (4) is depressed when rammer assembly (5) is in ram position, then tighten two cap screws (10). Torque two cap screws (10) to 35 to 45 ft-lb. Secure cap screws with new lockwire (9).
- 3 Install rammer mounting bracket (8) using two cap screws (7) and new lockwire (6).
- 4 Move rammer assembly (5) to retracted position.
- 5 Install blocking check valve (4), four new lockwashers (3), four cap screws (2), and four hex nuts (1).



**f. Adjustment**

- 1 Check clearance between tray (24) and rammer mounting bracket (8). Clearance should be approximately 1/4 inch (6.4 mm). Refer to steps 2 through 6 to adjust.
- 2 Loosen two hex nuts (75).
- 3 Remove lockwire (6) from two cap screws (7). Discard lockwire.
- 4 Turn two cap nuts (7) to adjust rammer mounting bracket (8) to required clearance of 0.25 inch (6.4 mm). ■
- 5 Tighten two hex nuts (75).
- 6 Check clearance to make sure it has stayed at 1/4 inch (6.4 mm) during tightening. Repeat adjustment if necessary.
- 7 Install new lockwire (6) on two cap nuts (7). ■



## 7-3 RAMMER RELIABILITY CHECKS

This task covers: a. Reliability checks b. Inspection

### INITIAL SETUP

Tools

Artillery and turret mechanic's tool kit  
(SC 4933-95-A12)

Materials/Parts

CLP (item 8, Appx D)

Lockwire (item 33, Appx G)

References

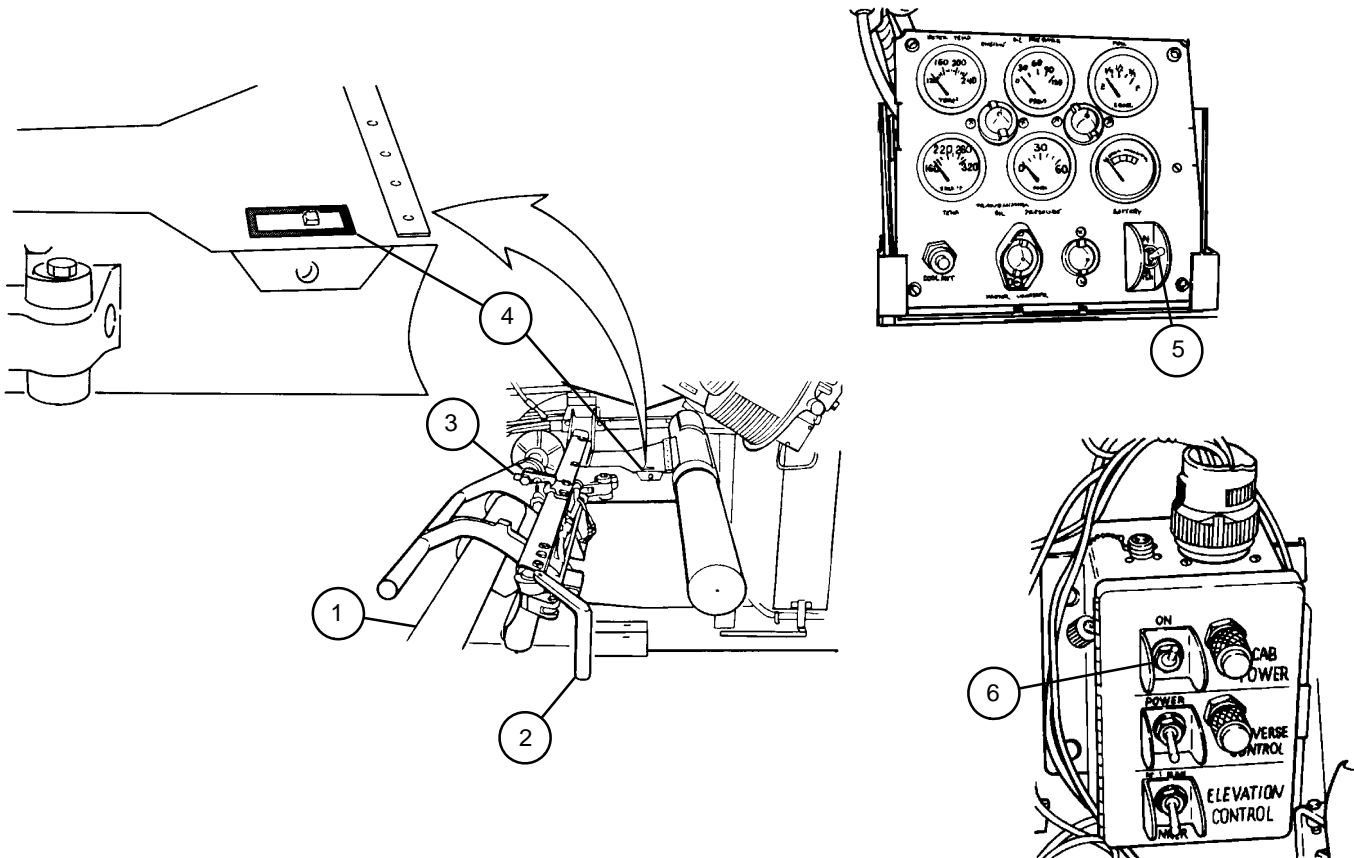
TM 9-2350-311-10

Equipment Condition

Breech opened (TM 9-2350-311-10)

#### a. Reliability Checks

- 1 Unlatch rammer assembly (1), position, and restow rammer.
  - (a) Check for operation of main release handle (2), support assemblies (3), and rammer safety pointer (4).
  - (b) Check for hose assemblies interfering with rammer support assembly during stowing.
  - (c) Position rammer for ramming operation.
  - (d) Turn on MASTER switch (5) and CAB POWER switch to ON (6).

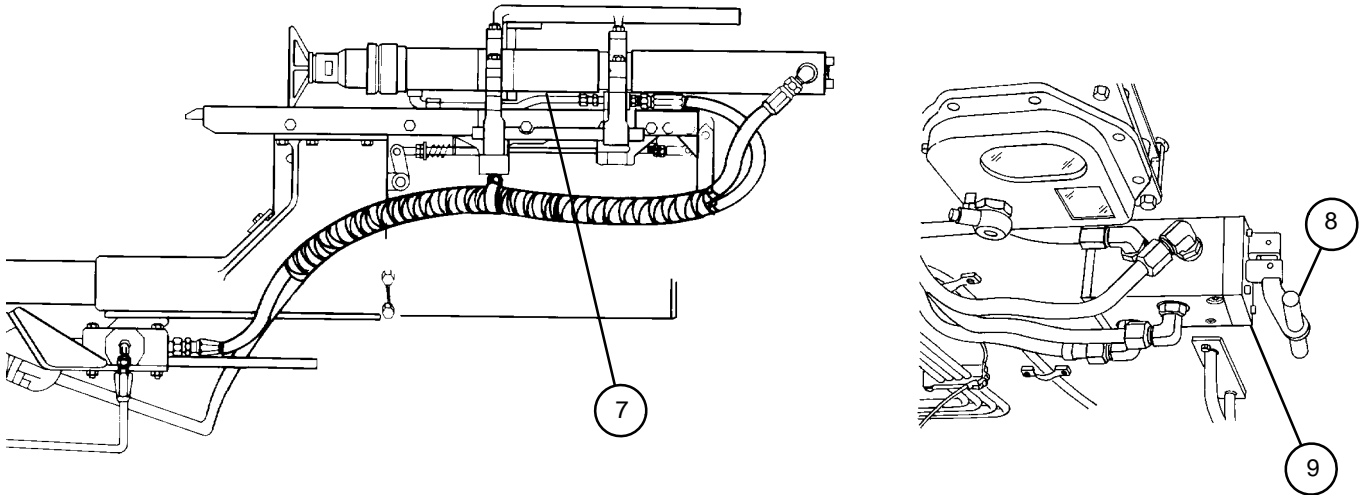


- Latch rammer cylinder (7) in upright position.

**CAUTION**

When exercising rammer, bring rammer to full extension slowly to avoid seal damage.

- Slowly depress control handle (8) on actuating valve (9). Rammer cylinder (7) should extend to full stroke. If rammer cylinder does not extend, follow inspection procedures (para 7-3b.).
- Check hoses, tubes, and connectors for oil leaks after operation of rammer. Repair or replace lines and tubes that are damaged.
- Restow rammer.



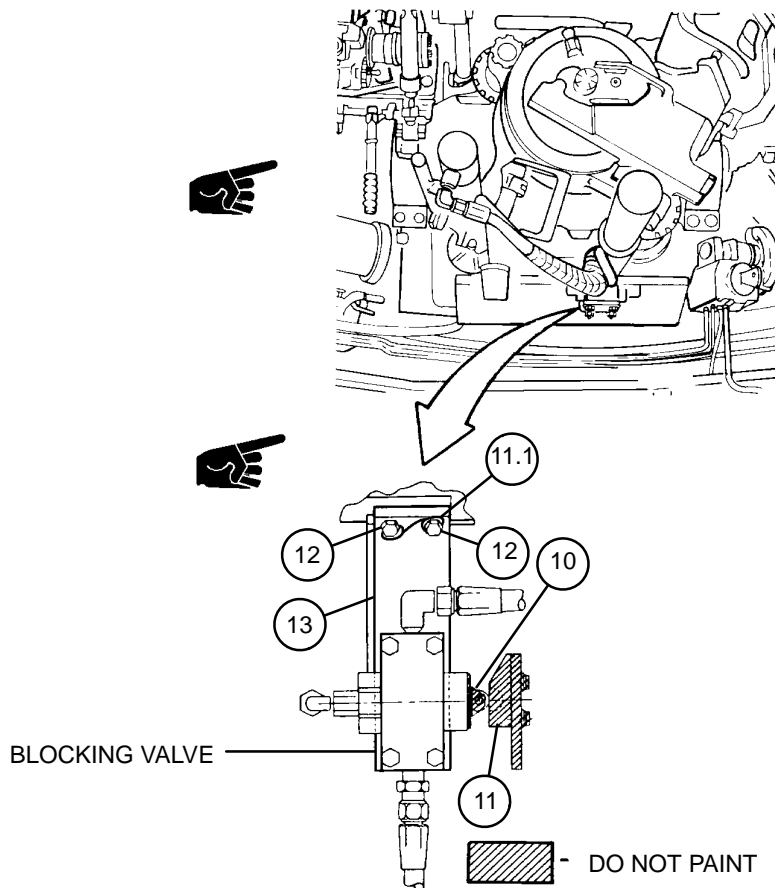
## 7-3 RAMMER RELIABILITY CHECKS — CONTINUED

### b. Inspection

**CAUTION**

- Do not paint plunger or bridge clamp on rammer valve as it could cause damage to equipment. Lubricate per TM 9-2350-311-10.
- Make sure that rammer actuating lever is in inactive (out) position before placing rammer assembly in upright position to avoid damage to equipment.

- 1 Set the rammer in ram position.
- 2 Visually check alinement of plunger (10) with bridge clamp (11). If plunger is disengaged remove and discard lockwire (11.1), loosen two cap screws (12). Slide angle bracket (13) in direction required to engage with plunger. Tighten two cap screws (12) and torque to 35 to 45 ft-lbs. Secure two cap screws (12) with new lockwire (11.1).
- 3 Check operation of rammer (para 7-3a.).



## 7-4 ACTUATING VALVE

This task covers: a. Removal b. Installation

### INITIAL SETUP

#### Tools

Artillery and turret mechanic's tool kit  
(SC 5180-95-CL-A12)

Utility pail (item 7, Appx H)

#### Materials/Parts

Caps and plugs (item 7, Appx D)

Lockwashers (2) (item 95, Appx G)

#### Equipment Condition

Discharge hydraulic pressure (para 6-3)

### a. Removal

#### CAUTION

All hydraulic lines and ports must be capped to prevent contaminants from entering the hydraulic system and causing internal damage to hydraulic components.

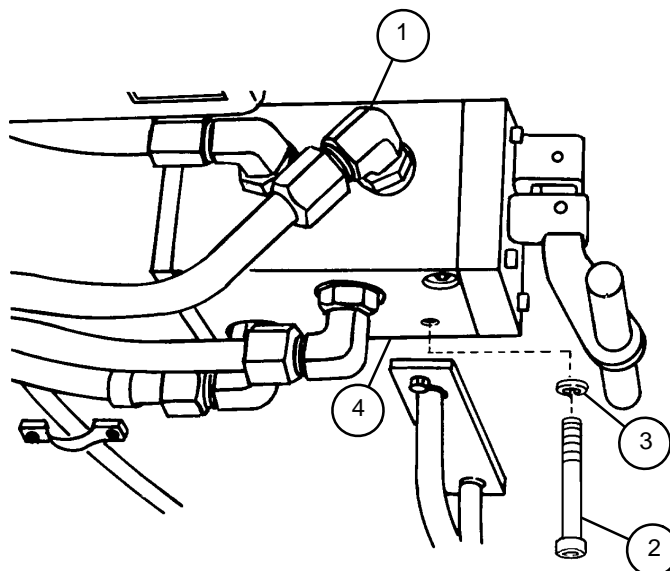
#### NOTE

- Have a utility pail available to catch hydraulic fluid from valve and connectors.
- Dispose of hydraulic fluid in accordance with local regulations.

- 1 Disconnect four tubes (1).
- 2 Remove two cap screws (2), two lockwashers (3), and actuating valve assembly (4). Discard lockwashers.

### b. Installation

- 1 Install actuating valve assembly (4) using two new lockwashers (3) and two cap screws (2).
- 2 Connect four tubes (1).







## CHAPTER 8

### CAB ELECTRICAL SYSTEM

#### GENERAL

This chapter describes unit level maintenance procedures for the cab electrical system. Step-by-step procedures are provided for maintaining electrical leads and harnesses, electrical components, and the intercommunications system.

<u>CONTENTS</u>	<u>Page</u>
Section I. ELECTRICAL LEADS AND HARNESSSES	
8-1 WIRING HARNESS AND CABLE REPAIR .....	8-2
8-2 GUNNER'S SELECTOR SWITCH BOX WIRING HARNESS .....	8-12
8-3 PANORAMIC TELESCOPE TO DOME LIGHT LEAD ASSEMBLY .....	8-16
8-4 CAB POWER LEAD ASSEMBLY .....	8-24
8-5 POWER RELAY BOX TO PUMP MOTOR LEAD ASSEMBLY .....	8-28
8-6 POWER RELAY BOX TO PRESSURE SWITCH WIRING HARNESS .....	8-31
8-7 CAB TRAVERSING MECHANISM HARNESS .....	8-34
8-8 GUNNER'S ELEVATION CONTROL SWITCH LEAD ASSEMBLY .....	8-38
8-9 NBC POWER LEAD ASSEMBLY .....	8-42
8-10 NBC GROUND LEAD .....	8-46
Section II. COMPONENT MAINTENANCE	
8-11 DOME LIGHT ASSEMBLIES .....	8-47
8-12 GUNNER'S SELECTOR SWITCH BOX ASSEMBLY .....	8-52
8-13 POWER RELAY BOX ASSEMBLY .....	8-60
Section III. INTERCOMMUNICATIONS SYSTEM	
8-14 POWER RELAY BOX TO INTERCOM POWER SUPPLY LEAD ASSEMBLY .....	8-67
8-15 POWER SYSTEM WIRING HARNESS (INTERCOM) .....	8-70
8-16 AMPLIFIER AND CONTROL BOX .....	8-77

## Section I. ELECTRICAL LEADS AND HARNESES

### 8–1 WIRING HARNESS AND CABLE REPAIR

- This task covers: This task covers disassembly and assembly of the following:
- a. Cable, Wire, Receptacle and Plug Identifiers
  - b. Female-Type Panel Mounting Receptacle
  - c. Male-Type Panel Mounting Receptacle
  - d. Female-Type Panel Mounting Receptacle with Ridged Locking Nut
  - e. Male-Type Panel Mounting Receptacle with Ridged Locking Nut
  - f. Female-Type Plug with Ridged Locking Nut
  - g. Male-Type Plug with Ridged Locking Nut
  - h. Terminal-Type Cable Connector
  - i. Female-Type Cable Connector with Washer
  - j. Male-Type Cable Connector with Washer
  - k. Female-Type Cable Connector with Sleeve

#### **INITIAL SETUP**

##### Tools

Artillery and turret mechanic's tool kit  
 Electrical connector tool kit (item 14, Appx H)  
 Soldering gun (item 12, Appx H)  
 Soldering torch kit (item 13, Appx H)

Flux (item 15, Appx D)  
 Rosin core solder (item 34, Appx D)  
 Tag, marking (item 36, Appx D)  
 Tape, black (electrical) (item 39, Appx D)

##### Equipment Condition

Disconnect batteries (TM 9–2350–311–10)

##### Materials/Parts

Electrical connectors

#### **WARNING**

Disconnect battery ground cable at battery terminal when working on any harness in this section. Serious burns and electrical shock can result from failure to disconnect battery ground cable.

#### **NOTE**

When removing more than one wire from a multiple wire receptacle, record which line was removed from which pin hole.

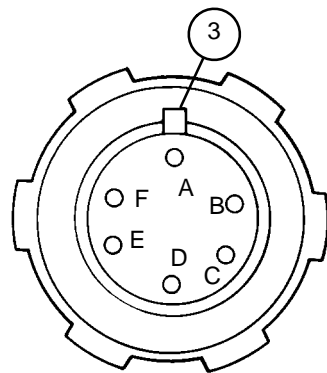
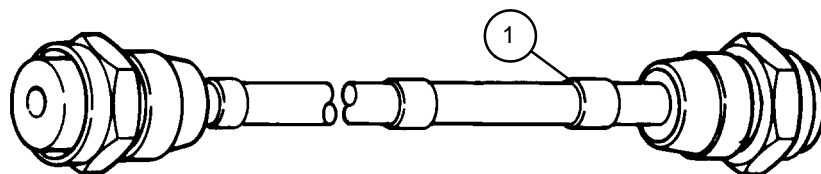
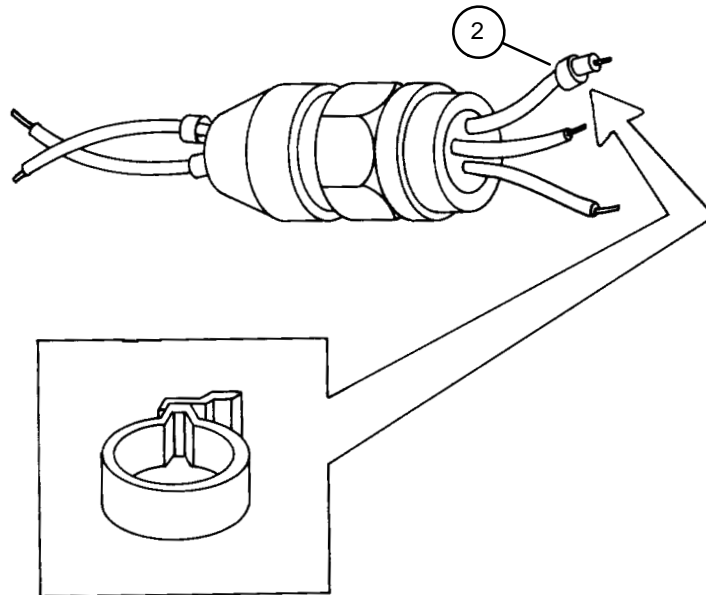
#### **a. Cable, Wire, Receptacle and Plug Identifiers**

#### **NOTE**

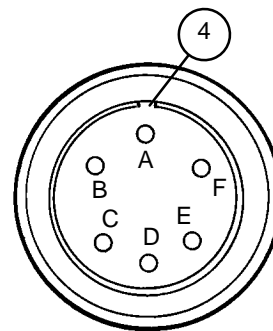
Before proceeding, see instructions on using soldering gun and soldering torch kit (para 2–16).

- 1 Cable identifiers (1) are aluminum tags attached to cables. These tags are embossed with the cable identification number. Cable identifier numbers are shown on the system's wiring diagram.
- 2 Wire identifiers (2) are embossed with the same individual wire number. Wire identifier numbers are also shown on system's wiring diagram.

- 3 If cables or wires are replaced, remove tags from old wire and place them on new wire.
- 4 All pins (male connectors) and sockets (female connectors) in receptacles and plugs are identified by alphabetic code. Coded identification starts at the connector key (3) or groove (4).
  - (a) Male connectors: identifying letters run clockwise.
  - (b) Female connectors: identifying letters run counterclockwise.



MALE CONNECTOR



FEMALE CONNECTOR

---

## 8-1 WIRING HARNESS AND CABLE REPAIR — CONTINUED

---

### b. Female-Type Panel Mounting Receptacle

#### 1 Disassembly

- (a) Push socket contacts (1) out through rear of insert (2) with pin extractor.
- (b) Unsolder cable leads (3) from solder wells of socket contacts (1).
- (c) Slide insert (2) out through rear of shell (4).

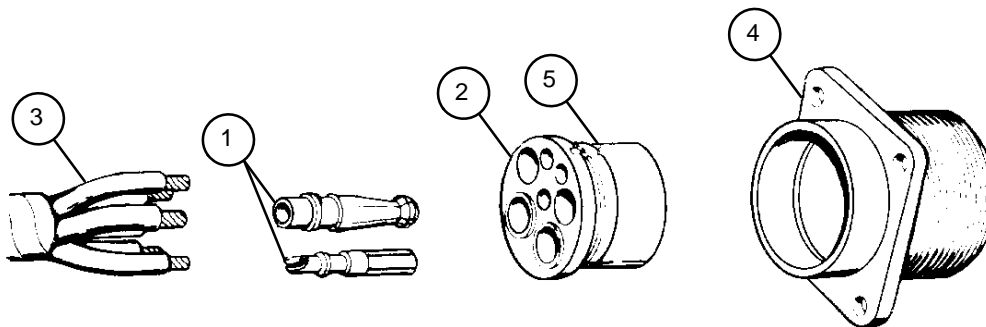
#### 2 Assembly

- (a) Strip cable insulation equal to depth of solder wells of socket contacts (1).

#### NOTE

Use rosin core solder only. For soldering instructions, refer to para 2-16.

- (b) Insert cable leads (3) into solder wells of socket contacts (1) and solder.
- (c) Push insert (2) into shell (4) from rear until seated. Groove (5) in insert (2) must be aligned with guide in shell (4) to ensure proper fit.
- (d) Push socket contacts (1) into insert (2) from rear until seated.
- (e) Tape wire as required.



**c. Male-Type Panel Mounting Receptacle****1 Disassembly**

- (a) Push pin contacts (1) out through rear of insert (2) with pin extractor.
- (b) Unsolder cable leads (3) from solder wells of pin contacts (1).
- (c) Slide insert (2) out through rear of shell (4).

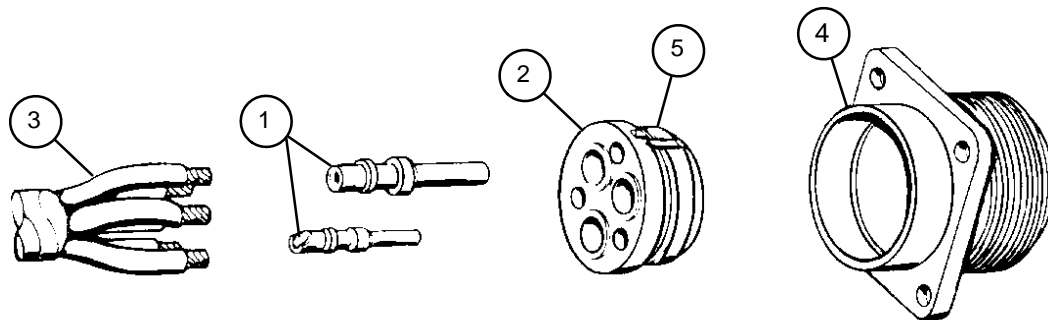
**2 Assembly**

- (a) Strip cable insulation equal to depth of solder wells of pin contacts (1).

**NOTE**

Use rosin core solder only. For soldering instructions, refer to para 2-16.

- (b) Insert cable leads (3) into solder wells of pin contacts (1) and solder.
- (c) Push insert (2) into shell (4) from rear until seated. Groove (5) in insert (2) must be aligned with guide in shell (4) to ensure proper fit.
- (d) Push pin contacts (1) into insert (2) from rear until seated.
- (e) Tape wire as required.



**8-1 WIRING HARNESS AND CABLE REPAIR — CONTINUED**

**d. Female-Type Panel Mounting Receptacle with Ridged Locking Nut**

**1 Disassembly**

- (a) Unscrew nut (1) from shell (2) and slide back on cable leads (3).
- (b) Slide grommet (4) back on cable leads (3).
- (c) Push socket contacts (5) out through rear of insert (6) with pin extractor.
- (d) Slide insert (6) out through rear of shell (2).
- (e) Unsolder cable leads (3) from solder wells of socket contacts (5).

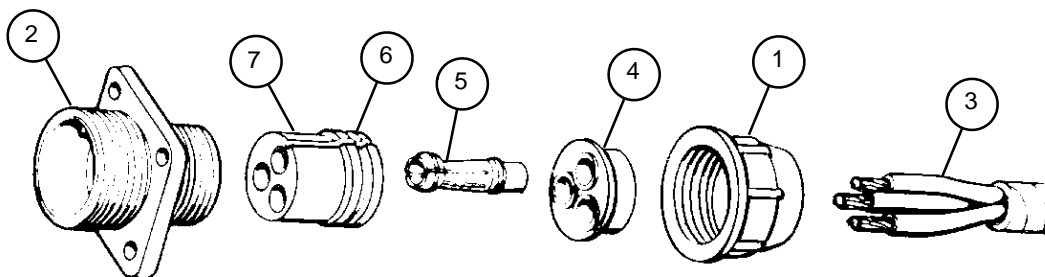
**2 Assembly**

- (a) Strip cable insulation equal to depth of solder wells of socket contacts (5).
- (b) Slide nut (1) over cable leads (3).
- (c) Slide grommet (4) over cable leads (3).

**NOTE**

Use rosin core solder only. For soldering instructions, refer to para 2-16.

- (d) Insert cable leads (3) into solder wells of socket contacts (5) and solder.
- (e) Push insert (6) into shell (2) from rear until seated. Groove (7) in insert (6) must be aligned with guide in shell (2) to ensure proper fit.
- (f) Push socket contacts (5) into insert (6) from rear until seated.
- (g) Push grommet (4) down cable leads (3) and over solder wells of socket contacts (5).
- (h) Screw nut (1) onto shell (2).
- (i) Tape wire as required.



### e. Male-Type Panel Mounting Receptacle with Ridged Locking Nut

#### 1 Disassembly

- (a) Unscrew nut (1) from shell (2) and slide back on cable leads (3).
- (b) Push grommet (4) back on cable leads (3).
- (c) Push pin contacts (5) out through rear of insert (6) with pin extractor.
- (d) Slide insert (6) out through rear of shell (2).
- (e) Unsolder cable leads (3) from solder wells of pin contacts (5).

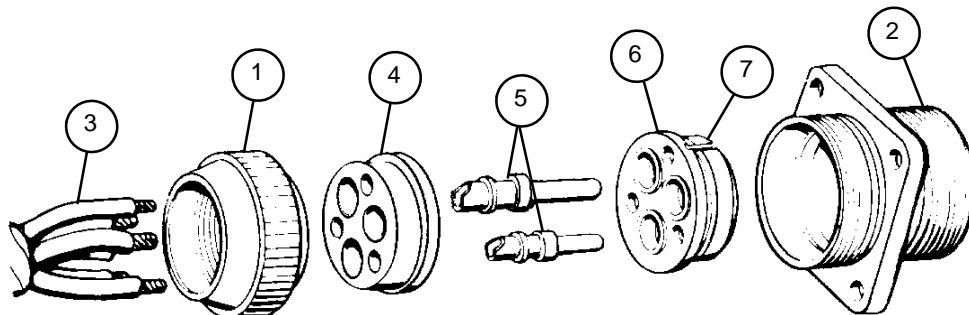
#### 2 Assembly

- (a) Strip cable insulation equal to depth of solder wells of pin contacts (5).
- (b) Slide nut (1) over cable leads (3).
- (c) Slide grommet (4) over cable leads (3).

#### NOTE

Use rosin core solder only. For soldering instructions, refer to para 2-16.

- (d) Insert cable leads (3) into solder wells of pin contacts (5) and solder.
- (e) Push insert (6) into shell (2) from rear until seated. Groove (7) in insert (6) must be aligned with guide in shell (2) to ensure proper fit.
- (f) Push pin contacts (5) into insert (6) from rear until seated.
- (g) Push grommet (4) down cable leads (3) and over solder wells of pin contacts (5).
- (h) Screw nut (1) onto shell (2).



**8-1 WIRING HARNESS AND CABLE REPAIR — CONTINUED**

**f. Female-Type Plug with Ridged Locking Nut**

**1 Disassembly**

- (a) Unscrew nut (1) from shell (2) and slide back on cable leads (3).
- (b) Slide grommet (4) back on cable leads (3).
- (c) Slide coupling nut (5) off shell (2).
- (d) Push socket contacts (6) out through rear of insert (7) with pin extractor.
- (e) Slide insert (7) out through rear of shell (2).
- (f) Unsolder cable leads (3) from solder wells of socket contacts (6).

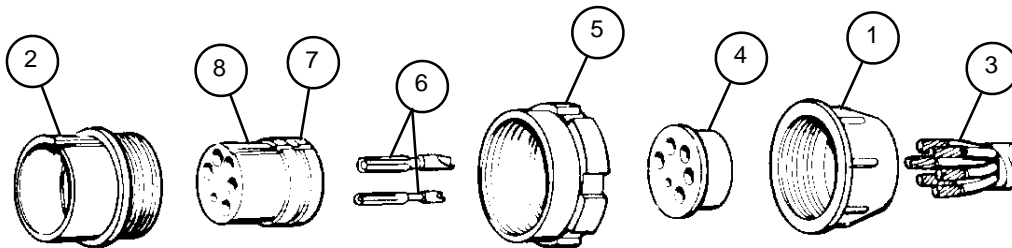
**2 Assembly**

- (a) Strip cable insulation equal to depth of solder wells of socket contacts (6).
- (b) Slide nut (1) over cable leads (3).
- (c) Slide grommet (4) over cable leads (3).

**NOTE**

Use rosin core solder only. For soldering instructions, refer to para 2-16.

- (d) Insert cable leads (3) into solder wells of socket contacts (6) and solder.
- (e) Push insert (7) into shell (2) from rear until seated. Groove (8) in insert (7) must be aligned with guide in shell (2) to ensure proper fit.
- (f) Push socket contacts (6) into insert (7) from rear until seated.
- (g) Slide coupling nut (5) onto shell (2).
- (h) Push grommet (4) down cable leads (3) and over solder wells of socket contacts (6).
- (i) Screw nut (1) onto shell (2).





**g. Male-Type Plug with Ridged Locking Nut****1 Disassembly**

- (a) Unscrew nut (1) from shell (2) and slide back on cable leads (3).
- (b) Slide grommet (4) back on cable leads (3).
- (c) Slide coupling nut (5) off shell (2).
- (d) Push pin contacts (6) out through rear of insert (7) with pin extractor.
- (e) Slide insert (7) out through rear of shell (2).
- (f) Unsolder cable leads (3) from solder wells of pin contacts (6).

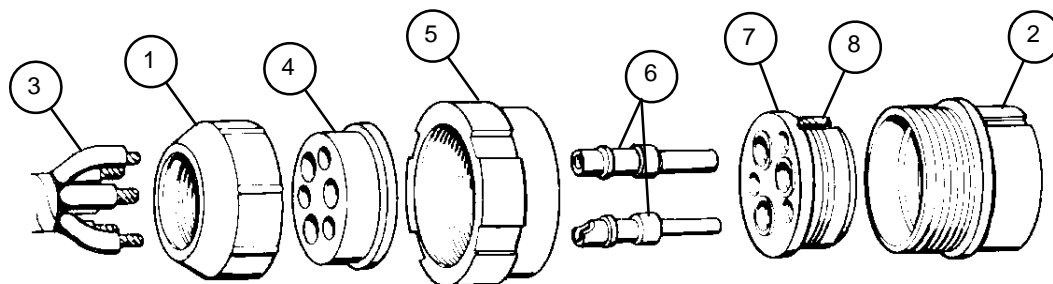
**2 Assembly**

- (a) Strip cable of insulation equal to depth of solder wells of pin contacts (6).
- (b) Slide nut (1) over cable leads (3).
- (c) Slide grommet (4) over cable leads (3).

**NOTE**

Use rosin core solder only. For soldering instructions, refer to para 2-16.

- (d) Insert cable leads (3) into solder wells of pin contacts (6) and solder.
- (e) Push insert (7) into shell (2) from rear until seated. Groove (8) in insert (7) must be aligned with guide in shell (2) to ensure proper fit.
- (f) Push pin contacts (6) into insert (7) from rear until seated.
- (g) Slide coupling nut (5) onto shell (2).
- (h) Push grommet (4) down cable leads (3) and over solder wells of pin contacts (6).
- (i) Screw nut (1) onto shell (2).
- (j) Tape wire as required.



---

## 8-1 WIRING HARNESS AND CABLE REPAIR — CONTINUED

---

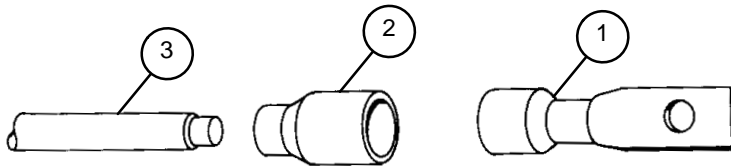
### h. Terminal-Type Cable Connectors

1 Disassembly

Cut and discard connector.

2 Assembly

- (a) Strip cable insulation equal to depth of terminal (1) well.
- (b) Slide insulator (2) over cable (3).
- (c) Insert cable (3) into terminal (1) well and crimp.
- (d) Slide insulator (2) over crimped end of terminal (1).



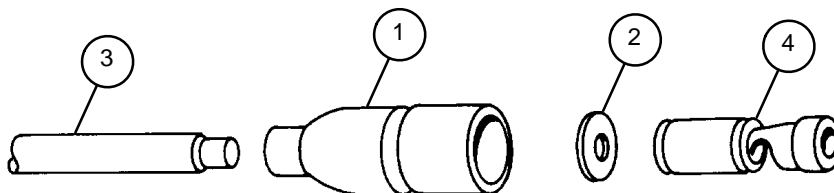
### i. Female-Type Cable Connector with Washer

1 Disassembly

Cut and discard connector.

2 Assembly

- (a) Strip cable insulation approximately 1/8 inch (3.2 mm).
- (b) Slide shell (1) and washer (2) over cable (3).
- (c) Place cable (3) in cylinder end of terminal (4) and crimp.
- (d) Slide shell (1) and washer (2) over terminal (4).

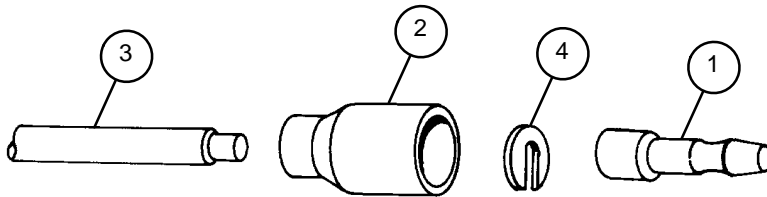


**j. Male-Type Cable Connector with Washer****1 Disassembly**

Cut and discard connector.

**2 Assembly**

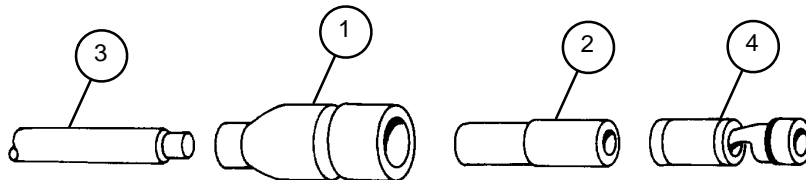
- (a) Strip cable insulation equal to depth of terminal (1) well.
- (b) Slide shell (2) over cable (3).
- (c) Insert cable (3) into terminal (1) well and crimp.
- (d) Place C-washer (4) over cable (3) at crimped junction and slide shell (2) over C-washer and terminal (1).

**k. Female-Type Cable Connector with Sleeve****1 Disassembly**

Cut and discard connector.

**2 Assembly**

- (a) Strip cable insulation approximately 1/8 inch (3.2 mm).
- (b) Slide shell (1) and sleeve (2) over cable (3).
- (c) Place cable (3) in cylinder end of terminal (4) and crimp.
- (d) Slide shell (1) and sleeve (2) over terminal (4).



---

## 8-2 GUNNER'S SELECTOR SWITCH BOX WIRING HARNESS

---

- This task covers:
- |            |                         |
|------------|-------------------------|
| a. Removal | b. Disassembly/Assembly |
| c. Testing | d. Installation         |
- 

### **INITIAL SETUP**

#### Test Equipment

Multimeter (item 6, Appx H)

#### Tools

Artillery and turret mechanic's tool kit  
(SC 5180-95-CL-A12)

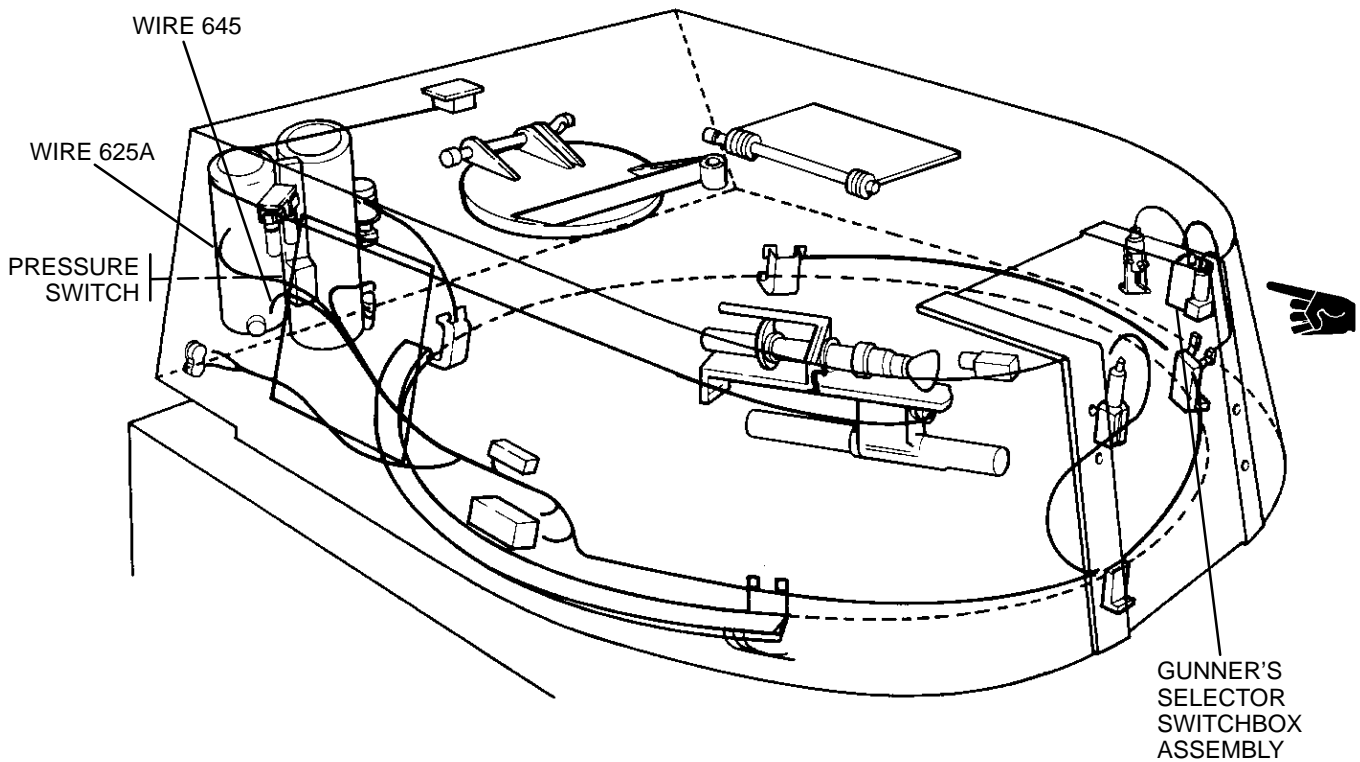
#### Materials/Parts

Lockwashers (3) (item 86, Appx G)  
Tape, black (electrical) (item 39, Appx D)

#### Equipment Condition

Disconnect batteries (TM 9-2350-311-20-1)

---

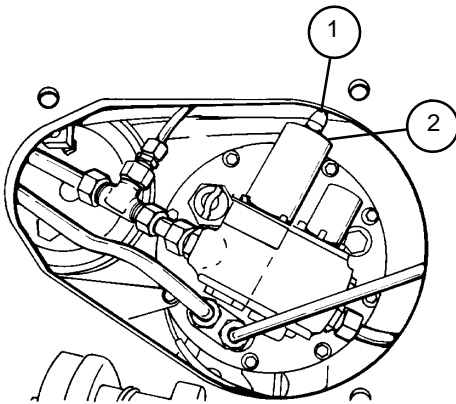


**a. Removal**

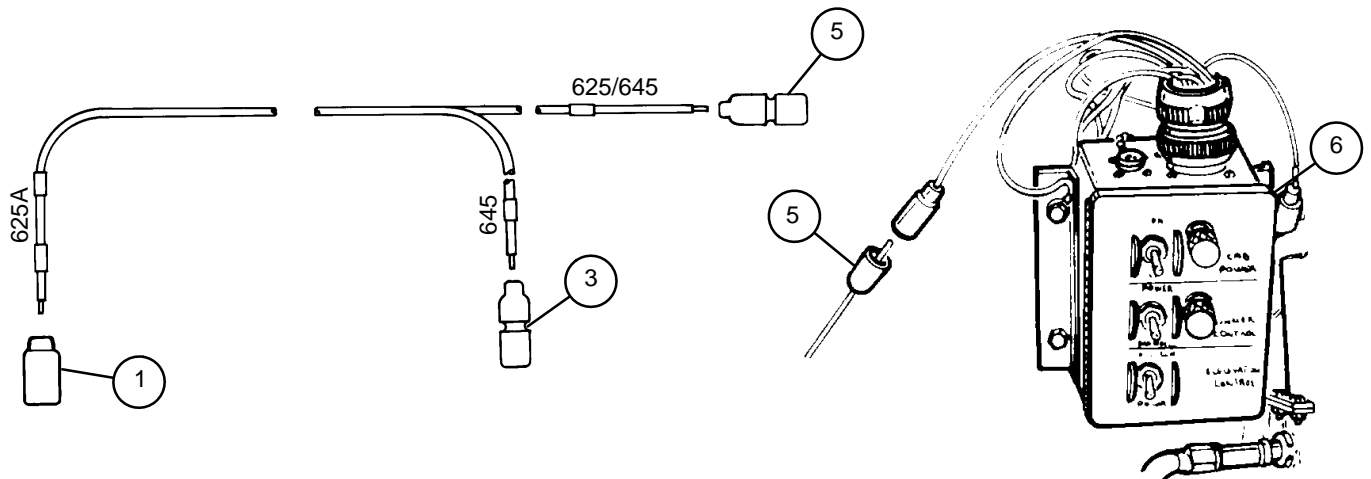
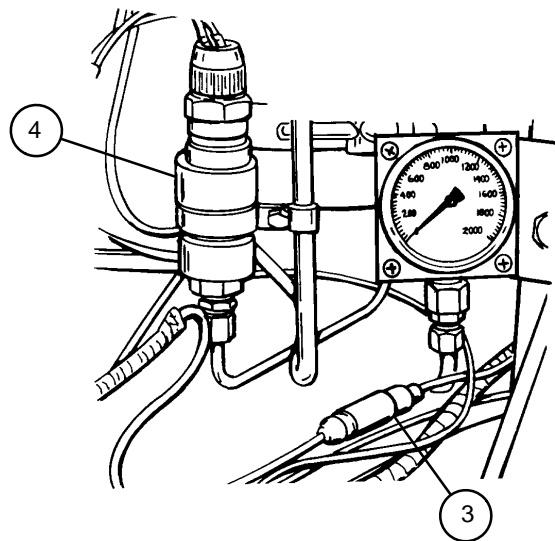
**NOTE**

Tape must be removed from wiring bundle to remove any specific wiring harness. Apply tape after assembly.

- 1 Disconnect connector (1), wire 625A, from power pack solenoid (2).
- 2 Disconnect connector (3), wire 645, at quick-disconnect from pressure switch (4).
- 3 Disconnect connector (5), wire 625A/645, at quick-disconnect from gunner's selector switch box assembly (6).



M109A2/M109A3 HOWITZER



---

## 8-2 GUNNER'S SELECTOR SWITCH BOX WIRING HARNESS — CONTINUED

---

### a. Removal — Continued

- 4 Remove three cap screws (7), three flat washers (8), three plastic attaching straps (9), and three lockwashers (10) securing gunner's selector switch box wiring harness (11) to vehicle. Discard lockwashers.

### b. Disassembly/Assembly

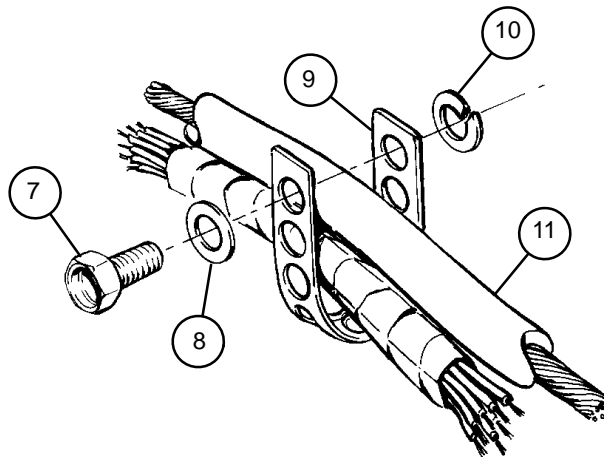
See repair procedures for harnesses, plugs, and terminals (para 8-1).

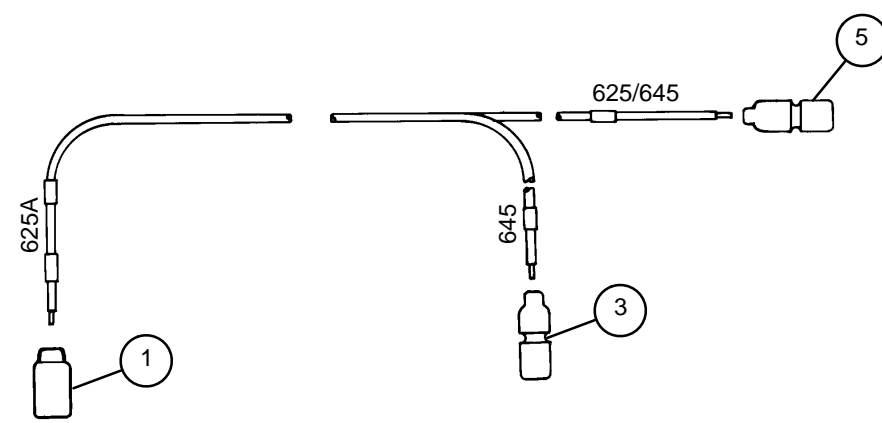
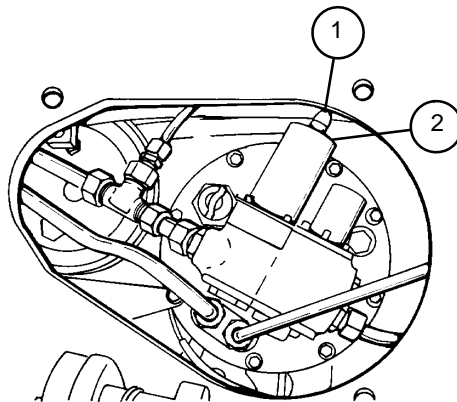
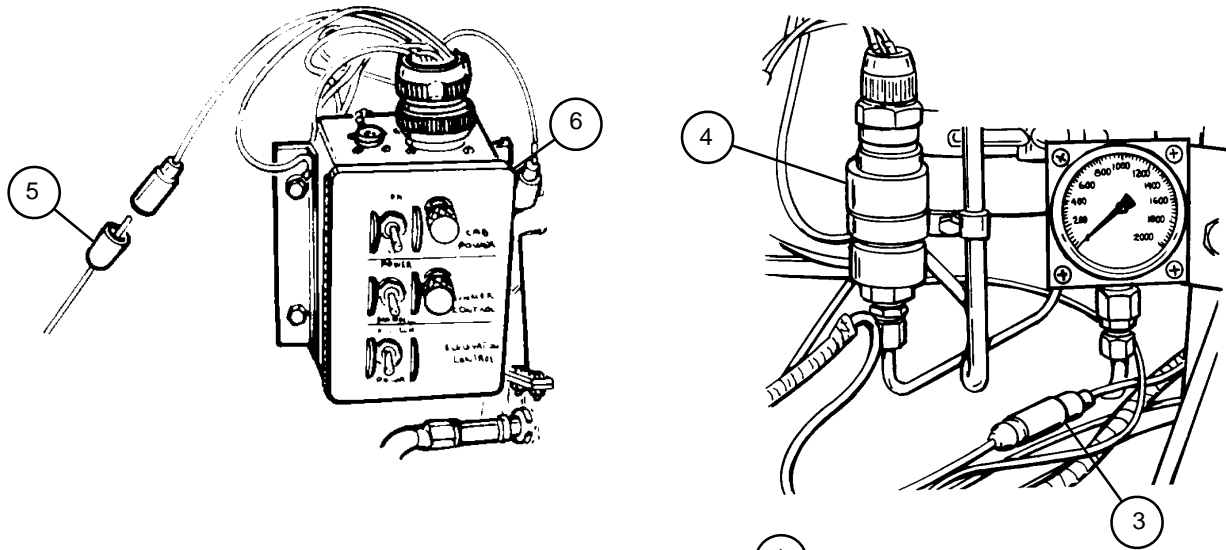
### c. Testing

Using multimeter, test gunner's selector switch box wiring harness for continuity through all plugs and connectors.

### d. Installation

- 1 Secure gunner's selector switch box wiring harness (11) to vehicle using three new lockwashers (10), three plastic attaching straps (9), three flat washers (8), and three cap screws (7).
- 2 Connect connector (5), wire 625/645, at quick-disconnect from gunner's selector switch box assembly (6).
- 3 Connect connector (3), wire 645, at quick-disconnect from pressure switch (4).
- 4 Connect connector (1), wire 625A, to power pack solenoid (2)





---

## 8-3 PANORAMIC TELESCOPE TO DOME LIGHT LEAD ASSEMBLY

---

- This task covers:
- |                 |                |
|-----------------|----------------|
| a. Removal      | b. Disassembly |
| c. Testing      | d. Assembly    |
| e. Installation |                |

### INITIAL SETUP

Test Equipment

Multimeter (item 6, Appx H)

Tools

Artillery and turret mechanic's tool kit  
(SC 5180-95-CL-A12)

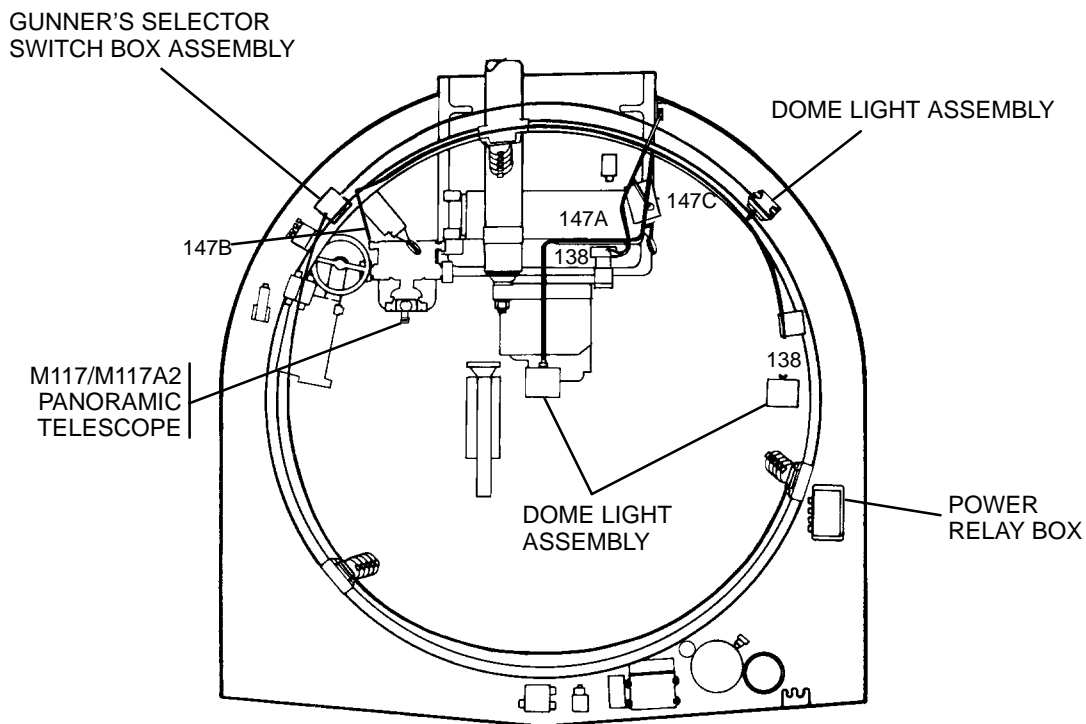
Materials/Parts

Lockwashers (12) (item 86, Appx G)  
Self-locking nuts (3) (item 184, Appx G)  
Tape, black (electrical) (item 39, Appx D)

Equipment Condition

Disconnect batteries (TM 9-2350-311-10)

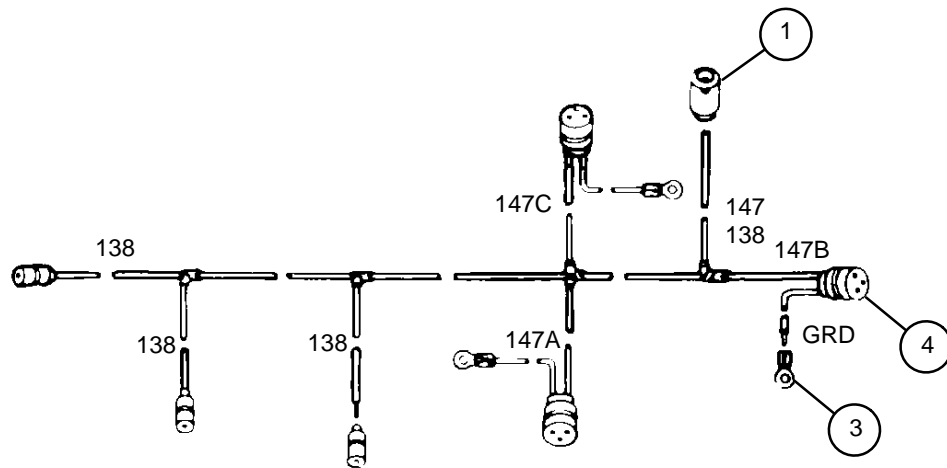
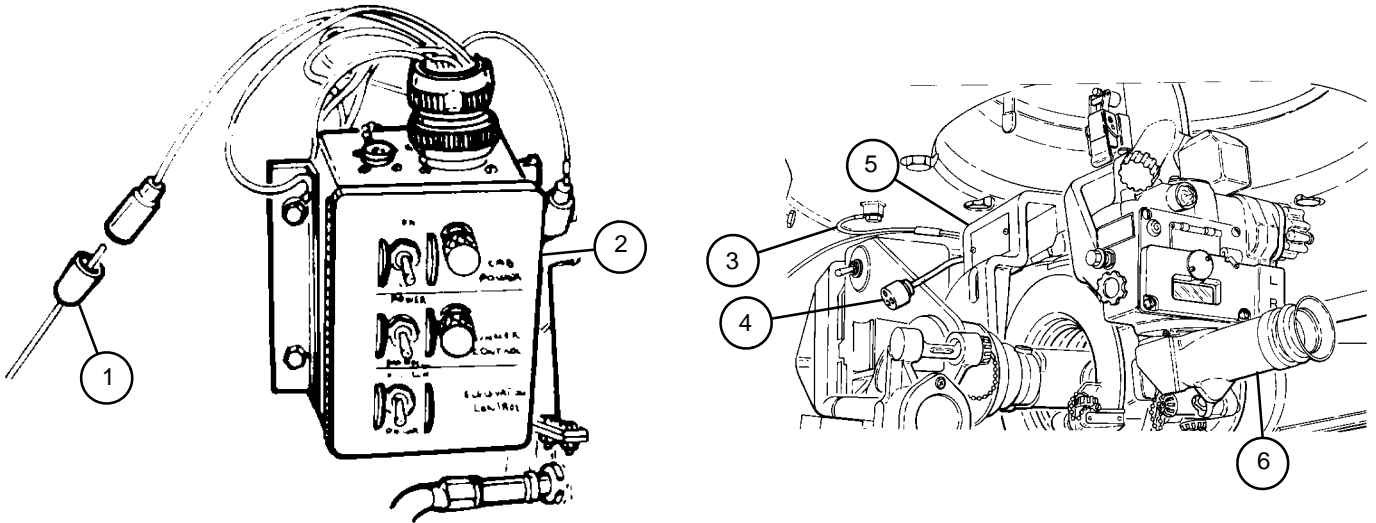
---





a. Removal

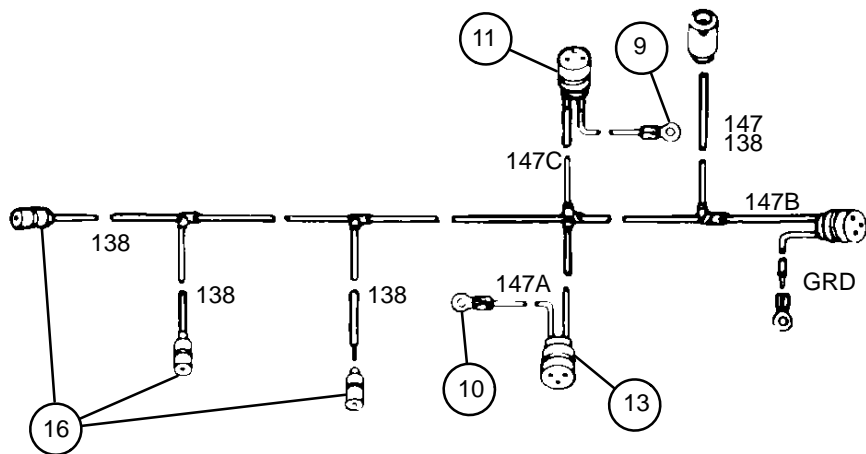
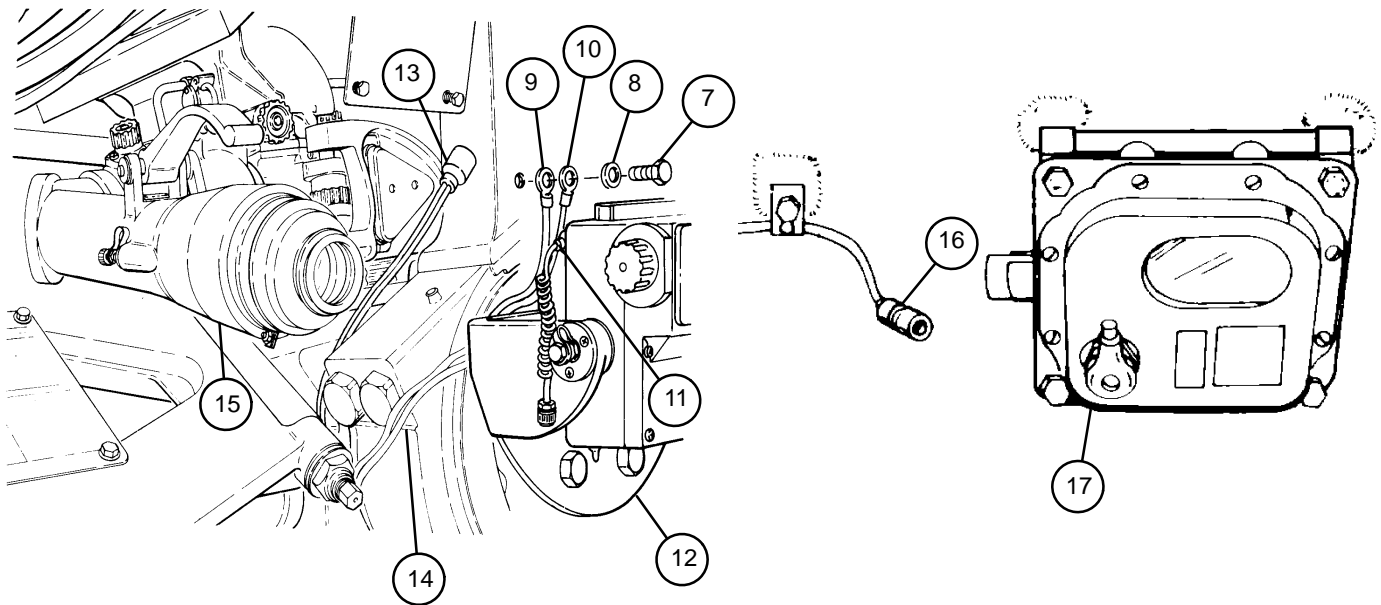
- 1 Disconnect connector (1), wire 138/147, at quick-disconnect on gunner's selector switch box assembly (2).
- 2 Disconnect terminal (3) by removing hex nut and flat washer (not shown) from roof of cab.
- 3 Disconnect connector (4), wire 147B, from M145/M14A1 telescope mount (5) for the M117/M117A2 panoramic telescope (6).



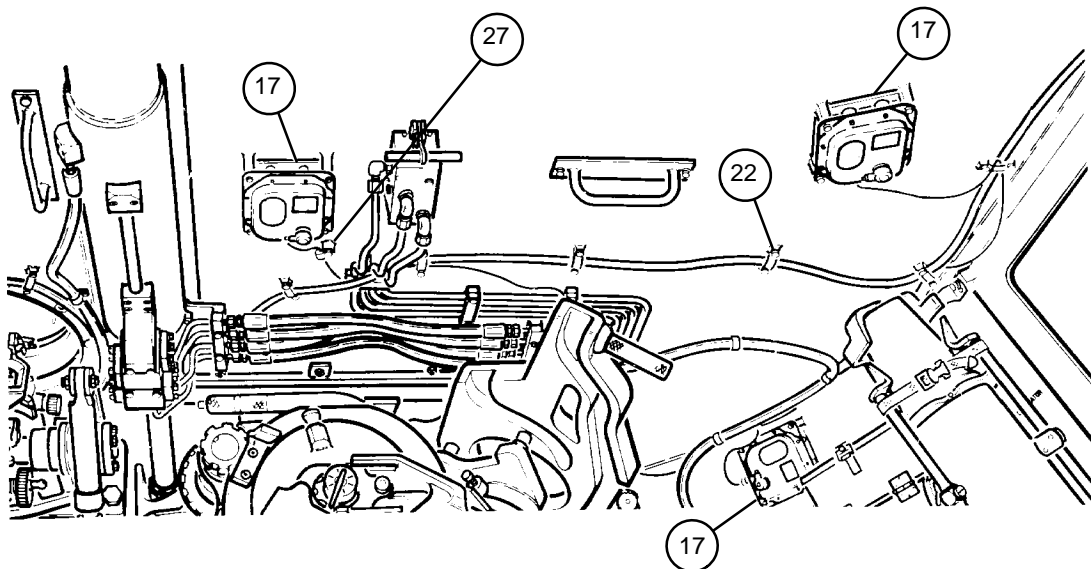
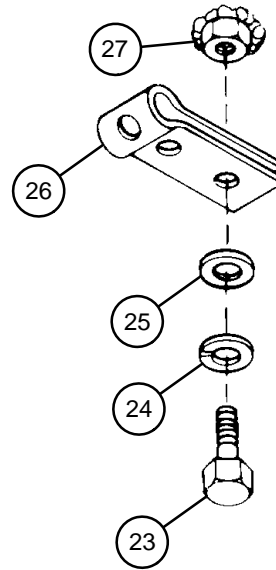
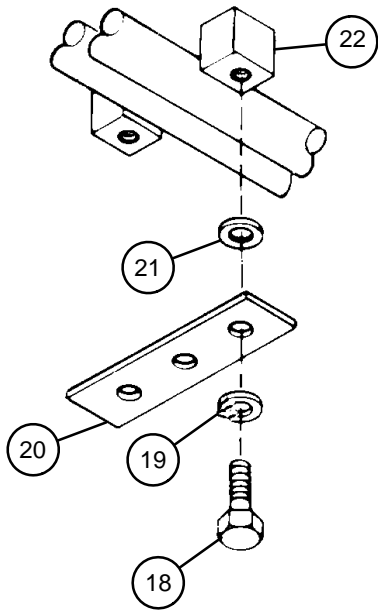
## 8-3 PANORAMIC TELESCOPE TO DOME LIGHT LEAD ASSEMBLY — CONTINUED

### a. Removal — Continued

- 4 Remove hex cap screw (7) and flat washer (8) to disconnect terminal (9) at ground lead wire 147A and terminal (10) at ground lead wire 147C.
- 5 Disconnect connector (11), wire 147C, from M15 elevation quadrant (12).
- 6 Disconnect connector (13), wire 147A, from M146 mount (14) for M118A2/M118A3 elbow telescope (15).
- 7 Disconnect three connectors (16), wire 138, from three dome light assemblies (17).



- 8 Remove four cap screws (18), four lockwashers (19), two plastic attaching straps (20), and four flat washers (21) from channel-type attachment assembly (22). Discard lockwashers.
- 9 Remove eight cap screws (23), eight lockwashers (24), eight flat washers (25), and four plastic attaching straps (26) from welded hex nut attachment assemblies (27). Discard lockwashers.



## 8-3 PANORAMIC TELESCOPE TO DOME LIGHT LEAD ASSEMBLY — CONTINUED

### b. Disassembly

- 1 Remove three self-locking nuts (28), three flat washers (29), three plastic attaching straps (30), three flat washers (31), and three cap screws (32) from harness assembly. Discard self-locking nuts.
- 2 Remove tape (33) to separate panoramic telescope to dome light lead assembly (34) from power lead assembly (35) and power system wiring harness (intercom) (36).
- 3 Repair or replace electrical leads or connectors as necessary (para 8-1).

### c. Testing

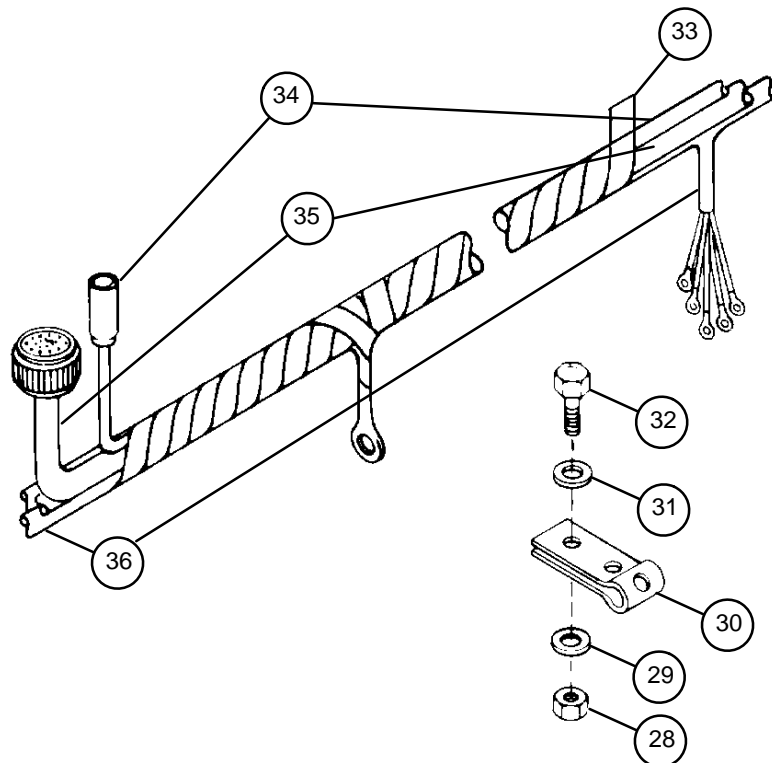
Using multimeter, test panoramic telescope to dome light lead assembly for continuity through all plugs and connectors.

### d. Assembly

#### NOTE

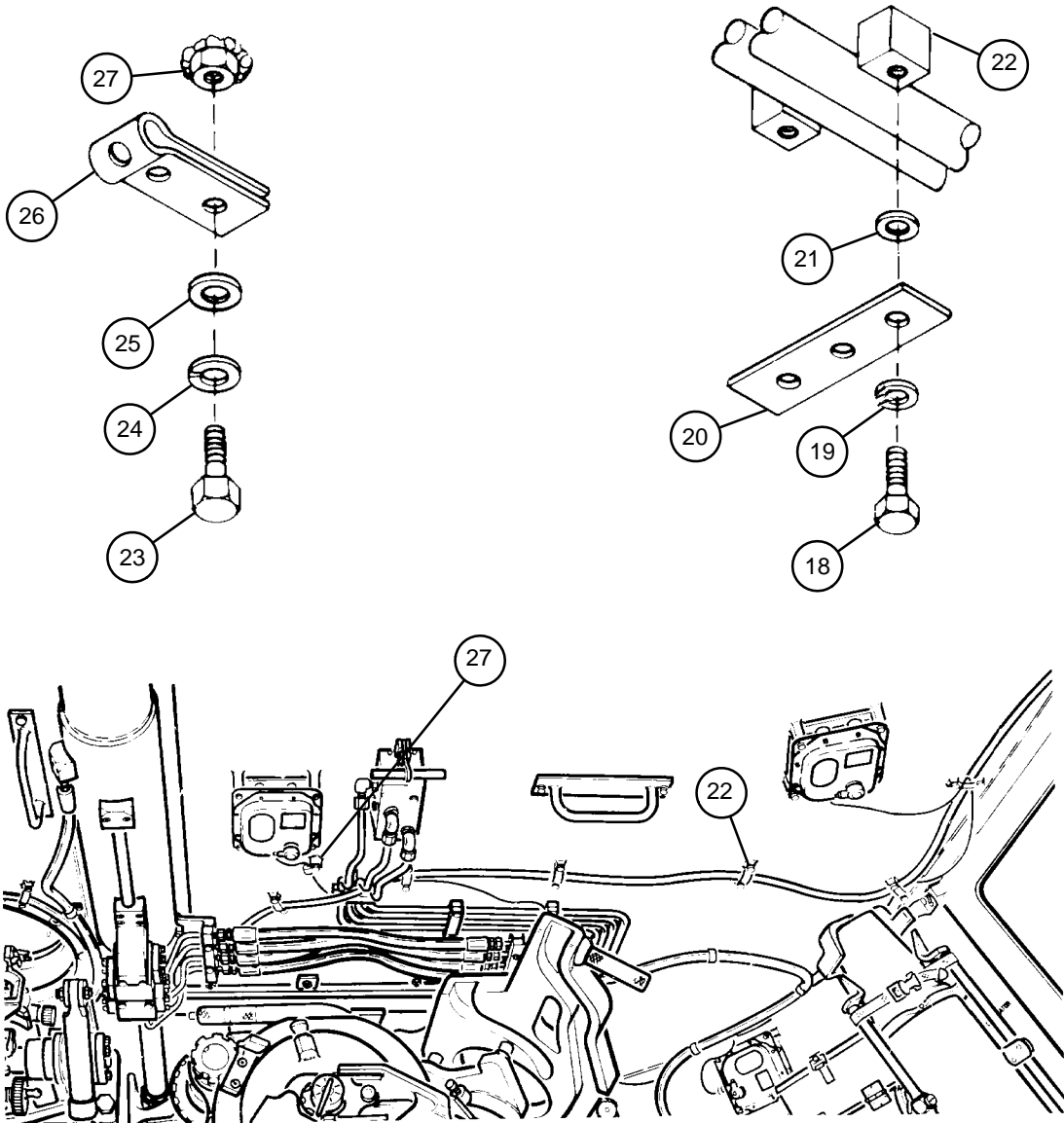
After assembly, check to ensure the wiring bundles will not be pinched by commander's seat.

- 1 Use new tape (33) to bundle power system wiring harness (intercom) (36), cab power lead assembly (35), and panoramic telescope to dome light lead assembly (34).
- 2 Install three cap screws (32), three flat washers (31), three plastic attaching straps (30), three flat washers (29), and three new self-locking nuts (28) on harness assembly.



**e. Installation**

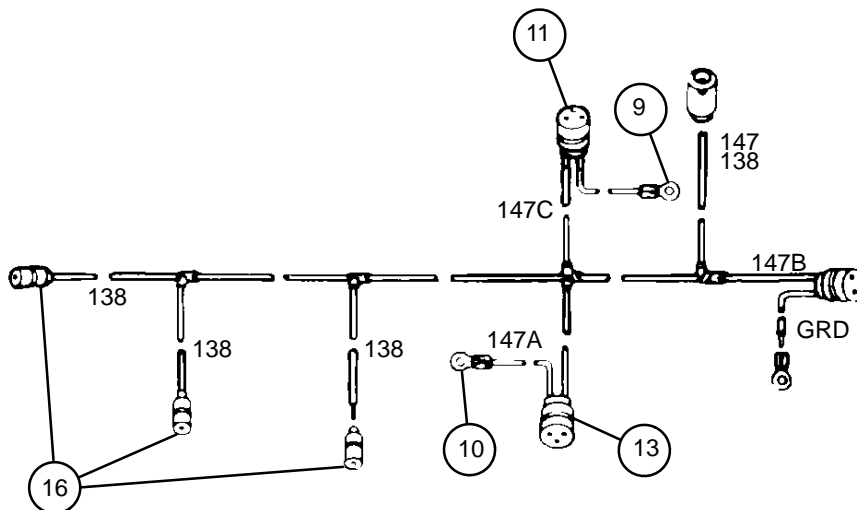
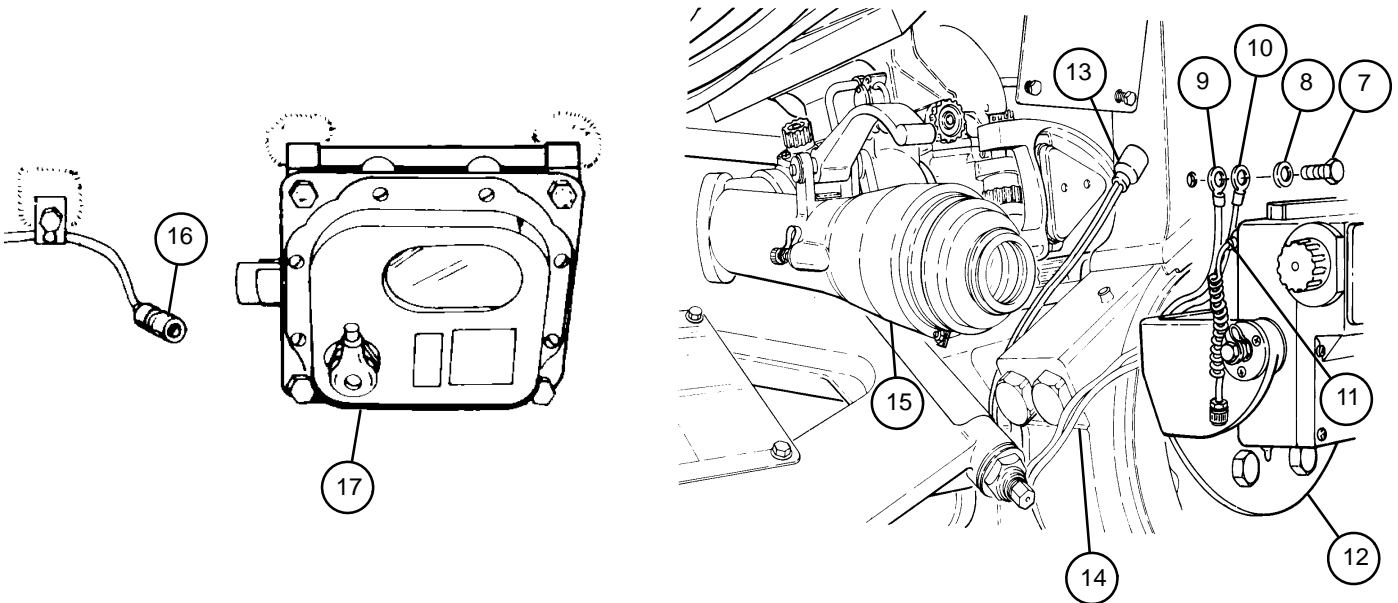
- 1 Install four plastic attaching straps (26), eight flat washers (25), eight new lockwashers (24), and eight cap screws (23) on welded hex nut attachment assemblies (27).
- 2 Install four flat washers (21), two plastic attaching straps (20), four new lockwashers (19), and four cap screws (18) on channel-type attachment assembly (22).



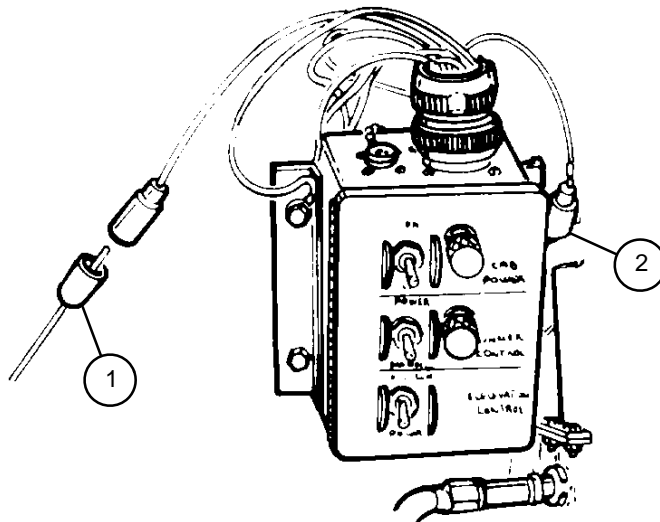
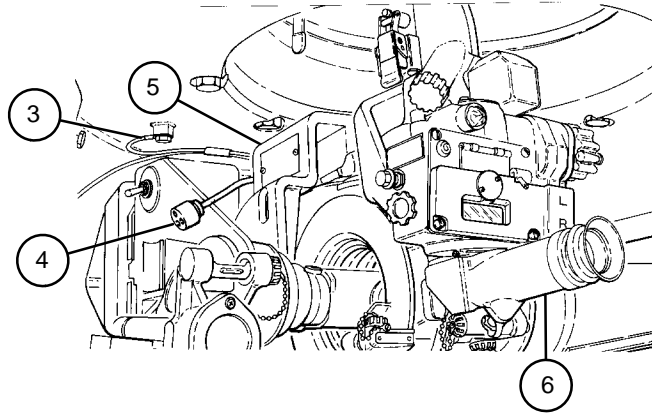
8-3 PANORAMIC TELESCOPE TO DOME LIGHT LEAD ASSEMBLY — CONTINUED

e. Installation — Continued

- 3 Connect three connectors (16), wire 138, to three dome light assemblies (17).
- 4 Connect connector (13), wire 147A, to M146 mount (14) for M118A2/M118A3 elbow telescope (15).
- 5 Connect connector (11), wire 147C, to M15 elevation quadrant (12).
- 6 Install flat washer (8) and hex cap screw (7) to connect terminals (9 and 10) at ground lead wires 147A and 147C.



- 7 Connect connector (4), wire 147B, to M145/M145A1 telescope mount (5) for the M117/M117A2 panoramic telescope (6).
- 8 Connect terminal (3) by installing hex nut and flat washer (not shown) to roof of cab.
- 9 Connect connector (1), wire 138/147, at quick-disconnect on gunner's selector switch box assembly (2).



## 8-4 CAB POWER LEAD ASSEMBLY

- This task covers:
- a. Removal
  - b. Disassembly/Assembly
  - c. Testing
  - d. Installation

### INITIAL SETUP

Test Equipment

Multimeter (item 6, Appx H)

Tools

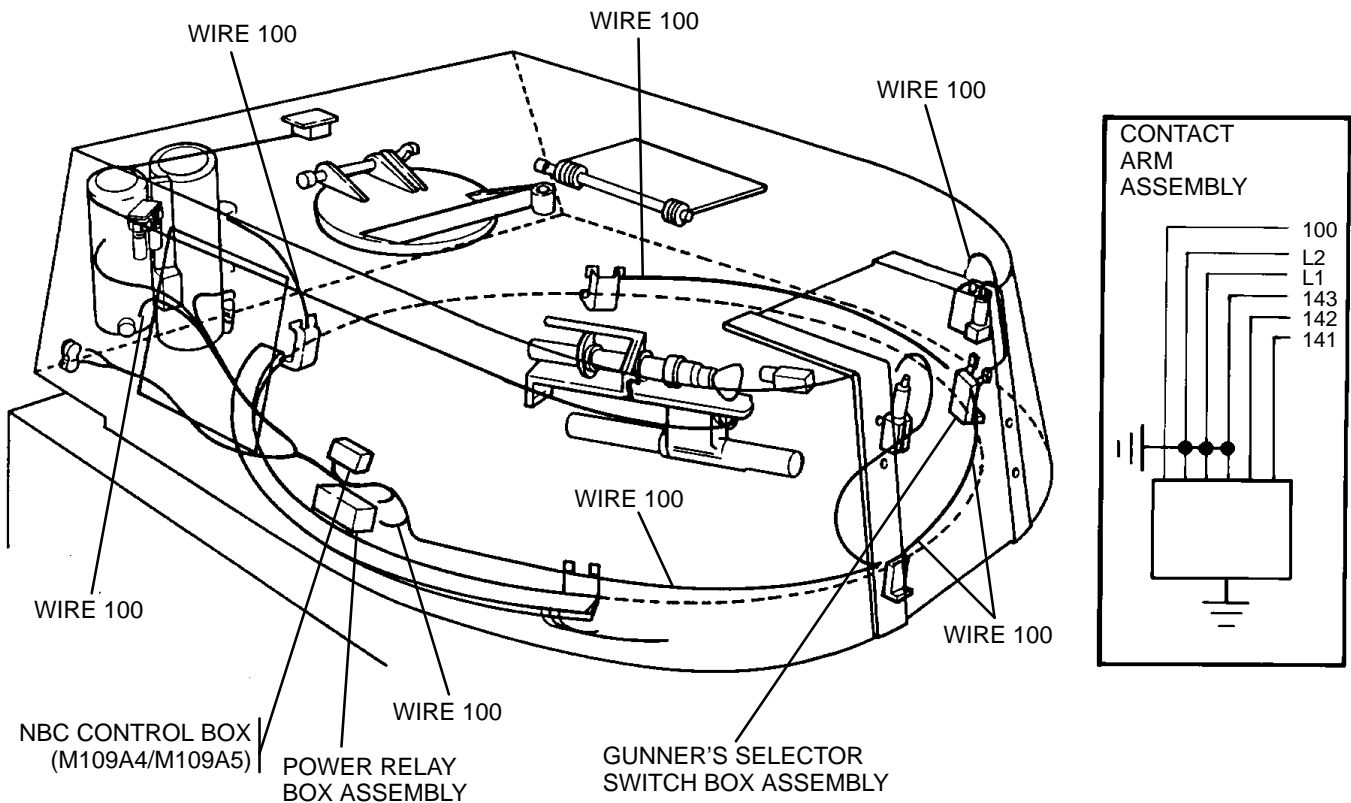
Artillery and turret mechanic's tool kit  
(SC 5180-95-CL-A12)

Materials/Parts

Lockwashers (22) (item 86, Appx G)  
Self-locking nuts (3) (item 184, Appx G)  
Tape, black (electrical) (item 39, Appx D)

Equipment Condition

Disconnect batteries (TM 9-2350-311-10)





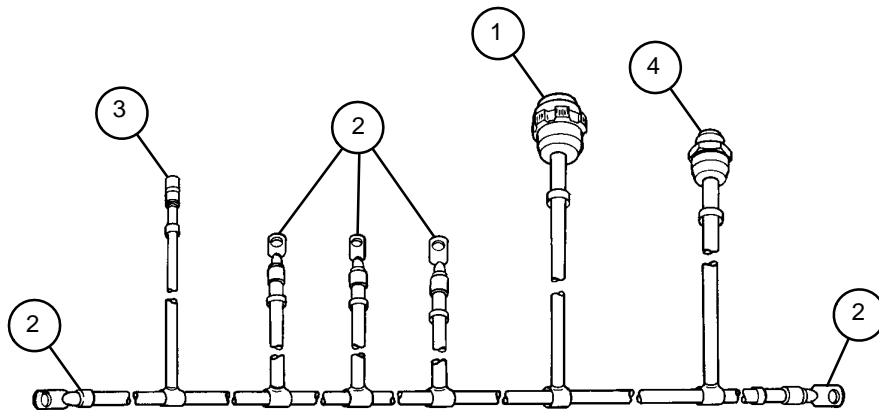
**a. Removal**

- 1 Disconnect female connector (1), wire 100, at power relay box assembly.
- 2 Disconnect lug terminals (2) at contact arm assemblies (para 9-3).
- 3 Disconnect connector (3), wire 100, at quick-disconnect on gunner's selector switch box assembly.

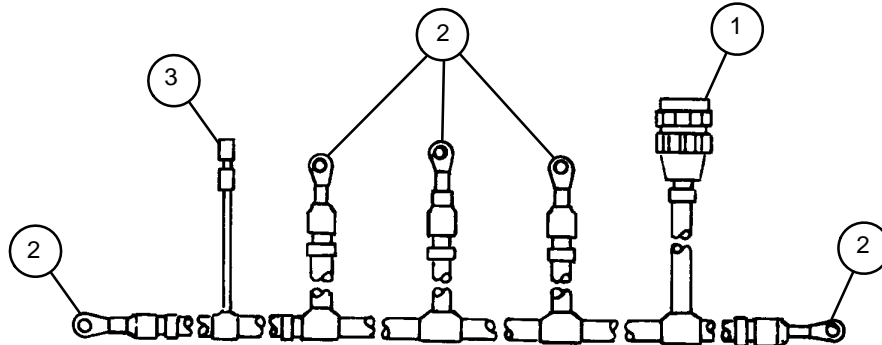
**NOTE**

Step 4 applies to M109A4/M109A5 howitzers only.

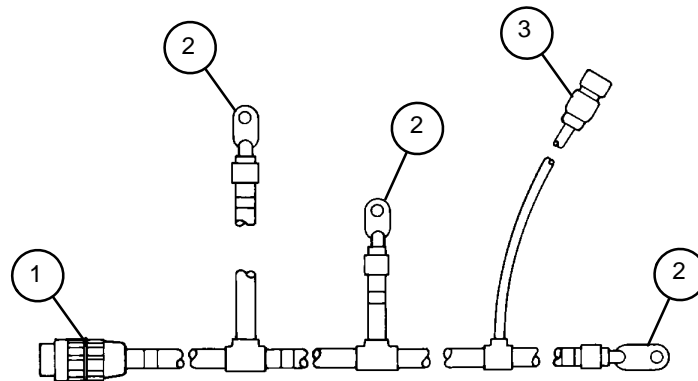
- 4 Disconnect connector (4) at NBC control box.



5 CONTACT ARM ASSEMBLY ON M109A4/M109A5 HOWITZERS



5 CONTACT ARM ASSEMBLY ON M109A2/M109A3 HOWITZERS



3 CONTACT ARM ASSEMBLY ON M109A3 HOWITZERS

## 8-4 CAB POWER LEAD ASSEMBLY — CONTINUED

### a. Removal — Continued

- 5 Remove three self-locking nuts (5), six flat washers (6), three plastic attaching straps (7), and three cap screws (8) from cab power lead assembly positioned at turret lock. Discard self-locking nuts.
- 6 Remove 22 cap screws (9), 22 lockwashers (10), 22 flat washers (11), and 22 plastic attaching straps (12) from cab power lead assembly at 22 hex nuts (13) welded to perimeter of cab ring. Discard lockwashers.

### b. Disassembly/Assembly

#### NOTE

- Cab power lead assembly, wire 100, is taped into a wiring bundle with the following:  
 Power system wiring harness (intercom)  
 Gunner's elevation control switch lead assembly  
 Panoramic telescope to dome light lead assembly (from cab traverse lock to below selector valve assembly on cab race ring).
- Tape must be removed from wiring bundle to remove any specific wiring harness. Apply tape after assembly.
- After assembly, check to ensure the wiring bundles will not be pinched by commander's seat.

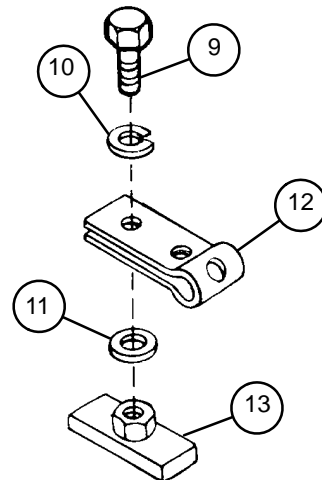
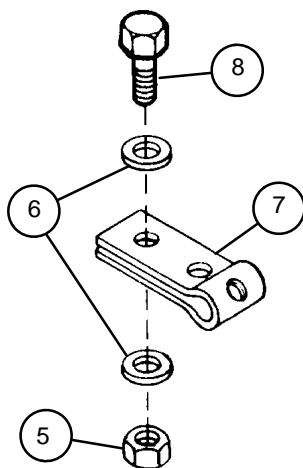
See repair procedures for harnesses, plugs, and terminals (para 8-1).

### c. Testing

Using multimeter, test cab power lead assembly for continuity through all plugs and connectors.

### d. Installation

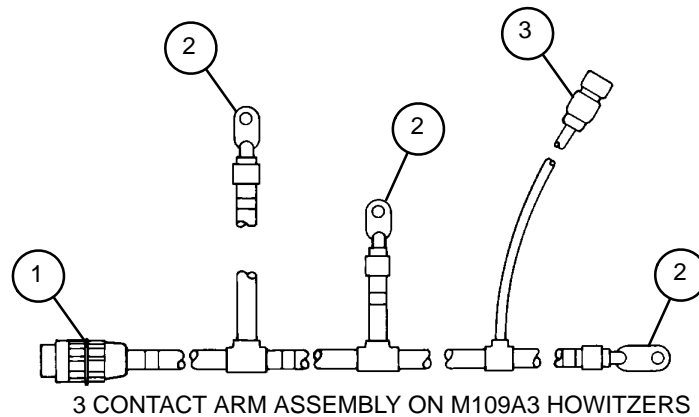
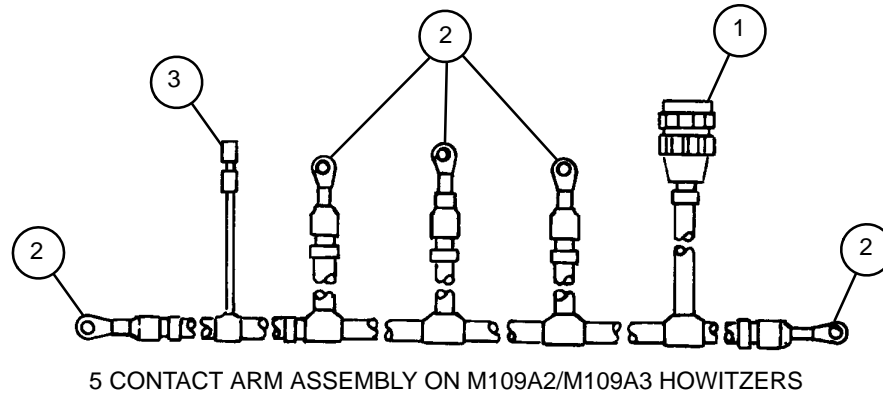
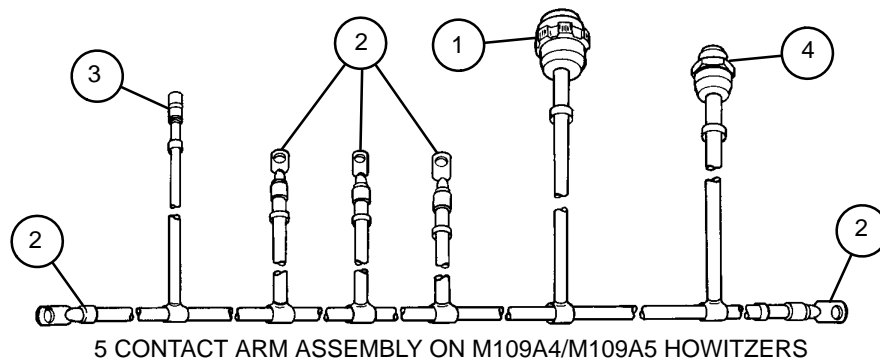
- 1 Install 22 plastic attaching straps (12), 22 flat washers (11), 22 new lockwashers (10), and 22 cap screws (9) to cab power lead assembly on 22 hex nuts (13) welded to perimeter of cab ring.
- 2 Install three cap screws (8), three plastic attaching straps (7), six flat washers (6), and three new self-locking nuts (5) to cab power lead assembly positioned at turret lock.



**NOTE**

Step 3 applies to M109A4/M109A5 howitzers only.

- 3 Connect connector (4) at NBC control box.
- 4 Connect connector (3), wire 100, at gunner's selector switch box assembly.
- 5 Connect lug terminals (2) at contact arm assemblies.
- 6 Connect female connector (1), wire 100, at power relay box assembly.



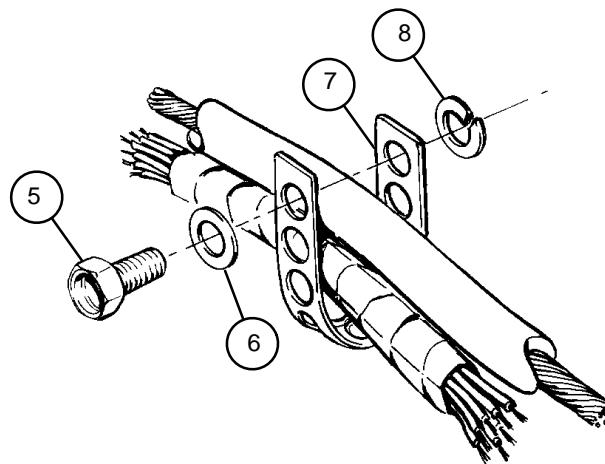
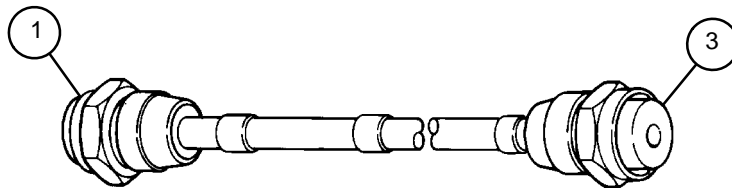
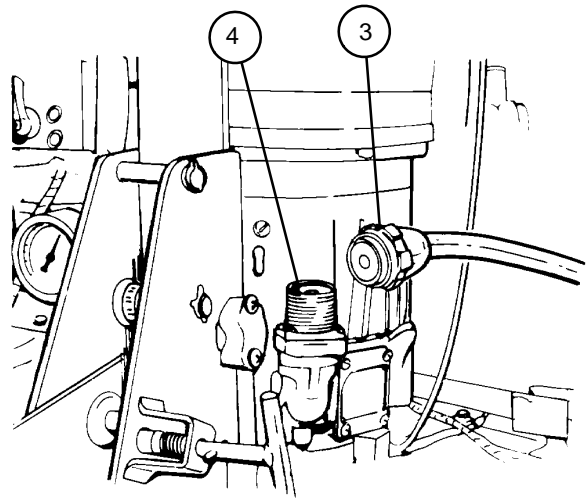
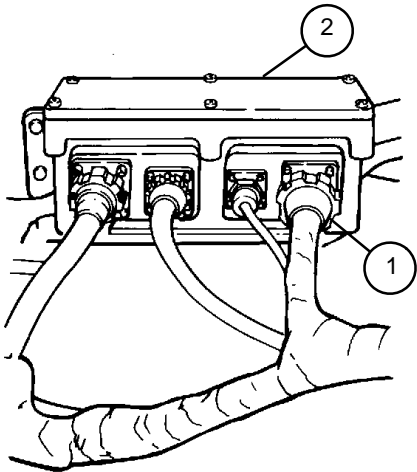


a. Removal

**NOTE**

Tape must be removed from wiring bundle to remove any specific wiring harness. Apply tape after assembly.

- 1 Disconnect connector (1), wire 104, from power relay box assembly (2).
- 2 Disconnect connector (3), wire 104, from power pack pump motor connector (4).
- 3 Remove four cap screws (5), four flat washers (6), four plastic attaching straps (7), and four lockwashers (8) from power relay box to pump motor lead assembly. Discard lockwashers.



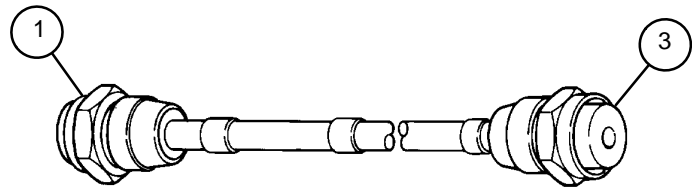
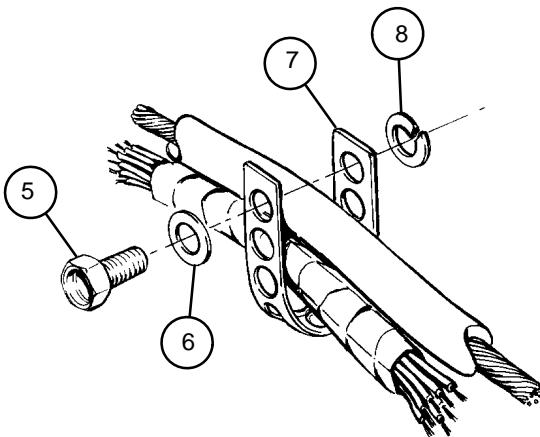
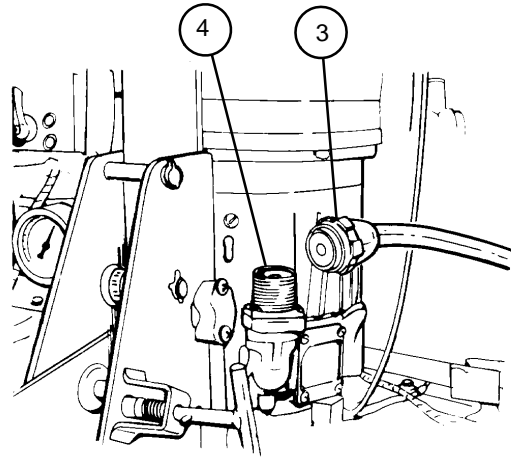
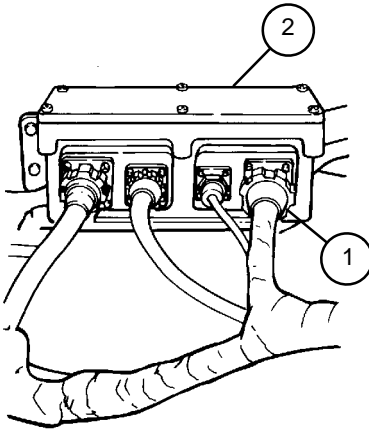
---

## 8-5 POWER RELAY BOX TO PUMP MOTOR LEAD ASSEMBLY — CONTINUED

---

### ■ b. Installation

- 1 Install four new lockwashers (8), four plastic attaching straps (7), four flat washers (6), and four cap screws (5) on power relay box to pump motor lead assembly.
- 2 Connect connector (3), wire 104, to power pack pump motor connector (4).
- 3 Connect connector (1), wire 104, to power relay box assembly (2).





---

## 8-6 POWER RELAY BOX TO PRESSURE SWITCH WIRING HARNESS — CONTINUED

---

### a. Removal

#### NOTE

The power relay box to pressure switch wiring harness is taped into a wiring bundle and is removed by removing the electrical tape. Replace tape as needed during installation.

- 1 Disconnect female connector (1), wire 645, from power relay box assembly (2).
- 2 Disconnect connector (3), wire 645, from quick-disconnect near pressure switch (4).
- 3 Disconnect female connector (5) from pressure switch (4).
- 4 Remove two cap screws (6), two flat washers (7), two plastic attaching straps (8), and two lockwashers (9) from power relay box to pressure switch wiring harness and vehicle. Discard lockwashers.

### b. Disassembly/Assembly

See repair procedures for harnesses, plugs and terminals (para 8-1).

### c. Testing

Using multimeter, test power relay box to pressure switch wiring harness for continuity through all plugs and connectors.

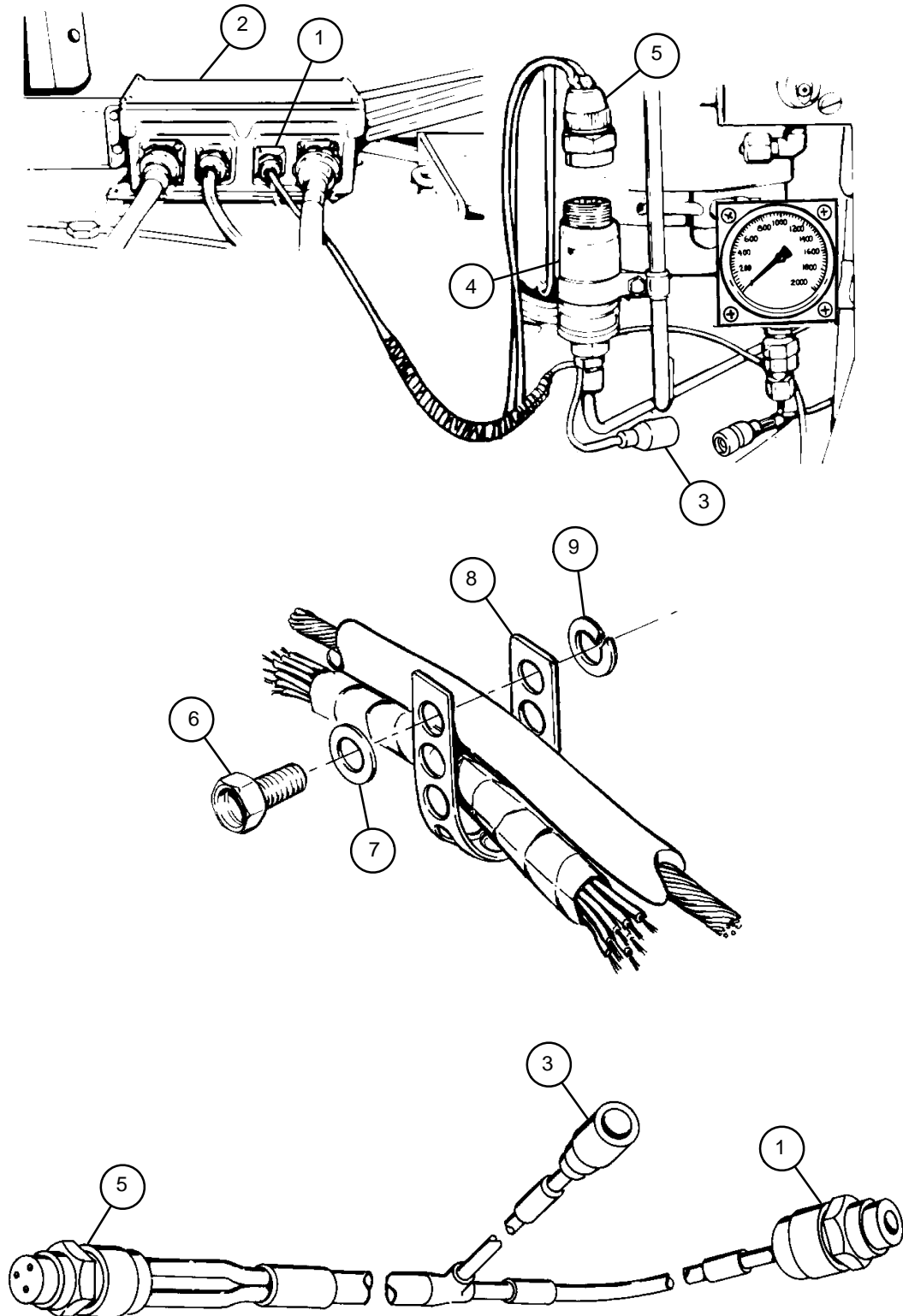
### d. Installation

- 1 Install two plastic attaching straps (8), two flat washers (7), two new lockwashers (9), and two cap screws (6) to power relay box to pressure switch wiring harness and to vehicle.
- 2 Connect female connector (5) to pressure switch (4).
- 3 Connect connector (3), wire 645, to quick-disconnect near pressure switch (4).
- 4 Connect female connector (1), wire 645, to power relay box assembly (2).

#### NOTE

After installation, check to ensure the wiring bundles will not be pinched by commander's seat.





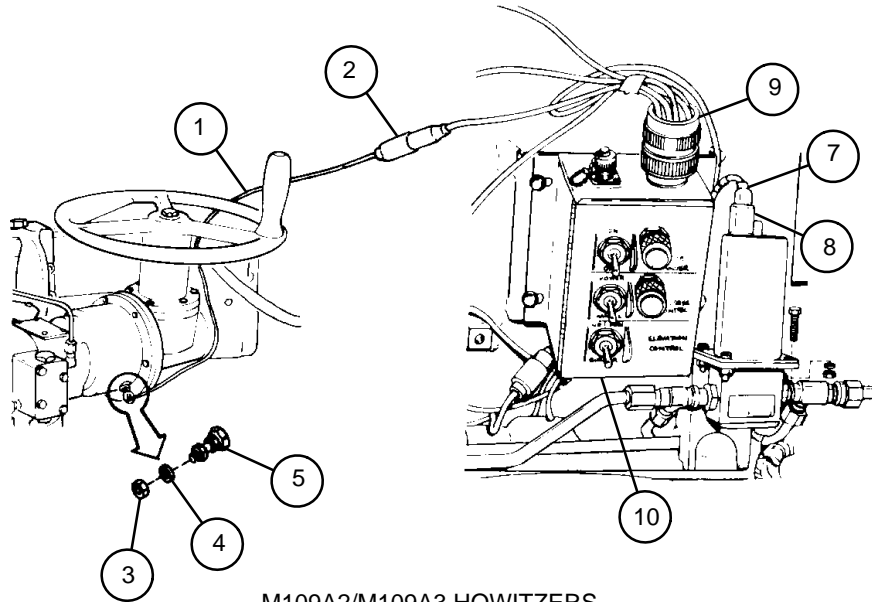


a. Removal

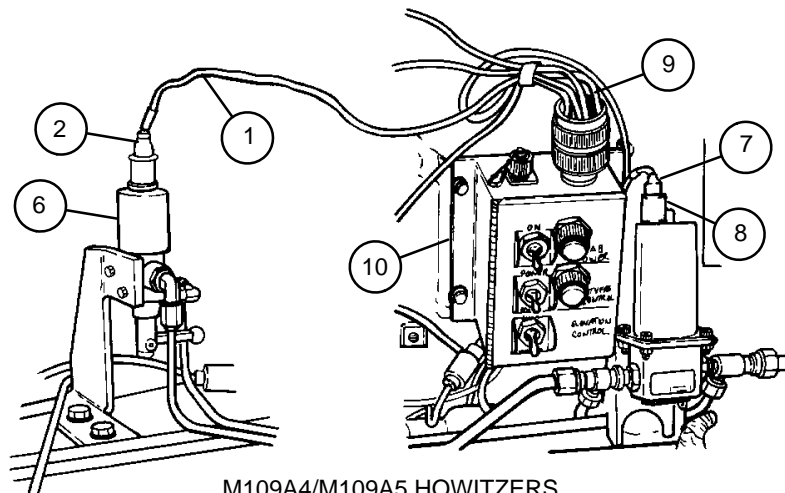
**NOTE**

Refer to steps 1 and 2 to disconnect wire 819B on M109A2/M109A3 howitzers. Refer to step 3 to disconnect wire 819B on M109A4/M109A5 howitzers.

- 1 Disconnect wire 819B (1) at gunner's selector switch box assembly quick-disconnect (2).
- 2 Remove hex nut (3), flat washer (4), and connector (1), wire 819B, at electrical contact assembly (5).
- 3 Disconnect wire 819B (1) from clutch valve (6).
- 4 Disconnect wire 825A (7) at solenoid valve connector (8).
- 5 Disconnect connector (9) from gunner's selector switch box assembly (10).



M109A2/M109A3 HOWITZERS



M109A4/M109A5 HOWITZERS

## 8-7 CAB TRAVERSING MECHANISM HARNESS — CONTINUED

### a. Removal — Continued

- 6 Remove wires 819B (1) and 825A (7) from sockets G (11) and C (12) of connector (9) (para 8-1).

### b. Disassembly/Assembly

See repair procedures for harnesses, plugs and terminals (para 8-1).

### c. Testing

Using multimeter, test cab traversing mechanism harness for continuity through all plugs and connectors.

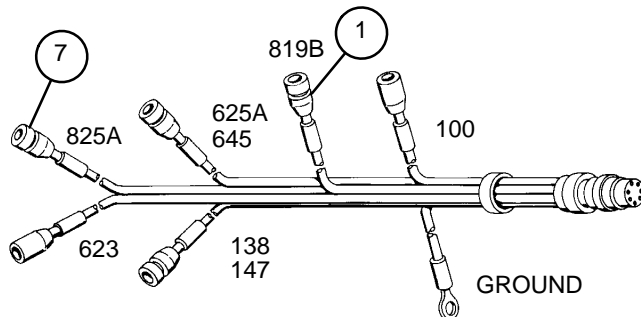
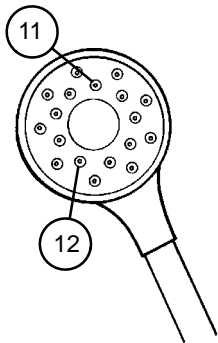
### d. Installation

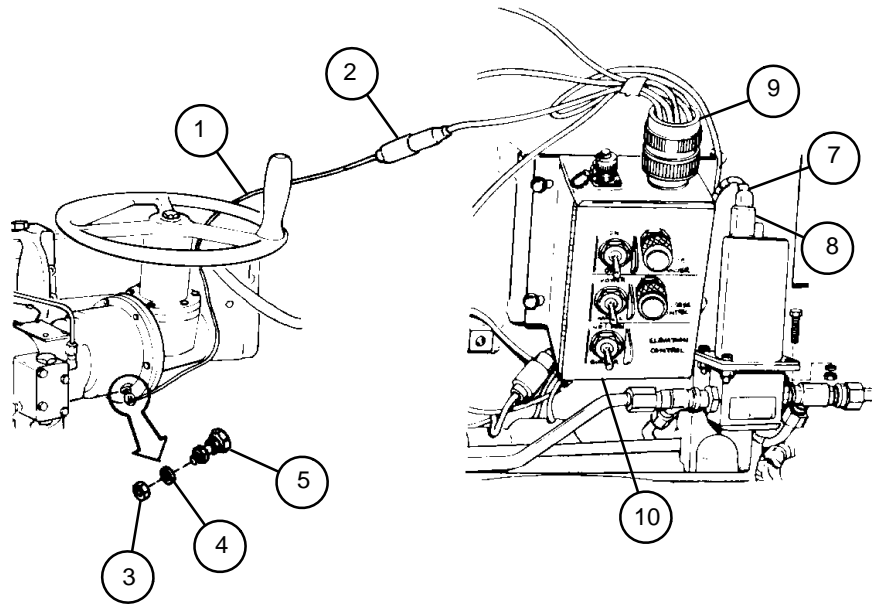
- 1 Install wires 819B (1) and 825A (7) in sockets G (11) and C (12) at connector (9). See information on how to assemble connector (para 8-1).
- 2 Connect connector (9) to gunner's selector switch box assembly (10).
- 3 Connect wire 825A (7) to solenoid valve connector (8).

#### NOTE

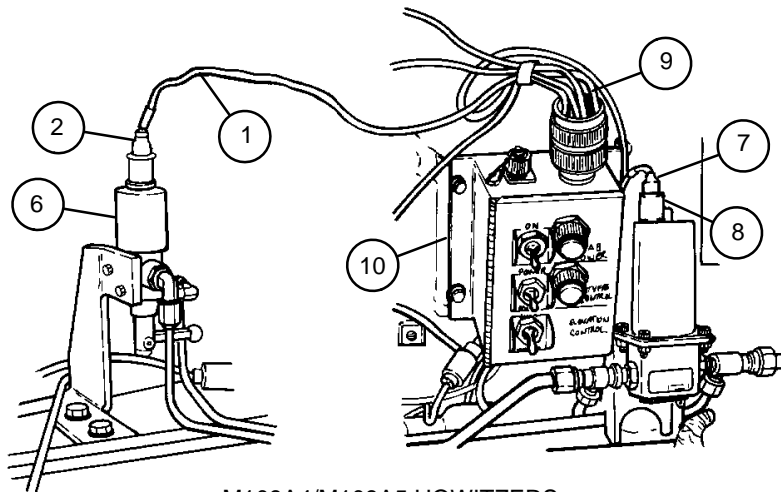
Refer to steps 4 and 5 to connect wire 819B on M109A2/M109A3 howitzers. Refer to step 6 to connect wire 819B on M109A4/M109A5 howitzers.

- 4 Install hex nut (3), flat washer (4), and wire 819B (1) on electrical contact assembly (5).
- 5 Connect wire 819B (1) to quick-disconnect (2).
- 6 Install wire 819B (1) on top of clutch valve (6).





M109A2/M109A3 HOWITZERS



M109A4/M109A5 HOWITZERS

## 8-8 GUNNER'S ELEVATION CONTROL SWITCH LEAD ASSEMBLY

This task covers: a. Removal b. Installation

### INITIAL SETUP

#### Test Equipment

Multimeter (item 6, Appx H)

#### Tools

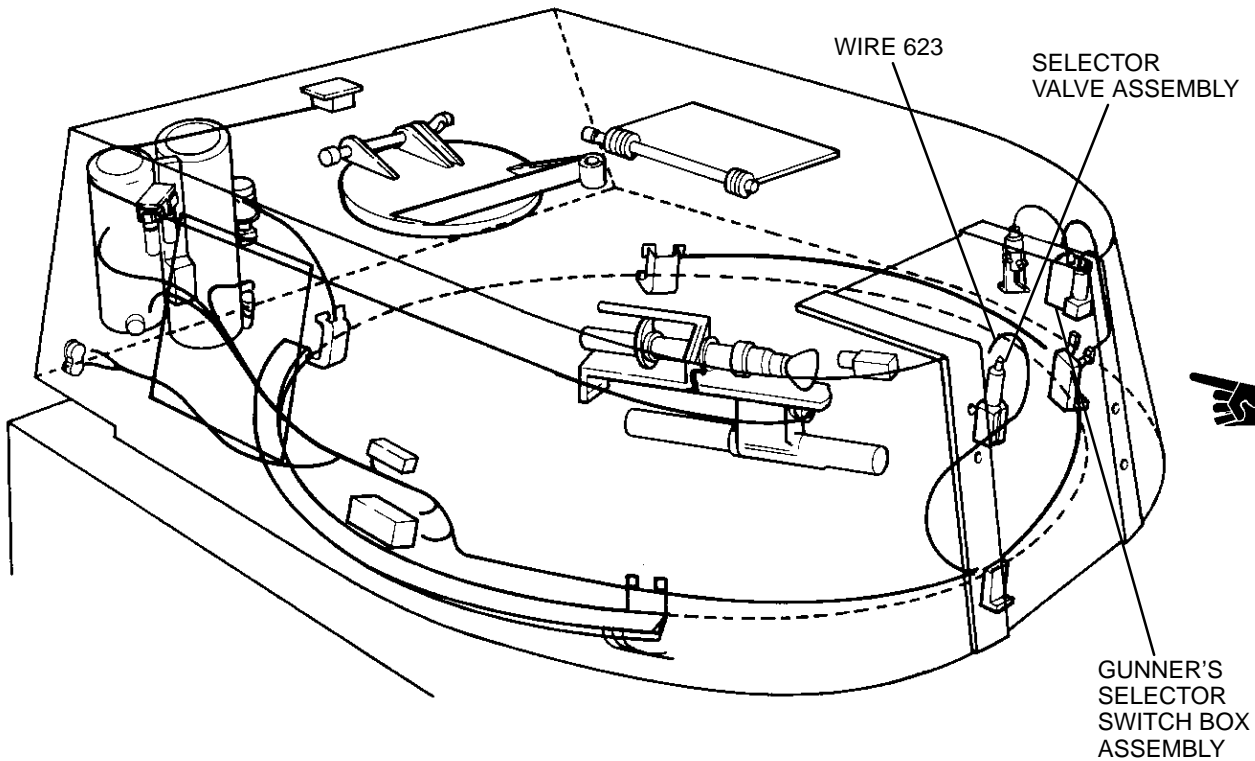
Artillery and turret mechanic's tool kit  
(SC 5180-95-CL-A12)

#### Materials/Parts

Lockwashers (3) (item 86, Appx G)  
Self-locking nuts (3) (item 184, Appx G)  
Tape, black (electrical) (item 39, Appx D)

#### Equipment Condition

Disconnect batteries (TM 9-2350-311-20-1)

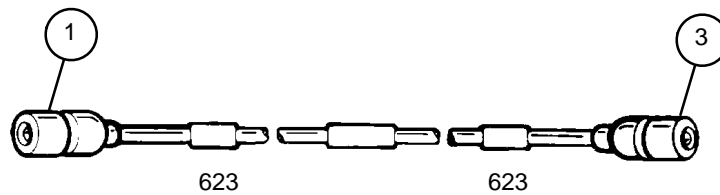
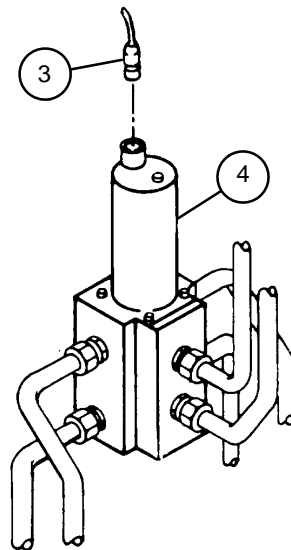
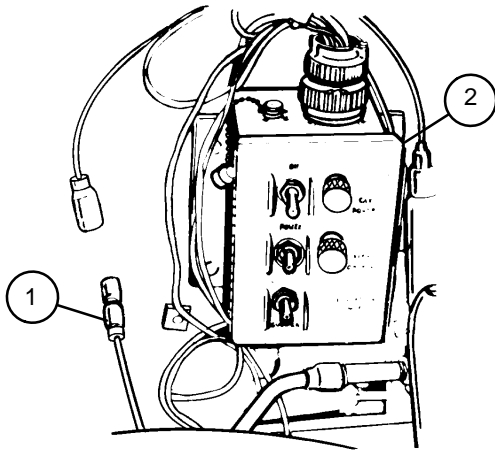


a. Removal

**NOTE**

- The gunner's elevation control switch lead assembly, wire 623, is taped into a wiring bundle with the following harnesses:  
Cab power lead assembly  
Power relay box to intercom power supply lead assembly
- Tape must be removed from wiring bundle to remove any specific wiring harness. Apply tape after assembly.

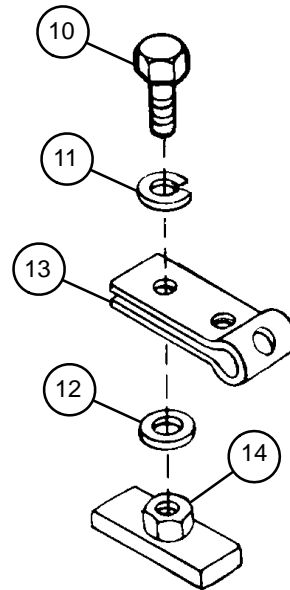
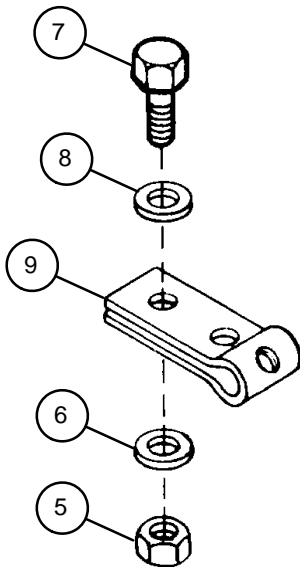
- 1 Disconnect connector (1), wire 623, from quick-disconnect at gunner's selector switch box assembly (2).
- 2 Disconnect connector (3), wire 623, at selector valve assembly solenoid (4).



## 8-8 GUNNER'S ELEVATION CONTROL SWITCH LEAD ASSEMBLY — CONTINUED

### a. Removal — Continued

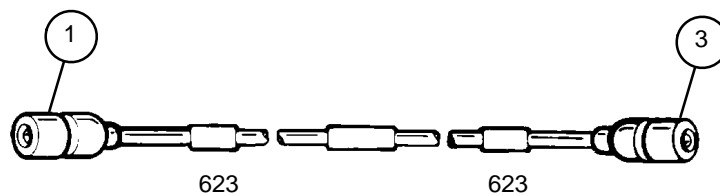
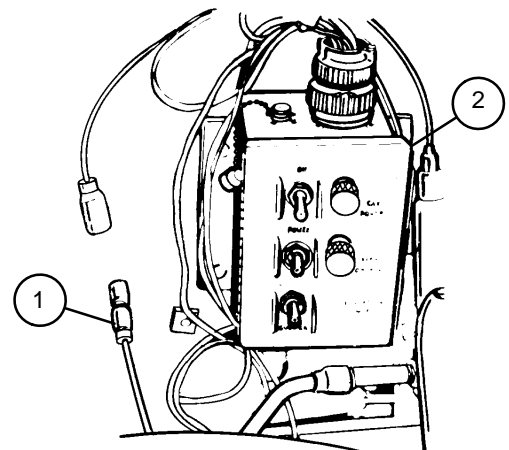
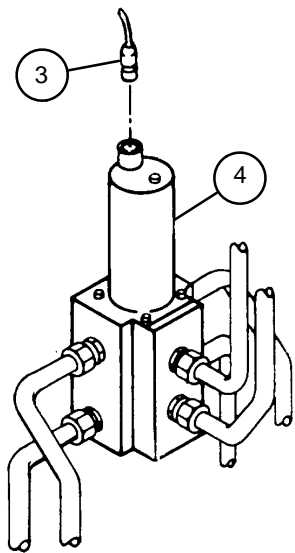
- 3 Remove three self-locking nuts (5), three flat washers (6), three cap screws (7), three flat washers (8), and three plastic attaching straps (9). Discard self-locking nuts.
- 4 Remove three cap screws (10), three lockwashers (11), three flat washers (12), and three plastic attaching straps (13) from three hex nuts (14) welded to cab. Discard lockwashers.
- 5 Remove wire 623 from wiring bundle.





**b. Installation**

- 1 Install wire 623 in wiring bundle.
- 2 Install three plastic attaching straps (13), three new lockwashers (11), three cap screws (10), and three flat washers (12) on three hex nuts (14) welded to cab.
- 3 Install three plastic attaching straps (9), three flat washers (8), three cap screws (7), three flat washers (6), and three new self-locking nuts (5).
- 4 Connect connector (3), wire 623, at selector valve assembly solenoid (4).
- 5 Connect connector (1), wire 623, to quick-disconnect at gunner's selector switch box assembly (2).



## 8-9 NBC POWER LEAD ASSEMBLY

This task covers: a. Removal b. Disassembly/Assembly  
c. Testing d. Installation

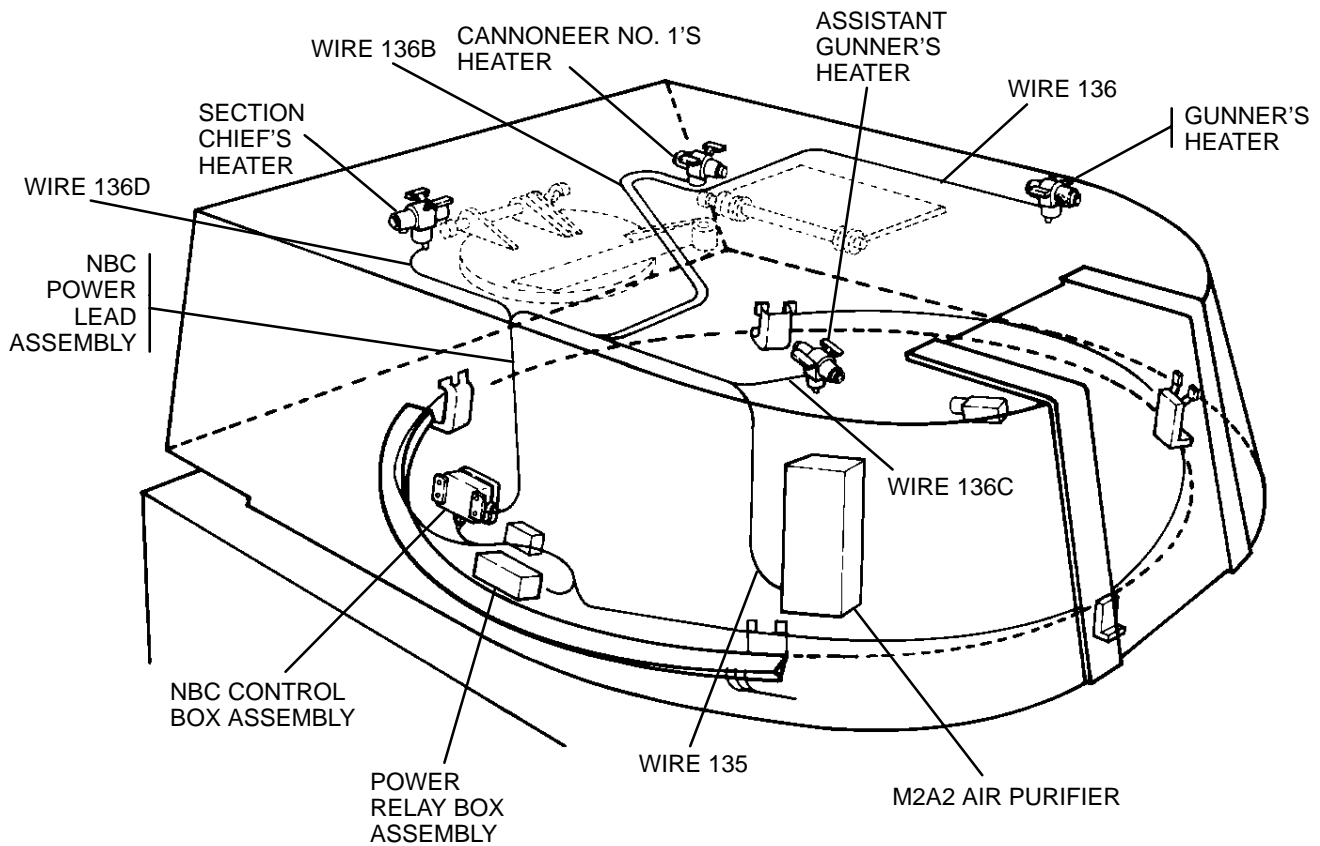
### INITIAL SETUP

Applicable Configuration  
M109A4/M109A5 howitzers

Tools  
Artillery and turret mechanic's tool kit  
(SC 5180-95-CL-A12)

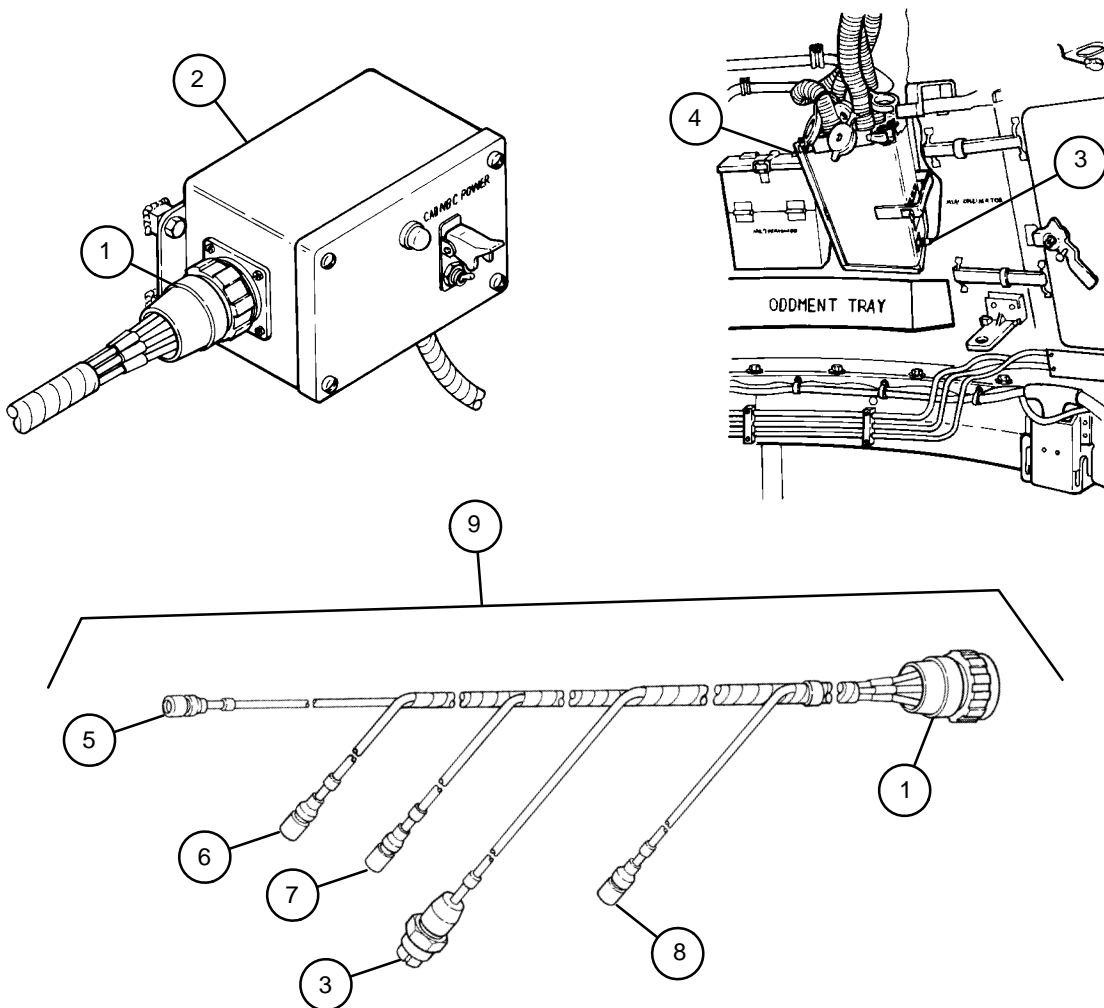
Test Equipment  
Multimeter (item 6, Appx H)

Equipment Condition  
Disconnect batteries (TM 9-2350-311-20-1)



**a. Removal**

- 1 Disconnect connector (1) from NBC control box assembly (2).
- 2 Disconnect connector (3), wire 135, from M2A2 air purifier (4).
- 3 Disconnect connector (5), wire 136A, from gunner's M3 electrical air heater.
- 4 Disconnect connector (6), wire 136B, from cannoneer no. 1's M3 electrical air heater.
- 5 Disconnect connector (7), wire 136C, from assistant gunner's M3 electrical air heater.
- 6 Disconnect connector (8), wire 136D, from section chief's M3 electrical air heater.
- 7 Carefully remove NBC power lead assembly (9) from hose mounting hardware.



## 8-9 NBC POWER LEAD ASSEMBLY — CONTINUED

---

### b. Disassembly/Assembly

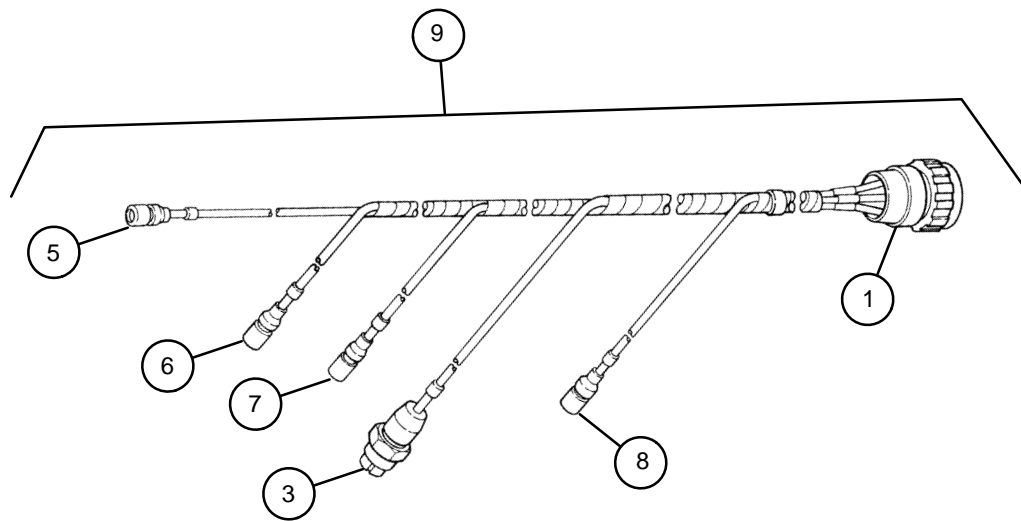
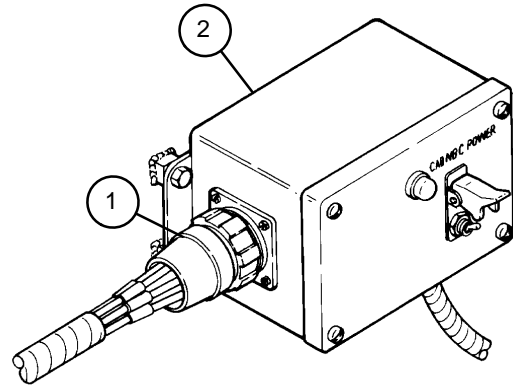
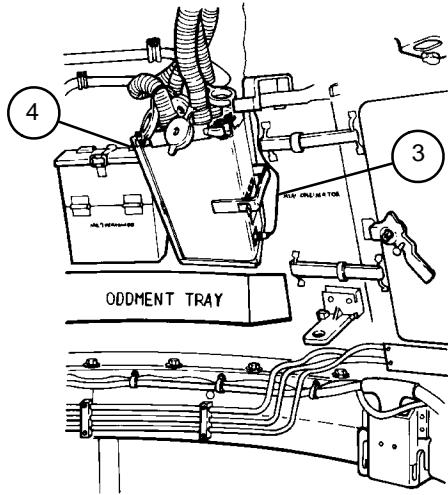
See repair procedures for harness, plugs, and terminals (para 8-1).

### c. Testing

Using multimeter, test NBC power lead assembly (9) for continuity through all terminals and connectors.

### d. Installation

- 1 Carefully route wires of NBC power lead assembly (9) through mounting hardware of their respective hoses.
- 2 Connect connector (3), wire 135, to M2A2 air purifier (4) and connector (1) to NBC control box assembly (2).
- 3 Connect connector (8), wire 136D, to section chief's M3 electrical air heater.
- 4 Connect connector (7), wire 136C, to assistant gunner's M3 electrical air heater.
- 5 Connect connector (6), wire 136B, to cannoneer no. 1's M3 electrical air heater.
- 6 Connect connector (5), wire 136A, to gunner's M3 electrical air heater.



## 8-10 NBC GROUND LEAD

- This task covers:
- |            |                         |
|------------|-------------------------|
| a. Removal | b. Disassembly/Assembly |
| c. Testing | d. Installation         |

### INITIAL SETUP

Applicable Configuration

M109A4/M109A5 howitzers

Test Equipment

Multimeter (item 6, Appx H)

Tools

Artillery and turret mechanic's tool kit  
(SC 5180-95-CL-A12)

Materials/Parts

Lockwasher (item 55, Appx G)

Lockwasher (item 77, Appx G)

Equipment Condition

Disconnect batteries (TM 9-2350-311-20-1)

#### a. Removal

- 1 Remove cap screw (1), lockwasher (2), and one end of lead (3) from M27 periscope box (4). Discard lockwasher.
- 2 Remove cap screw (5), lockwasher (6), and other end of lead (3) from top of M2A2 air purifier (7). Discard lockwasher.

#### b. Disassembly/Assembly

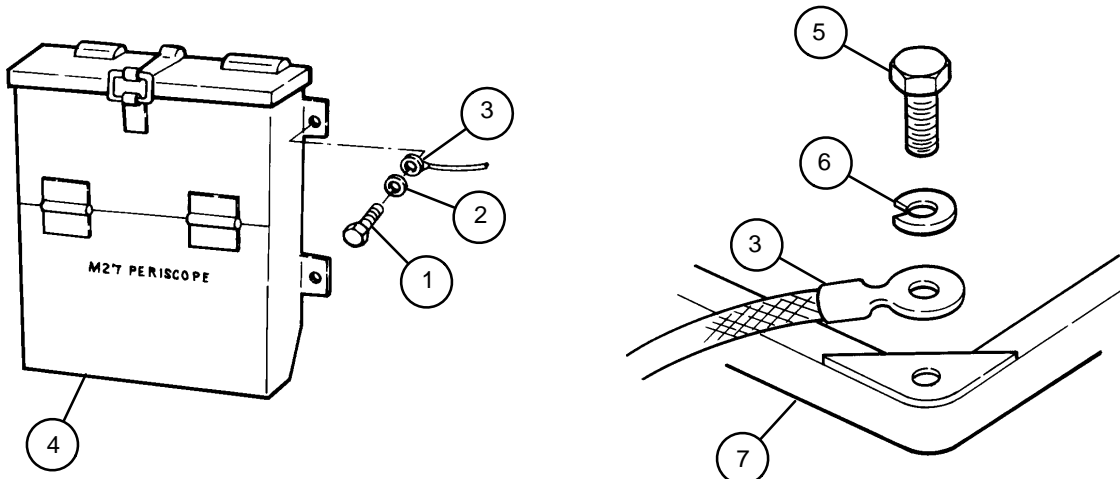
See repair procedures for terminals (para 8-1).

#### c. Testing

Using multimeter, test NBC ground lead for continuity.

#### d. Installation

- 1 Secure lead (3) to M27 periscope box (4) using new lockwasher (2) and cap screw (1).
- 2 Secure lead (3) to M2A2 air purifier (7) using new lockwasher (6) and cap screw (5).

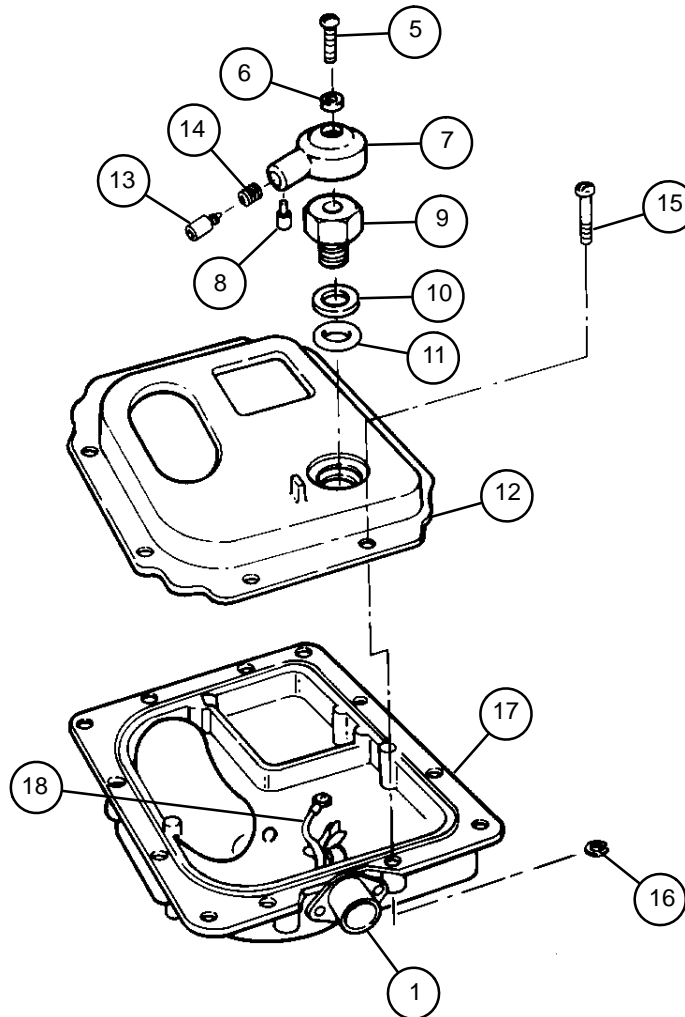




## 8-11 DOME LIGHT ASSEMBLIES — CONTINUED

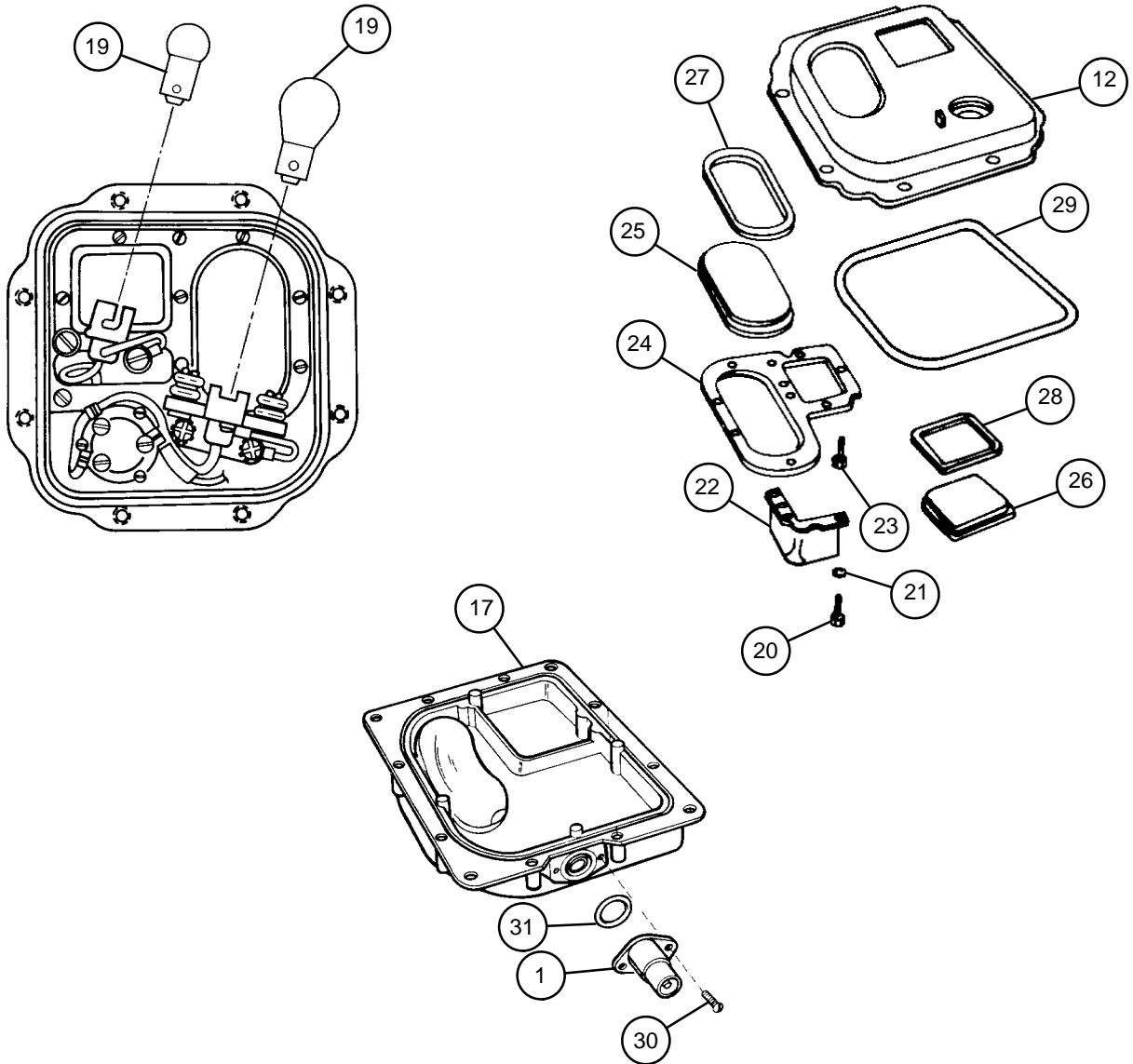
### b. Disassembly

- 1 Remove machine screw (5), lockwasher (6), knob (7), knob setscrew (8), mounting nut assembly (9), flat washer (10), and gasket (11) from lens retainer (12). Discard gasket and lockwasher.
- 2 Push in and rotate push button (13) to remove with spring (14).
- 3 Remove eight machine screws (15) and eight retaining clips (16). Separate lens retainer (12) from body (17).
- 4 Disconnect electrical lead (18) at connector (1).



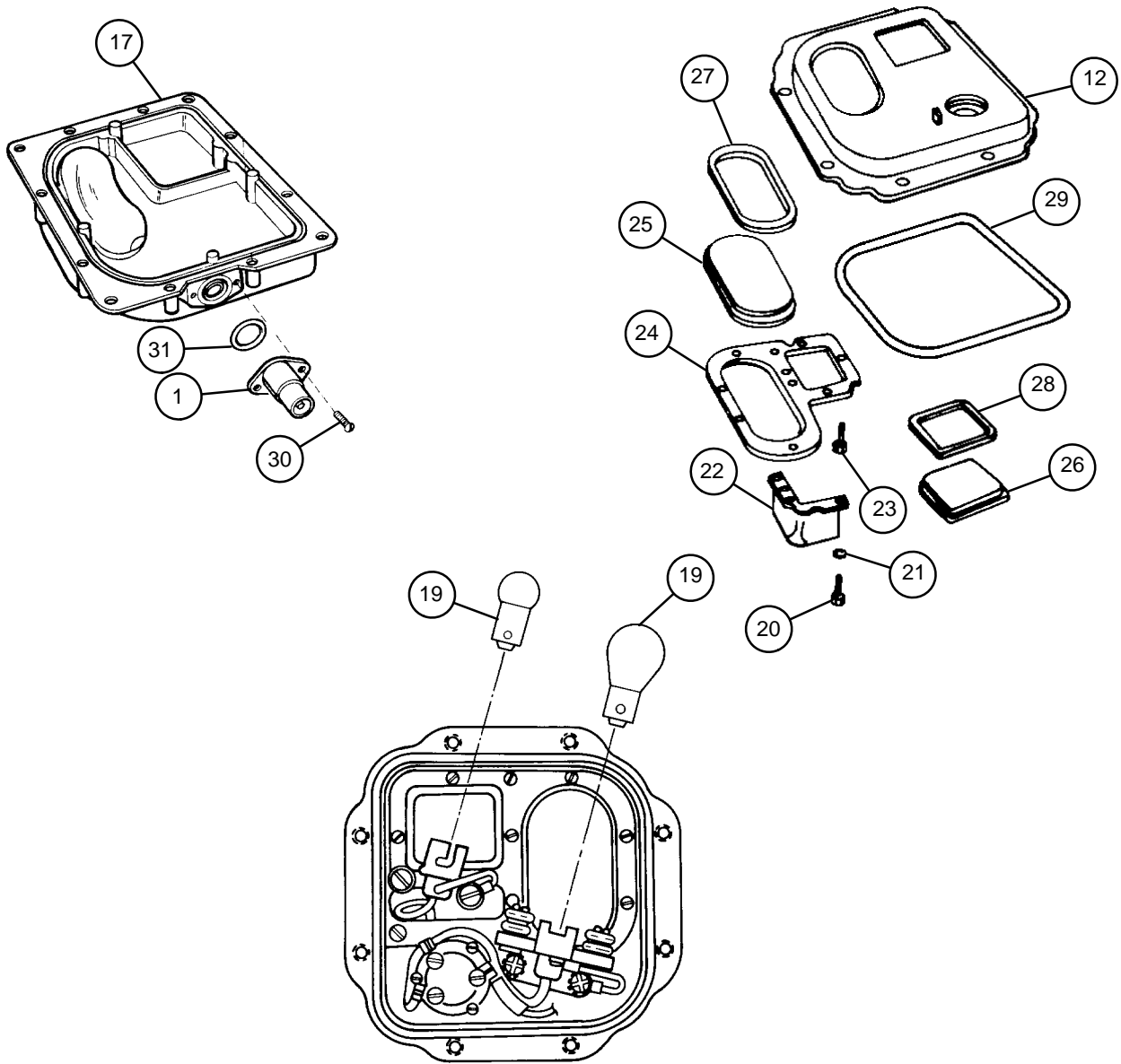


- 5 Remove two incandescent lamps (19).
- 6 Remove four machine screws (20), four lockwashers (21), and partition body (22) from body (17). Discard lockwashers.
- 7 Remove seven machine screws (23), window retaining plate (24), light lens (25), light lens (26), seal (27), gasket (28), and seal (29) from lens retainer (12). Discard gasket and seals.
- 8 Remove two machine screws (30), connector (1), and preformed packing (31) from body (17). Discard preformed packing.



c. Assembly

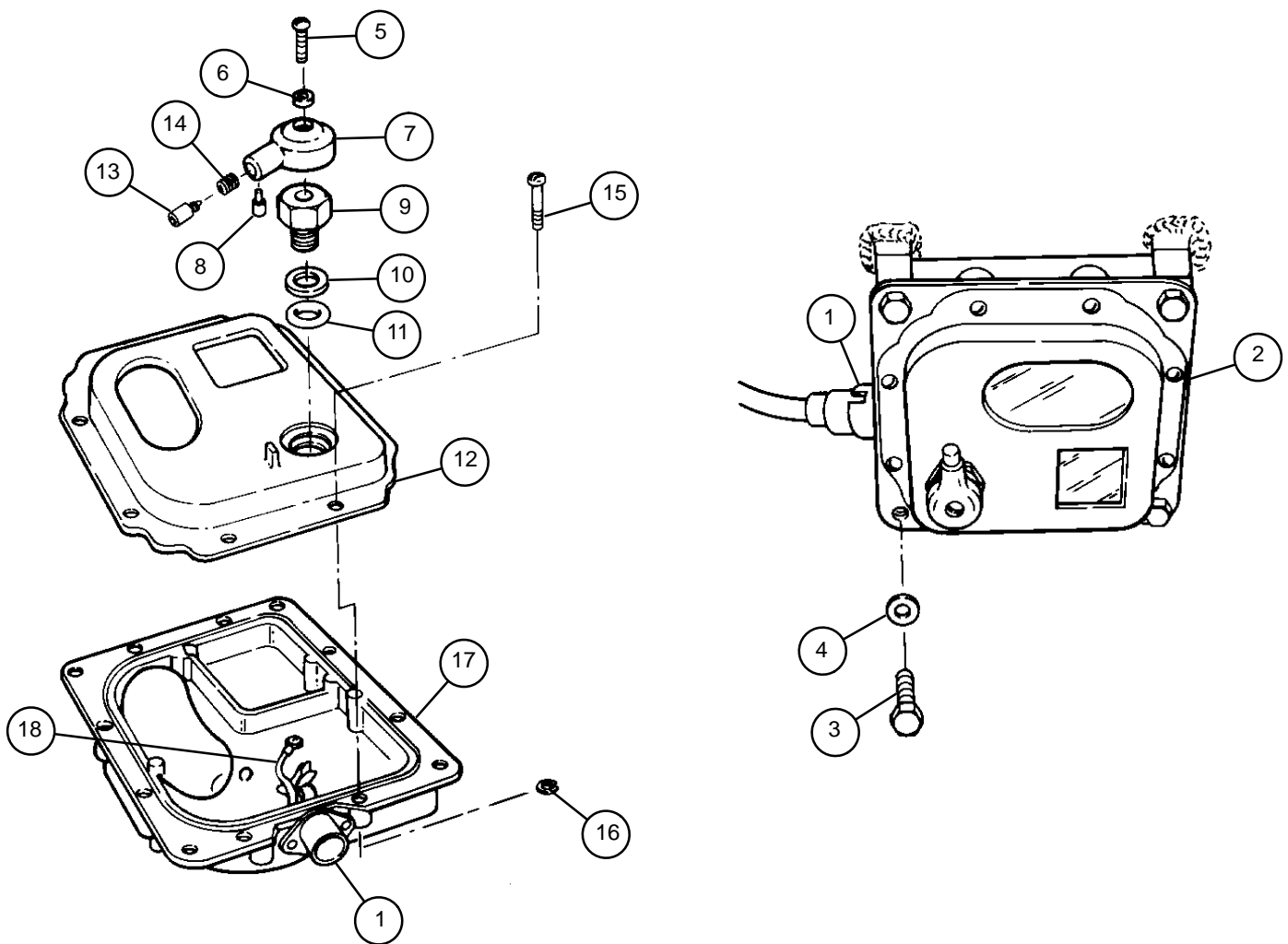
- 1 Install new preformed packing (31) and connector (1) on body (17). Install two machine screws (30) on connector (1).
- 2 Install new gasket (28), new seals (27 and 29), light lens (26), light lens (25), window retaining plate (24), and seven machine screws (23) on lens retainer (12).
- 3 Install partition body (22), four new lockwashers (21), and four machine screws (20) on body (17).
- 4 Install two incandescent lamps (19).



- 5 Connect one electrical lead (18) at connector assembly (1).
- 6 Aline lens retainer (12) with body (17). Install eight machine screws (15) and eight retaining clips (16).
- 7 Install spring (14); secure push button (13) by pushing in and rotating until it stops.
- 8 Install new gasket (11), flat washer (10), mounting nut assembly (9), knob setscrew (8), knob (7), new lock-washer (6), and machine screw (5) on lens retainer (12).

**d. Installation**

- 9 Install dome light assembly (2) using four flat washers (4) and four cap screws (3).
- 10 Connect wire 138 to connector (1) on dome light assembly (2).



---

## 8-12 GUNNER'S SELECTOR SWITCH BOX ASSEMBLY

---

- This task covers:
- a. Removal
  - b. Disassembly
  - c. Assembly
  - d. Testing
  - e. Installation
- 

### **INITIAL SETUP**

#### Test Equipment

Multimeter (item 6, Appx H)

#### Tools

Artillery and turret mechanic's tool kit  
(SC 5180-95-CL-A12)

Soldering kit (item 13, Appx H)

#### Materials/Parts

Gasket (item 93, Appx G)

Gasket (item 94, Appx G)

Gasket (item 139, Appx G)

Lockwashers (4) (item 51, Appx G)

Lockwashers (6) (item 52, Appx G)

Lockwashers (5) (item 54, Appx G)

Lockwire (V) (item 32, Appx G)

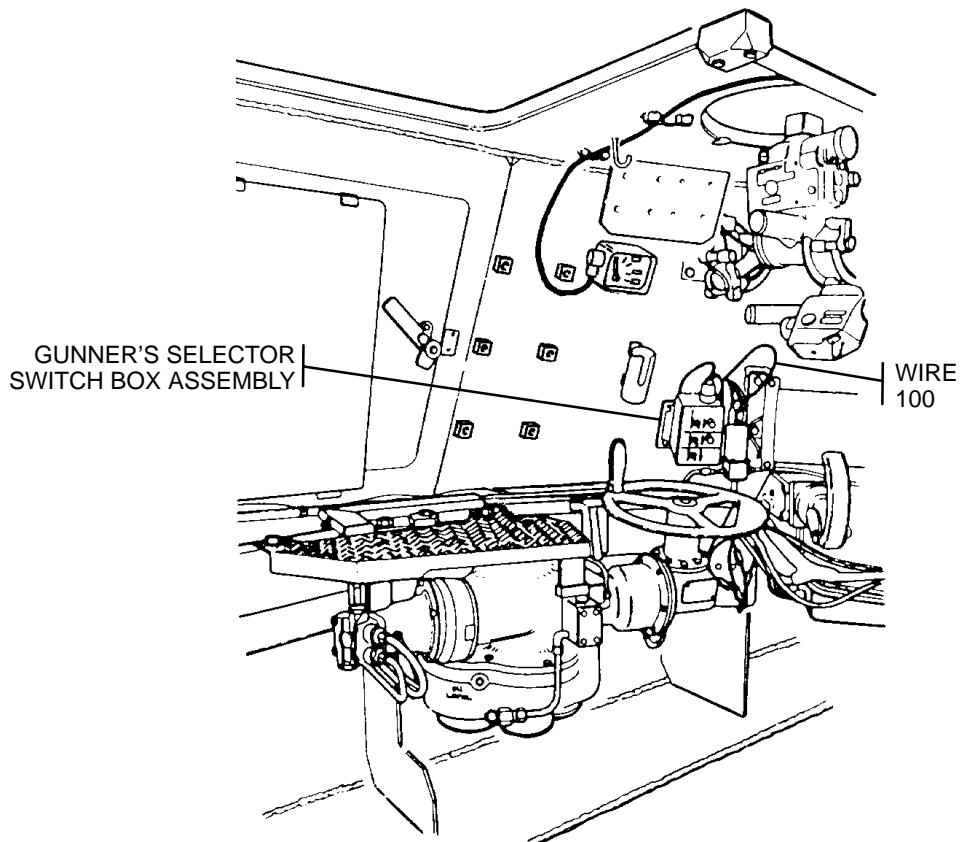
Packings (3) (item 42, Appx G)

Seals (2) (item 137, Appx G)

#### Equipment Condition

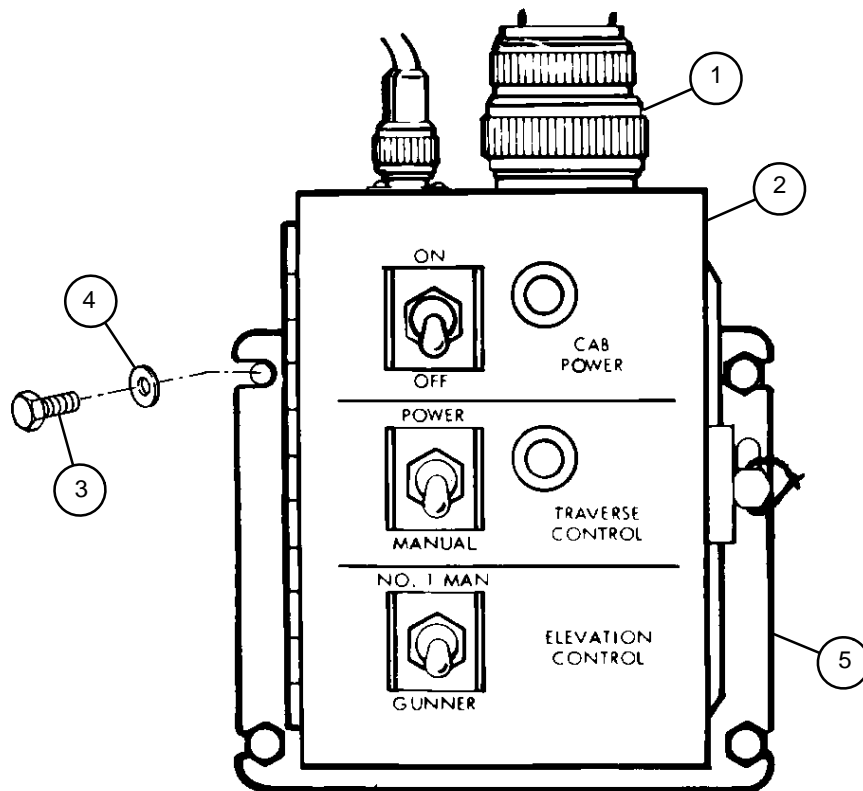
Disconnect batteries (TM 9-2350-311-10)

---



**a. Removal**

- 1 Disconnect J2 connector wiring harness (1) from gunner's selector switch box assembly (2).
- 2 Remove four cap screws (3) and four flat washers (4) from the box mount (5) in the following manner:
  - (a) Start by removing two cap screws (3) and two flat washers (4) on the left side of gunner's selector switch box assembly (2).
  - (b) Loosen two cap screws (3) on right side of gunner's selector switch box assembly (2).
  - (c) Pull gunner's selector switch box assembly (2) out toward the left and remove two cap screws (3) and two flat washers (4) on the right side of gunner's selector switch box assembly. Separate gunner's selector switch box assembly from box mount (5).



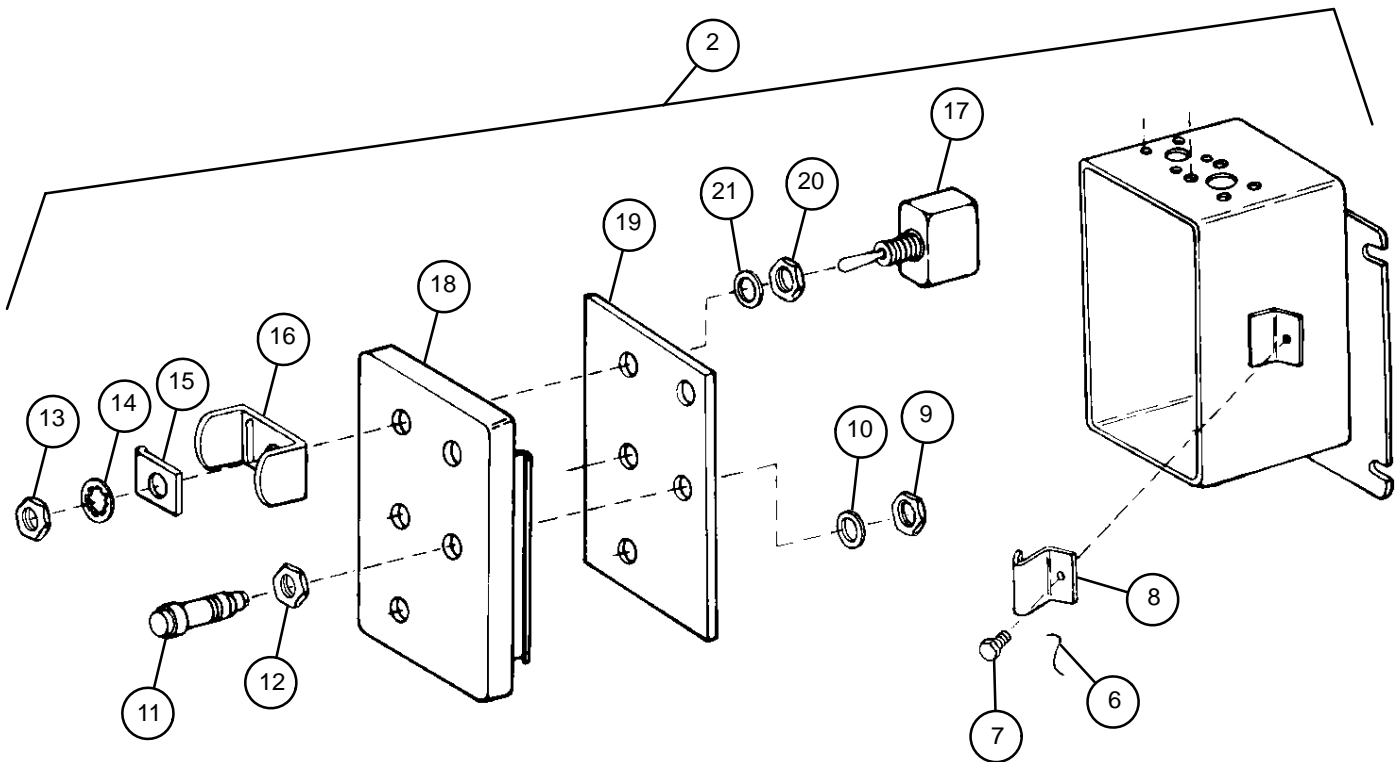
## 8-12 GUNNER'S SELECTOR SWITCH BOX ASSEMBLY — CONTINUED

### b. Disassembly

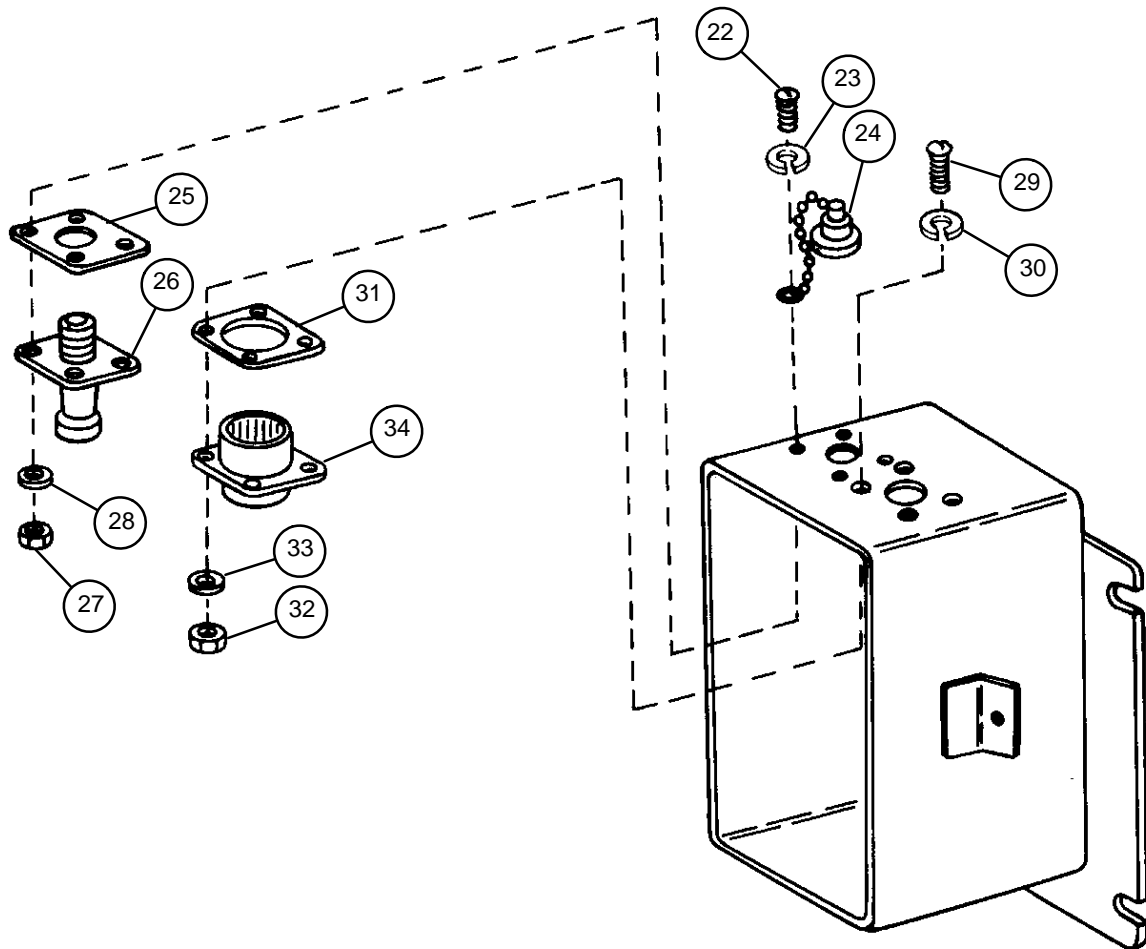
#### NOTE

All wiring, desoldered or disconnected, must be tagged or marked to assure correct assembly.

- 3 Disconnect gunner's selector switch box assembly (2) internal wiring before disassembling gunner's selector switch box assembly.
- 4 Remove lockwire (6), cap screw (7), and clamp (8) from gunner's selector switch box assembly (2). Discard lockwire.
- 5 Remove two hex nuts (9) and two seals (10) to remove two indicator lights (11). Remove two hex nuts (12). Discard seals.
- 6 Remove three hex nuts (13), three washers (14), three key washers (15), and three switch guards (16) from three toggle switches (17). Remove toggle switches and separate box (18) from gasket (19). Discard gasket.
- 7 Remove three hex nuts (20) and three packings (21) from three toggle switches (17). Discard packings.



- 8 Remove four machine screws (22), four lockwashers (23), and protective dust cap (24). This will release gasket (25), collimator connector (26), four hex nuts (27), and four flat washers (28). Discard gasket and lockwashers.
- 9 Remove four machine screws (29), four lockwashers (30), gasket (31), four hex nuts (32), and four flat washers (33) from connector (34). Discard gasket and lockwashers.



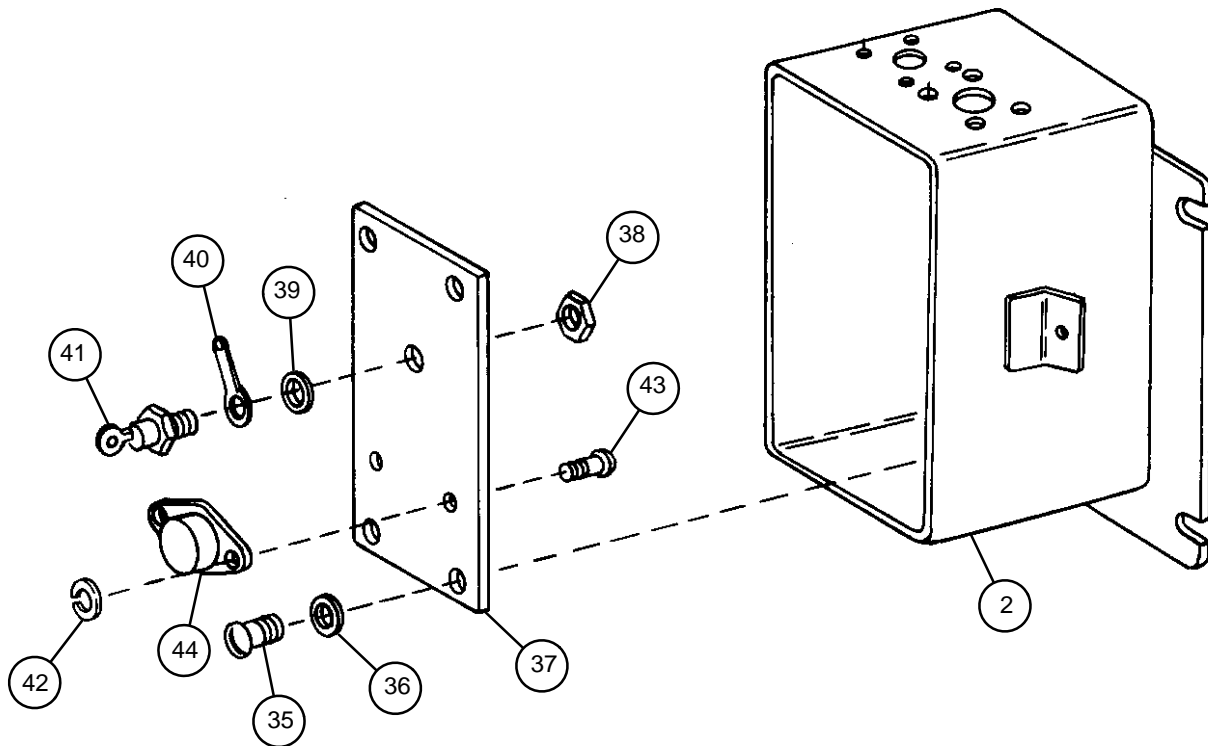
## 8-12 GUNNER'S SELECTOR SWITCH BOX ASSEMBLY — CONTINUED

### b. Disassembly — Continued

- 10 Remove four machine screws (35) and four lockwashers (36) from blank panel (37). Separate blank panel from gunner's selector switch box assembly (2). Discard lockwashers.
- 11 Remove hex nut (38). This will release lockwasher (39), lug terminal (40), and semi-conductor device (41) from blank panel (37). Discard lockwasher.
- 12 Remove two lockwashers (42), two machine screws (43), and circuit breaker (44) from blank panel (37). Discard lockwashers.

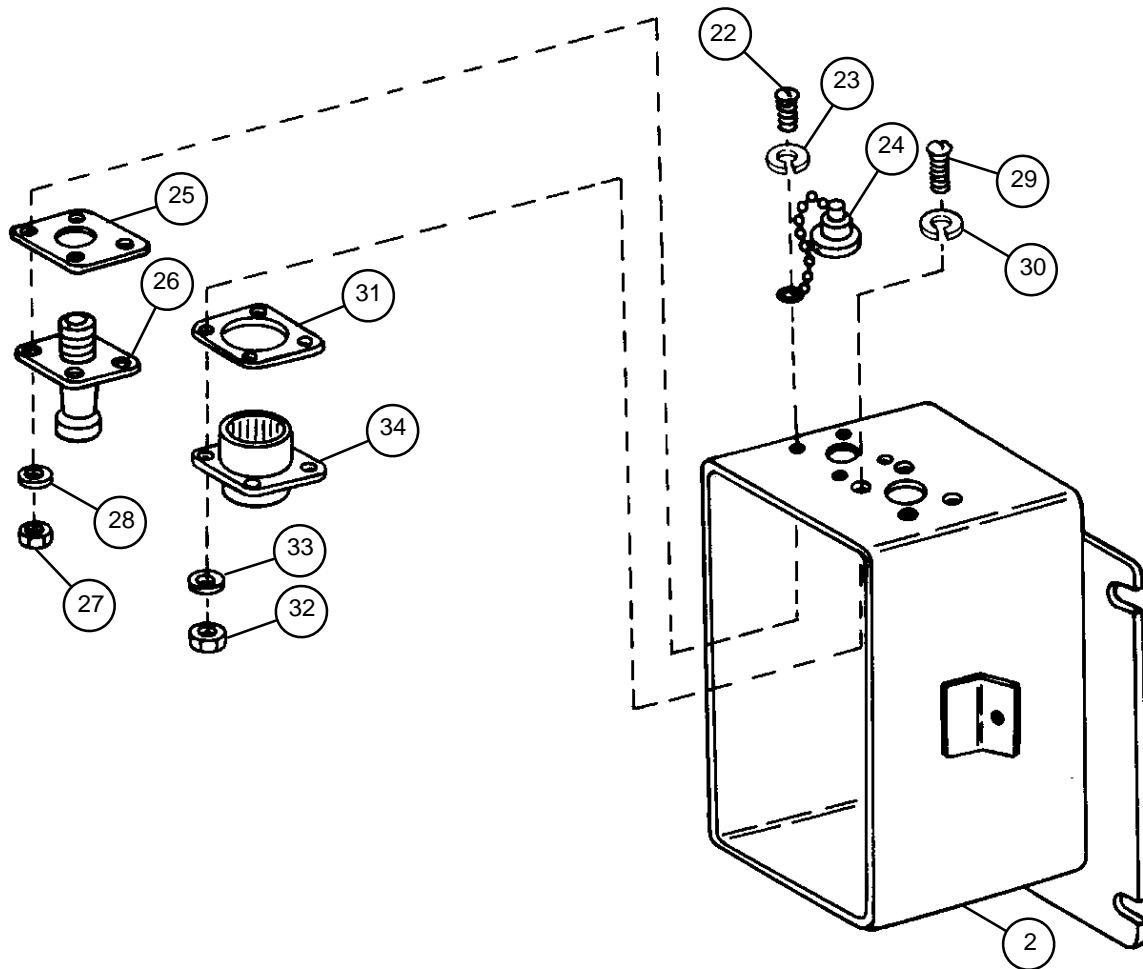
### c. Assembly

- 13 Using two machine screws (43) and two new lockwashers (42), attach circuit breaker (44) to blank panel (37).
- 14 Insert semi-conductor device (41) through lug terminal (40), new lockwasher (39), and blank panel (37). Attach semi-conductor device to blank panel using hex nut (38).
- 15 Aline four screw holes on blank panel (37) with four screw holes inside gunner's selector switch box assembly (2). Using four new lockwashers (36) and four machine screws (35), attach blank panel to gunner's selector switch box assembly.





- 16 Install one new lockwasher (23) and one machine screw (22) to secure protective dust cap (24) and three new lockwashers (23) and three machine screws (22) into top of gunner's selector switch box assembly (2).
- 17 Install new gasket (25) on collimator connector (26) and attach with four machine screws (22), four flat washers (28), and four hex nuts (27).
- 18 Install four new lockwashers (30) and four machine screws (29) into top of gunner's selector switch box assembly (2).
- 19 Install new gasket (31) on connector (34). Using four flat washers (33) and four hex nuts (32), fasten gasket (31) to four new lockwashers (30) and four machine screws (29) on top of gunner's selector switch box assembly (2).



**8-12 GUNNER'S SELECTOR SWITCH BOX ASSEMBLY — CONTINUED**

**c. Assembly — Continued**

- 20 Install three new packings (21) and three hex nuts (20) on three toggle switches (17).
- 21 Aline holes of new gasket (19) and box (18). Insert three toggle switches (17) through three vertical holes in gasket and box. Install three switch guards (16), three key washers (15), three washers (14), and three hex nuts (13) on toggle switches (17).
- 22 Install two hex nuts (12) on two indicator lights (11).
- 23 Install two indicator lights (11) with two new seals (10) and two hex nuts (9).
- 24 Install clamp (8), cap screw (7), and new lockwire (6) on gunner's selector switch box assembly (2).
- 25 Connect internal wiring in gunner's selector switch box assembly (2).

WIRING CHART

		WIRE		FROM		TO		LUG TERMINAL	
ITEM	SIZE AWG	SPEC	LENGTH	UNIT	TERM.	UNIT	TERM.	MS25036 -xxx	NO. REQD
1	12	*	As reqd	J2	P	CB1	A	-156	1
2	12	*	As reqd	CB1	B	S1	3	-156,-111	1 EA
3	20	*	As reqd	S1	3	J1	A	-101	1
4	20	*	As reqd	CB1	B	DS1	3	-149	1
5	16	*	As reqd	S1	2	S2	2	-106	2
6	20	*	As reqd	S1	2	DS1	2	-101	1
7	16	*	As reqd	S2	1	J2	A	-106	1
8	20	*	As reqd	J2	N	CR1	ANODE	--	--
9	20	*	As reqd	J1	B	DS1	1	--	--
10	20	*	As reqd	DS1	1	DS2	1	--	--
11	20	*	As reqd	DS2	1	CR1	ANODE	--	--
12	16	*	As reqd	J2	F	CB1	B	-153	1
13	20	*	As reqd	DS1	3	DS2	3	--	--
14	16	*	As reqd	S3	3	J2	C	-106	1
15	16	*	As reqd	S3	6	J2	6	-106	1
16	20	*	As reqd	S3	6	CR1	CATHODE	-101	1
17	20	*	As reqd	S3	6	DS2	2	-101	1
18	16	*	As reqd	S2	2	S3	2	-106	2
19	16	*	As reqd	S2	2	S3	5	-106	2
20	16	*	As reqd	S3	5	J2	E	-106	1

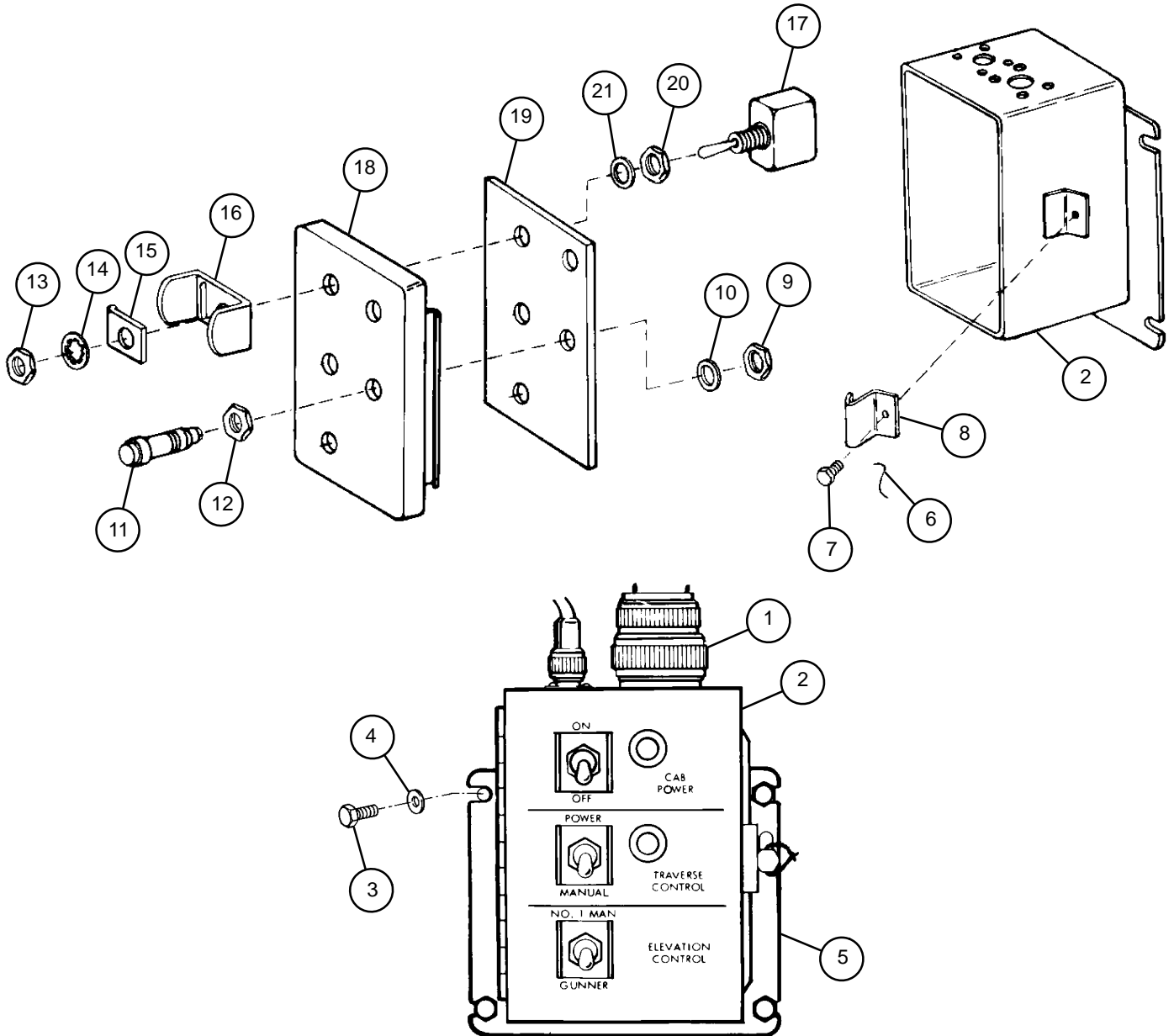
\*NOTE: HW-C-12-(19)-U-9, MW-C-16-(19)-U-9, and MW-C-20-(7)-U-9.

**d. Testing**

Using multimeter, test electrical circuit for continuity.

**e. Installation**

- 26 Aline four screw holes on box mount (5) with screw holes on gunner's selector switch box assembly (2).
- 27 Install four flat washers (4) and four cap screws (3).
- 28 Connect J2 connector harness (1), wire 100, to gunner's selector switch box assembly (2).



## 8-13 POWER RELAY BOX ASSEMBLY

- This task covers:
- a. Removal
  - b. Disassembly
  - c. Assembly
  - d. Installation

### INITIAL SETUP

#### Tools

Artillery and turret mechanic's tool kit  
(SC 5180-95-CL-A12)

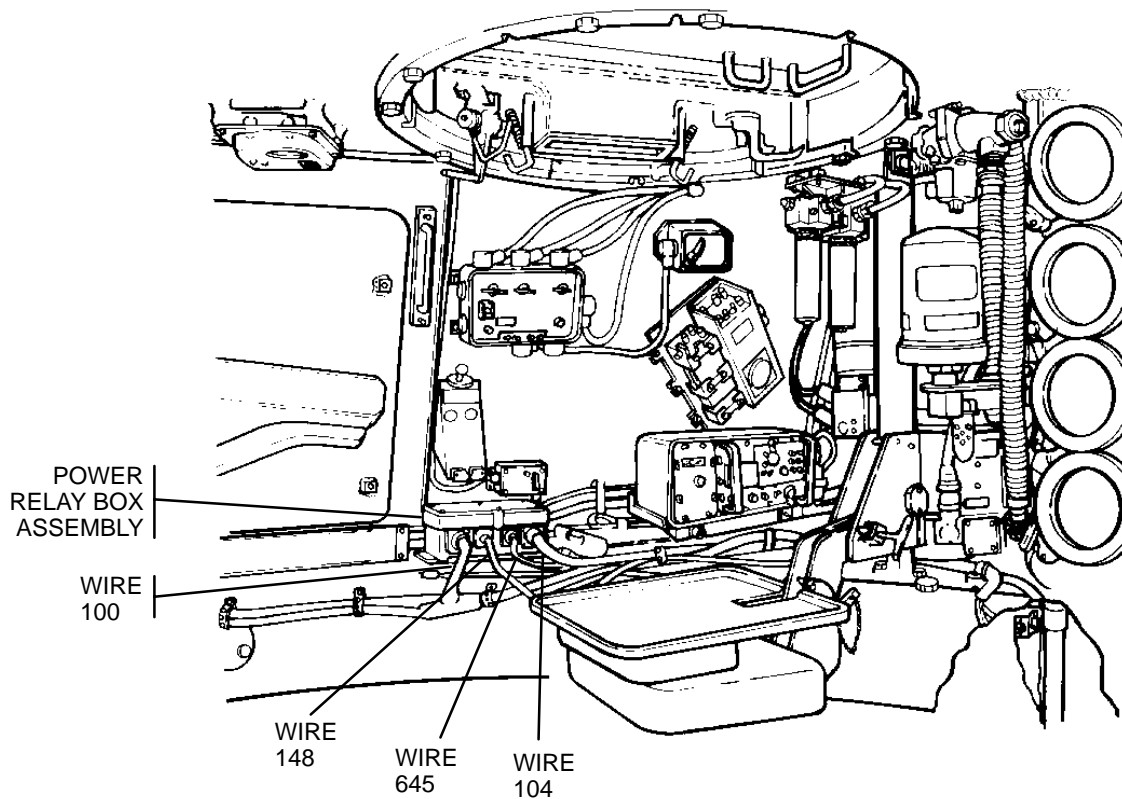
#### Materials/Parts

Gasket (item 101, Appx G)  
Gasket (item 102, Appx G)  
Gasket (item 179, Appx G)  
Gaskets (2) (item 103, Appx G)  
Lockwasher (item 55, Appx G)  
Lockwashers (8) (item 53, Appx G)

Lockwashers (4) (item 54, Appx G)  
Lockwashers (2) (item 56, Appx G)  
Lockwashers (5) (item 64, Appx G)  
Lockwashers (8) (item 76, Appx G)  
Lockwashers (6) (item 78, Appx G)  
Lockwashers (2) (item 87, Appx G)

#### Equipment Condition

Disconnect batteries (TM 9-2350-311-20-1)  
NBC power switch box removed on M109A4/M109A5  
howitzers (para 17-4)

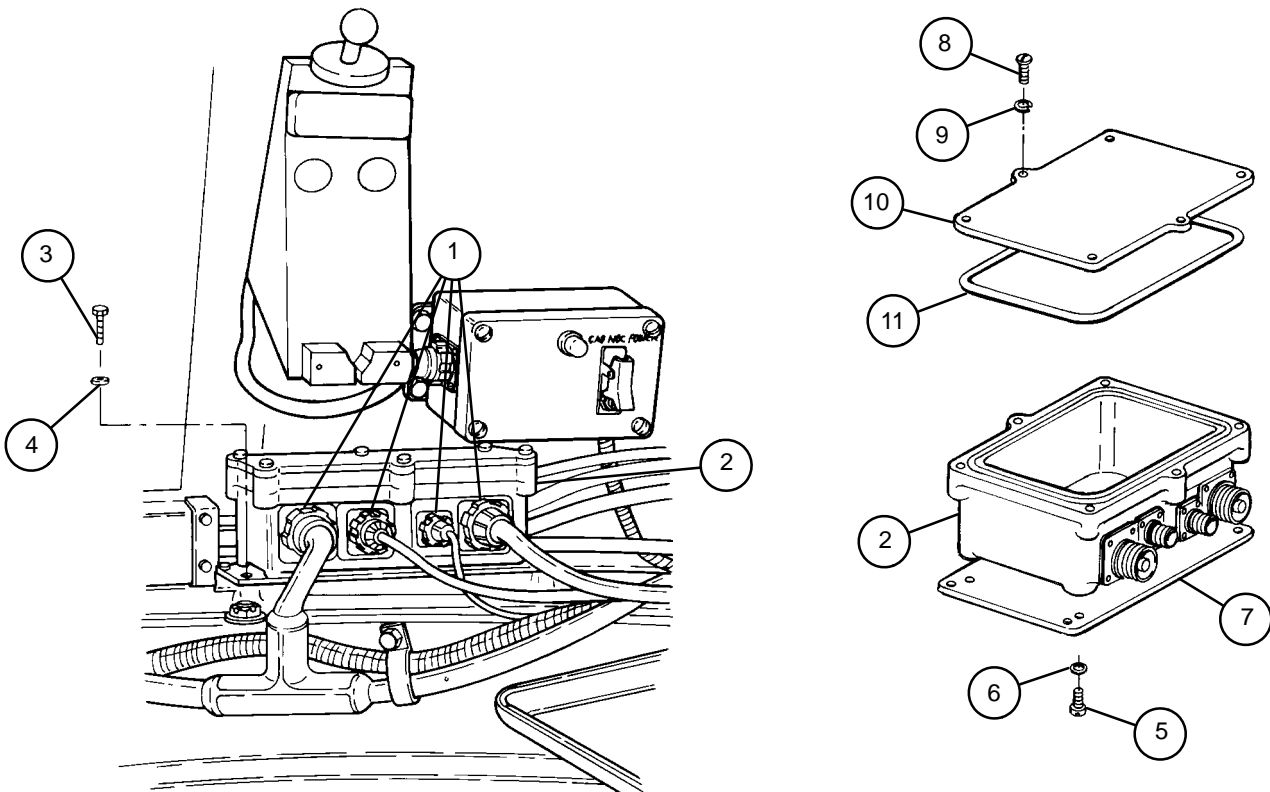


**a. Removal**

- 1 Disconnect four connectors (1), wires 100, 104, 148, and 645, from cab power relay box assembly (2).
- 2 Remove four cap screws (3) and four flat washers (4) securing cab power relay box assembly (2) to vehicle.

**b. Disassembly**

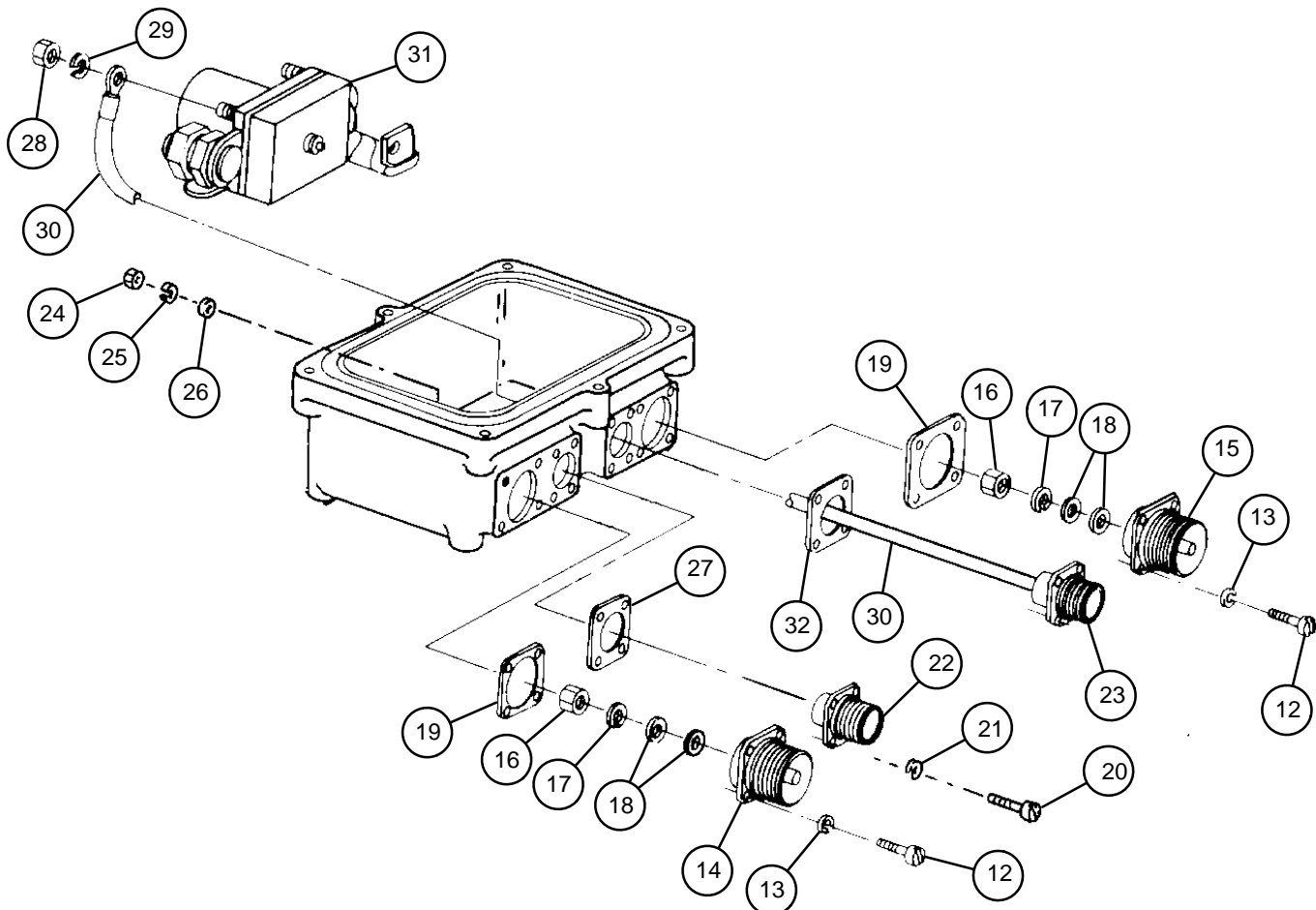
- 1 Remove four cap screws (5), four flat washers (6), and mounting plate (7) from cab power relay box assembly (2).
- 2 Remove six bolts (8), six lockwashers (9), distribution cover (10), and gasket (11) from cab power relay box assembly (2). Discard gasket and lockwashers.



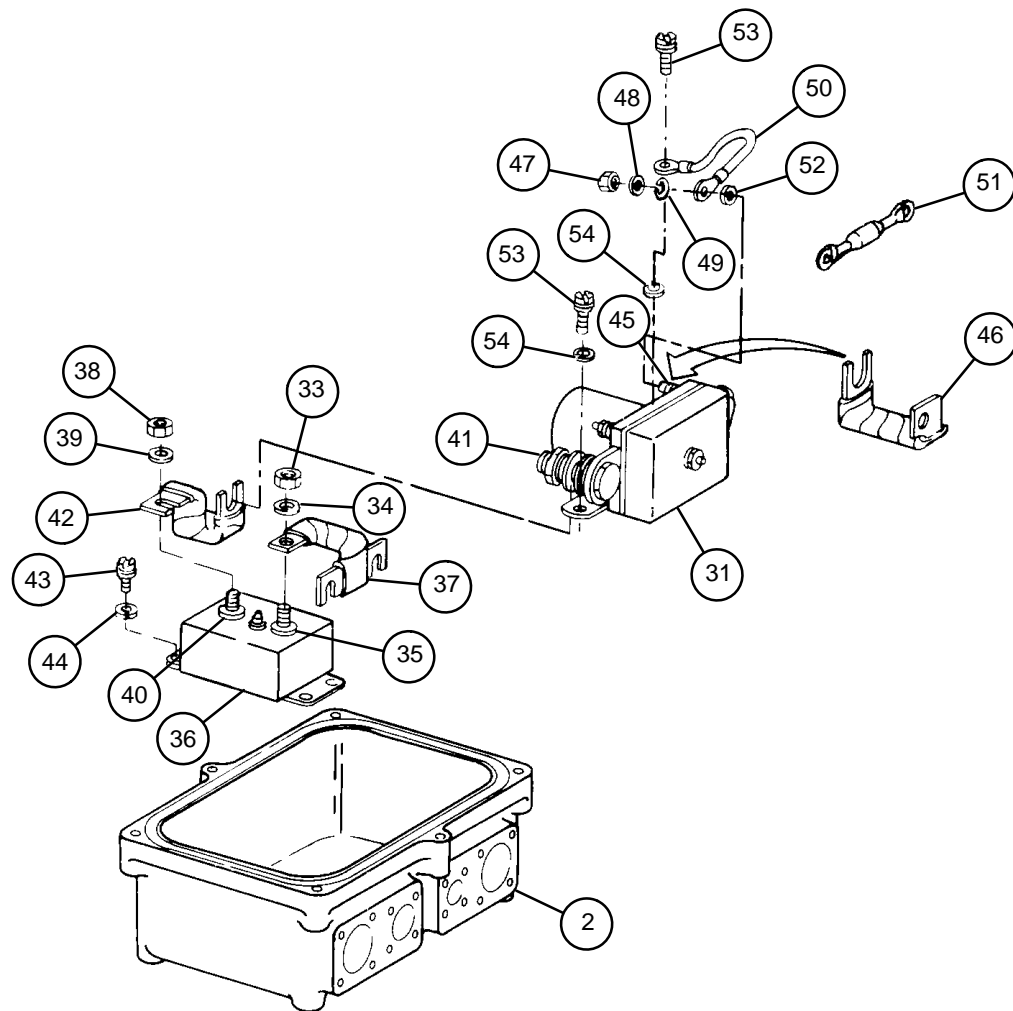
## 8-13 POWER RELAY BOX ASSEMBLY — CONTINUED

### b. Disassembly — Continued

- 3 Remove eight machine screws (12) and eight lockwashers (13) from two connectors (14 and 15). Discard lockwashers.
- 4 Remove hex nut (16), one lockwasher (17), and two flat washers (18) from each connector (14 and 15). This will release gasket (19) from each connector. Discard gaskets and lockwashers.
- 5 Remove eight machine screws (20) and eight lockwashers (21) from two connectors (22 and 23). Discard lockwashers.
- 6 Remove hex nut (24), lockwasher (25), and flat washer (26) from connector (22). This will release gasket (27). Discard gasket and lockwasher.
- 7 Remove hex nut (28), lockwasher (29), and electrical lead (30) from electromagnetic relay (31). Remove connector (23) with electrical lead (30) attached to release gasket (32). Discard gasket and lockwasher.



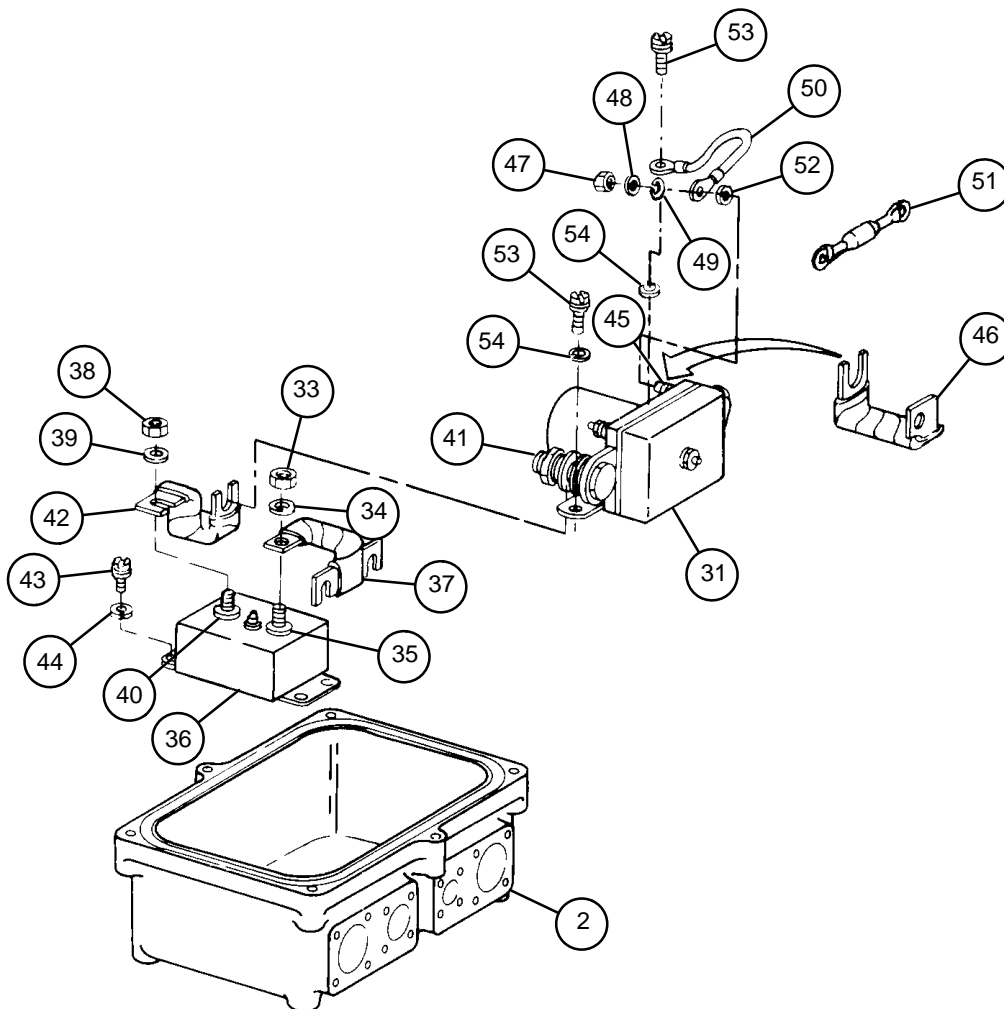
- 8 Remove hex nut (33) and lockwasher (34) from post (35) on circuit breaker (36). This will release terminal connecting link (37). Discard lockwasher.
- 9 Remove hex nut (38) and lockwasher (39) from post (40) on circuit breaker (36). Loosen hex nut (41) on electromagnetic relay (31). Slide power relay shunt (42) off electromagnetic relay (31) to remove.
- 10 Remove four machine screws (43) and four lockwashers (44) to remove circuit breaker (36) from cab power relay box assembly (2). Discard lockwashers.
- 11 Loosen hex nut (45) on electromagnetic relay (31). Slide conductor bus (46) off electromagnetic relay (31) to remove.
- 12 Remove two hex nuts (47), two flat washers (48), two lockwashers (49), one end of electrical lead (50), semi-conductor (51), and two flat washers (52) from electromagnetic relay (31). Discard lockwashers.
- 13 Remove two machine screws (53), other end of electrical lead (50), and two lockwashers (54) to release electromagnetic relay (31) from cab power relay box assembly (2). Discard lockwashers.



## 8-13 POWER RELAY BOX ASSEMBLY — CONTINUED

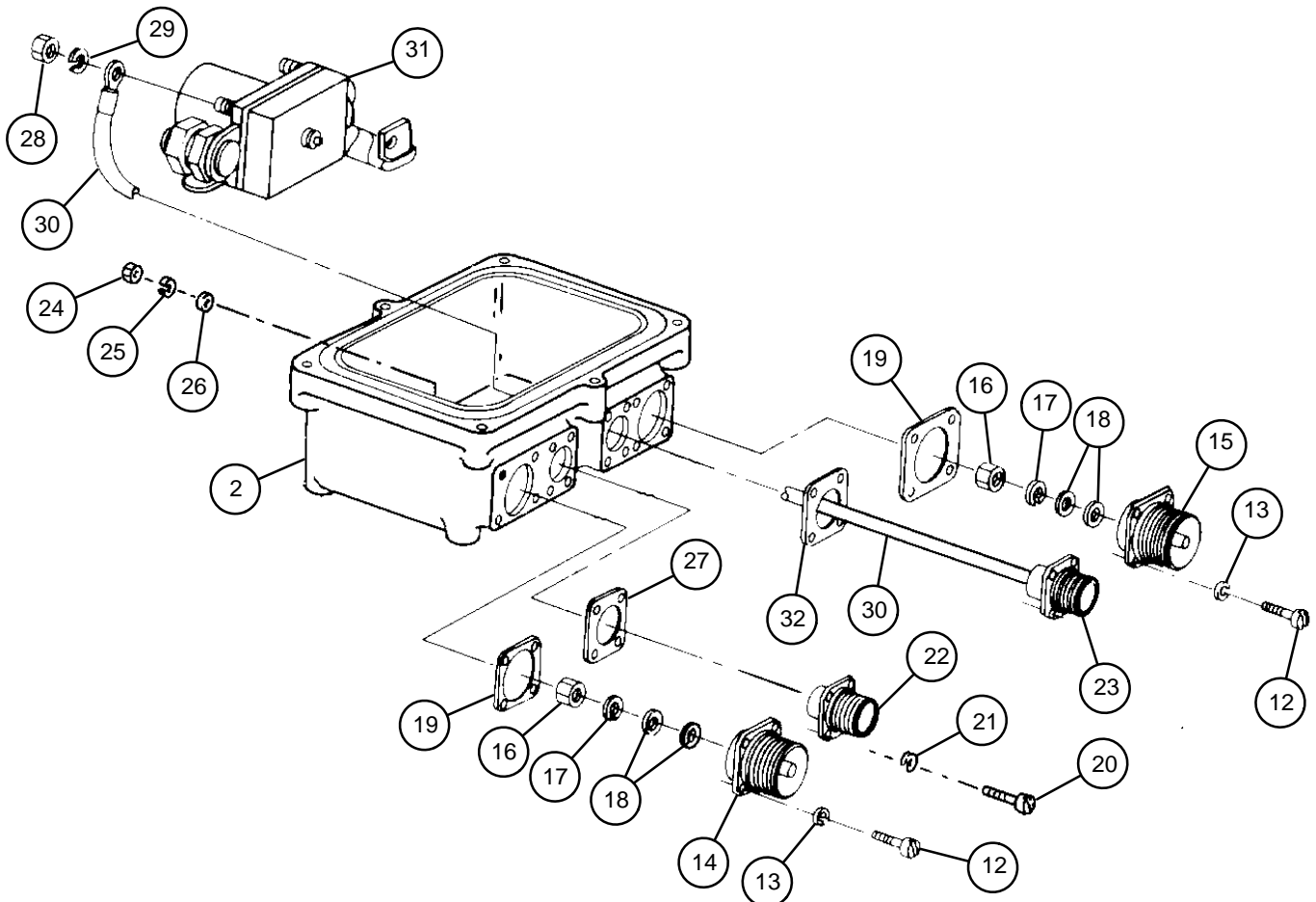
### c. Assembly

- 1 Install the following on electromagnetic relay (31): two flat washers (52), semi-conductor (51), one end of electrical lead (50), two new lockwashers (49), two flat washers (48), and two hex nuts (47).
- 2 Aline two mounting holes on electromagnetic relay (31) with holes in cab power relay box assembly (2). Install electromagnetic relay (31) on cab power relay box assembly using two new lockwashers (54), other end of electrical lead (50), and two machine screws (53).
- 3 Install circuit breaker (36) in cab power relay box assembly (2) using four machine screws (43) and four new lockwashers (44).
- 4 Slide one end of power relay shunt (42) onto post (40) on circuit breaker (36). Install hex nut (38) and new lockwasher (39) on post (40). Slide other end of power relay shunt (42) onto relay load terminal post and tighten hex nut (41) and new lockwasher (45).





- 5 Using hex nut (33) and new lockwasher (34), install terminal connecting link (37) on post (35) of circuit breaker (36).
- 6 Slide conductor bus (46) onto electromagnetic relay (31) and tighten hex nut (45) on relay load terminal post.
- 7 Position new gasket (32) over screw holes and insert connector (23) with attached electrical lead (30) into cab power relay box assembly (1). Install four machine screws (20) and four new lockwashers (21) on connector (23). Using hex nut (28) and new lockwasher (29), install electrical lead (30) on electromagnetic relay (31).
- 8 Position new gasket (27) over screw holes and insert connector (22) into cab power relay box assembly (2), and secure with four new lockwashers (21) and four machine screws (20). Aline connector (22) with prongs of terminal connecting link (37) and conductor bus (46). Install flat washer (26), new lockwasher (25), and hex nut (24).
- 9 Install new gasket (19), connector (14), four new lockwashers (13), and four machine screws (12). Aline connector (14) with prong of terminal connecting link (37) inside cab power relay box assembly (2). Connect connector (14) to terminal connecting link (37) using two flat washers (18), new lockwasher (17), and hex nut (16).
- 10 Install new gasket (19), connector (14), four new lockwashers (13), and four machine screws (12). Aline connector (15) with prong of conductor bus (46) inside cab power relay box assembly (2). Connect connector (15) to conductor bus (46) using two flat washers (18), new lockwasher (17), and hex nut (16).



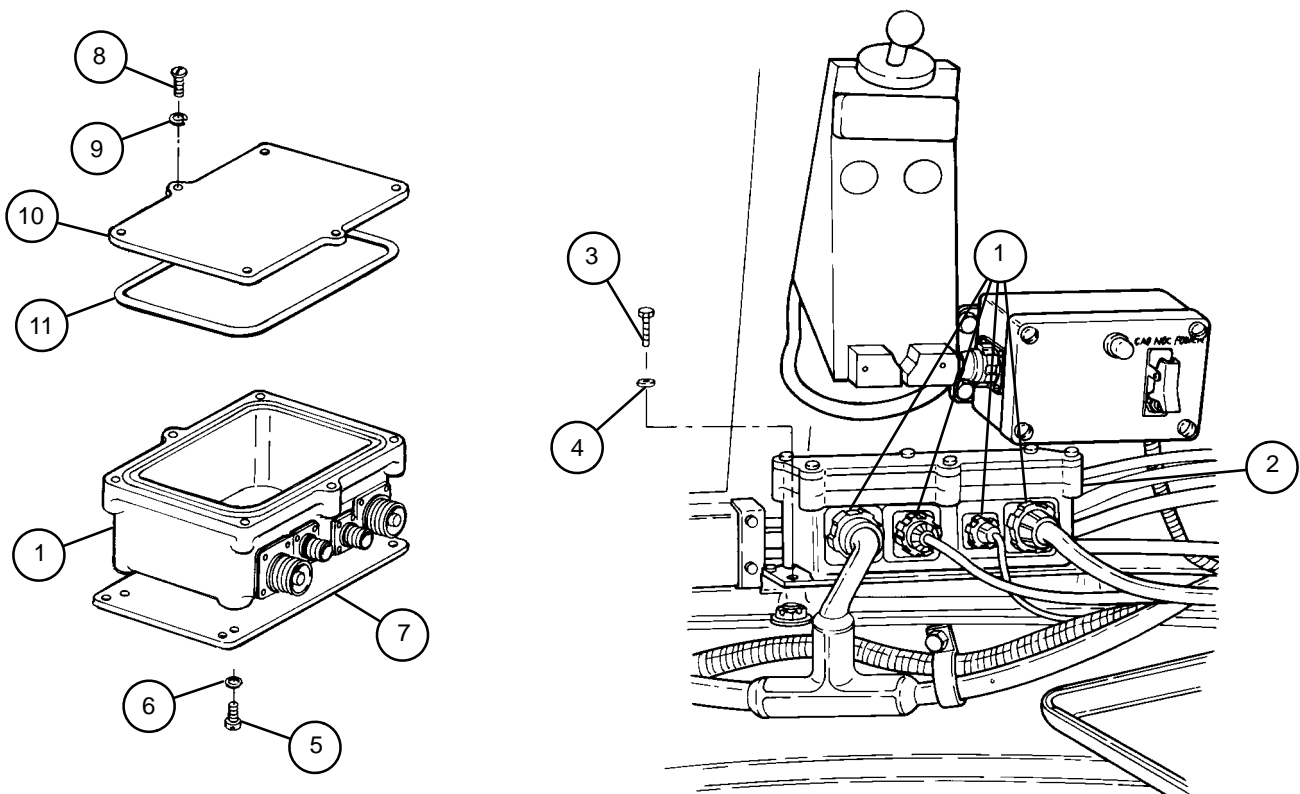
## 8-13 POWER RELAY BOX ASSEMBLY — CONTINUED

### c. Assembly — Continued

- 1 Install distribution cover (10) and new gasket (11) on cab power relay box assembly (2) using six bolts (8) and six new lockwashers (9).
- 2 Install mounting plate (7) on cab power relay box assembly (2) using eight cap screws (5) and eight flat washers (6).

### d. Installation

- 1 Install four cap screws (3) to secure cab power relay box assembly (2) to mount (4).
- 2 Connect four connectors (1), wires 100, 104, 148, and 645, at cab power relay box assembly (2).



**Section III. INTERCOMMUNICATIONS SYSTEM**

**8-14 POWER RELAY BOX TO INTERCOM POWER SUPPLY LEAD ASSEMBLY**

- This task covers:
- |            |                         |
|------------|-------------------------|
| a. Removal | b. Disassembly/Assembly |
| c. Testing | d. Installation         |

**INITIAL SETUP**

Test Equipment

Multimeter (item 6, Appx H)

Tools

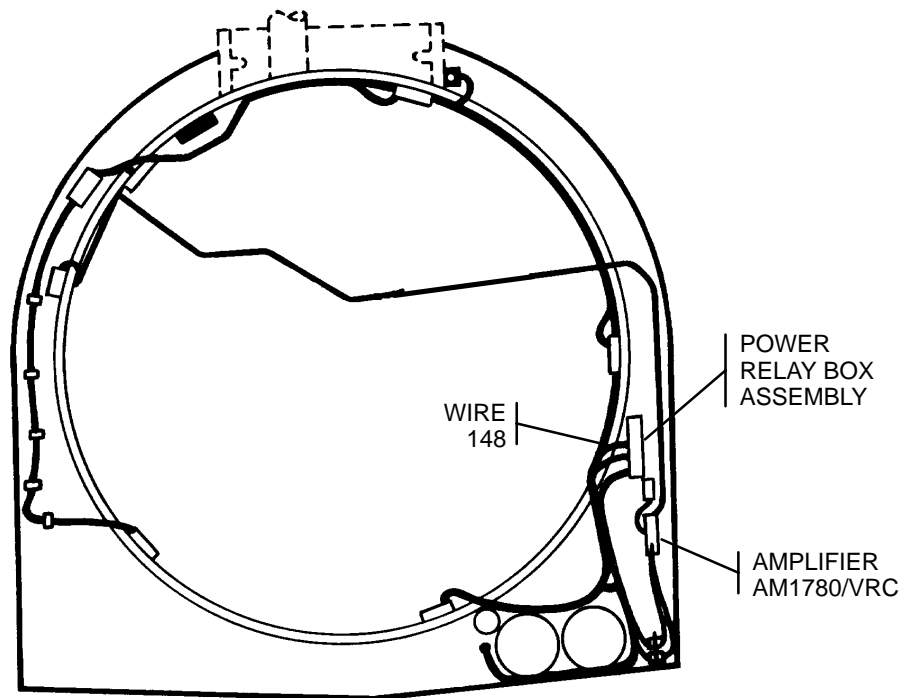
Artillery and turret mechanic's tool kit  
(SC 5180-95-CL-A12)

Materials/Parts

Lockwashers (2) (item 86, Appx G)

Equipment Condition

Disconnect batteries (TM 9-2350-311-20-1)



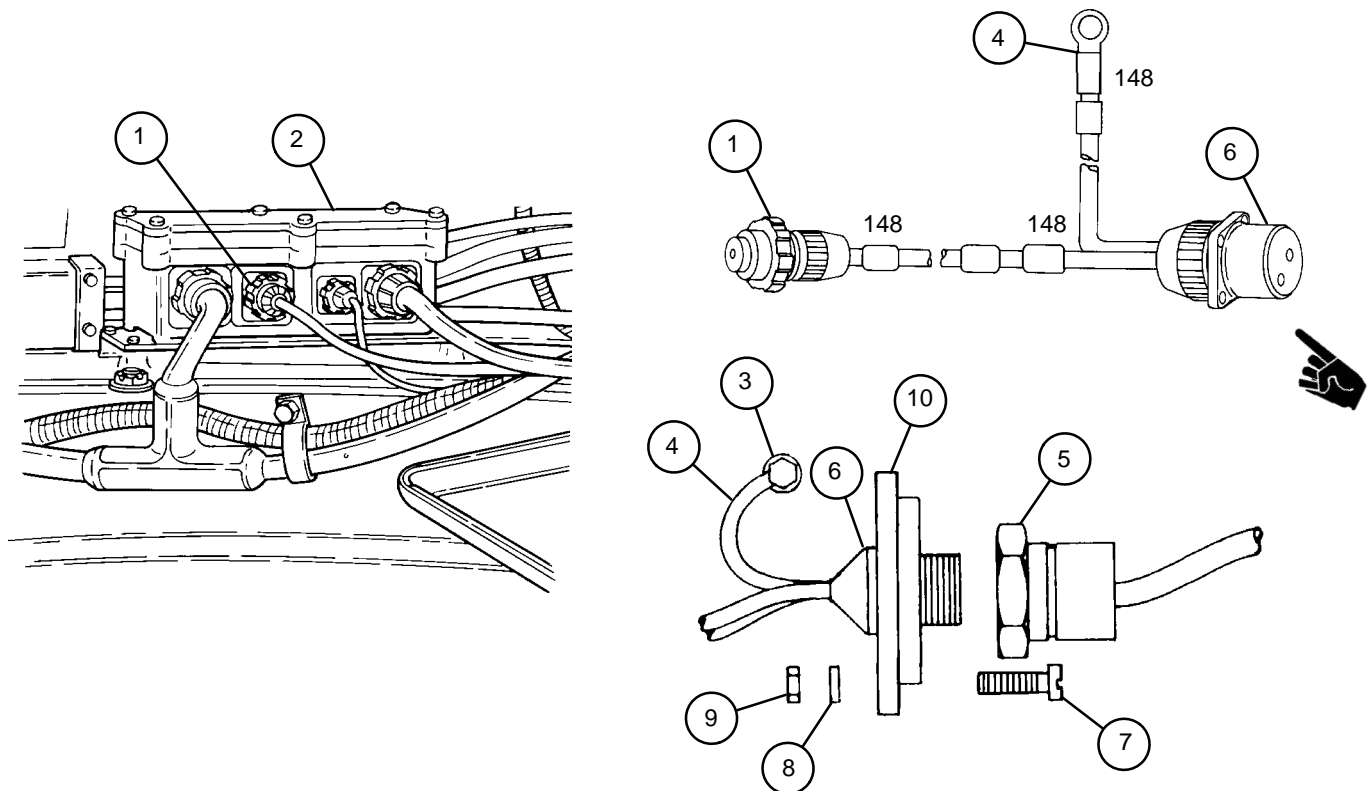
## 8-14 POWER RELAY BOX TO INTERCOM POWER SUPPLY LEAD ASSEMBLY — CONTINUED

### a. Removal

- 1 Disconnect connector (1), wire 148, from power relay box assembly (2).
- 2 Remove hex head bolt (3) securing ground lead (4), wire 148, to rear of cab.
- 3 Disconnect connector (5) of wire 148 from connector (6).
- 4 Remove four machine screws (7), four flat washers (8), and four hex nuts (9) securing connector (6) to mounting bracket (10).
- 5 Remove two harness clamps (11), two hex head screws (11.1), two lockwashers (11.2), two flat washers (11.3), and power relay box to intercom power supply lead assembly (12) from cab. Discard lockwashers.
- 6 Deleted.

### b. Disassembly/Assembly

See repair procedures for harnesses, plugs, and terminals (para 8-1).

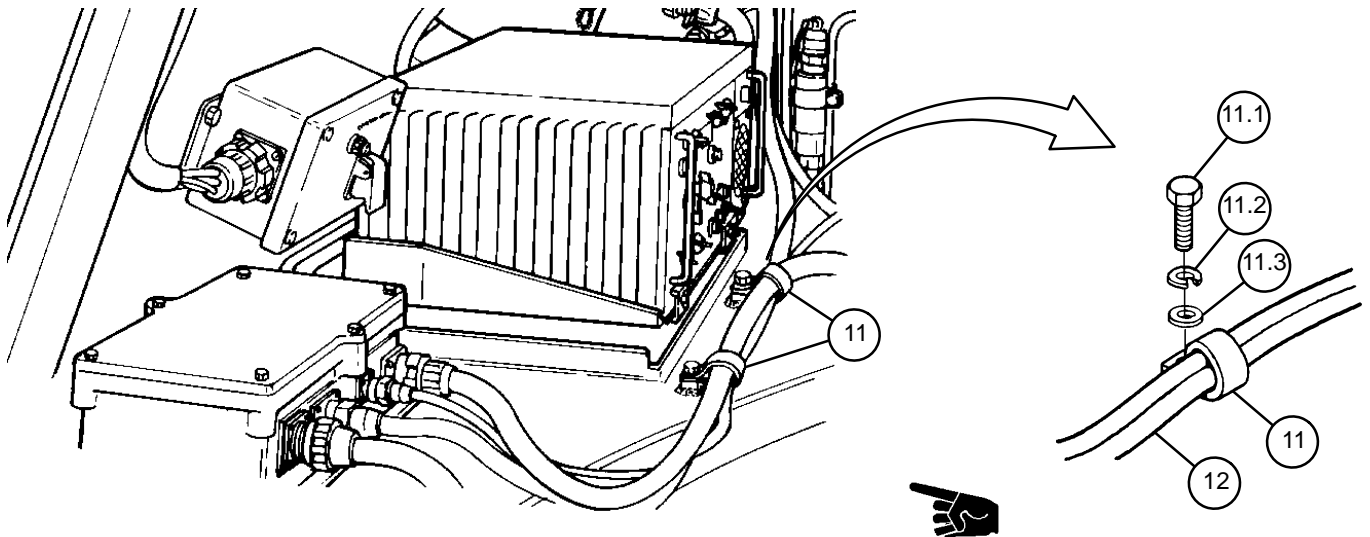


### c. Testing

Using multimeter, test power relay box to intercom power supply lead assembly for continuity.

### d. Installation

- 1 Secure power relay box to intercom power supply lead assembly (12) to cab using two hex head screws (11.1), two new lockwashers (11.2), two flat washers (11.3), and two harness clamps (11).
- 2 Install connector (6) on mounting bracket (10) using four machine screws (7), four flat washers (8), and four hex nuts (9).
- 3 Connect connector (5) of wire 148 to connector (6).
- 4 Using hex head bolt (3), secure ground lead (4), wire 148, to rear of cab.
- 5 Connect connector (1), wire 148, to power relay box assembly (2).



## 8-15 POWER SYSTEM WIRING HARNESS (INTERCOM)

This task covers: a. Removal b. Disassembly/Assembly  
c. Installation

### INITIAL SETUP

Tools

Artillery and turret mechanic's tool kit  
(SC 5180-95-CL-A12)

Materials/Parts

Lockwasher (item 86, Appx G)

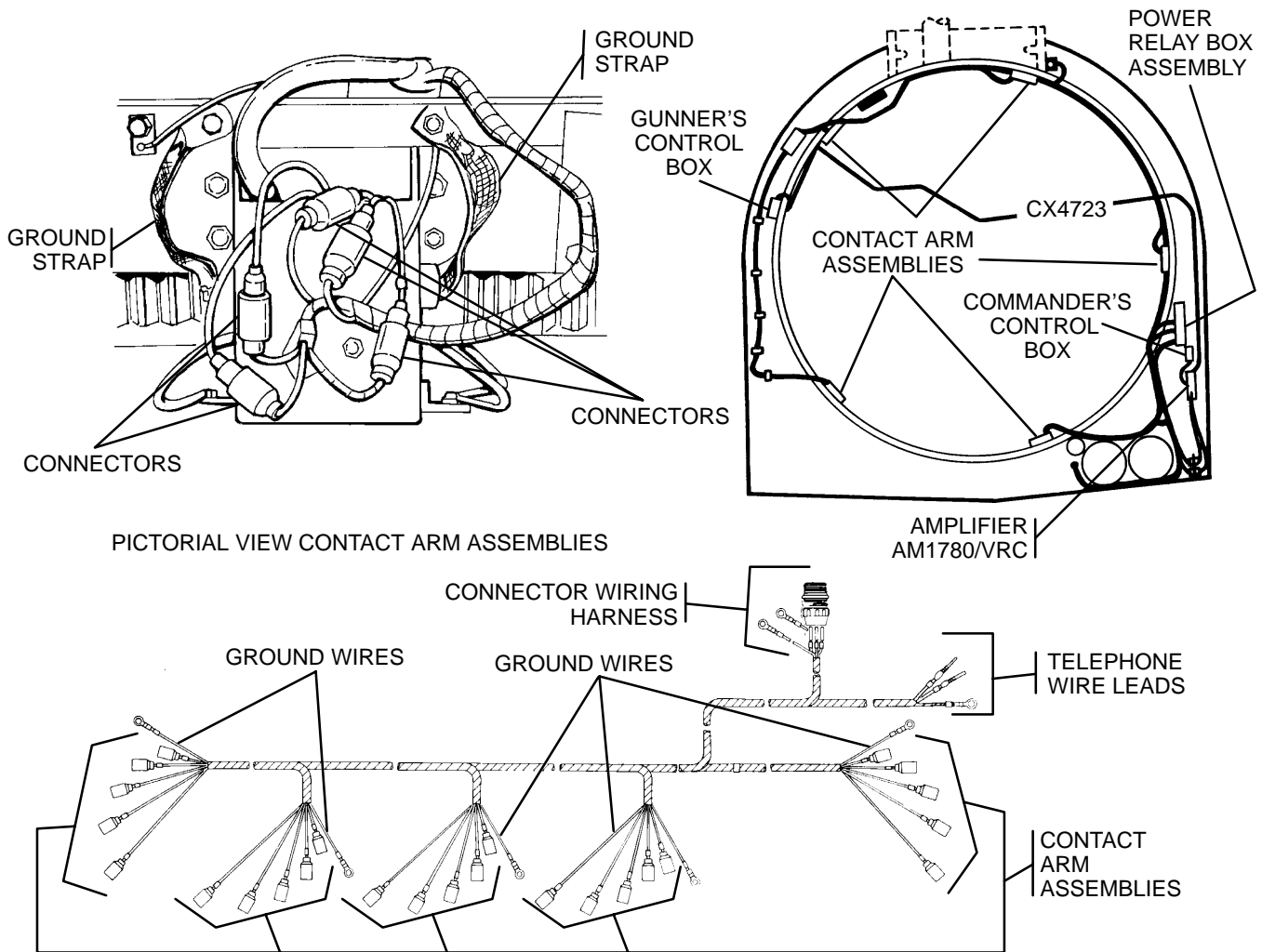
Tape, black (electrical) (item 39, Appx D)

Equipment Condition

Disconnect batteries (TM 9-2350-311-20-1)

Personnel Required

2



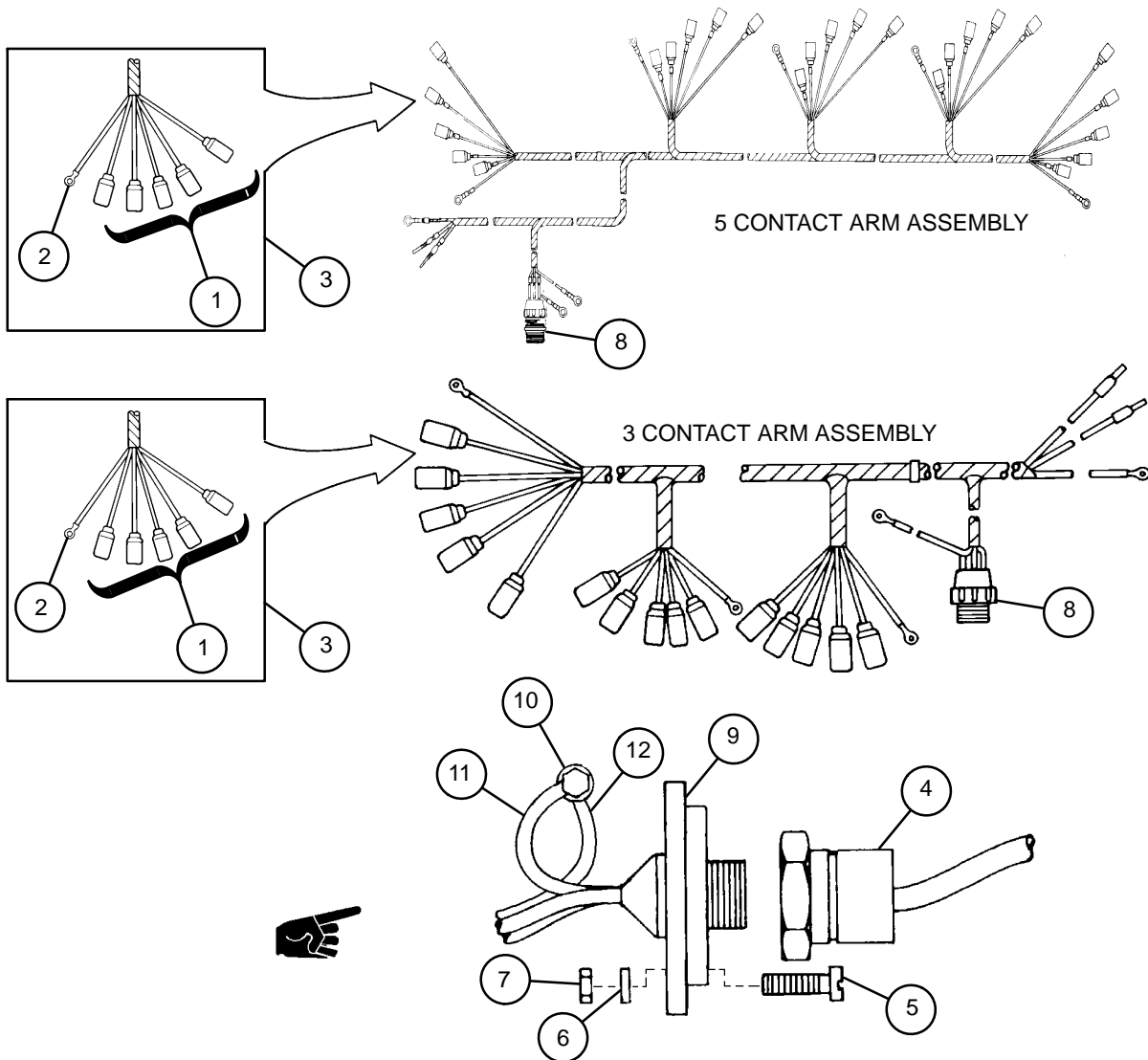
**a. Removal**

- 1 Disconnect five connectors (1) and ground lug terminals (2) at each contact arm assembly (3).

**NOTE**

Between the cab traverse lock and the race ring below the selector valve assembly, the power system wiring harness (intercom) is taped into a wiring bundle with the panoramic telescope to dome light lead assembly. To remove the power system wiring harness (intercom), remove the electrical tape. Replace tape as needed during installation.

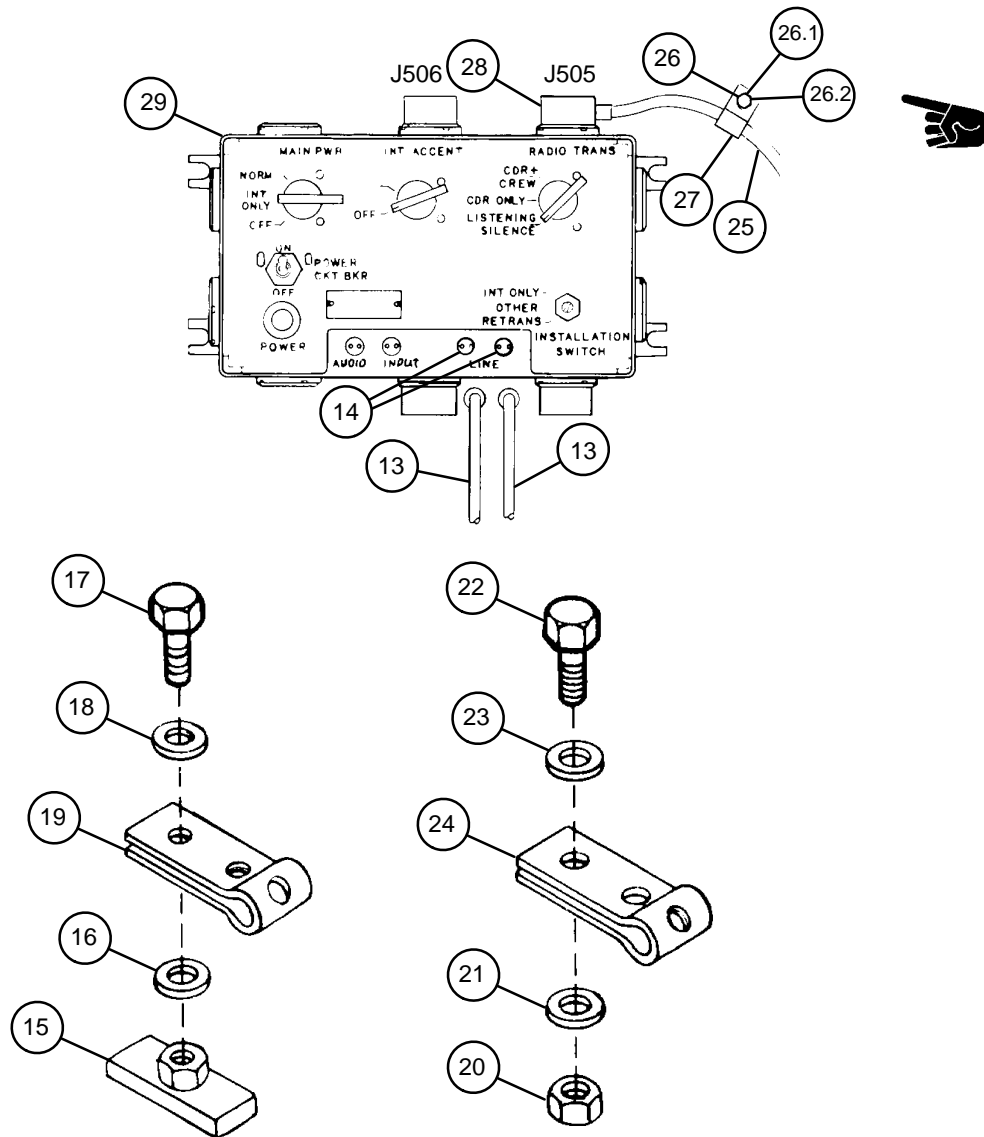
- 2 Unscrew connector (4). Remove four machine screws (5), four flat washers (6), and four hex nuts (7) from connector wiring harness (8) and mounting bracket (9).
- 3 Remove cap screw (10), ground lead (11), and telephone ground wire (12) from cab body.
- 4 Remove wiring harness (8) from mounting bracket (9).



**8-15 POWER SYSTEM WIRING HARNESS (INTERCOM) — CONTINUED**

**a. Removal — Continued**

- 5 Deleted
- 6 Remove telephone wire leads L1 and L2 (13) from telephone wire lead terminals (14).
- 7 From the 20 welded on hex nuts (15), remove 20 flat washers (16), 20 cap screws (17), 20 flat washers (18), and 20 plastic attaching straps (19). Remove three hex nuts (20), three flat washers (21), three cap screws (22), three flat washers (23), three plastic attaching straps (24), and wiring harness (25).
- 8 Remove bolt (26), lockwasher (26.1), flat washer (26.2), and plastic attaching strap (27). Discard lockwasher.
- 9 Disconnect cable CX9640 cable connector (28) from amplifier AM1780/VRC (29) at J505.

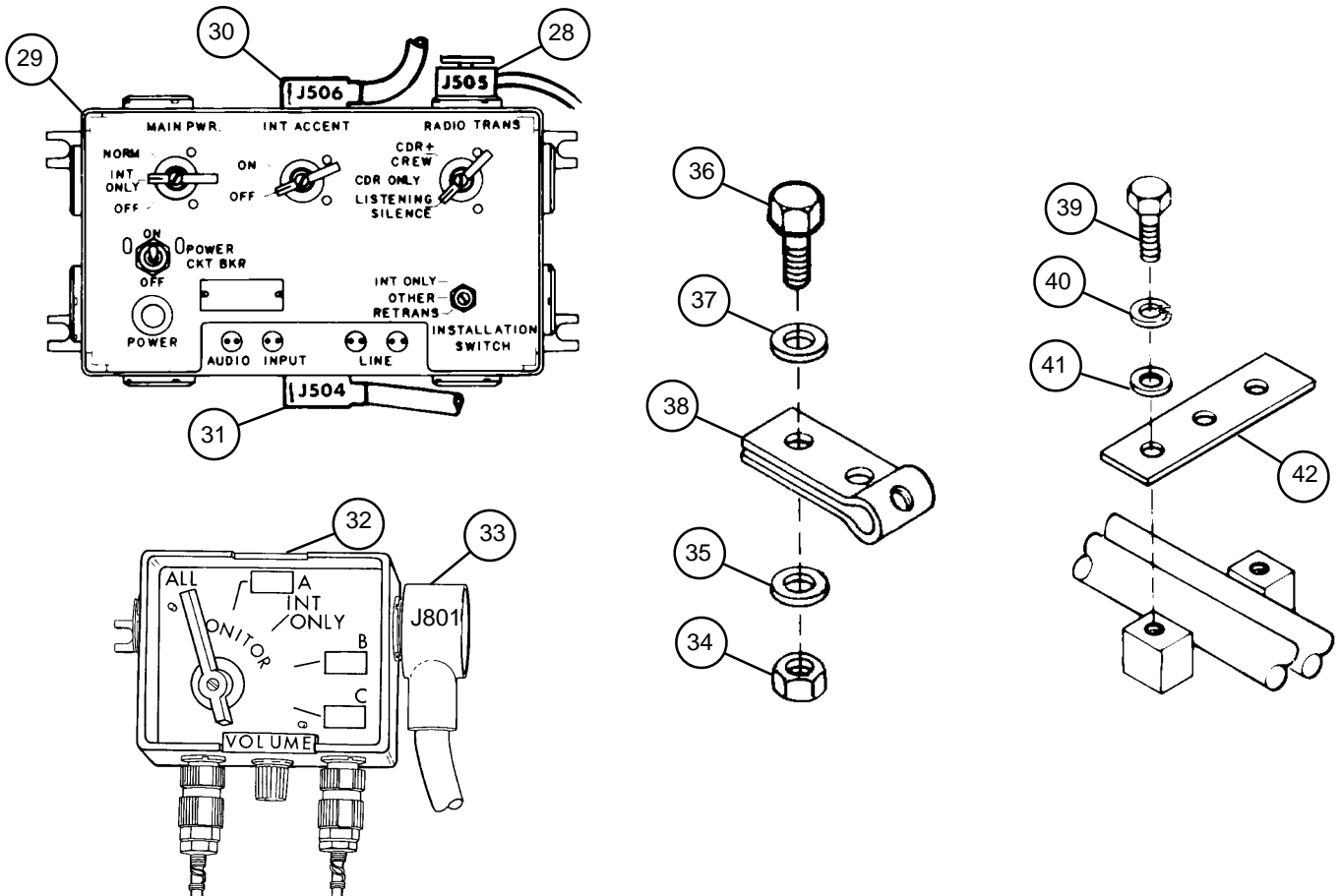




**NOTE**

- The procedure outlined in steps 10–13 should be followed only if the technician wants to disconnect all intercom wiring.
- Cable CX4723 on the amplifier AM1780/VRC runs to the commander's intercom control box at J801 or J804. Since J801 or J804 are wired in parallel, the technician can either remove cable at J801 or J804 on the commander's intercom control box and remove cable at J801 or J804 on the gunner's intercom control box.

- 10 Disconnect cable CX4723, gunner's (30), from amplifier AM1780/VRC (29) at J506.
- 11 Disconnect cable CX4723, commander's (31) from amplifier AM1780/VRC (29) at J504. Disconnect cable CX4723 commander's from commander's intercom control box C2298/VRC (32) at J801 (33).
- 12 Remove 16 hex nuts (34), 16 flat washers (35), 16 bolts (36), 16 flat washers (37), and 16 plastic attaching straps (38).
- 13 Remove bolt (39), lockwasher (40), flat washer (41), and plastic attaching strap (42). Discard lockwasher.



## 8-15 POWER SYSTEM WIRING HARNESS (INTERCOM) — CONTINUED

### b. Disassembly/Assembly

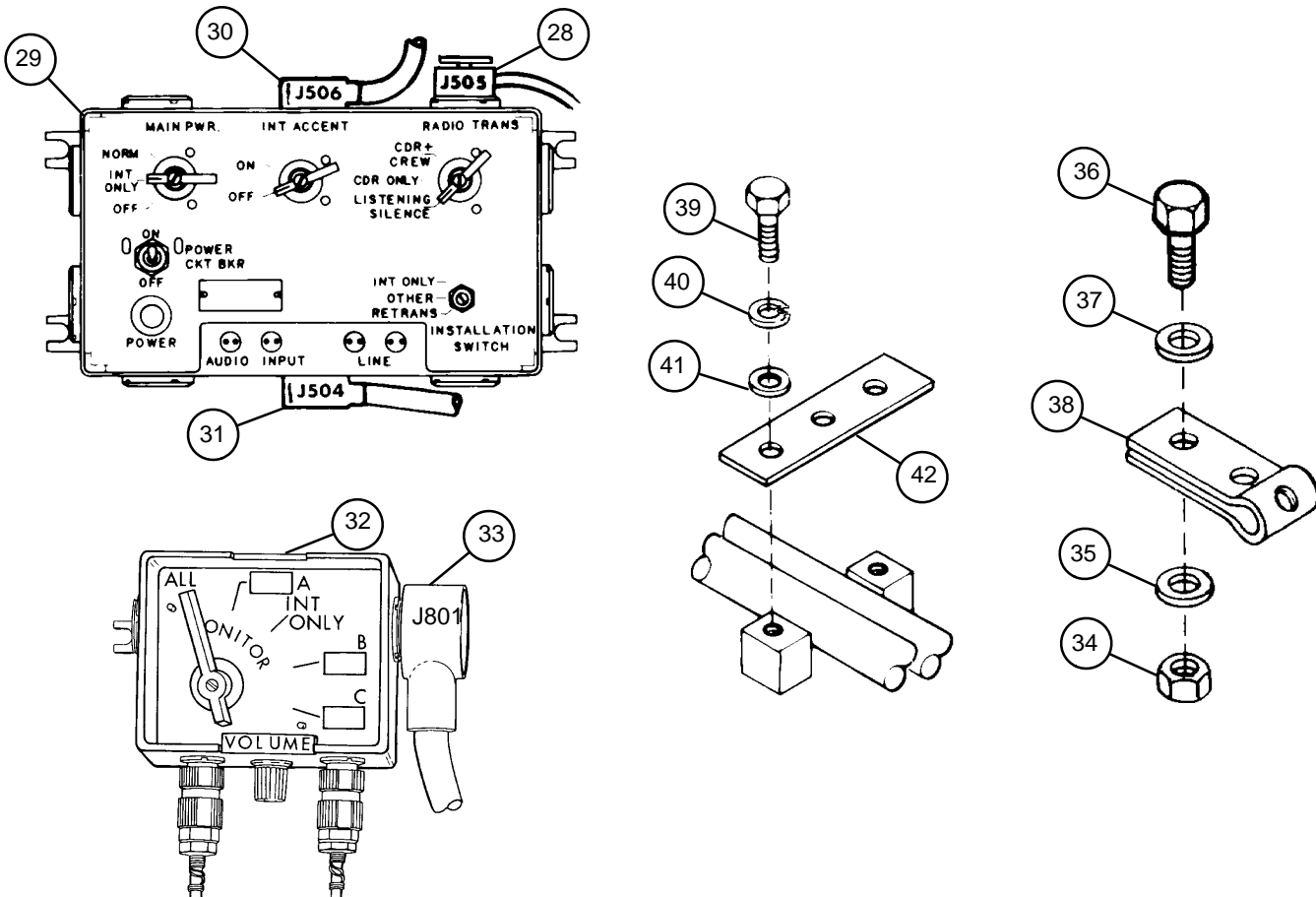
See repair procedures for harnesses, plugs, and terminals (para 8-1).

### c. Installation

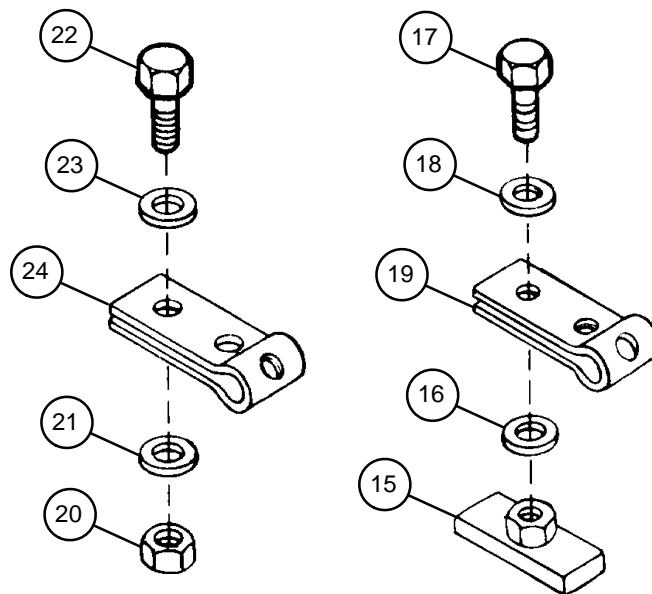
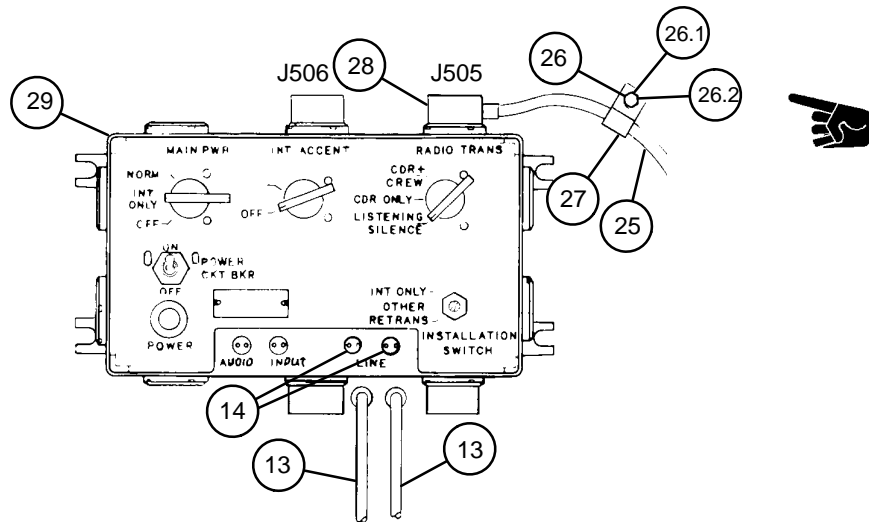
#### NOTE

If cables were not removed from the amplifier as described in the removal procedure of this paragraph (steps 10 through 13), begin this installation procedure with step 5.

- 1 Connect cable CX4723, commander's (31) to commander's intercom control box C2298/VRC (32) at J801 (33). Connect cable CX4723, commander's to amplifier AM1780/VRC (29) at J504.
- 2 Connect cable CX4723, gunner's (30) to amplifier AM1780/VRC (29) at J506.
- 3 Install plastic attaching strap (42), flat washer (41), new lockwasher (40), and bolt (39).
- 4 Install 16 plastic attaching straps (38), 16 flat washers (37), 16 bolts (36), 16 flat washers (35), and 16 hex nuts (34).
- 5 Connect cable CX9640 cable connector (28) to amplifier AM1780/VRC (29) at J505.



- 6 Install plastic attaching strap (27), flat washer (26.2), new lockwasher (26.1), and bolt (26).
- 7 Install wiring harness (25), three plastic attaching straps (24), three flat washers (23), three cap screws (22), three flat washers (21), and three hex nuts (20). Install 20 plastic attaching straps (19) 20 flat washers (18), 20 cap screws (17), 20 flat washers (16), to 20 welded on hex nuts (15).
- 8 Attach telephone wire leads L1 and L2 (13) to telephone wire lead terminals (14) on amplifier AM1780/VRC (29).
- 9 Deleted.



## 8-15 POWER SYSTEM WIRING HARNESS (INTERCOM) — CONTINUED

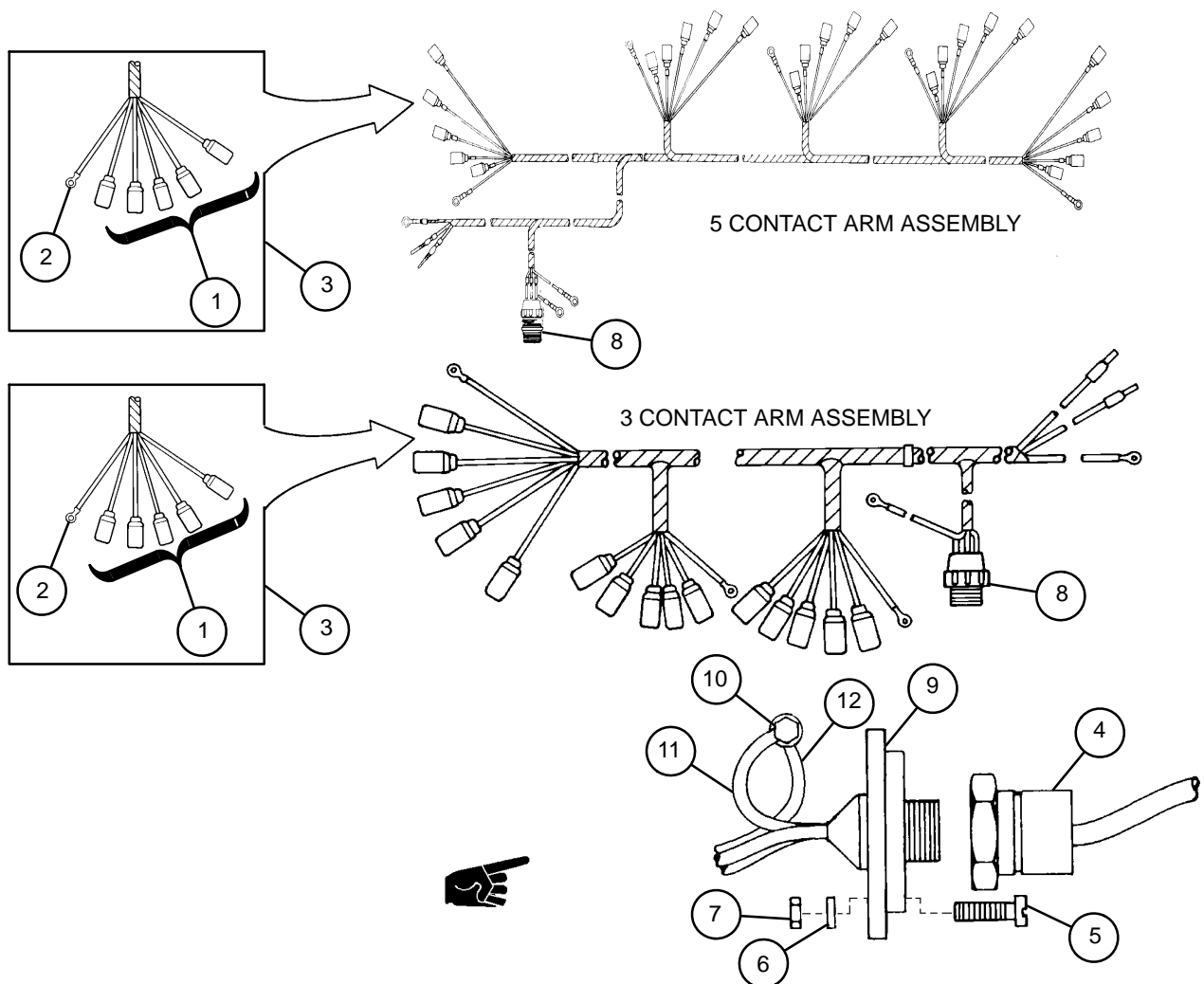
### c. Installation — Continued

- 10 Install connector wiring harness (8) on mounting bracket (9).
- 11 Install telephone ground wire (12), ground lead (11), and cap screw (10) to cab.
- 12 Install connector (4) on mounting bracket (9). Install four machine screws (5), four flat washers (6), and four hex nuts (7) on mounting bracket (9).
- 13 Tape connector wiring harness as required. Tape wiring bundles as necessary.

#### NOTE

After assembly, check to ensure wiring bundles will not be pinched by the commander's seat.

- 14 Connect five connectors (1) and ground lug terminals (2) at each contact arm assembly (3). Refer to chapter 9 on the contact arm assembly.





## 8-16 AMPLIFIER AND CONTROL BOX — CONTINUED

### a. Removal

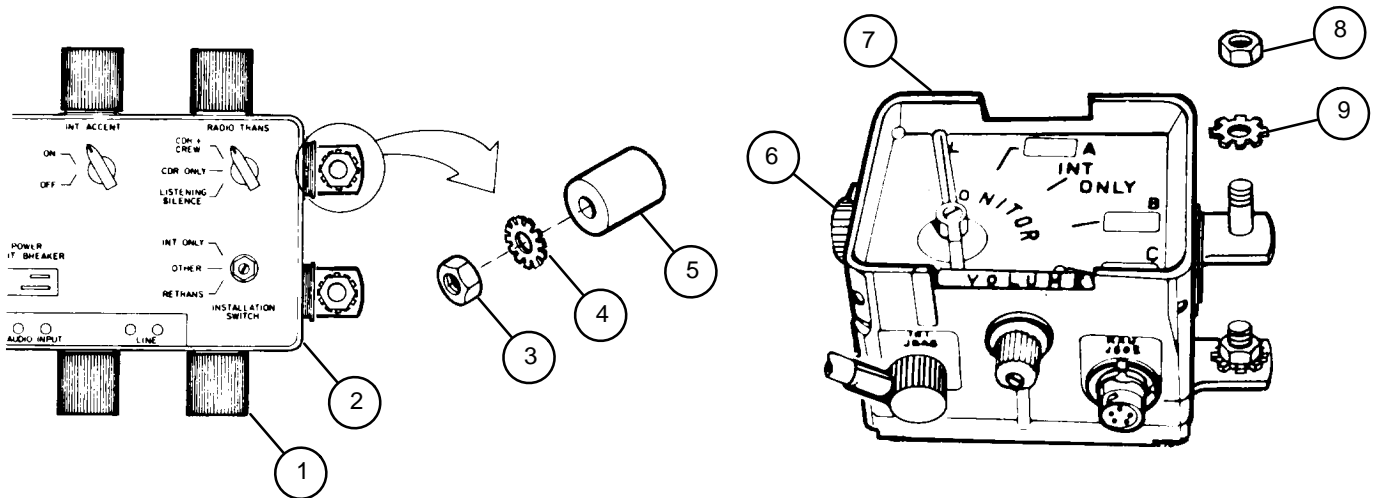
#### NOTE

Check with unit communications personnel before removal or installation of the intercommunications system.

- 1 Disconnect four electrical connectors (1) on amplifier AM1780/VRC (2) at J504, J508, J506, and J505.
- 2 Remove four hex nuts (3), four lockwashers (4), amplifier AM1780/VRC (2), and shock mounts (5). Discard lockwashers.
- 3 Disconnect three electrical connectors (6) from control box (7) at J804, J802, and J803.
- 4 Remove four hex nuts (8) and remove four lockwashers (9) to remove control box (7). Discard lockwashers.

### b. Installation

- 1 Install control box (7) using four new lockwashers (9) and four hex nuts (8).
- 2 Connect three electrical connectors (6) to control box (7) at J804, J802, and J803.
- 3 Install shock mounts (5), amplifier AM1780/VRC (2), four new lockwashers (4) and four hex nuts (3).
- 4 Connect four electrical connectors (1) to amplifier AM1780/VRC (2) at J504, J508, J506, and J505.



## CHAPTER 9

# CAB ELECTRICAL CONTACT BOARD AND CONTACT ARM ASSEMBLIES

---

### GENERAL

This chapter describes and illustrates maintenance procedures for contact board segments and electrical contact arm and holder assembly. Maintenance functions assigned to unit level include replacement, repair, testing, cleaning, and adjustment.

---

<u>CONTENTS</u>	<u>Page</u>
9-1 CONTACT BOARD SEGMENTS FOR 5 CONTACT ARM ASSEMBLIES .....	9-2
9-2 CONTACT BOARD SEGMENTS FOR 3 CONTACT ARM ASSEMBLIES .....	9-5
9-3 ELECTRICAL CONTACT ARM ASSEMBLY .....	9-8

#### NOTE

- Because some howitzers have 3 rather than 5 contact arm assemblies, some variations in maintenance procedures are required. Howitzers with 3 contact arm assemblies have these differences when compared to howitzers with 5 contact arm assemblies:
- 3 contact arm assembly howitzers have 2 ring segments instead of one.
- 3 contact arm assembly howitzers have covers for the ring segments.
- Ring segments on 3 contact arm assembly howitzers have more fasteners than ring segments on 5 contact arm assembly howitzers.





a. Removal

**WARNING**

While performing all procedures in this section except for testing, disconnect the battery ground cable at battery terminal to cut off cab electrical power. Failure to observe this warning could result in severe burns and electrical shock, resulting in injury or death.

**NOTE**

This procedure is written for one contact arm assembly, but applies to all five.

- 1 Remove hex nut (1), lockwasher (2), machine bolt (3), and power cable (4) at bus bar terminal (5). Discard lockwasher.

**NOTE**

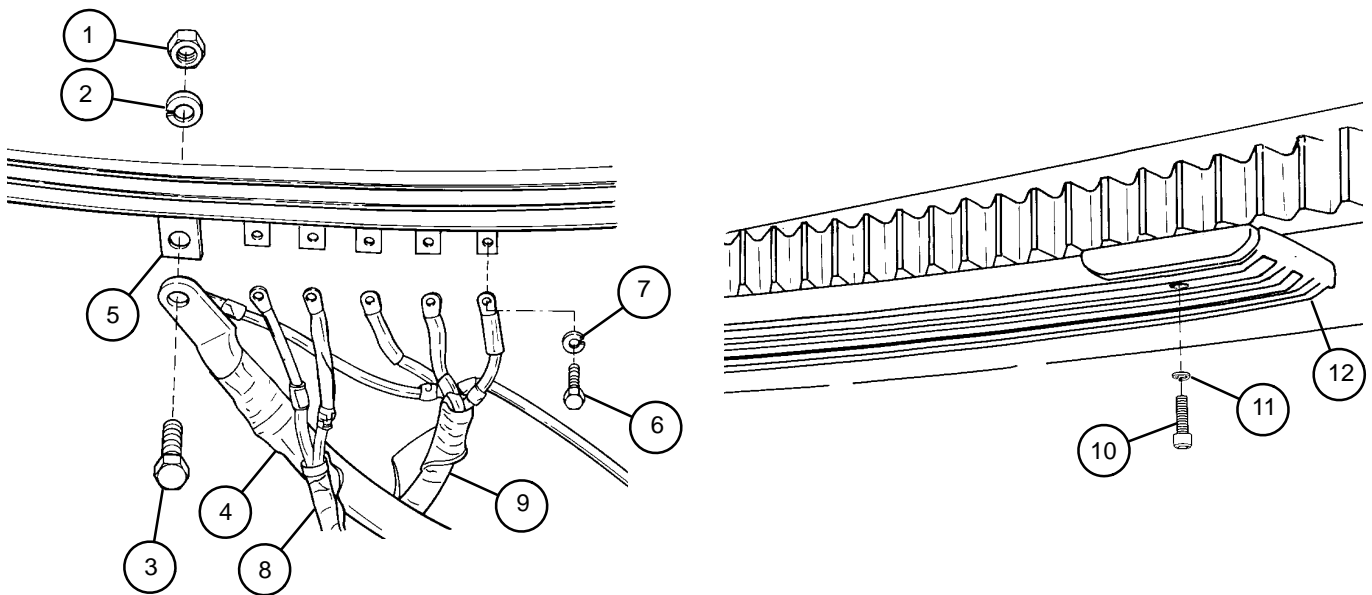
All harnesses must be tagged or marked to assure correct assembly.

- 2 Remove five machine screws (6) and five lockwashers (7) securing harness (8) and telephone intercom harness (9). Lift off harnesses. Discard lockwashers.

**CAUTION**

Use care in removing or installing ring segment. Place ring segment in a safe place to prevent damage to the silver contact surface.

- 3 Remove ten self-locking screws (10) and ten flat washers (11) to release ring segment (12). Discard self-locking screws.



---

## 9-1 CONTACT BOARD SEGMENTS FOR 5 CONTACT ARM ASSEMBLIES — CONTINUED

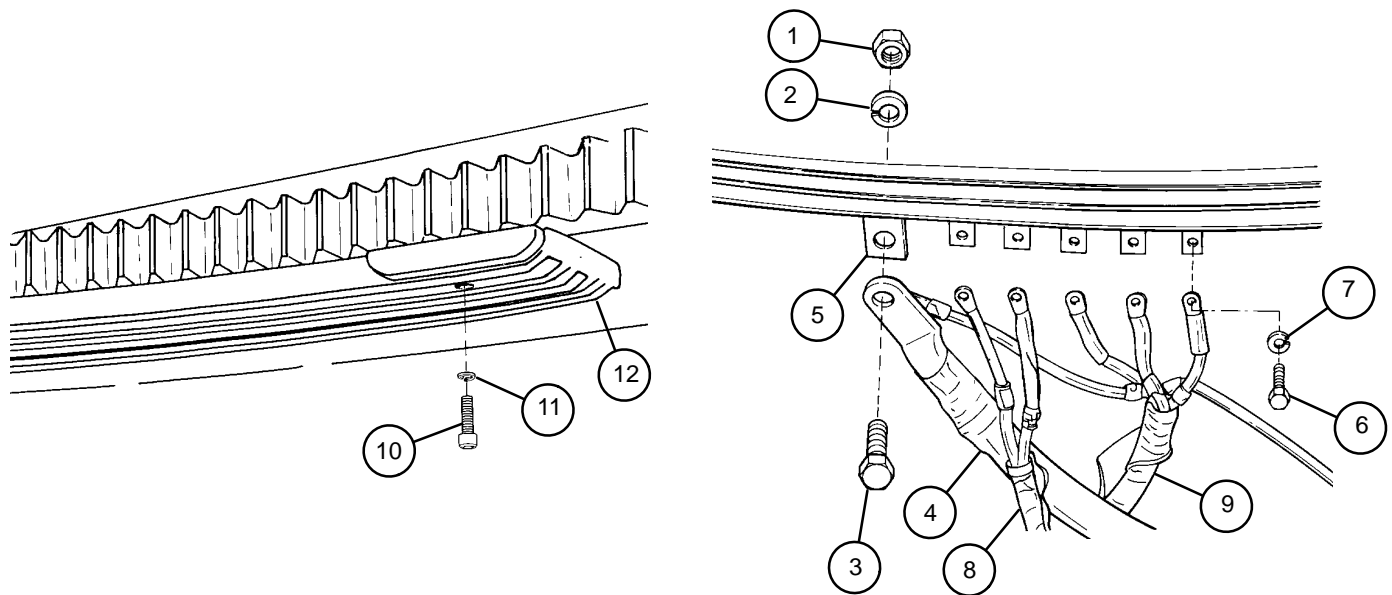
---

### b. Installation

- 1 Aline ten holes on ring segment (12). Install ring segment using ten new self-locking screws (10) and ten flat washers (11).
- 2 Install telephone intercom harness (9) and harness (8) on ring segment (12), using five machine screws (6) and five new lockwashers (7).
- 3 Attach power cable (4) to bus bar terminal (5) with hex nut (1), new lockwasher (2), and machine bolt (3).

### c. Testing

Operate cab electrical system.





**9-2 CONTACT BOARD SEGMENTS FOR 3 CONTACT ARM ASSEMBLIES — CONTINUED**

**a. Removal**

**WARNING**

While performing all procedures in this section except for testing, disconnect the battery ground cable at battery terminal to cut off cab electrical power. Failure to observe this warning could result in severe burns and electrical shock, resulting in injury or death.

**NOTE**

This procedure is written for one contact arm assembly, but applies to all three.

- 1 Remove six cap screws (1), six flat washers (2), and six self-locking nuts (3). This will release ring segment shield (4). Repeat procedure for other ring segment shield. Discard self-locking nuts.
- 2 Remove two machine bolts (5), two lockwashers (6) and two hex nuts (7). This will release power cable (8) at bus bar terminal (9). Discard lockwashers.

**NOTE**

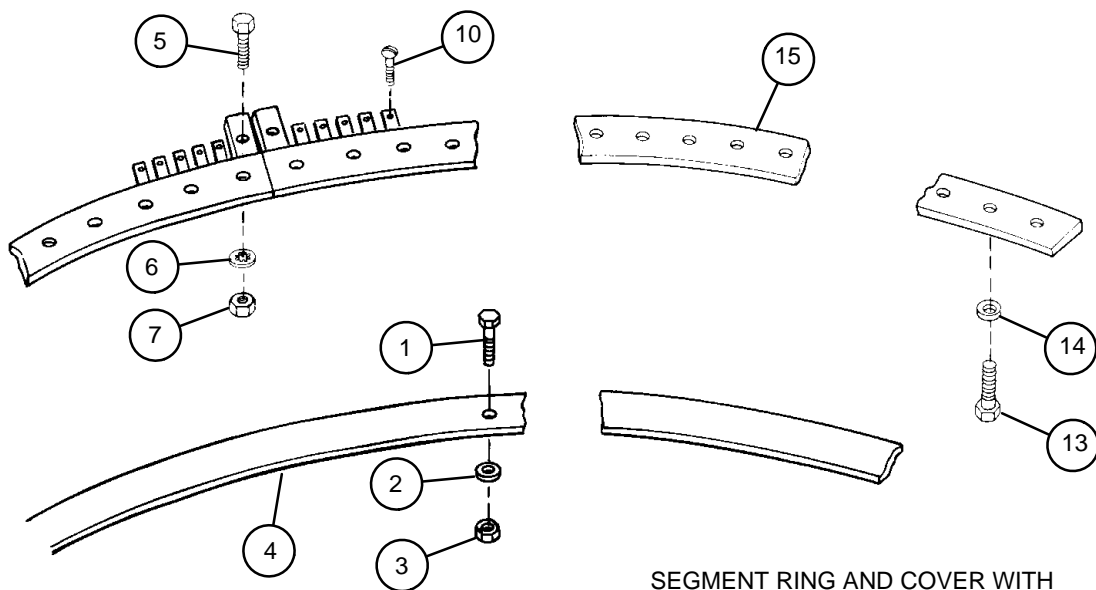
All harnesses must be tagged or marked to assure correct assembly.

- 3 Remove ten machine screws (10) securing harnesses (11 and 12). Lift off harnesses.

**CAUTION**

Use care in removing or installing ring segments. Place ring segments in a safe place to prevent damage to the silver contact surface.

- 4 Remove eight self-locking screws (13) and eight flat washers (14). This will release ring segment (15). Repeat step for other ring segment. Discard self-locking screws.



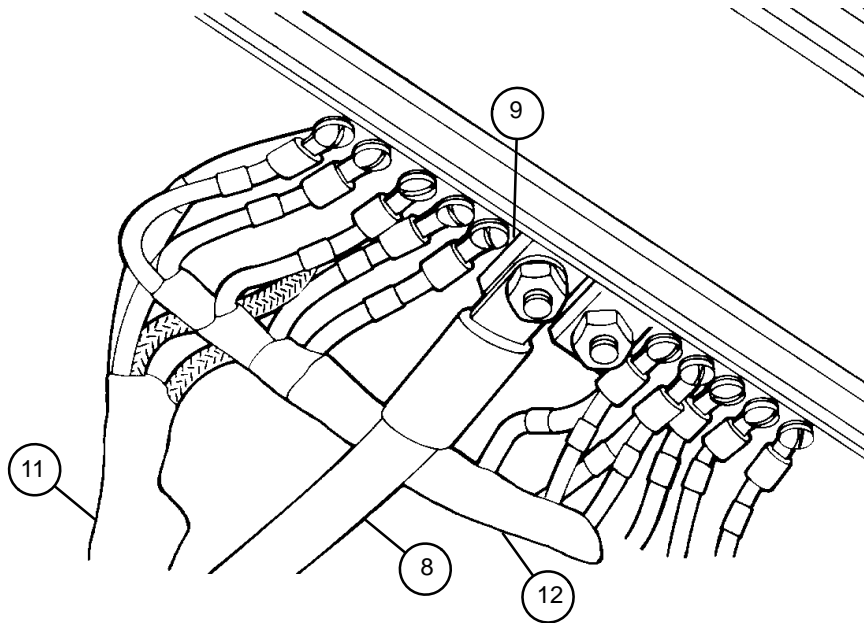
SEGMENT RING AND COVER WITH ATTACHING HARDWARE (DISASSEMBLED)

**b. Installation**

- 1 Install ring segment (15) using eight new self-locking screws (13) and eight flat washers (14). Repeat step for other ring segment.
- 2 Install harnesses (11 and 12) using ten machine screws (10).
- 3 Install power cable (8) on bus bar terminal (9) using two machine bolts (5), two new lockwashers (6), and two hex nuts (7).
- 4 Install ring segment shield (4) using six cap screws (1), six flat washers (2) and six new self-locking nuts (3). Repeat step for other ring segment shield.

**c. Testing**

Operate cab electrical system.



HARNESSES AND POWER CABLE

---

## 9-3 ELECTRICAL CONTACT ARM ASSEMBLY

---

- This task covers:
- |             |                 |
|-------------|-----------------|
| a. Removal  | b. Disassembly  |
| c. Assembly | d. Installation |
| e. Cleaning | f. Adjustment   |
- 

### **INITIAL SETUP**

#### Tools

Artillery and turret mechanic's tool kit  
(SC 5180-95-CL-A12)

Contact brush adjustment gage (Figure E-1, Appx E)

Soldering torch kit (item 13, Appx H)

Soldering gun (item 12, Appx H)

#### Materials/Parts

Cleaning compound (item 9.1, Appx D)

Flux (item 15, Appx D)

Lockwashers (5) (item 55, Appx G)

Lockwashers (4) (item 56, Appx G)

Lockwashers (6) (item 64, Appx G)

Lockwashers (2) (item 79, Appx G)

Rosin core solder (item 34, Appx D)

Sealing compound (item 30, Appx D)

Shims (V) (item 111, Appx G)

#### Equipment Condition

Disconnect batteries (TM 9-2350-311-20-1)

---

### **a. Removal**

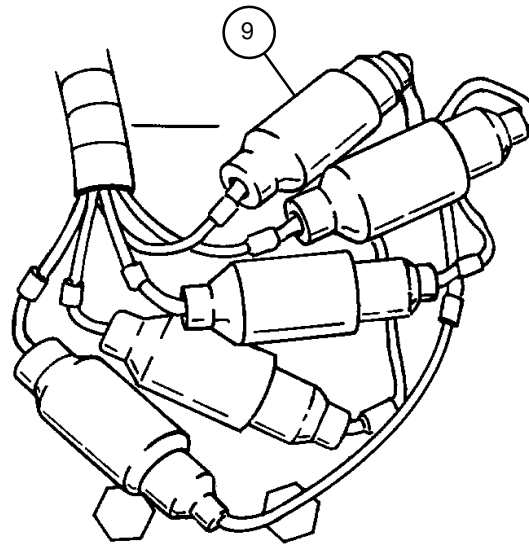
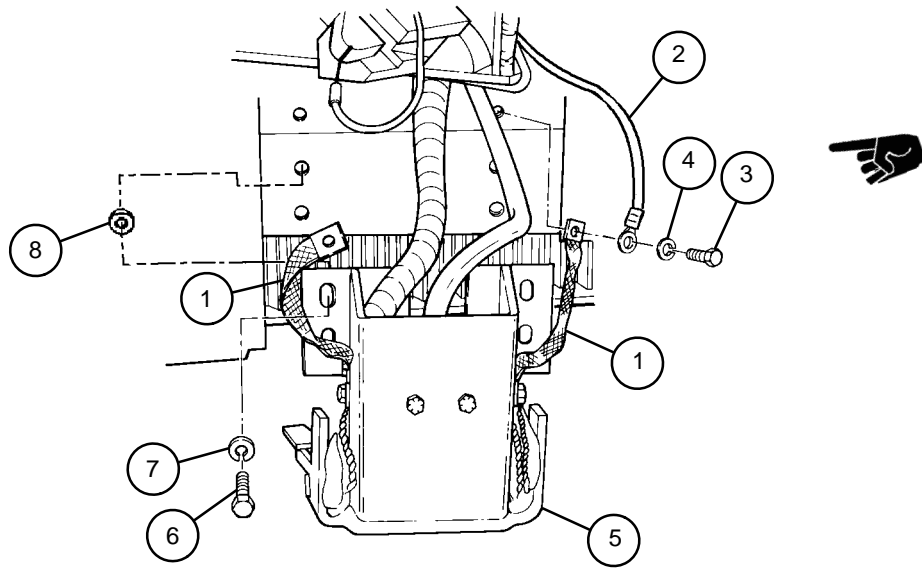
**WARNING**

While performing all procedures in this section except for adjustment, disconnect the battery ground cable at battery terminal to cut off cab electrical power. Failure to observe this warning could result in severe burns and electrical shock, resulting in injury or death.

#### **NOTE**

Perform these procedures for each of 3 or 5 electrical contact arm assemblies.

- 1 Disconnect ground straps (1) and ground wire (2) by removing one cap screw (3) and lockwasher (4) from each side of the electrical contact arm (5). Discard lockwasher.
- 2 Remove electrical contact arm (5) by removing four cap screws (6), four lockwashers (7), and shims (8). Discard lockwashers and shims.
- 3 Disconnect five electrical leads at quick disconnects (9).



## 9-3 ELECTRICAL CONTACT ARM ASSEMBLY — CONTINUED

### a. Removal — Continued

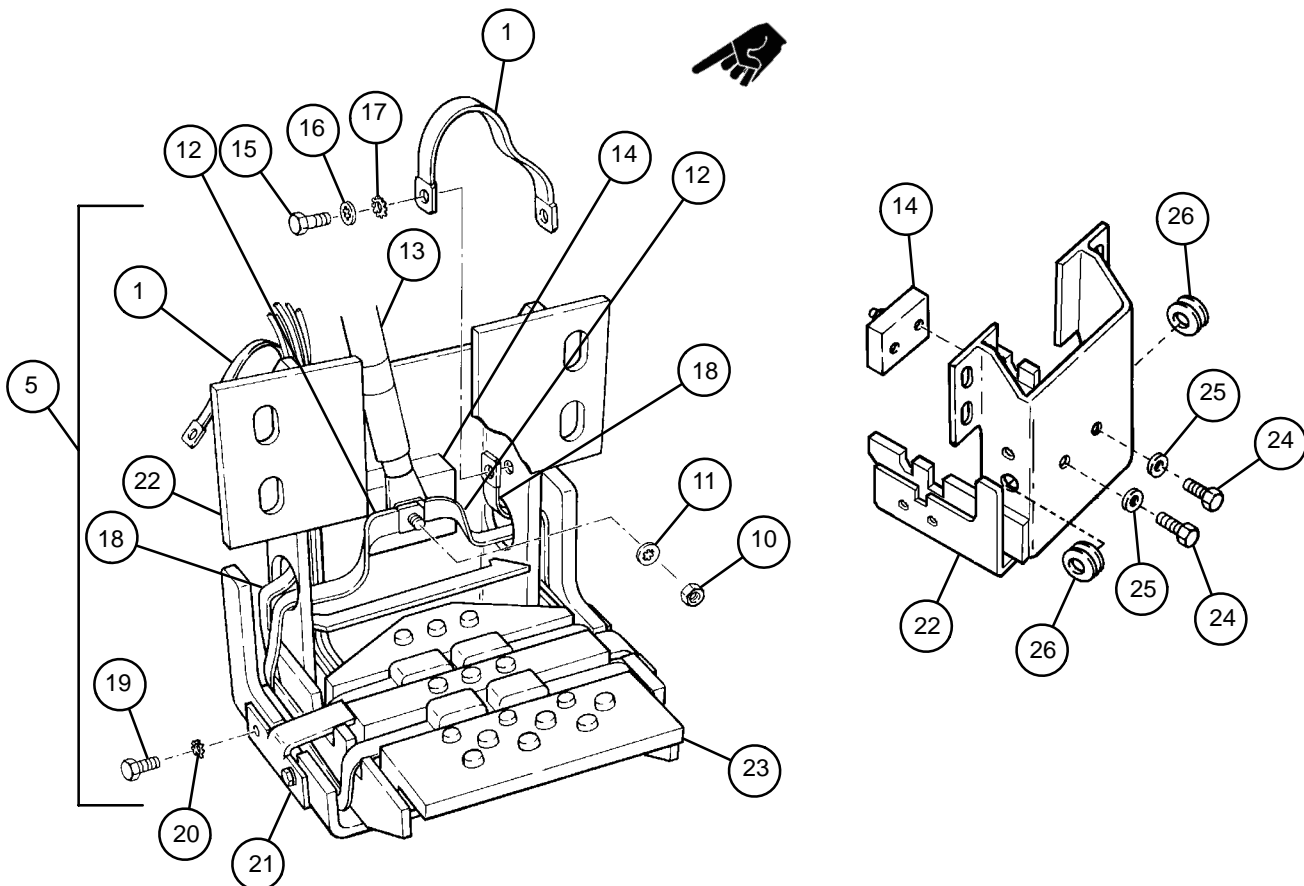
- 4 Remove hex nut (10) and lockwasher (11) securing two electrical contact brush leads (12) and wire 100 (13) to terminal board (14). Discard lockwasher.

### b. Disassembly

#### NOTE

Ground straps may not be on all electrical contact arms.

- 1 Remove two cap screws (15), two lockwashers (16), and two lockwashers (17) from electrical contact arm (5) to remove both ground straps (1) and two ground electrical contact brush leads (18). Discard lockwashers.
- 2 Remove four cap screws (19) and four lockwashers (20) and two angle brackets (21) from mechanical drive guard (22). Discard lockwashers.
- 3 Remove electrical holder assembly (23) from mechanical drive guard (22).
- 4 Remove two cap screws (24) and two lockwashers (25) securing terminal board (14) to mechanical drive guard (22). Discard lockwashers.
- 5 Remove two non-metallic grommets (26) from mechanical drive guard (22).





- 6 Remove four machine screws (27) securing two electrical contact brushes (12) and two ground electrical contact brushes (18).
- 7 Remove two electrical contact brushes (12), two ground electrical contact brushes (18), and eight springs (28) from electrical contact holder (29).
- 8 Remove six machine screws (30), four machine screws (31), and five electrical contact brushes (32) with attached leads (33) from electrical contact holder (29).

**NOTE**

Perform step 9 only if wires are broken or defective.

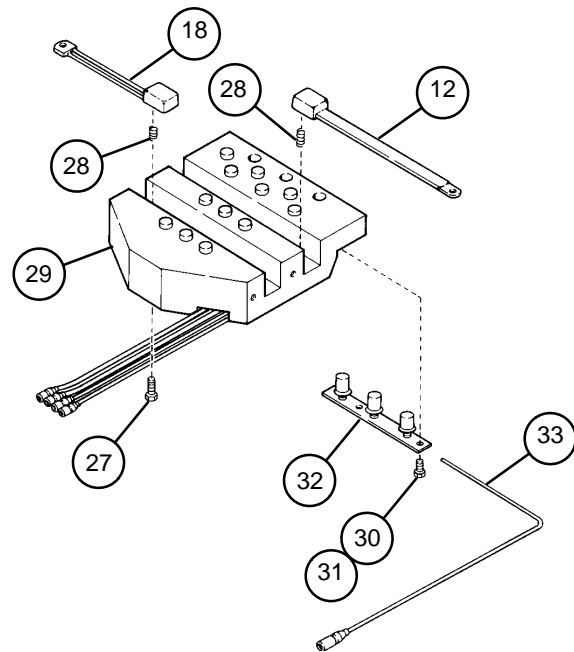
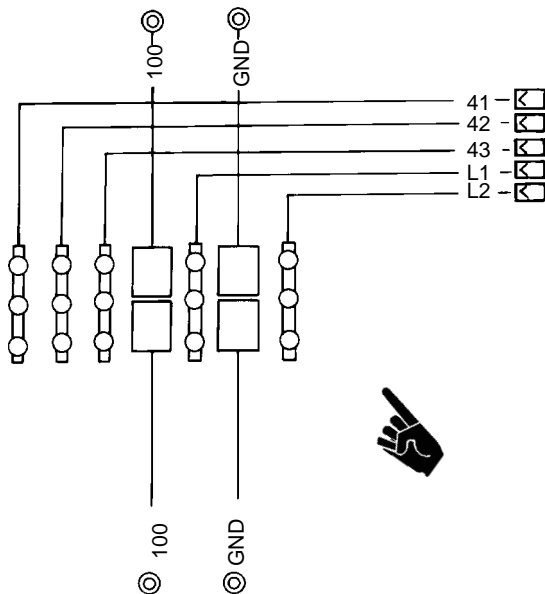
- 9 Unsolder electrical lead (33) from electrical contact brush (32).

**c. Assembly**

**NOTE**

- When reassembling electrical contact brushes (12 and 18), adjust to same height as contacts.
- Apply one drop of sealing compound to thread of screws.
- Use rosin core solder only. For soldering instructions, refer to para 2-16.
- Use wiring schematic as a guide for installation of electrical leads.

- 1 If electrical lead (33) has been unsoldered for replacement, solder new electrical lead to electrical contact brush (32).
- 2 Install four machine screws (31) and six machine screws (30) on five electrical brushes (32) with attached leads (33), aligning wires in grooves to electrical contact holder (29).
- 3 Install four springs (28) and two electrical contact brushes (12) with two machine screws (27) into electrical contact holder (29).
- 4 Install four springs (28) and two ground electrical contact brushes (18) with two machine screws (27) into electrical contact holder (29).



## 9-3 ELECTRICAL CONTACT ARM ASSEMBLY — CONTINUED

### c. Assembly — Continued

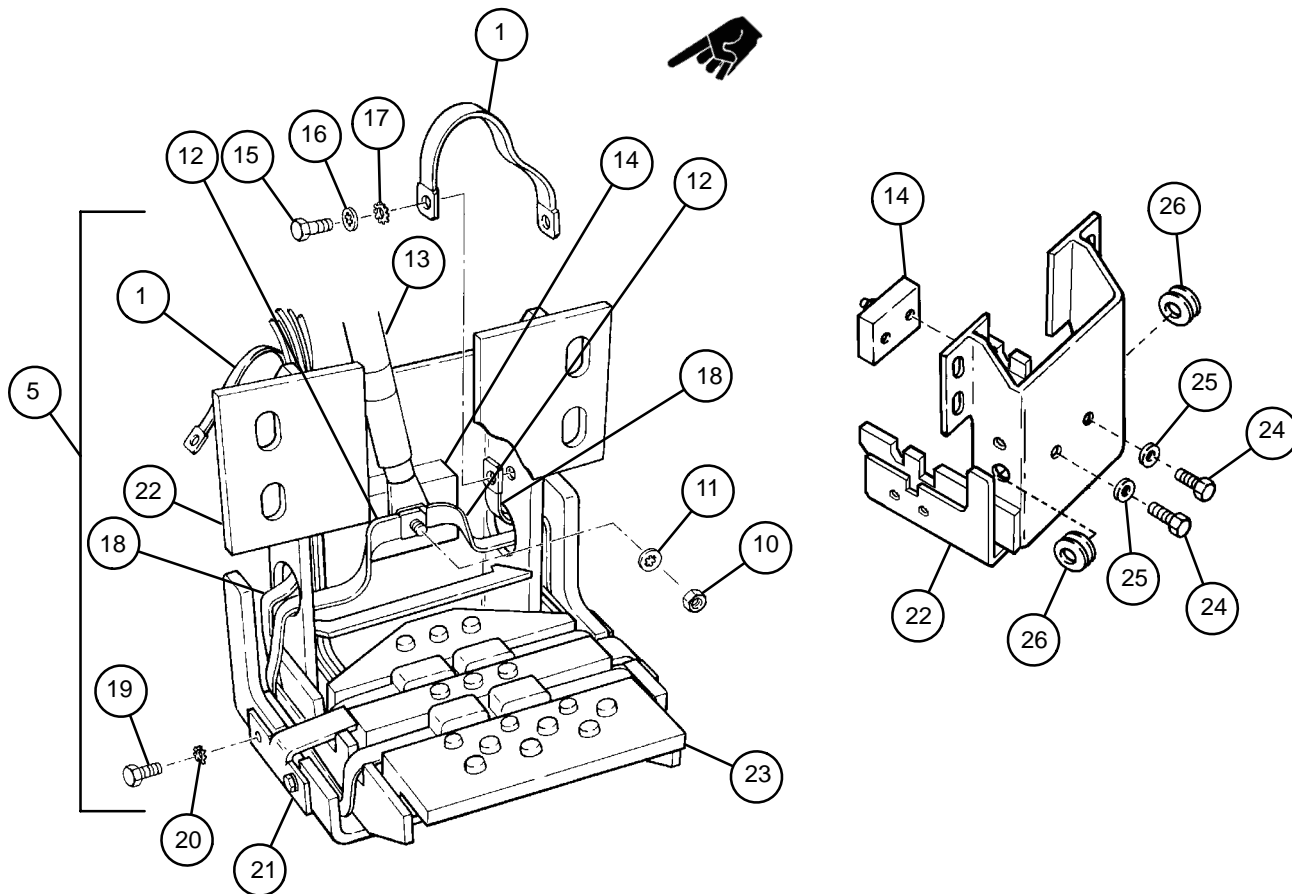
- 5 Install two non-metallic grommets (26) on mechanical drive guard (22). Install terminal board (14) on mechanical drive guard (22) using two cap screws (24) and two new lockwashers (25).
- 6 Install electrical holder assembly (23) in mechanical drive guard (22). Insert two electrical contact brush leads (12) and two ground electrical contact brush leads (18) through non-metallic grommets (26) and secure two angle brackets (21) with four cap screws (19) and four new lockwashers (20).
- 7 Attach two ground straps (1) (if present) and two ground electrical contact brush leads (18) to mechanical drive guard (22) using two cap screws (15), two new lockwashers (16), and two new lockwashers (17).

### d. Installation

#### NOTE

Adjust electrical contact arms after installation (para 9-3f.).

- 1 Attach two electrical contact brush leads (12) and wire 100 (13) to terminal board (14) using new lockwasher (11) and hex nut (10).

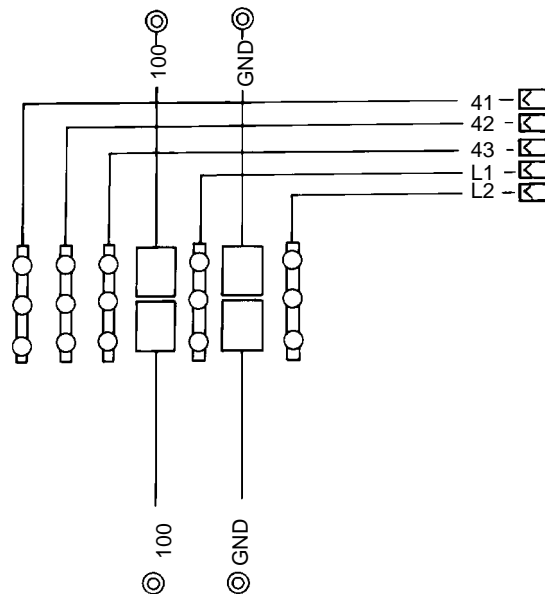
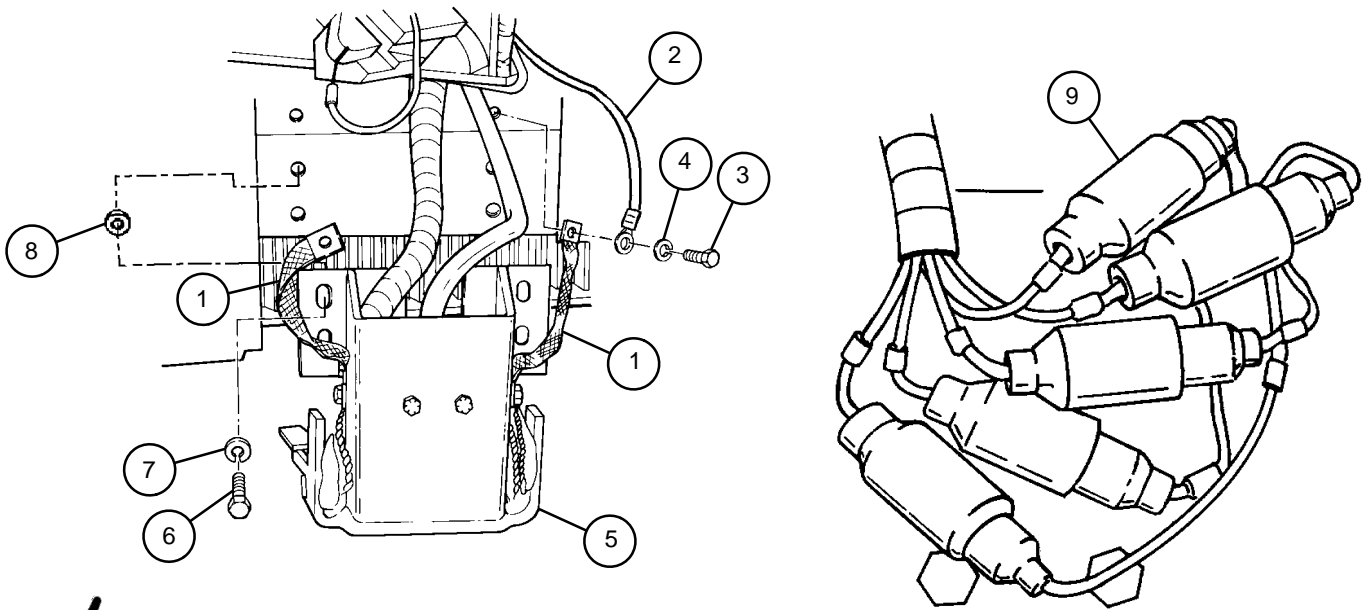


- 2 Connect five electrical leads at quick disconnects (9).

**NOTE**

Do not tighten cap screws until adjustment is completed.

- 3 Install electrical contact arm (5) on hull using four cap screws (6) and four new lockwashers (7). New shims (8) should be used as necessary to secure correct clearance (para 9-3f.).
- 4 Using two cap screws (3) and two new lockwashers (4), attach free end of two ground straps (1) and ground wire (2) from harness to hull.
- 5 Adjust electrical contact arms (5) to segment board (para 9-3f.).



---

**9-3 ELECTRICAL CONTACT ARM ASSEMBLY — CONTINUED**

---

**e. Cleaning****WARNING**

Make sure battery ground cables are disconnected at battery terminals before beginning this procedure. Failure to observe this warning could result in severe burns and electrical shock, resulting in injury or death.

- 1 Manually traverse cab until the electrical contact arm (5) to be cleaned and adjusted is located at the rear of the vehicle. Traversing electrical contact arm to the rear will make sure that brushes (34) are clear of ring segment (35) and make electrical contact arm more accessible.
- 2 Remove two cap screws (3) and two lockwashers (4) to release ground straps (1) and ground wire (2) of harness from hull. Remove four cap screws (6), four lockwashers (7), and shims (8). Electrical contact arm (5) will now come off. Discard lockwashers and shims.

**WARNING**

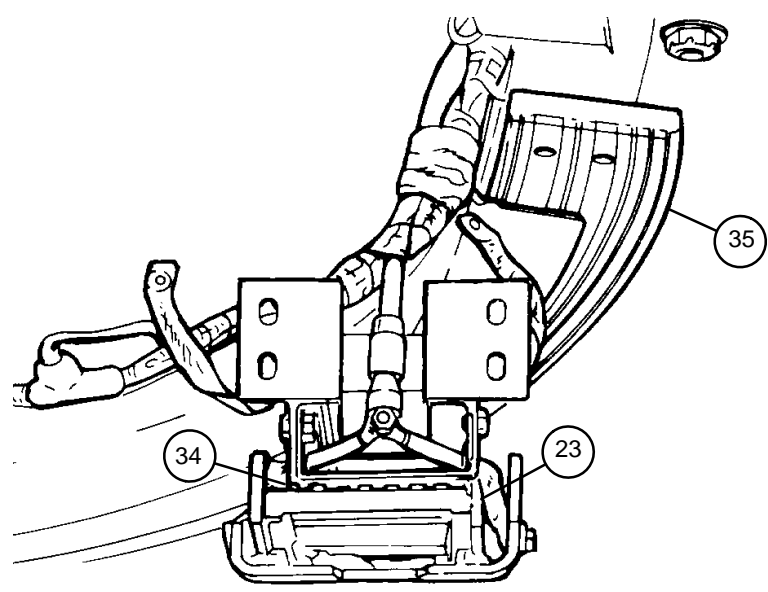
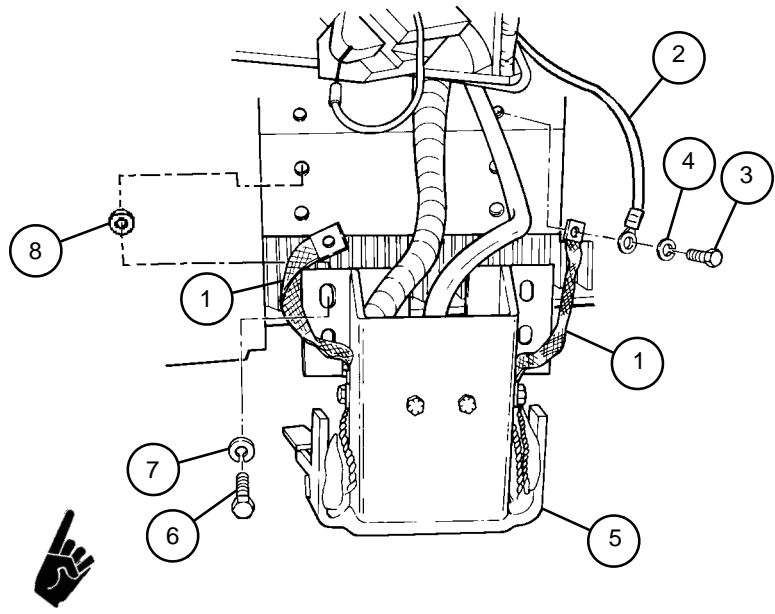
Solvents can burn easily, can give off harmful vapors, and are harmful to skin and clothing. To avoid injury or death, keep away from open fire and use in well-ventilated area. If solvent gets on skin or clothing, wash immediately with soap and water.

- 3 Use cleaning compound to clean brushes (34), electrical holder assembly (23), and ring segment (35). Allow cleaning compound to dry.

**NOTE**

Do not tighten four cap screws in step 4 until adjustment.

- 4 Install electrical contact arm (5) using four cap screws (6), four new lockwashers (7), and new shims (8). Install ground straps (1) and ground wire (2) of harness to hull using two cap screws (3) and two new lockwashers (4).



---

**9–3 ELECTRICAL CONTACT ARM ASSEMBLY — CONTINUED**

---

**f. Adjustment**

- 1 Ensure MASTER switch (36) is OFF.
- 2 Manually traverse cab until electrical contact arm (5) is under ring segment (35).
- 3 Set the feeler gage to measure a thickness of 0.105 inch (2.67 mm). Place feeler gage between rails of ring segment (35) and surface of electrical holder assembly (23) closest to mounting bracket. Make sure that clearance between the surface of the electrical holder assembly and the surface of the ring segment is  $0.105 \pm 0.002$  inch ( $2.67 \pm 0.05$  mm). To adjust the clearance between the two surfaces, vertically lift the electrical contact arm (5). Measurement must be taken on both sides of the rear surface of the electrical holder assembly.
- 4 Measure for proper clearance on the forward side of the electrical holder assembly (23). If forward side of electrical holder assembly is less than  $0.105 \pm 0.002$  inch ( $2.67 \pm 0.05$  mm), add shims (8) to bottom mounting cap screws (6). If forward side is greater than  $0.105 \pm 0.002$  inch ( $2.67 \pm 0.05$  mm), add shims (8) to top mounting cap screws (6). When proper clearance is achieved, tighten the four cap screws.
- 5 Ensure horizontal alinement of electrical contact arm (5) and rails of ring segment (35) by loosening cap screws (19) on angle bracket (21) and sliding assembly forward or backward to obtain and maintain alinement throughout procedure.
- 6 Once correct clearance and alinement is obtained, torque all cap screws to specifications listed in Table F–1. Reverify all clearances and alinements.
- 7 Repeat this procedure for remaining electrical contact arms.

**NOTE**

- Illustrations show slip ring covers removed for clarity.
- The electrical contact brushes of electrical contact arms can be adjusted quickly and easily by using locally made adjustment gages. Gages can be made from fiberboard. Gage material should be  $0.105 \pm 0.002$  inch ( $2.67 \pm 0.05$  mm) thick. Closest fractional dimension for thickness is  $7/64$  inch (2.78 mm).







# CHAPTER 10 CAB WEATHER COVER

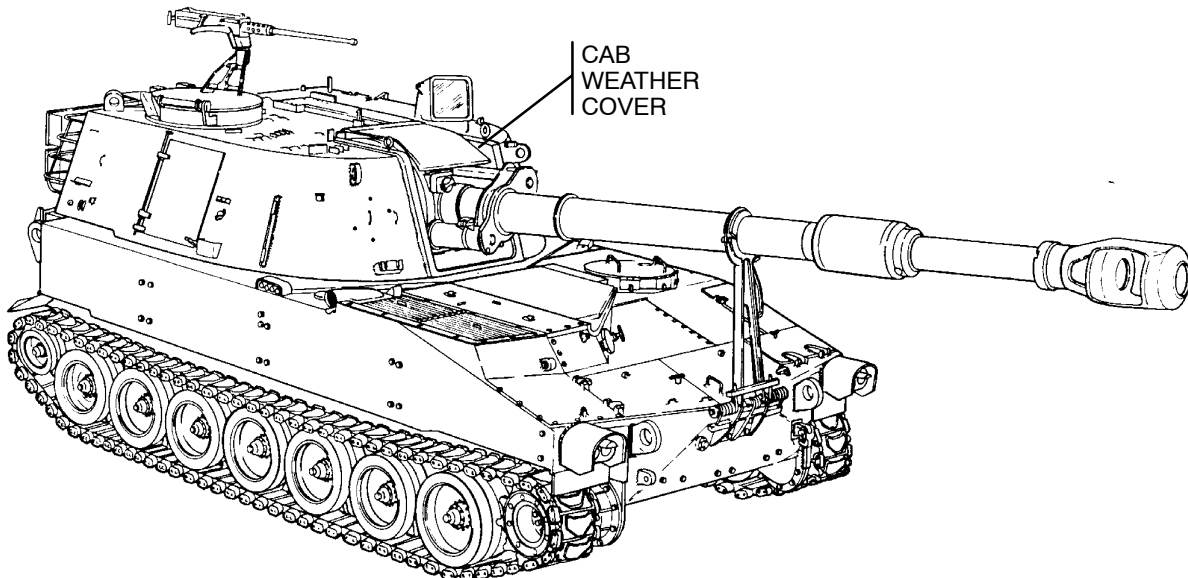
---

## GENERAL

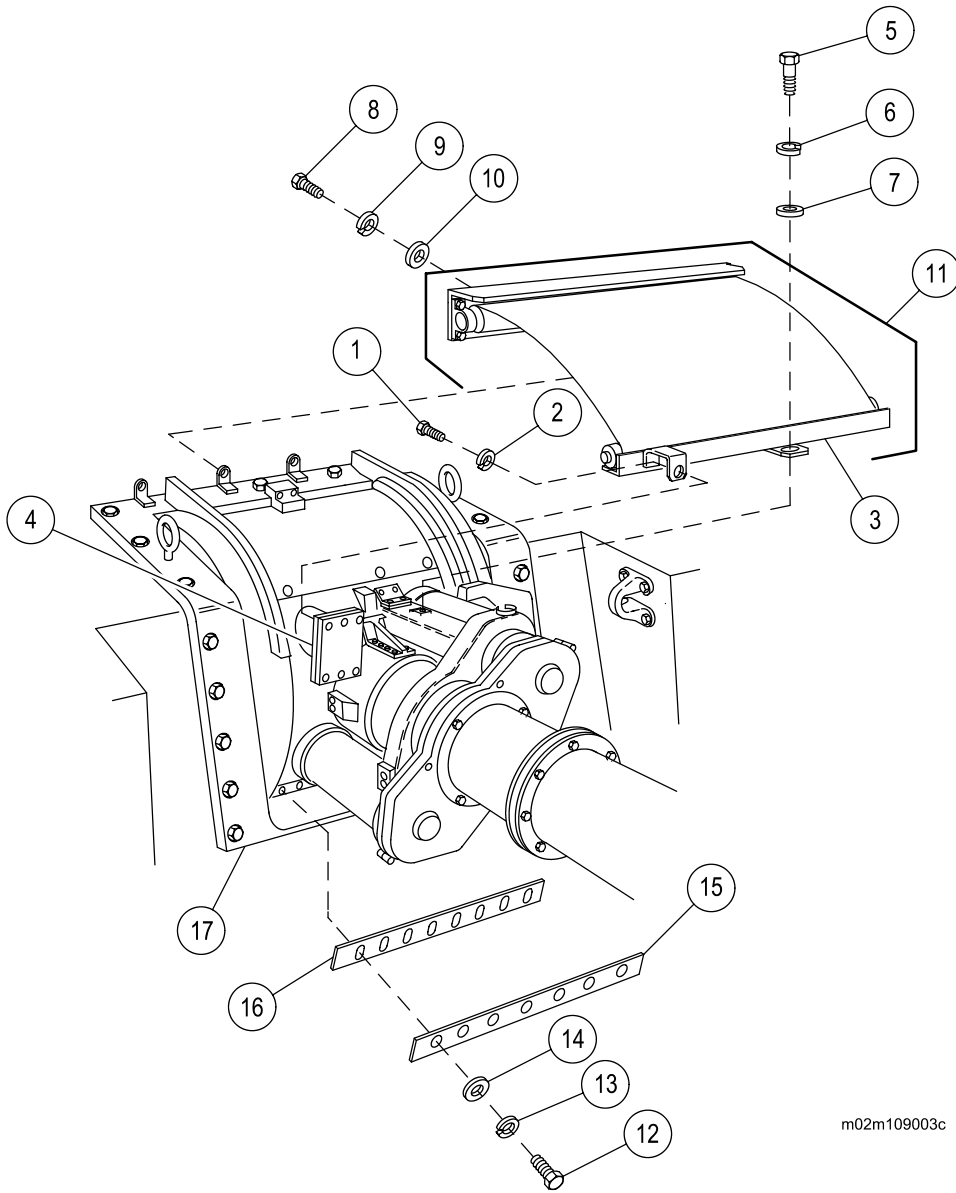
This chapter describes and illustrates removal and installation procedures for the cab weather cover.

---

<u>CONTENTS</u>	<u>Page</u>
CAB WEATHER COVER .....	10-2







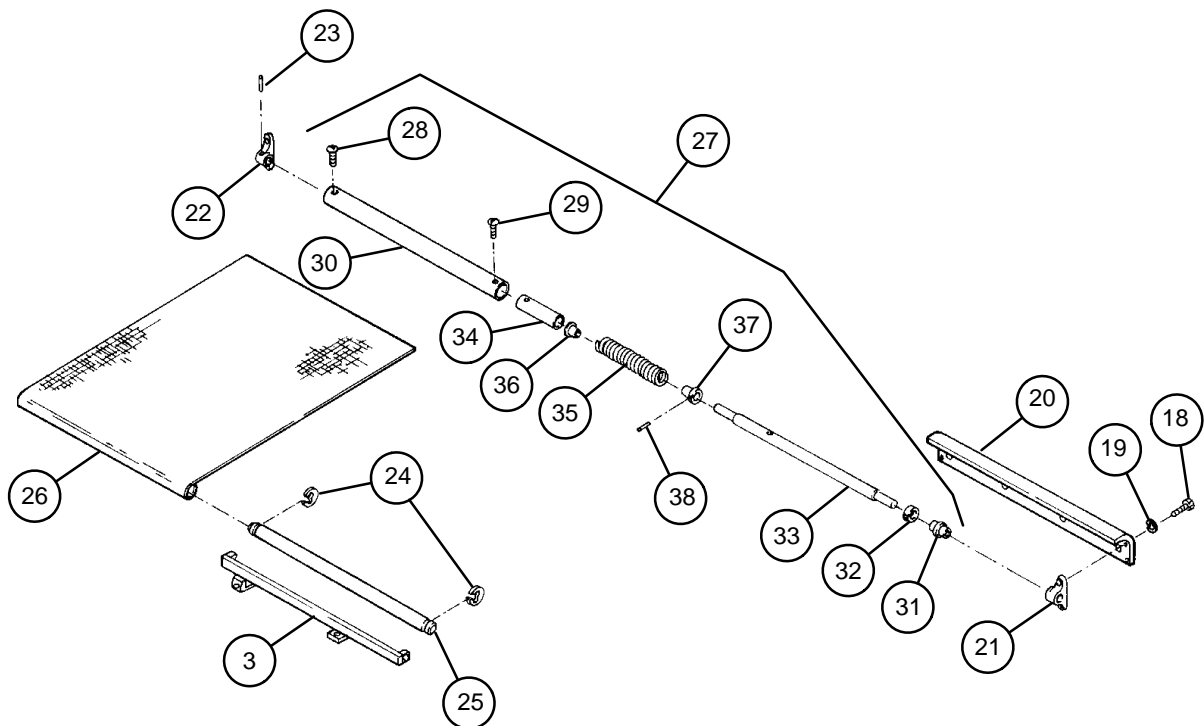
m02m109003c

NOTE: Pages 10-4 through 10-6 deleted.



**d. Assembly**

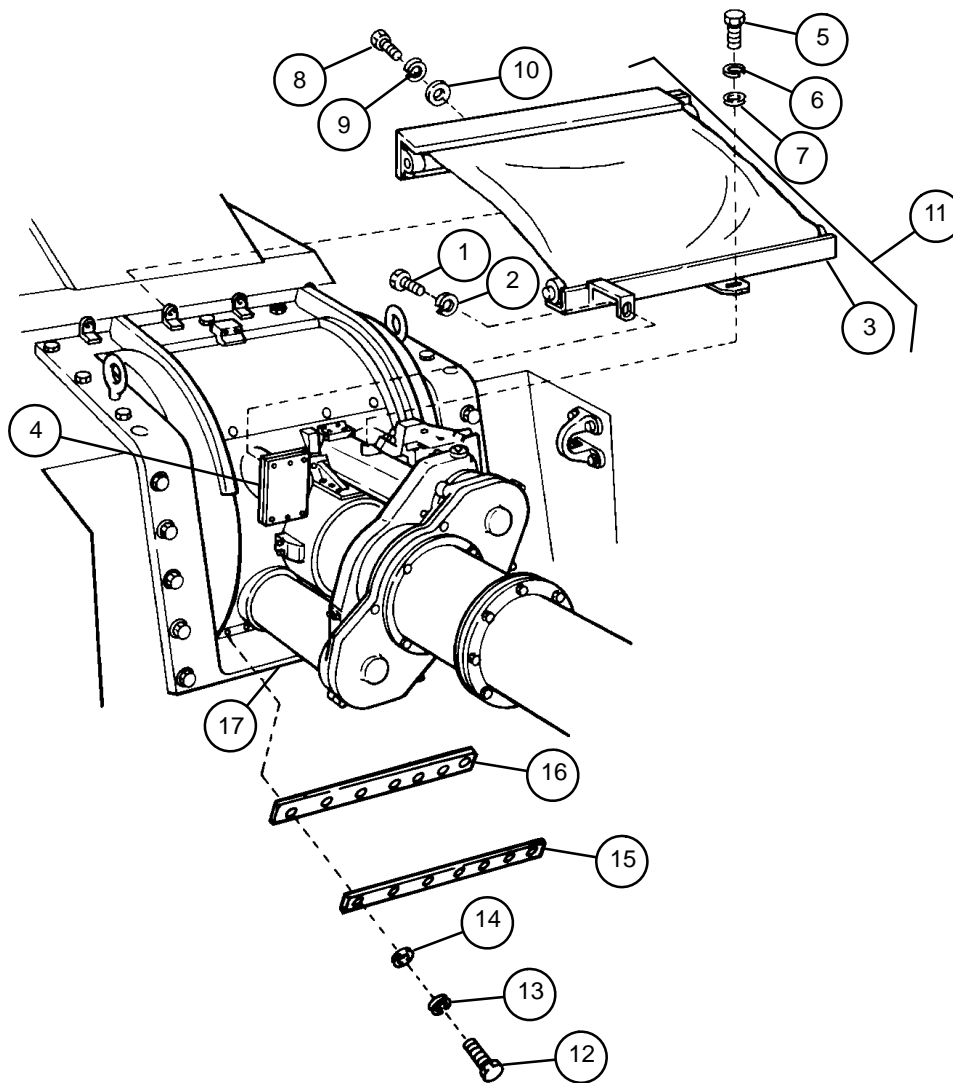
- 1 To assemble roller group (27), install collar (32) and sleeve bearing (31) to shaft (33).
- 2 Install spring anchor (37) on shaft (33) and align holes; secure with new spring pin (38). Lubricate spring pin with CLP.
- 3 Slide helical spring (35) and spring anchor (36) on shaft (33). Attach helical spring to spring anchors (36 and 37). Lubricate helical spring with CLP.
- 4 Install sleeve bushing (34) on end of shaft (33).
- 5 Install tube (30) on shaft (33) and align holes in tube with holes in spring anchor (36) and collar (32); secure with machine screws (28 and 29).
- 6 Install shaft (25) into curtain assembly (26) and mounting bracket (3).
- 7 Install two retaining rings (24) onto shaft (25). Roll curtain up.
- 8 Install mounting bracket (21) using two new lockwashers (19) and two cap screws (18).
- 9 Position mounting bracket (22) on end of shaft (33) aligning it with hole in sleeve bushing (34); secure with new spring pin (23).
- 10 Wind mounting bracket (22) four turns counterclockwise and mount to mounting bracket (20) using two new lockwashers (19) and two cap screws (18).



## CAB WEATHER COVER — CONTINUED

### e. Installation

- 1 Install non-metallic seal (16), backing strip (15), seven flat washers (14), seven new lockwashers (13), and seven cap screws (12) onto trunnion mounting bracket (17).
- 2 Install curtain roller assembly (11) to trunnion mounting bracket using four flat washers (10), four new lockwashers (9), and four machine bolts (8).
- 3 Extend curtain assembly (26) and secure mounting bracket (3) with flat washer (7), new lockwasher (6), and machine bolt (5).
- 4 Install new lockwasher (2) and cap screw (1) to secure mounting bracket (3) to mount (4).



## CHAPTER 11 TURRET LOCK AND TRAVERSING MECHANISM ASSEMBLIES

### GENERAL

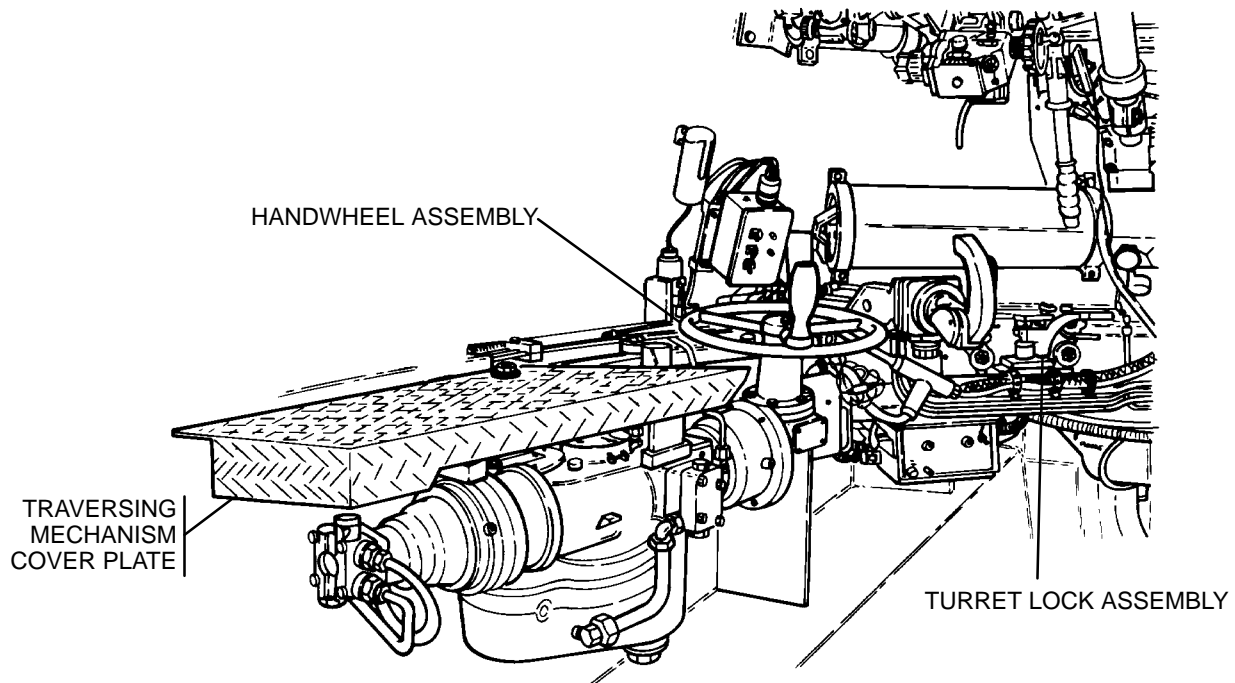
This chapter illustrates and describes the removal, disassembly, assembly, and installation of the turret lock assembly; and the removal and installation of the traversing mechanism cover plate and electrical contact assembly.

#### NOTE

Refer to paragraph 2-9 and TM 9-2350-311-10 to service traversing mechanism.

### CONTENTS

	<u>Page</u>
11-1 TURRET LOCK ASSEMBLY .....	11-2
11-2 TRAVERSING MECHANISM COVER PLATE .....	11-9
11-3 ELECTRICAL CONTACT ASSEMBLY .....	11-10.1
11-4 HANDWHEEL ASSEMBLY .....	11-11

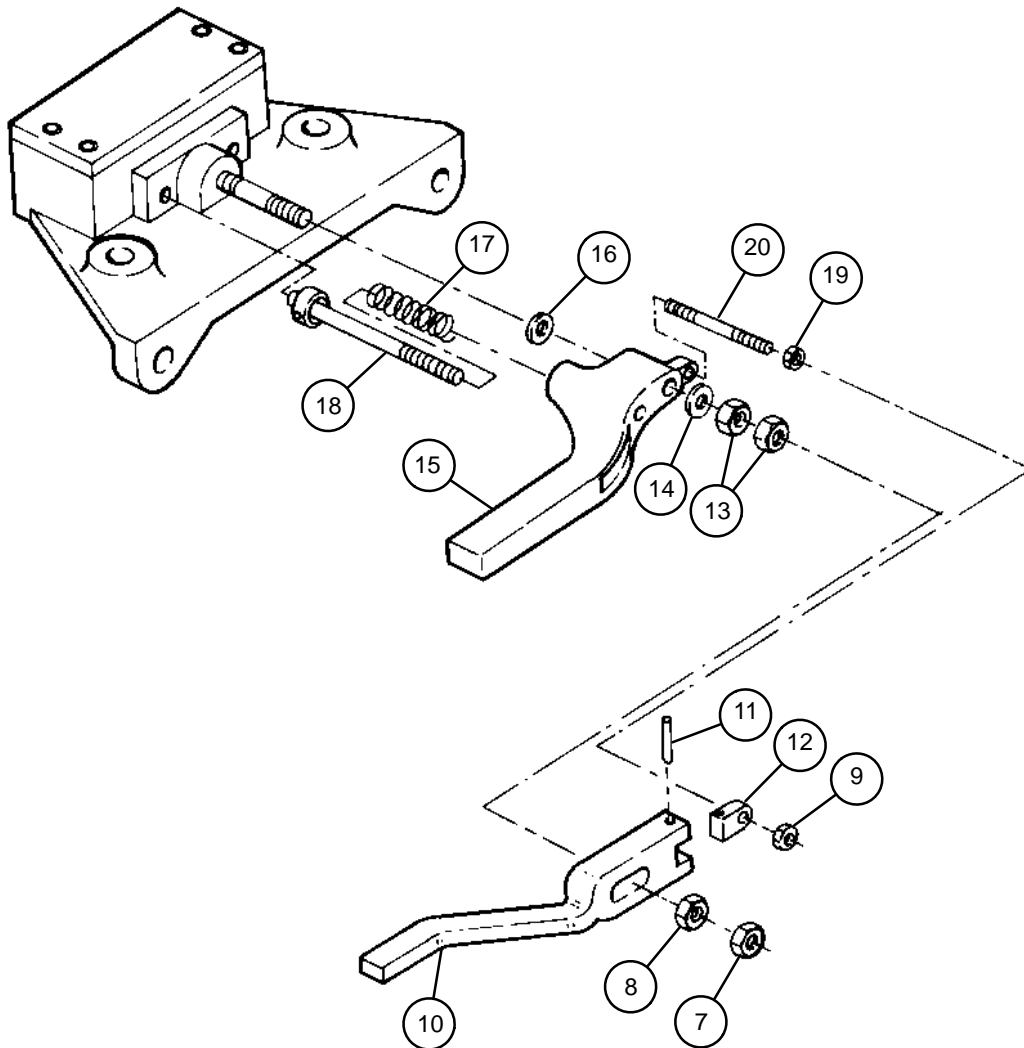






**b. Disassembly**

- 1 Remove nuts (7, 8, and 9).
- 2 Remove manual control lever (10) with attached parts.
- 3 Drive out spring pin (11) and remove turret lock arm (12) from manual control lever (10). Discard spring pin.
- 4 Remove two hex nuts (13), flat washer (14), manual control lever (15), flat washer (16), helical compression spring (17), and pin assembly (18).
- 5 Remove hex nut (19) and stud (20) from manual control lever (15).



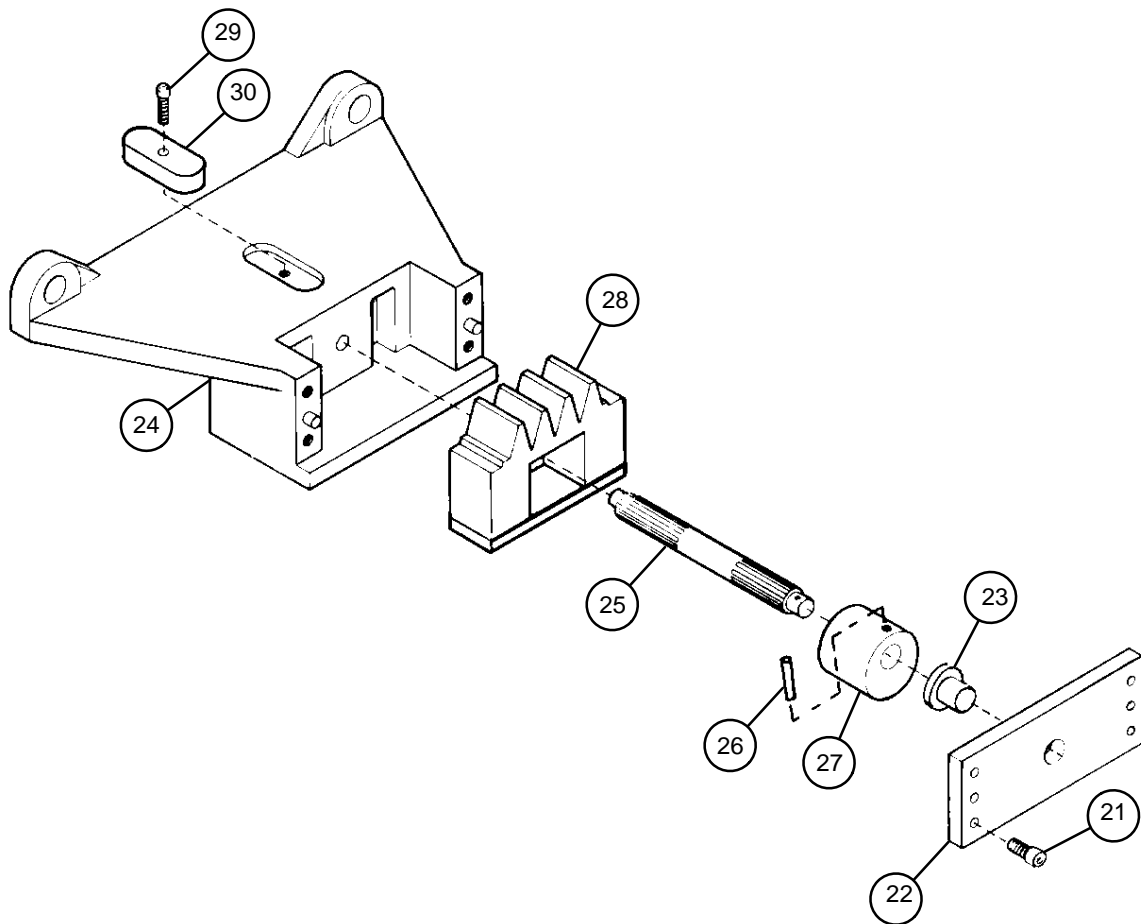
---

## 11-1 TURRET LOCK ASSEMBLY — CONTINUED

---

### b. Disassembly — Continued

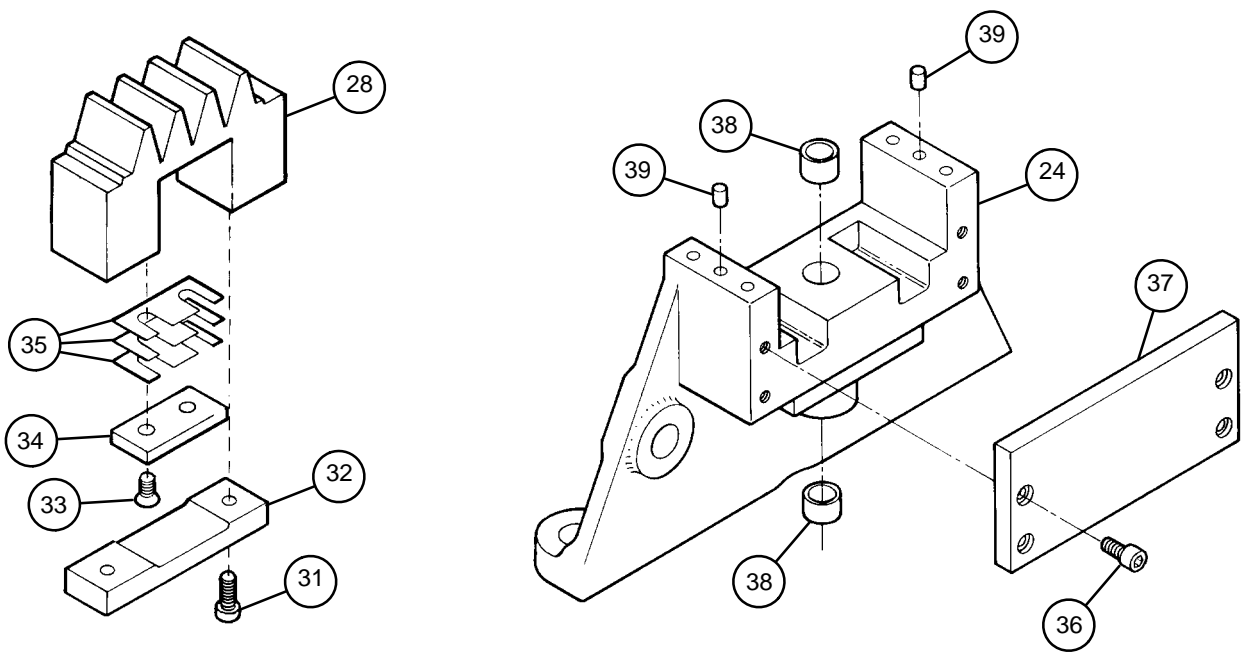
- 6 Remove four cap screws (21), plate (22), and bearing (23) from bracket (24).
- 7 Remove shaft (25) with attached parts.
- 8 Drive out spring pin (26) and remove cam (27) from shaft (25). Discard spring pin.
- 9 Remove gear (28) with attached parts, cap screw (29), and machine key (30).



- 10 Remove two cap screws (31), access cover (32), two machine screws (33), retainer (34), and shims (35) (if any) from gear (28). Tie shims together and retain for reassembly.
- 11 Remove four cap screws (36) and access cover (37).
- 12 Press out two sleeve bearings (38) from bracket (24). Remove two straight pins (39).

**c. Assembly**

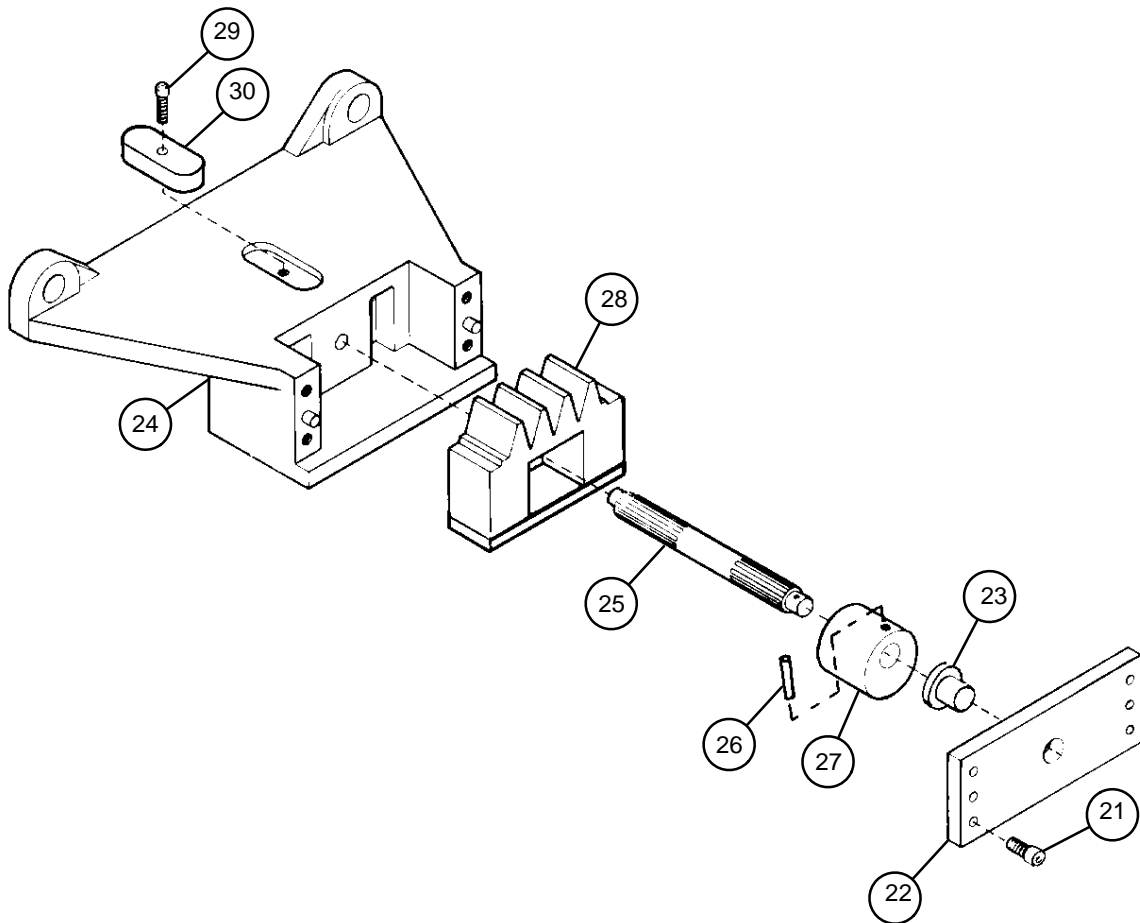
- 1 Press in two sleeve bearings (38) and place two straight pins (39) in bracket (24).
- 2 Install access cover (37) and four socket head cap screws (36).
- 3 Install original shims (35) (if removed), retainer (34), two machine screws (33), access cover (32), and two socket head cap screws (31) on gear (28).



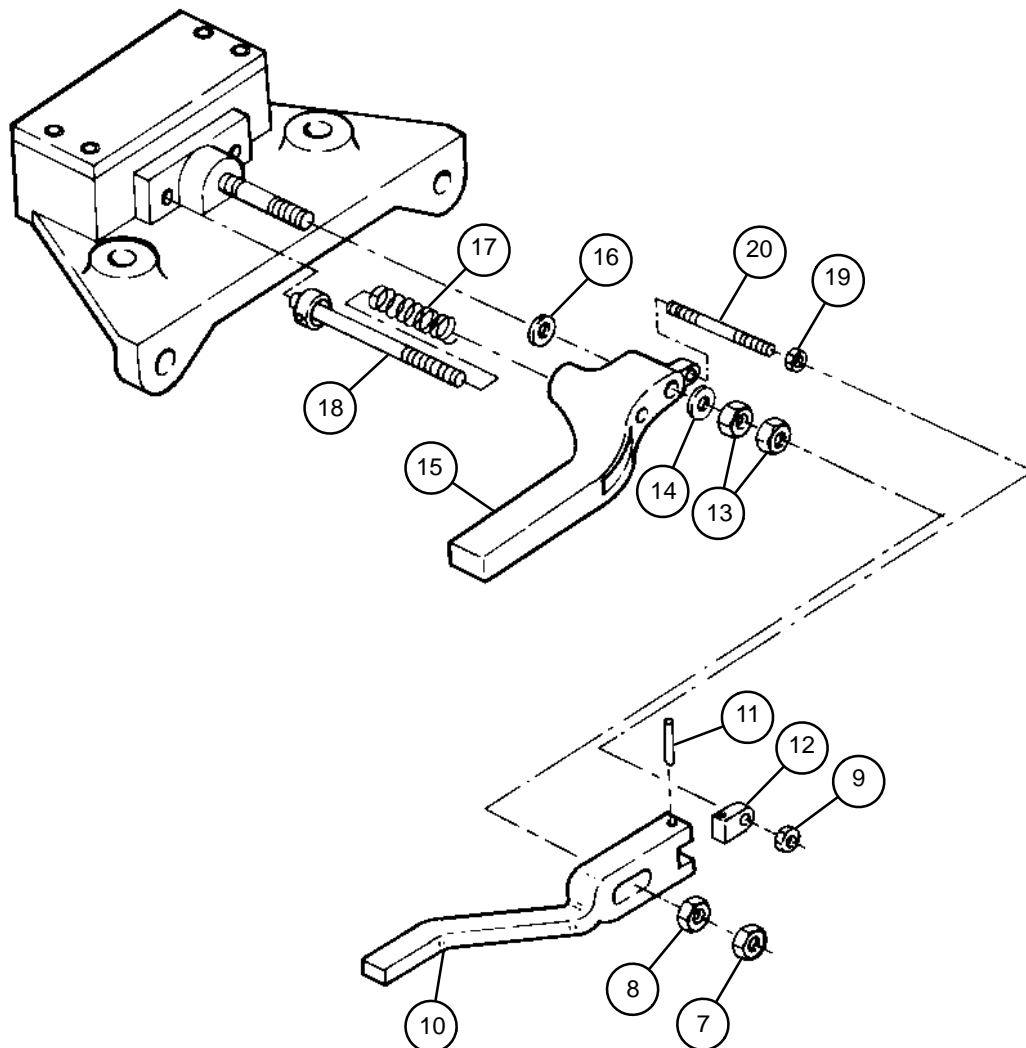
## 11-1 TURRET LOCK ASSEMBLY — CONTINUED

### c. Assembly — Continued

- 4 Place gear (28) with attached parts in bracket (24).
- 5 Install machine key (30) and cap screw (29).
- 6 Install cam (27) on shaft (25), aline holes and secure with new spring pin (26).
- 7 Slide end of shaft (25) through gear (28) into hole in bracket (24). Install bearing (23), plate (22), and four head cap screws (21).



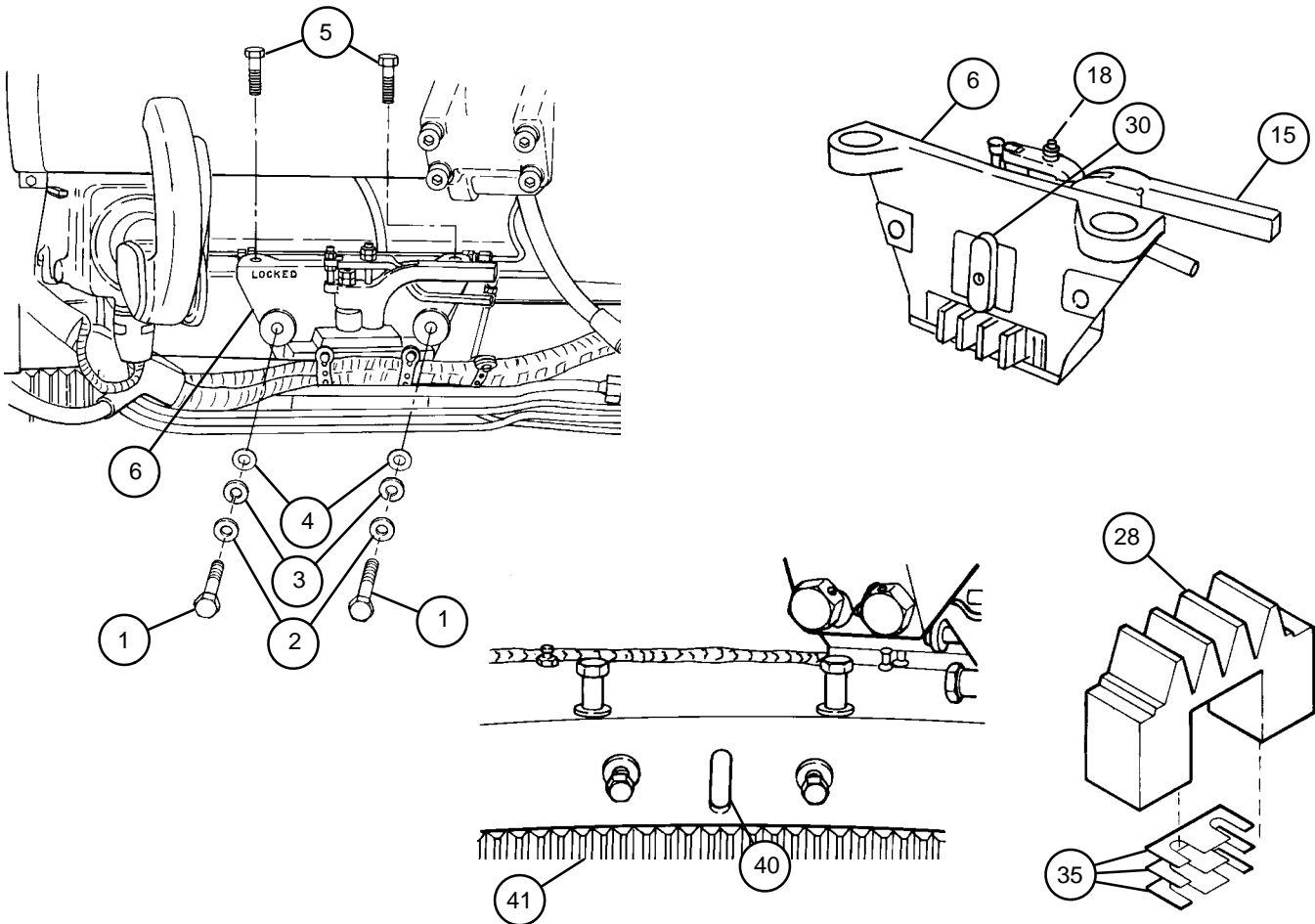
- 8 Install stud (20) onto manual control lever (15), then thread hex nut (19) onto stud (20).
- 9 Install pin assembly (18), helical compression spring (17), flat washer (16), manual control lever (15), flat washer (14), and two hex nuts (13).
- 10 Position turret lock arm (12) in clevis of manual control lever (10), align holes and drive in new spring pin (11) to secure turret lock arm. Make sure turret lock arm is free to pivot in clevis.
- 11 Slide end of manual control lever (10) into slot in manual control lever (15). End of stud (20) must protrude from hole in turret lock arm (12). Install nut (9) on stud (20).
- 12 Install nuts (7 and 8) on pin assembly (18).



## 11-1 TURRET LOCK ASSEMBLY — CONTINUED

### d. Installation

- 1 Install turret lock assembly (6) and secure using two cap screws (5), new shims (4), two new lockwashers (3), two flat washers (2), and two new self-locking bolts (1). Machine key (30) fits into hole (40) in geared race (41) to locate turret lock assembly (6) properly. Torque cap screws to 248-302 lb-ft.
- 2 Move manual control lever (15) to LOCKED position and check to be sure that teeth of gear (28) engage teeth of geared race (41) and that pin assembly (18) engages hole in turret lock assembly (6) for LOCKED position.
- 3 Vary thickness of shims (35) to adjust engagement of gear (28) with teeth of geared race (41). Decreasing thickness of shims brings gear into closer engagement with race; increasing shims thickness moves gear away from race. Shims are available in three thicknesses: 0.001, 0.002, and 0.003 inches (0.03, 0.05, and 0.08 mm).





---

## 11-2 TRAVERSING MECHANISM COVER PLATE – CONTINUED

---

### c. Assembly

**WARNING**

Adhesives can burn easily, can give off harmful vapors, and are harmful to skin and clothing. To avoid injury or death, keep away from open fire and use in well-ventilated area. If adhesive gets on skin or clothing, wash immediately with soap and water.

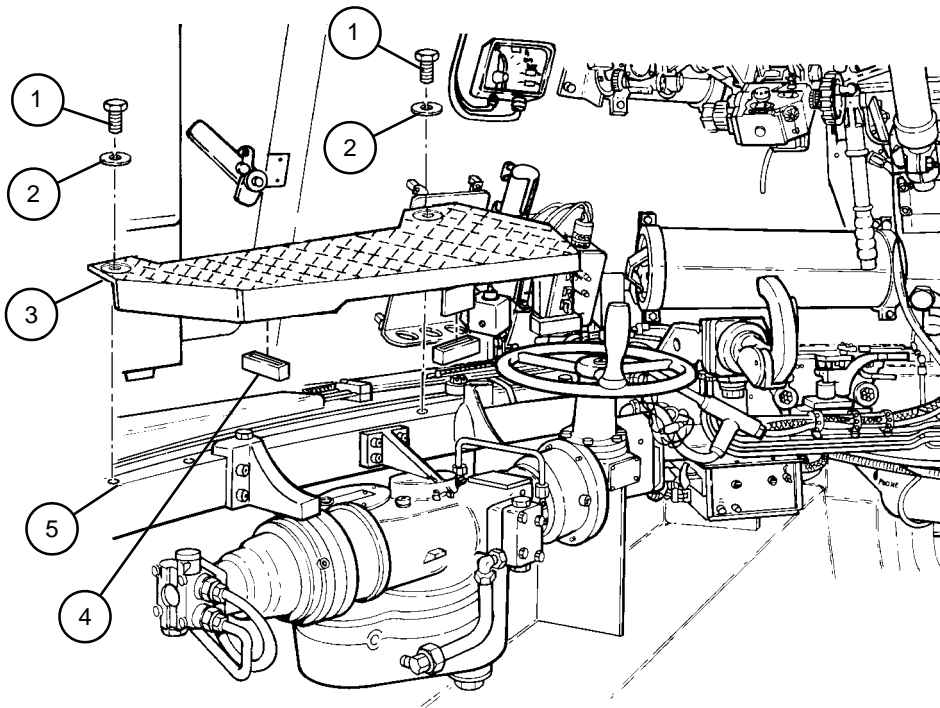
### NOTE

Clean dirt and adhesives from bonding surfaces.

Apply adhesive to two new cushioning pads (4) and cover plate (3). Attach cushioning pads to cover plate.

### d. Installation

- 1 Position cover plate (3) on traverse ring (5) alining mounting holes.
- 2 Install two flat washers (2) and two new self-locking bolts (1) in cover plate (3). Torque bolts to 248-302 lb-ft.









---

## 11-4 HANDWHEEL ASSEMBLY

---

This task covers: a. Removal

b. Installation

---

### INITIAL SETUP

#### Tools

Artillery and turret mechanic's tool kit  
(SC 5180-95-CL-A12)

#### Materials/Parts

Key washer (item 26, Appx G)

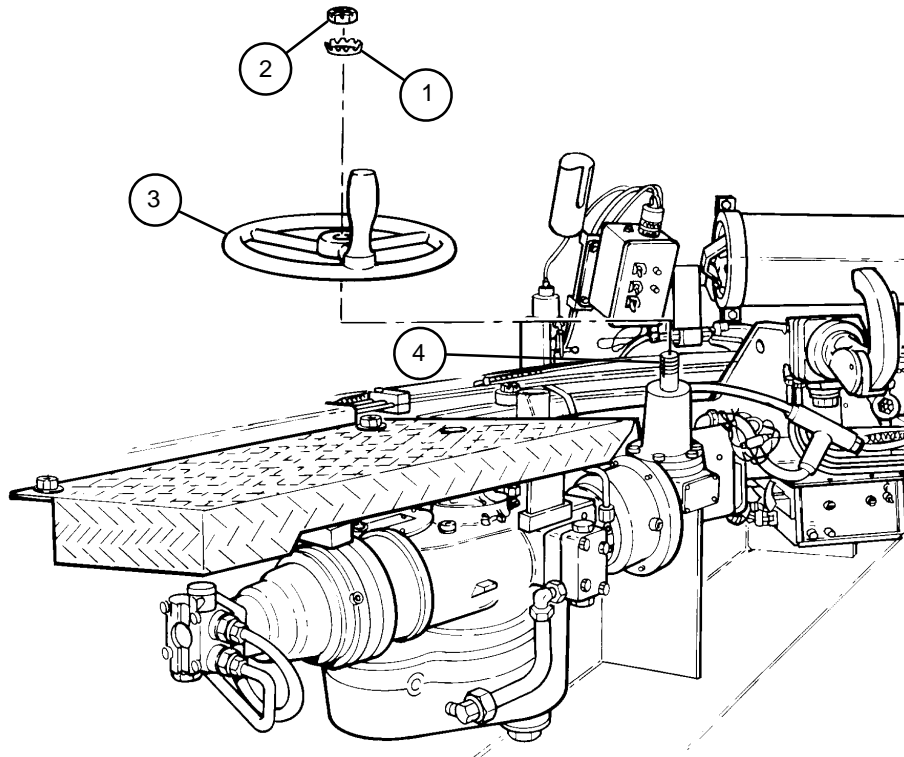
---

#### a. Removal

- 1 Unlock key washer (1).
- 2 Remove round nut (2), key washer (1), and handwheel assembly (3) from shouldered shaft (4). Discard key washer.

#### b. Installation

- 1 Install handwheel assembly (3) on shouldered shaft (4).
- 2 Install new key washer (1) and round nut (2).
- 3 Bend tab of key washer (1) over round nut (2) to lock.





## CHAPTER 12 COMMANDER'S CUPOLA

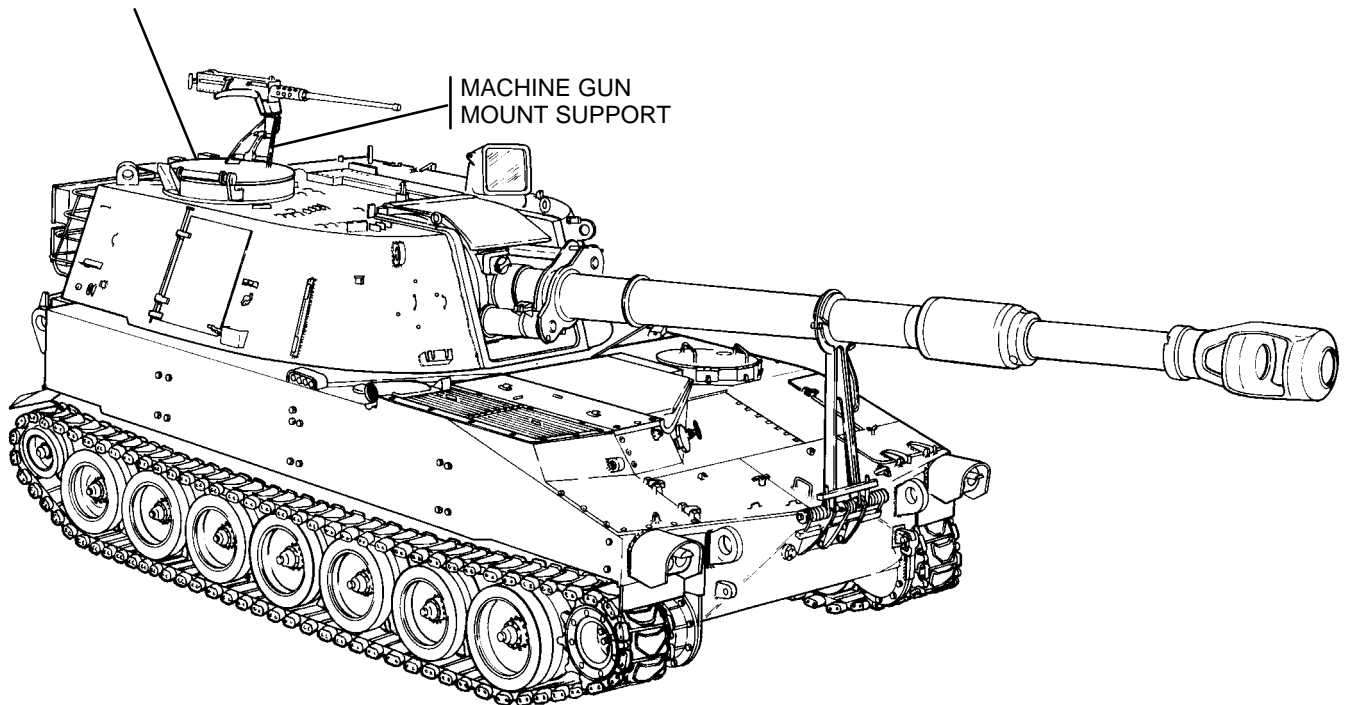
### GENERAL

This chapter illustrates and describes how to remove, disassemble, assemble, and install the machine gun mount support, adapter arm assembly, and cupola cover, body, and handle.

### CONTENTS

	<u>Page</u>
12-1 MACHINE GUN MOUNT SUPPORT .....	12-2
12-2 ADAPTER ARM ASSEMBLY .....	12-4
12-3 CUPOLA COVER, BODY, AND HANDLE .....	12-5

COMMANDER'S CUPOLA ASSEMBLY



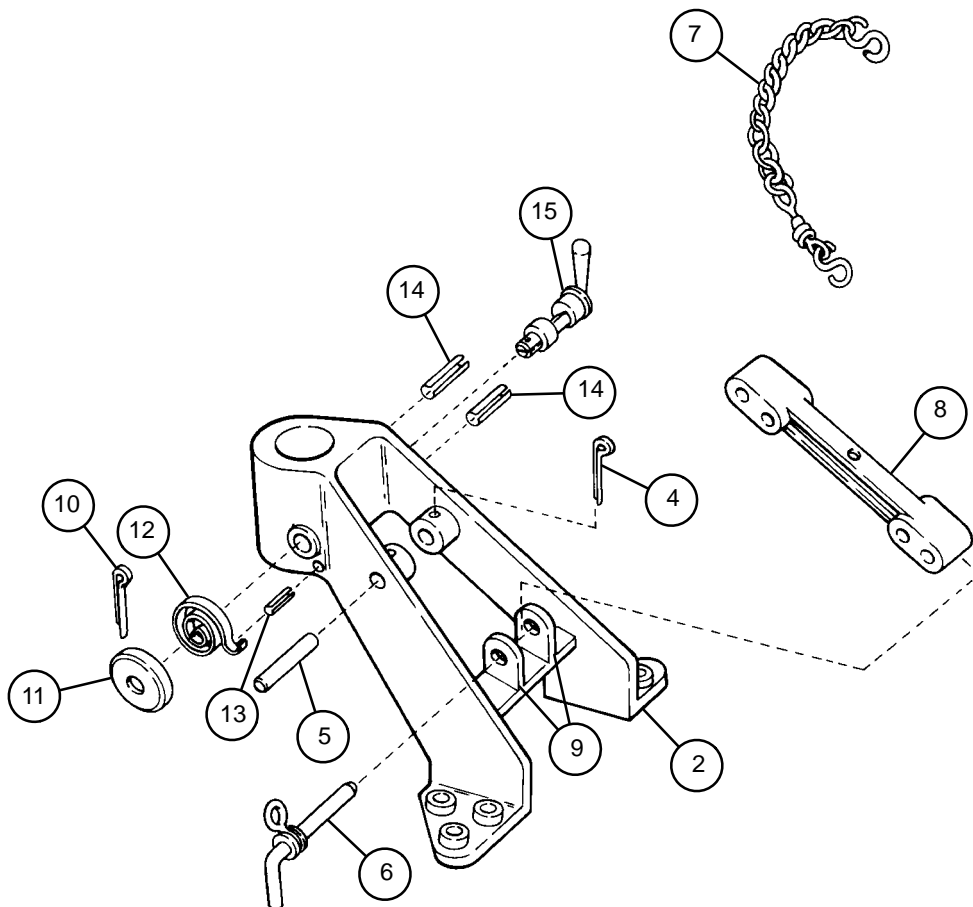


### c. Assembly

- 1 Insert manual control lever (15) into hole on mount support (2).
- 2 Install spiral torsion spring (12), new spring pin (13), and cover (11) onto manual control lever (15). Secure with new cotter pin (10).
- 3 Install two new spring pins (14) in mount support (2).
- 4 Secure top of rig connecting link (8) to mount support (2) using headless pin (5) and two new cotter pins (4).
- 5 Place bottom of rig connecting link (8) between brackets (9). Install pintle chain assembly (7) and insert quick-release pin (6) through brackets and rig connecting link.

### d. Installation

- 1 Align six screw holes on mount support (2) with screw holes on commander's cupola (3).
- 2 Install six cap screws (1) on mount support (2).



## 12-2 ADAPTER ARM ASSEMBLY

This task covers: a. Disassembly b. Assembly

### INITIAL SETUP

Tools

Artillery and turret mechanic's tool kit  
(SC 5180-95-CL-A12)

References

TM 9-2350-311-10

### NOTE

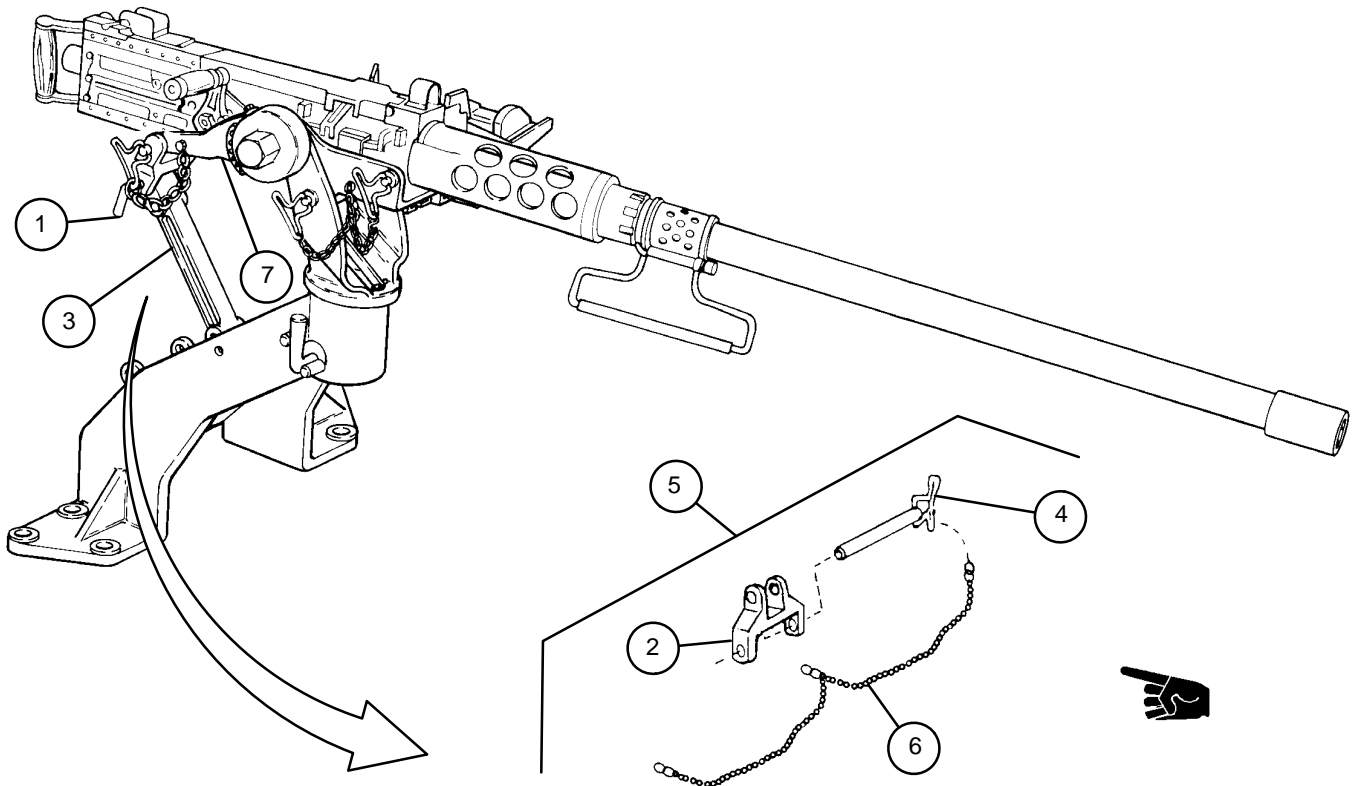
When machine gun is not installed, adapter arm assembly is stored in oddment tray inside cab.

#### a. Disassembly

- 1 Pull quick-release pin (1) from connecting link (2) and connecting link (3).
- 2 Pull quick-release pin (4) from connecting link (2) and if necessary disassemble adapter arm assembly (5) by removing chain assembly (6) from machine gun mount (7), quick-release pin, and connecting link.

#### b. Assembly

- 1 If necessary assemble adapter arm assembly (5) by installing chain assembly (6) on machine gun mount (7), quick-release pin (4), connecting link (2). Push quick-release pin into connecting link through machine gun mount.
- 2 Push quick-release pin (1) into connecting link (2) and connecting link (3).





---

## 12-3 CUPOLA COVER, BODY, AND HANDLE

---

- This task covers:
- |               |                 |
|---------------|-----------------|
| a. Removal    | b. Disassembly  |
| c. Assembly   | d. Installation |
| e. Adjustment |                 |
- 

### **INITIAL SETUP**

#### Tools

Artillery and turret mechanic's tool kit  
 ■ (SC 4933-95-A12)

#### Materials/Parts

Adhesive (item 1, Appx D)  
 Cotter pin (item 39, Appx G)  
 Cotter pins (2) (item 36, Appx G)  
 Cotter pins (2) (item 37, Appx G)  
 Cotter pins (2) (item 38, Appx G)  
 Cover seal (item 115, Appx G)  
 Cushioning pad (item 113, Appx G)  
 Epoxy (item 13.1, Appx D)  
 ■ Epoxy (item 13.2, Appx D)  
 Flat washers (V) (item 114, Appx G)  
 Flat washers (V) (item 125, Appx G)  
 Flat washers (V) (item 126, Appx G)  
 Flat washers (V) (item 127, Appx G)  
 GAA (item 17, Appx D)

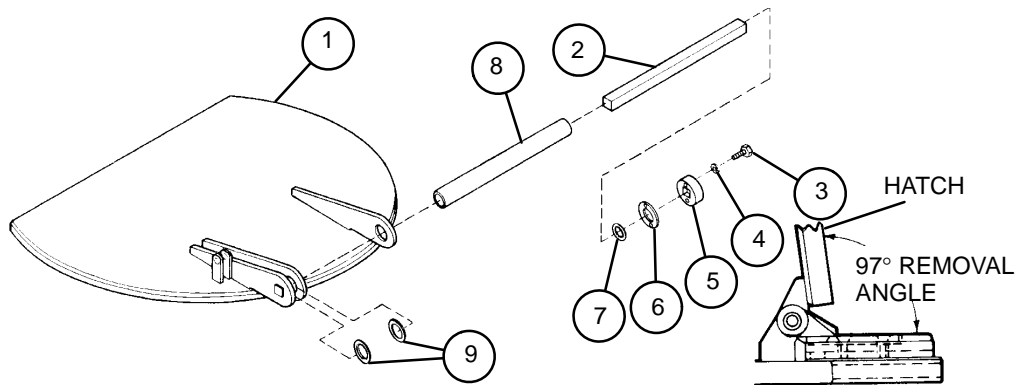
Gasket (item 172.1, Appx G)  
 Lockwashers (2) (item 56, Appx G)  
 Lockwashers (2) (item 80, Appx G)  
 Lockwashers (2) (item 96, Appx G)  
 Lockwashers (6) (item 81, Appx G)  
 Non-metallic seal (item 133, Appx G)  
 Plate spacers (V) (item 123, Appx G)  
 Plate spacers (V) (item 124, Appx G)  
 Plate spacers (V) (item 131, Appx G)  
 Plate spacers (V) (item 132, Appx G)  
 Sealant (item 26.2, Appx D)  
 Self-locking nut (item 141, Appx G)  
 Shim (V) (item 188, Appx G)  
 Shim (V) (item 189, Appx G)  
 Spacer rings (V) (item 128, Appx G)  
 Spacer rings (V) (item 129, Appx G)  
 Spacer rings (V) (item 130, Appx G)  
 Spring pin (item 9, Appx G)  
 Spring washer (item 175, Appx G)

---

## 12-3 CUPOLA COVER, BODY, AND HANDLE — CONTINUED

### a. Removal

- 1 To remove cupola cover (1), unlatch cupola cover and open to upright position. Support cupola cover in upright position to release preload on 12 flat springs (2).
- 2 Remove two cap screws (3) and two lockwashers (4). Discard lockwashers.
- 3 Remove anchor (5), plate spacers (6), and spacer rings (7). Discard spacer plates and rings.
- 4 Remove 12 flat springs (2), metallic tube (8), and flat washers (9). Discard flat washers.



**b. Disassembly**

**NOTE**

Perform step 1 for commander's cupola with hook latch assembly or steps 1.1 through 1.3 for commander's cupola with knob latch assembly.

- 1 To disassemble cupola cover (1), remove spring pin (10), and straight pin (11). Discard spring pin.
- 1.1 To disassemble cupola cover (1), remove two cap screws (11.1), two lockwashers (11.2), catch (11.3), and shims (11.4).
- 1.2 Remove two inserts (11.5) if necessary for replacement.
- 1.3 Remove decal (11.6) if necessary for replacement.

**NOTE**

Commander's cupola containing drain holes will have a gasket to remove. Commander's cupolas without drain holes will have a cover seal to remove.

- 2 Strip off cover seal or gasket (12) and discard.

**NOTE**

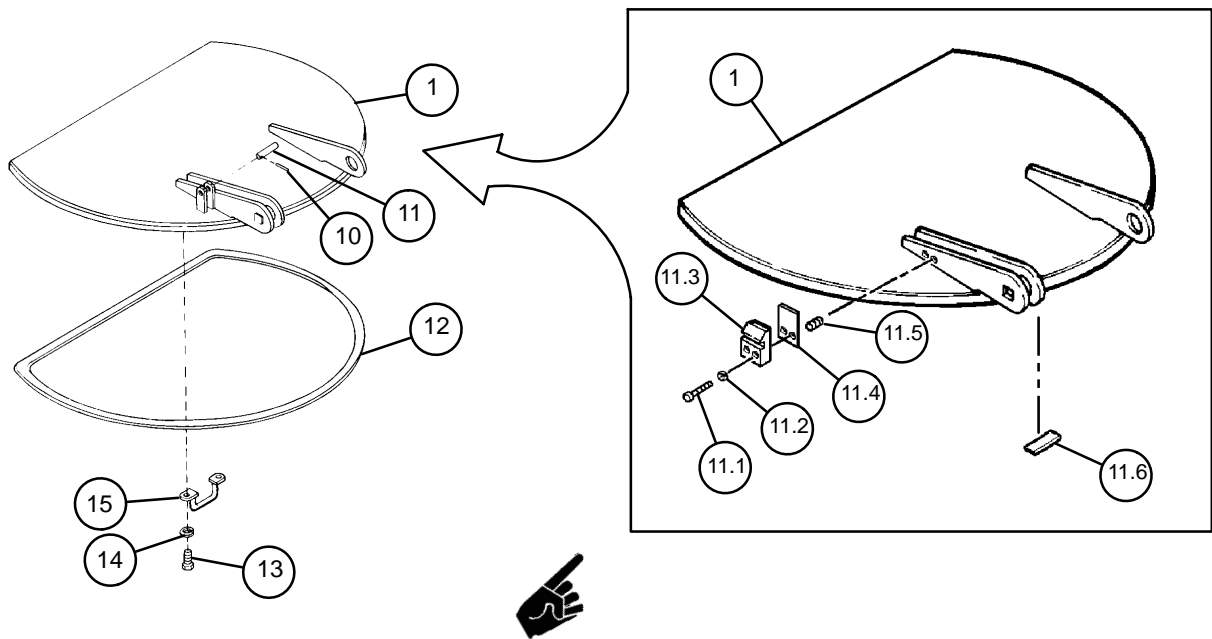
Scrape dirt and adhesive from cover seal/gasket seat.

- 3 Lift off cupola cover (1).

**NOTE**

Step 4 pertains to cupola covers without outside latch handle.

- 4 Remove two machine bolts (13), two lockwashers (14), and cupola cover handle (15). Discard lockwashers.

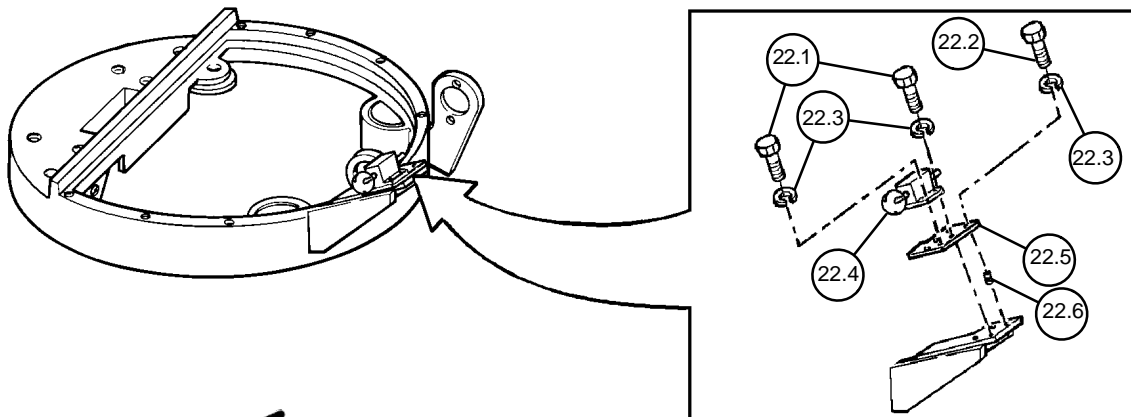
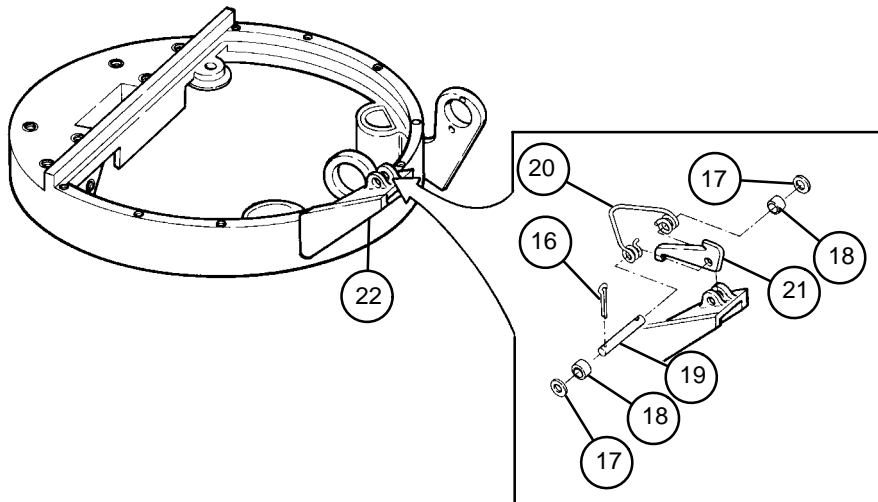


12-3 CUPOLA COVER, BODY, AND HANDLE — CONTINUED

**NOTE**

Perform step 5 for commander's cupola with hook latch assembly or steps 5.1 through 5.3 for commander's cupola with knob latch assembly.

- 5 To disassemble cupola body, remove two cotter pins (16), two flat washers (17), two sleeve spacers (18), straight pin (19), spring (20), and manual control lever (21) from latch bracket (22). Discard cotter pins.
- 5.1 Remove four cap screws (22.1), two cap screws (22.2), six lockwashers (22.3), latch assembly (22.4), and adapter plate (22.5).
- 5.2 Remove four inserts (22.6) if necessary for replacement.
- 5.3 See para 14-3 for disassembly of knob latch assembly (22.4).



**NOTE**

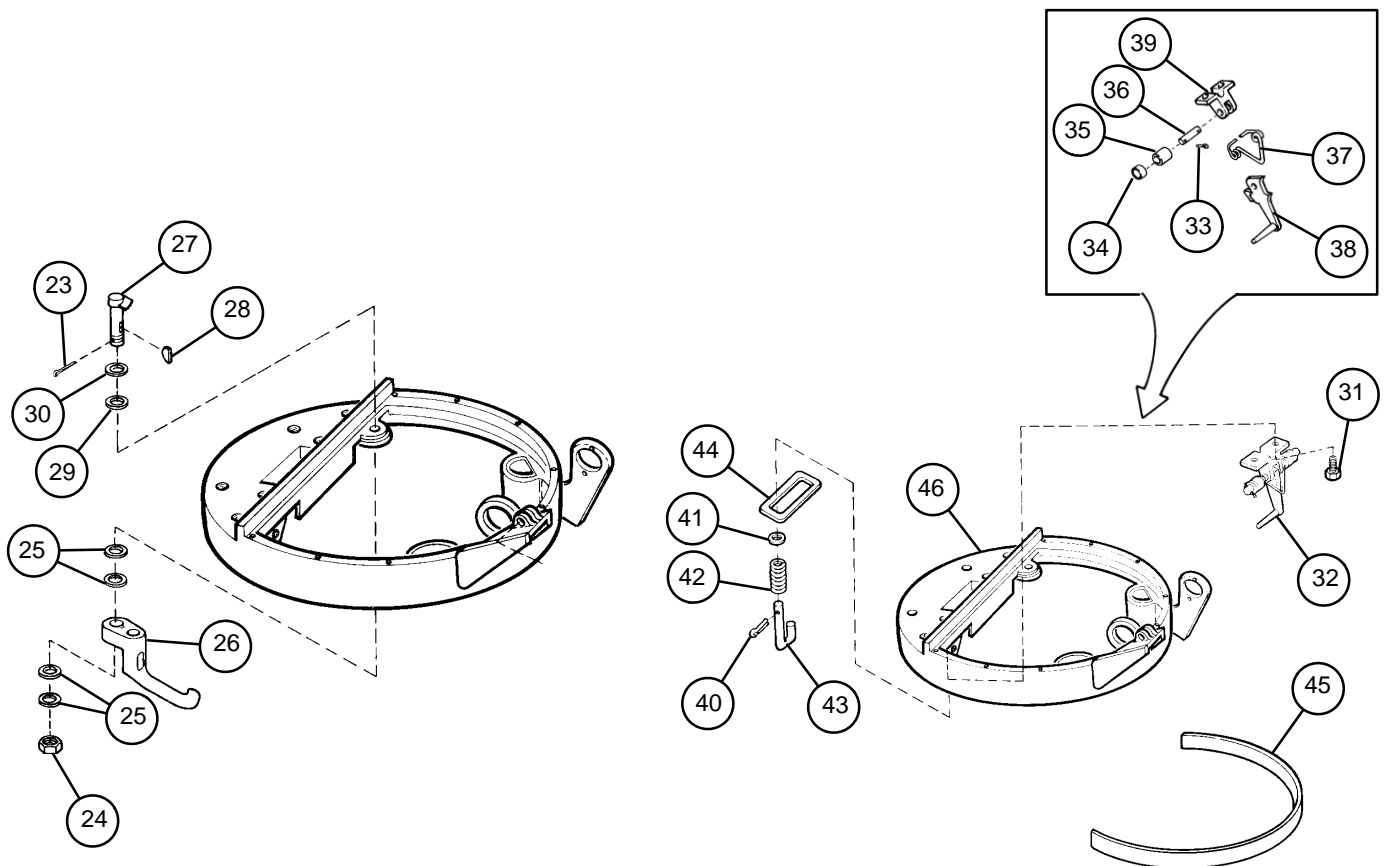
Steps 6 through 10 pertain to cupola covers without outside latch assembly.

- 6 Remove cotter pin (23), nut (24), flat washers (25), and door handle assembly (26). Discard cotter pin.
- 7 Remove cupola handle cam (27), key (28), flat washer (29), and spring washer (30). Discard spring washer.
- 8 Remove two cap screws (31) and locking latch (32).
- 9 To disassemble locking latch (32), remove two cotter pins (33), two flat washers (34), two sleeve spacers (35), straight pin (36), helical torsion spring (37), and cupola latch (38) from latch bracket (39). Discard two cotter pins.
- 10 Remove two cotter pins (40), two flat washers (41), two springs (42), and two support hooks (43). Discard two cotter pins.
- 11 Strip off non-metallic seal (44) and discard.

**NOTE**

Clean dirt and adhesives from seal seat.

- 12 Separate cushioning pad (45) from cupola body assembly (46). Discard cushioning pad.



---

## 12-3 CUPOLA COVER, BODY, AND HANDLE — CONTINUED

---

### b. Disassembly — Continued

#### NOTE

Steps 13 through 17 pertain to cupola covers with outside latch handle.

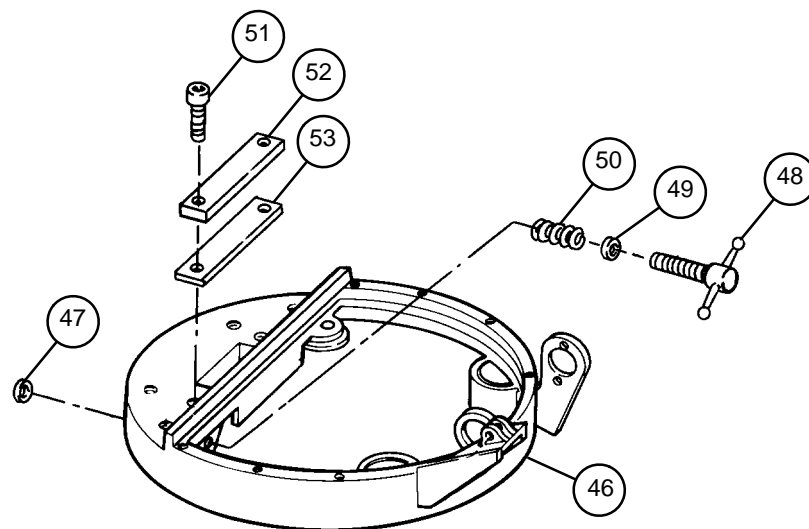
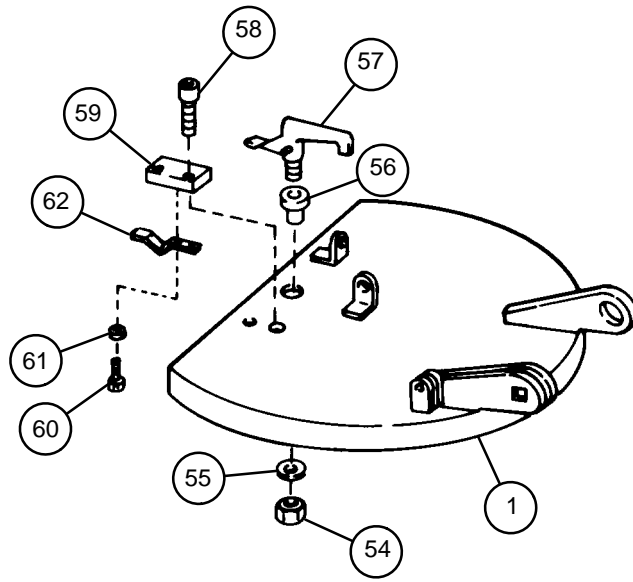
- 13 Remove shoe assembly (47), screw assembly (48), flat washer (49), and helical compression spring (50) from cupola body assembly (46).
- 14 Remove two cap screws (51), cupola cover block (52), and plate spacers (53) from cupola body assembly (46). Discard plate spacers.
- 15 Remove self-locking nuts (54), flat washer (55), sleeve bearing (56), and door handle (57) from cupola cover (1). Discard self-locking nuts.
- 16 Remove two cap screws (58) and block latch lock (59) from cupola cover (1).
- 17 Remove two machine bolts (60), two lockwashers (61), and flat spring (62) from block latch lock (59). Discard lockwashers.

### c. Assembly

#### NOTE

Steps 1 through 5 pertain to cupola covers with outside latch handle.

- 1 Secure flat spring (62) to block latch lock (59) using two new lockwashers (61) and two machine bolts (60).
- 2 Secure block latch lock (59) to cupola cover (1) using two cap screws (58).
- 3 Install sleeve bearing (56), door handle (57), flat washer (55), and new self-locking nut (54) to cupola cover (1).
- 4 Secure new plate spacer (53), cupola cover block (52), and two cap screws (51) to cupola body assembly (46).
- 5 Install helical compression spring (50), flat washer (49), screw assembly (48), and shoe assembly (47).



12-3 CUPOLA COVER, BODY, AND HANDLE — CONTINUED

c. Assembly — Continued

**WARNING**

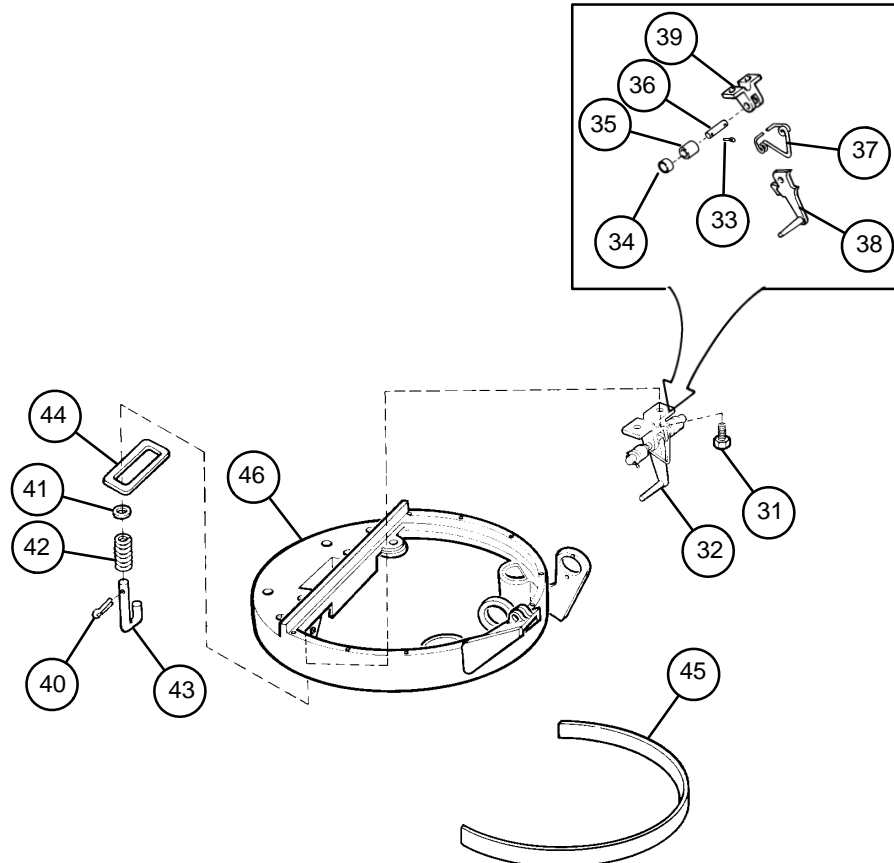
Adhesives can burn easily, can give off harmful vapors, and are harmful to skin and clothing. To avoid injury or death, keep away from open fire and use in well-ventilated area. If adhesive gets on skin or clothing, wash immediately with soap and water.

- 6 Apply adhesive to new cushioning pad (45) and cupola body assembly (46). Allow to set for 15 minutes, then attach cushioning pad to cupola body assembly.
- 7 Apply adhesive to new non-metallic seal (44), then install onto clean seal seat.

**NOTE**

Steps 8 through 12 apply to cupola covers without outside handle.

- 8 Install two support hooks (43), two springs (42), and two flat washers (41). Install two new cotter pins (40).
- 9 Install cupola latch (38), helical torsion spring (37), straight pin (36), two sleeve spacers (35), two flat washers (34) onto latch bracket (39). Install two new cotter pins (33).
- 10 Install locking latch (32) and two cap screws (31).



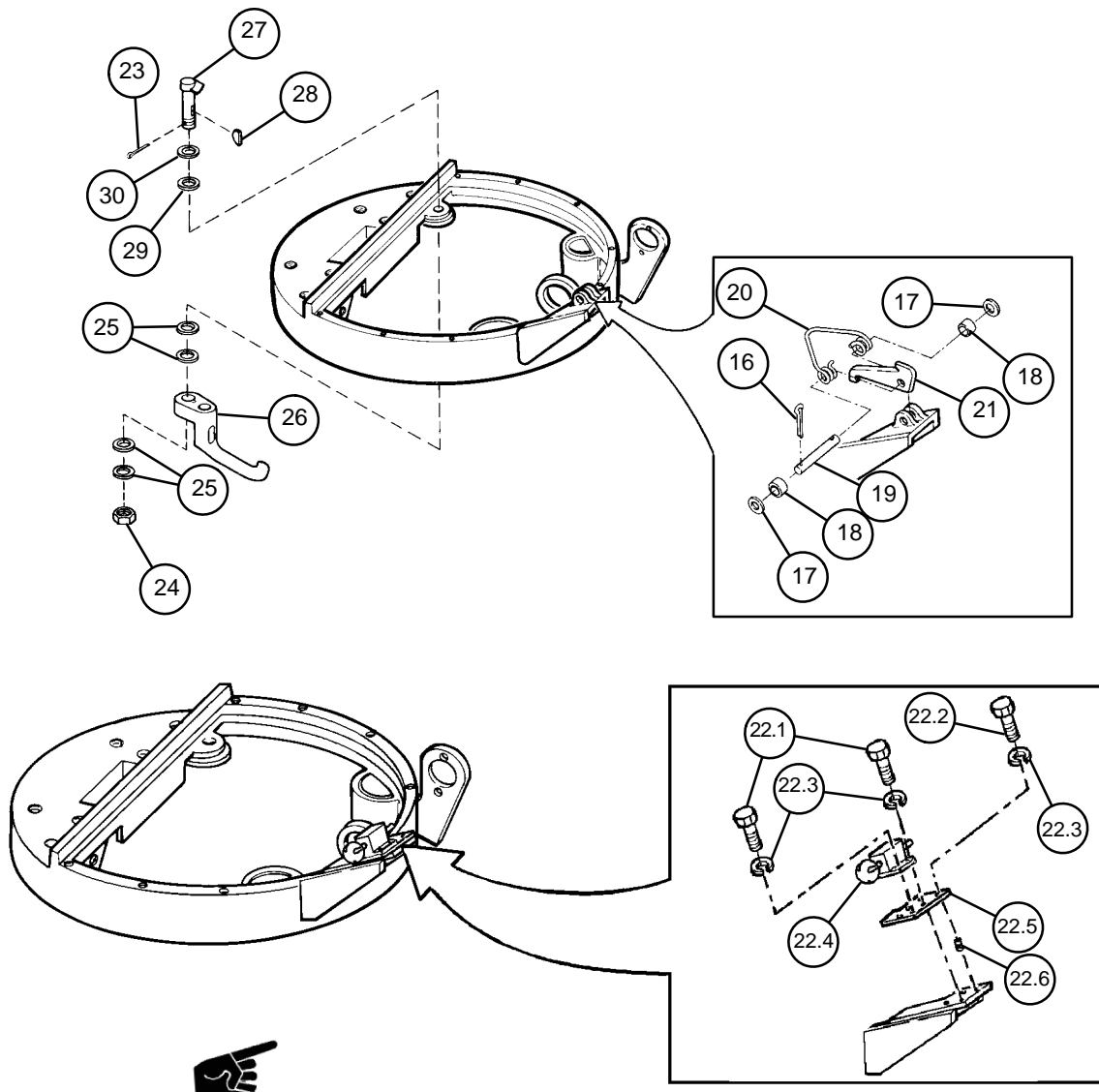


- 11 Install new spring washer (30), flat washer (29), key (28), and cupola handle cam (27).
- 12 Install flat washers (25), door handle assembly (26), flat washers (25), and nut (24). Install new cotter pin (23).

**NOTE**

Perform step 13 for commander's cupola with hook latch assembly or steps 13.1 through 13.3 for commander's cupola with knob latch assembly.

- 13 Install manual control lever (21), spring (20), straight pin (19), two sleeve spacers (18), and two flat washers (17). Install two new cotter pins (16).
- 13.1 See para 14-3 for assembly of knob latch assembly (22.4).
- 13.2 Install four inserts (22.6) if removed.
- 13.3 Install adapter plate (22.5), latch assembly (22.4), six new lockwashers (22.3), two cap screws (22.2), and four cap screws (22.1).



## 12-3 CUPOLA COVER, BODY, AND HANDLE — CONTINUED

### c. Assembly — Continued

**NOTE**

Step 14 applies to cupola covers without outside handle.

- 14 Install cupola cover handle (15) using two new lockwashers (14) and two machine bolts (13).

**WARNING**

Adhesives can burn easily, can give off harmful vapors, and are harmful to skin and clothing. To avoid injury or death, keep away from open fire and use in well-ventilated area. If adhesive gets on skin or clothing, wash immediately with soap and water.

**NOTE**

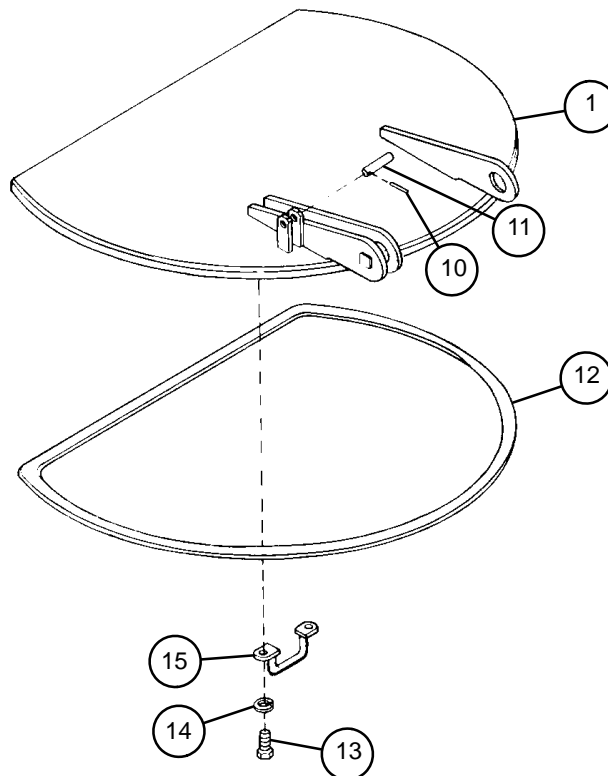
If commander's cupola does not have drain holes perform step 15. If commander's cupola has drain holes perform step 15.1.

- 15 Apply adhesive to new cover seal (12) and cupola cover (1). Allow to set 15 minutes then attach cover seal to cupola cover.
- 15.1 Apply epoxy adhesive to new gasket (12) and cupola cover (1). Allow to set 15 minutes then attach gasket to cupola cover.

**NOTE**

Perform step 16 for commander's cupola with hook latch assembly or steps 16.1 through 16.3 for commander's cupola with knob latch assembly.

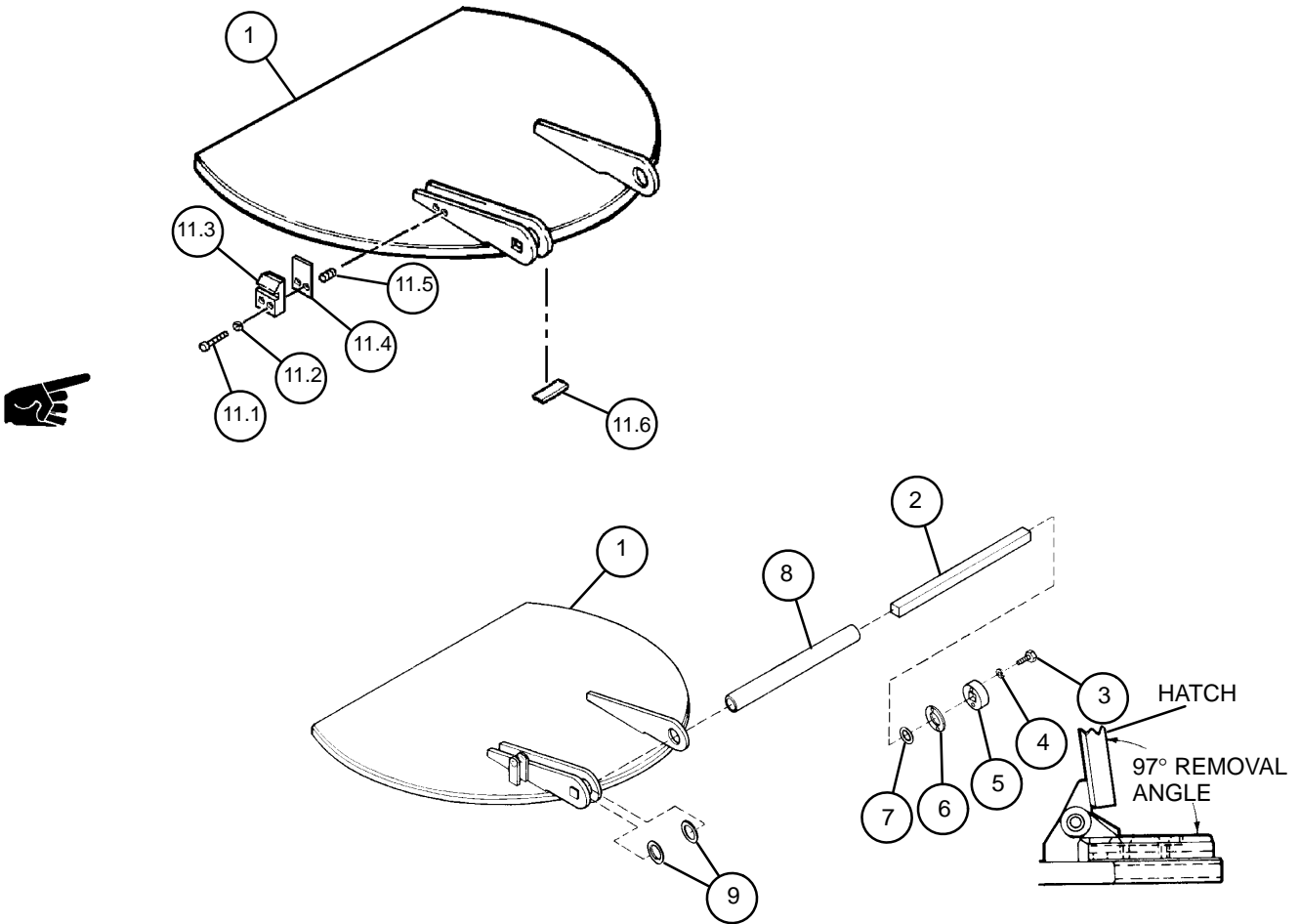
- 16 Install straight pin (11) and new spring pin (10).



- 16.1 Refer to para 2-7 for procedures on installing decal (11.6), if removed.
- 16.2 Install two inserts (11.5) if removed.
- 16.3 Install shims (11.4), catch (11.3), two new lockwashers (11.2), and two cap screws (11.1).

**d. Installation**

- 1 To install cupola cover (1), support cupola cover in upright position. Install flat washers (9) and metallic bar tube (8).
- 2 Coat 12 flat springs (2) with grease. Install 12 flat springs with cupola cover (1) at a 97° angle from closed position.
- 3 Install spacer rings (7), spacer plates (6), and anchor (5).
- 4 Install two new lockwashers (4) and two cap screws (3).
- 5 Close cupola cover (1) and engage latch to keep cupola cover in position.



12-3 CUPOLA COVER, BODY, AND HANDLE — CONTINUED

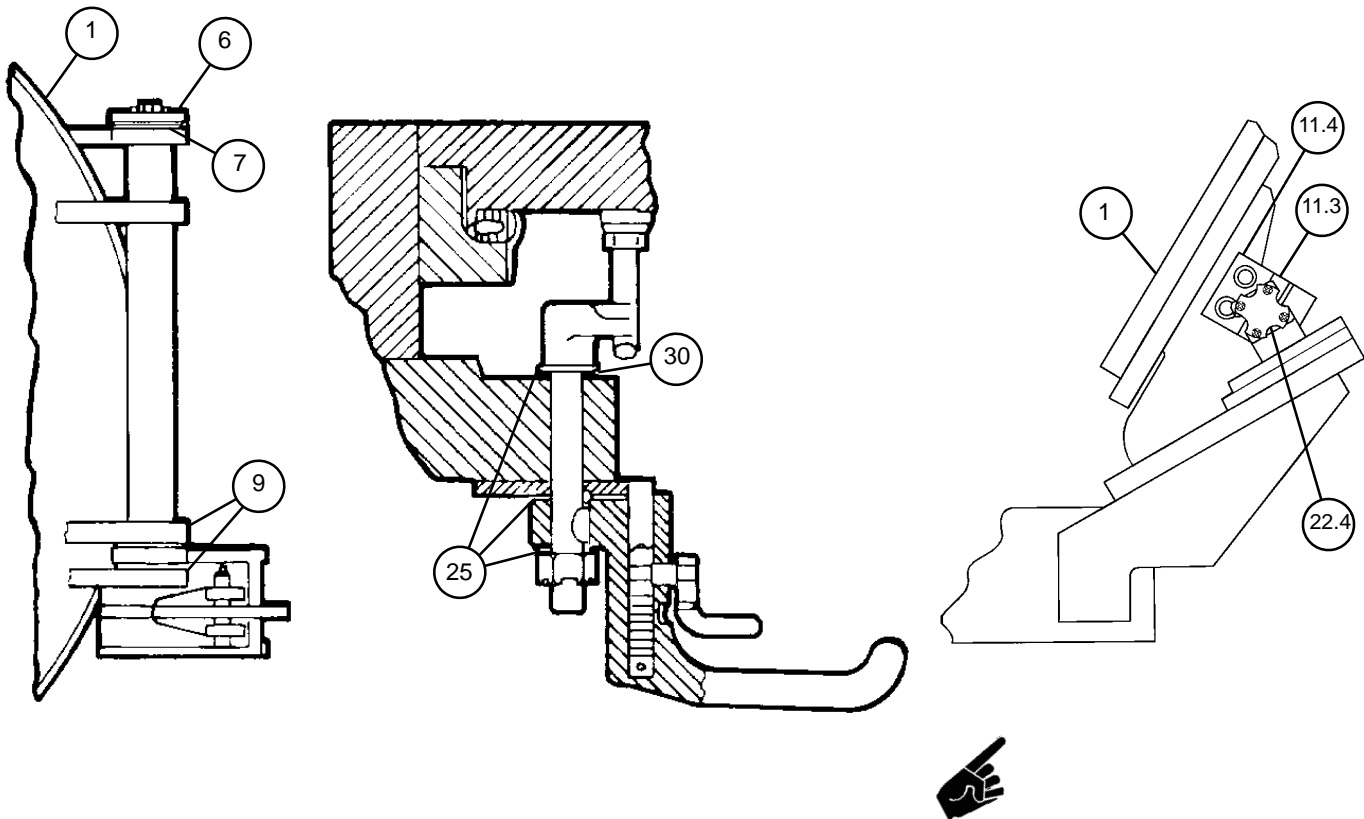
e. Adjustment

- 1 To adjust anchor/torsion bar assembly on cupola cover (1), insert new spacer plate(s) (6) as required. Provide a 0.016 + 0.063 inch (0.406 + 1.6 mm) clearance between spring ends and anchor.
- 2 Insert new spacer ring(s) (7) as required. Provide a 0.005 + 0.200 inch (0.127 + 5.08 mm) clearance between tube end and cover hinge.
- 3 Insert new flat washer(s) (9) as required. Center hatch in cupola body within 0.047 inch (1.2 mm).
- 4 Insert new flat washers(s) (25) as required. Provide spring washer (30) depression of approximately 0.031 inch (0.79 mm) in UNLOCK position.

**NOTE**

Step 5 pertains to commander's cupola assemblies which have been modified and use the knob latch assembly.

- 5 To adjust catch/latch assembly on cupola cover (1) when secured in open position, insert shims (11.4) as required. Provide a 0.06 to 0.12 inch (1.524 to 3.048 mm) clearance between end of plunger of latch assembly (22.4) and to back of slot in catch (11.3).



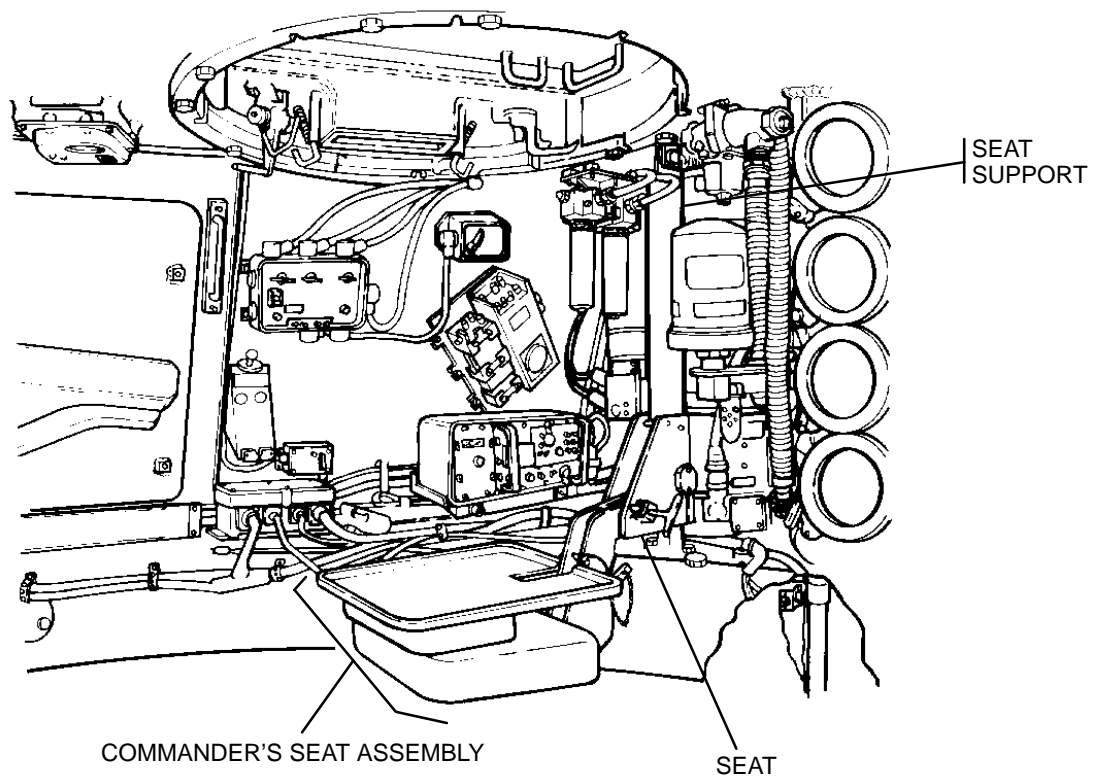
## CHAPTER 13 COMMANDER'S SEAT ASSEMBLY

### GENERAL

This chapter gives detailed instructions on how to remove, disassemble, assemble, install, and adjust the commander's seat and support post group. It also details procedures for repair of seat parts and the seat adjuster assembly.

### CONTENTS

	<u>Page</u>
13-1    COMMANDER'S SEAT AND SUPPORT POST GROUP .....	13-2
13-2    COMMANDER'S SEAT ASSEMBLY (SEAT PARTS ONLY) .....	13-7
13-3    SEAT ADJUSTER ASSEMBLY .....	13-8



---

## 13-1 COMMANDER'S SEAT AND SUPPORT POST GROUP

---

This task covers:

a. Removal	b. Disassembly
c. Assembly	d. Installation
e. Adjustment	

---

### **INITIAL SETUP**

#### Tools

Artillery and turret mechanic's tool kit  
(SC 5180-95-CL-A12)

#### Materials/Parts

Lockwasher (item 84, Appx G)  
Lockwashers (4) (item 79, Appx G)  
Lockwashers (4) (item 81, Appx G)

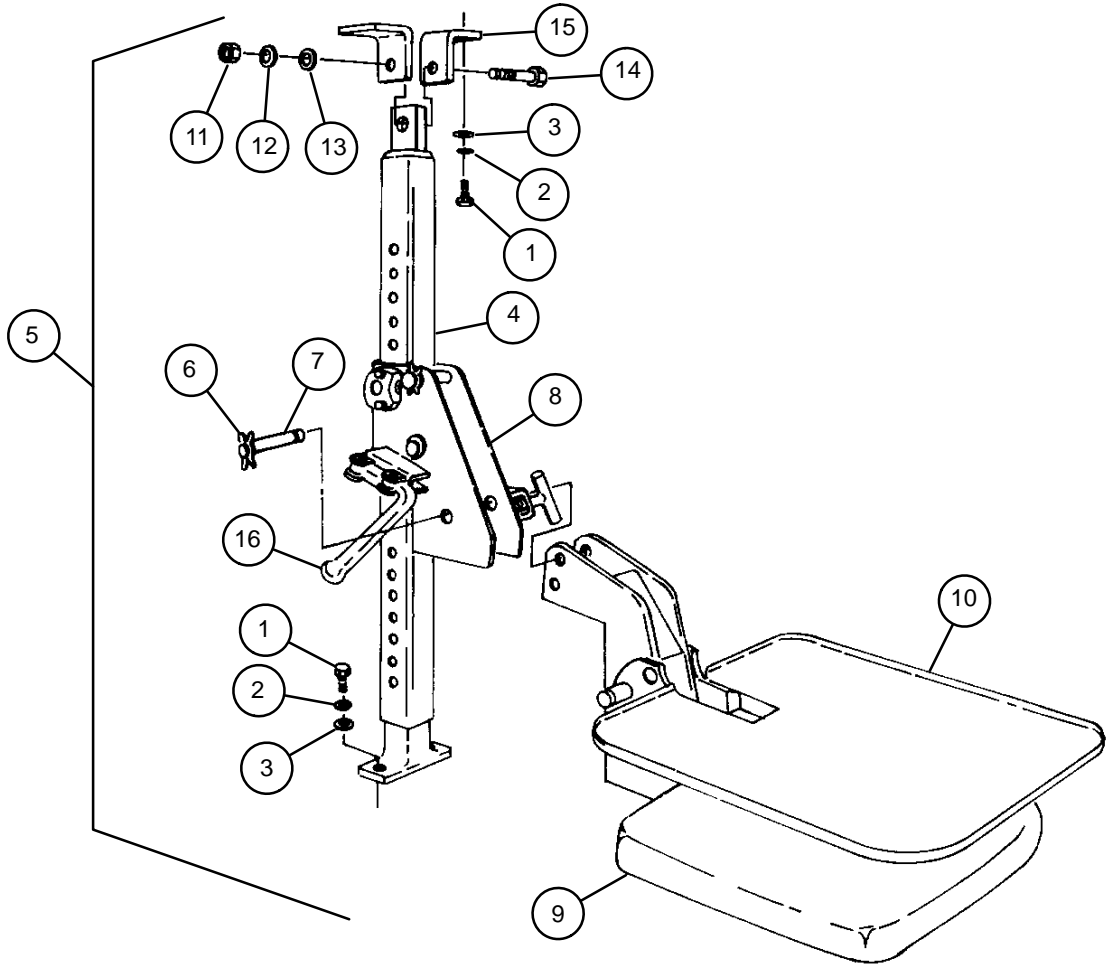
---

#### **a. Removal**

#### **NOTE**

Except for adjusting the seat, perform the procedures in this paragraph only if the entire seat needs repair.

- 1 Remove four cap screws (1) four lockwashers (2), and four flat washers (3) from top and bottom of seat support (4). Entire commander's seat assembly (5) will now come off. Discard lockwashers.
- 2 Remove permanent washer (6) and headless shoulder pin (7) from seat carriage (8). This will release seat (9) and backrest (10) (assembled).
- 3 Remove hex nut (11), lockwasher (12), flat washer (13), cap screw (14), and two angle brackets (15). Discard lockwasher.
- 4 Pull manual control handle (16) toward you and slide seat carriage (8) upward to remove from seat support (4).



---

**13–1 COMMANDER’S SEAT AND SUPPORT POST GROUP — CONTINUED**

---

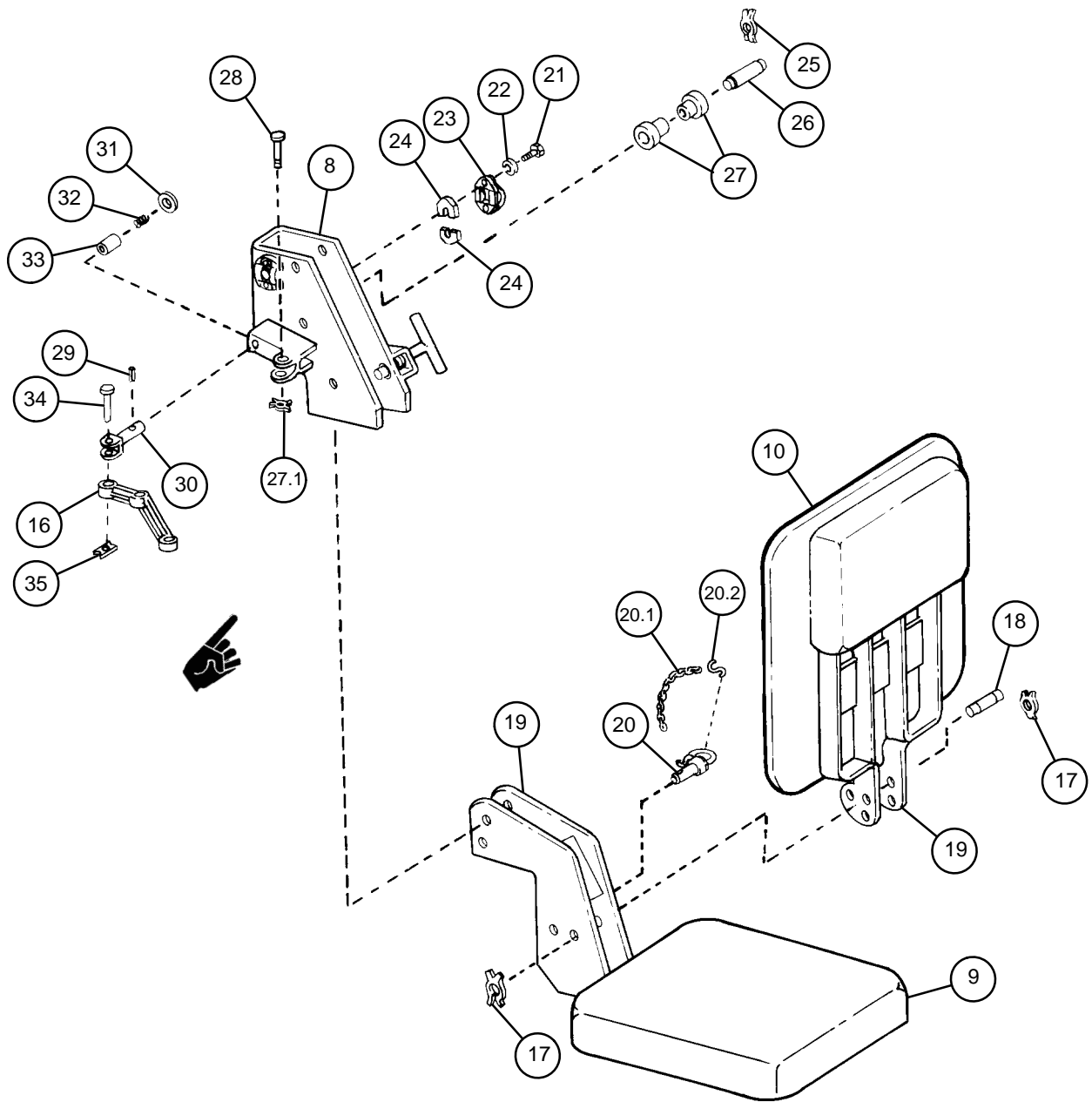
**b. Disassembly**

- 1 Remove two permanent washers (17) and headless shoulder pin (18) from brackets (19) on seat (9) and backrest (10).
- 2 Withdraw quick-release pin (20), remove chain (20.1) and s-hook (20.2) from brackets (19) on seat (9) and backrest (10).
- 3 Separate backrest (10) from seat (9).
- 4 Remove four machine screws (21), four lockwashers (22), two rollers (23), and nut and bolt retainers (24) from seat carriage (8). Discard lockwashers.
- 5 Remove permanent washer (25), headless shoulder pin (26), and two rollers (27) from seat carriage (8). Discard permanent washer.
- 6 Remove x-washer (27.1) and headed grooved pin (28) from manual control handle (16) on seat carriage (8).
- 7 Remove headless grooved pin (29) from rod end clevis (30) on seat carriage (8). This will release flat washer (31), spring (32), and sleeve bushing (33).
- 8 Remove headed grooved pin (34) and x-washer (35) from rod end clevis (30) to release manual control handle (16).

**c. Assembly**

- 1 Install rod end clevis (30) on manual control handle (16) using headed grooved pin (34) and x-washer (35).
- 2 Install sleeve bushing (33), spring (32), and flat washer (31) on rod end clevis (30). Install rod end clevis on seat carriage (8) using headless grooved pin (29).
- 3 Install headed grooved pin (28) and x-washer (27.1) on manual control handle (16).
- 4 Install headless shoulder pin (26), two rollers (27), and new permanent washer (25) on seat carriage (8).
- 5 Using four machine screws (21), four new lockwashers (22), and nut and bolt retainers (24), install two rollers (23) on seat carriage (8).
- 6 Install backrest (10) on seat (9) using quick-release pin (20), chain (20.1) and s-hook (20.2).
- 7 Install headless shoulder pin (18) and two permanent washers (17) on brackets (19).





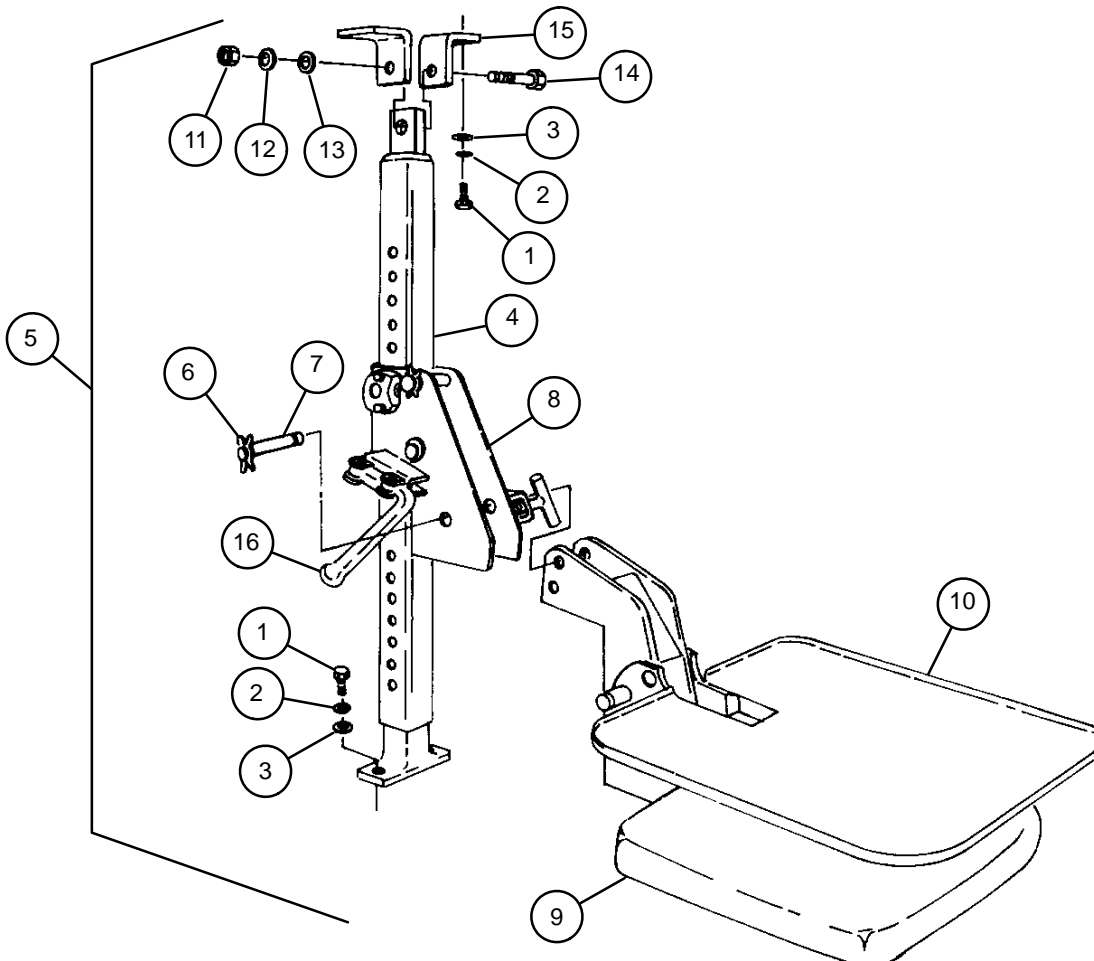
## 13-1 COMMANDER'S SEAT AND SUPPORT POST GROUP — CONTINUED

### d. Installation

- 1 Install seat carriage (8) on seat support (4). Seat carriage will slide down seat support when manual control handle (16) is pulled toward you.
- 2 Install two angle brackets (15) at top of seat support (4) using one cap screw (14), flat washer (13), new lockwasher (12), and hex nut (11).
- 3 Install seat (9) and backrest (10) (assembled) on seat carriage (8) using headless shoulder pin (7) and permanent washer (6).
- 4 Attach commander's seat assembly (5) to cab using four flat washers (3), four new lockwashers (2), and four cap screws (1) on either end of seat support (4).

### e. Adjustment

Height of seat (9) and backrest (10) can be adjusted by moving seat carriage (8) up and down seat support (4). To move seat and backrest vertically, pull manual control handle (16) toward you. When seat and backrest are at desired height, release manual control handle.



---

## 13-2 COMMANDER'S SEAT ASSEMBLY (SEAT PARTS ONLY)

---

This task covers: a. Disassembly b. Assembly

### INITIAL SETUP

#### Tools

Artillery and turret mechanic's tool kit  
(SC 5180-95-CL-A12)

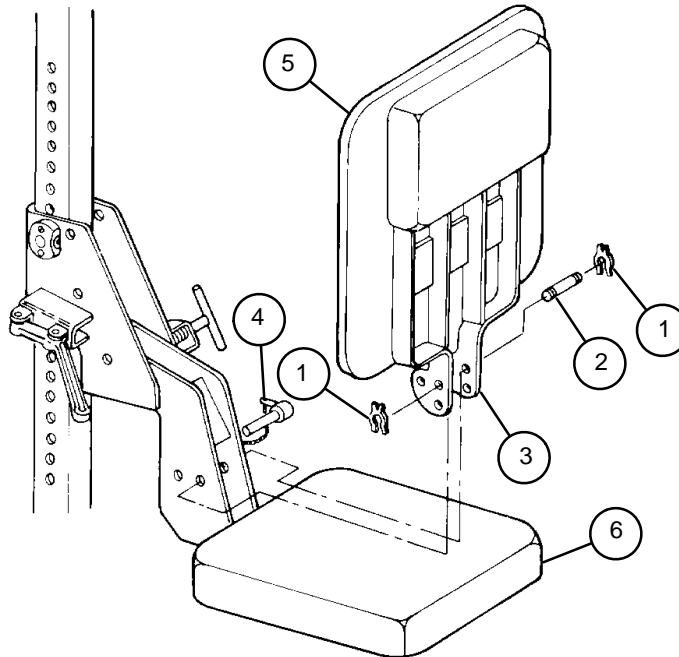
---

#### a. Disassembly

- 1 Remove two permanent washers (1) and headless shoulder pin (2) from brackets (3).
- 2 Withdraw quick-release pin (4). Backrest (5) will now separate from seat (6).

#### b. Assembly

- 1 Position backrest (5) on seat (6).
- 2 Install quick-release pin (4).
- 3 Install headless shoulder pin (2) and two permanent washers (1) in brackets (3).



## 13-3 SEAT ADJUSTER ASSEMBLY

This task covers: a. Disassembly b. Assembly

### INITIAL SETUP

#### Tools

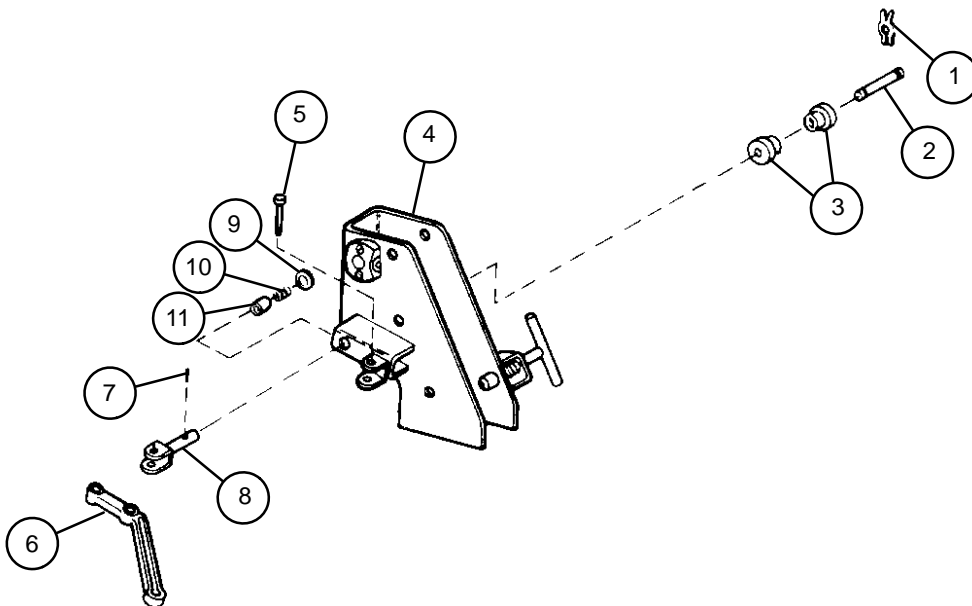
Artillery and turret mechanic's tool kit  
(SC 5180-95-CL-A12)

#### a. Disassembly

- 1 Remove permanent washer (1), headless shoulder pin (2), and two rollers (3) from seat carriage (4).
- 2 Remove headed grooved pin (5) from manual control handle (6) on seat carriage (4).
- 3 Remove headless grooved pin (7) from rod end clevis (8). This will release manual control handle (6) along with flat washer (9), spring (10), and sleeve bushing (11).

#### b. Assembly

- 1 Install sleeve bushing (11), spring (10), flat washer (9), and manual control handle (6). Install headless grooved pin (7) in rod end clevis (8).
- 2 Position manual control handle (6) on seat carriage (4) and install headed grooved pin (5).
- 3 Install two rollers (3), headless shoulder pin (2), and permanent washer (1) on seat carriage (4).



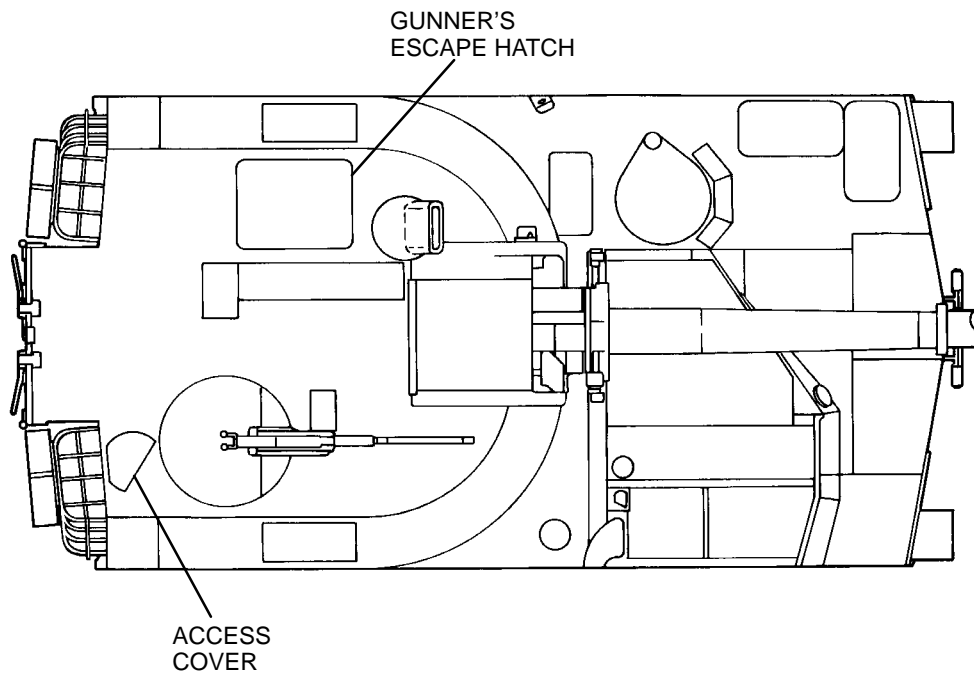
## CHAPTER 14 DOOR AND HATCH ASSEMBLIES

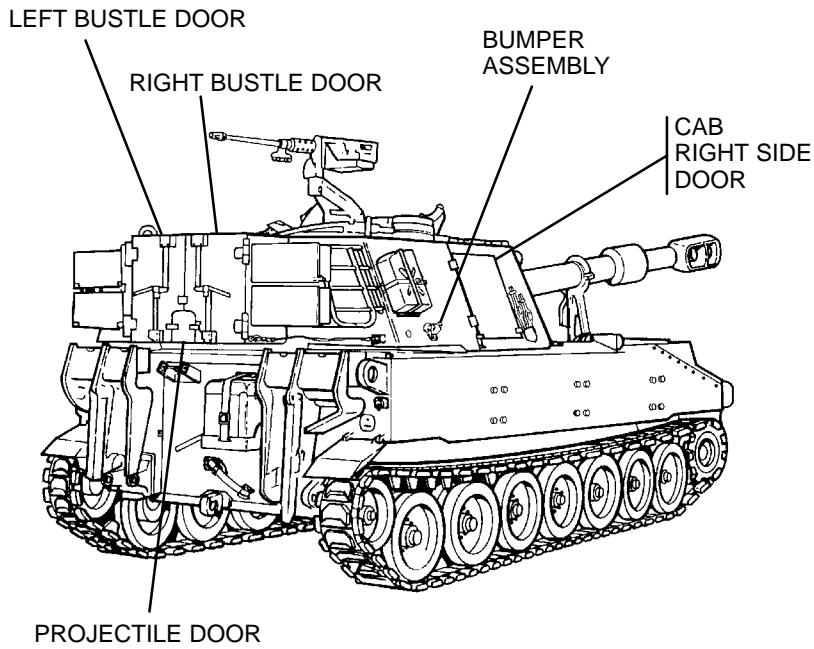
### GENERAL

This chapter illustrates and describes step-by-step maintenance procedures for the howitzer cab door and hatch assemblies.

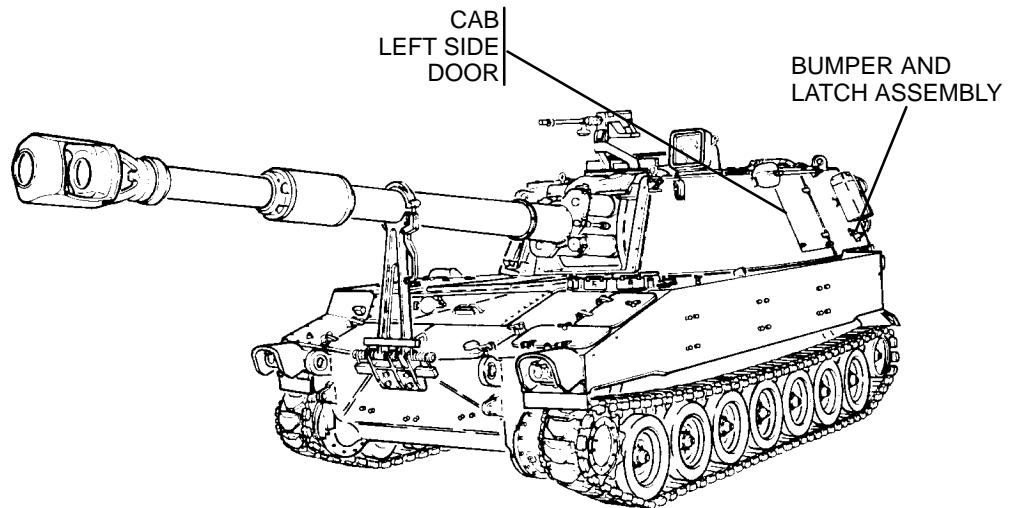
### CONTENTS

	<u>Page</u>
14-1 GUNNER'S ESCAPE HATCH (UNMODIFIED) .....	14-3
14-2 GUNNER'S ESCAPE HATCH (MODIFIED) .....	14-7
14-3 LATCH ASSEMBLY, SIDE DOORS .....	14-14
14-4 BUMPER ASSEMBLY, SIDE DOORS .....	14-16
14-5 CAB SIDE DOORS, LEFT AND RIGHT .....	14-17
14-6 CAB BUSTLE DOOR GROUP (STRIKE AND BRACKET ASSEMBLIES) .....	14-21
14-7 DOOR ASSEMBLY, PROJECTILE ACCESS .....	14-24
14-8 BUSTLE DOOR ASSEMBLIES, LEFT AND RIGHT .....	14-26
14-9 BUSTLE DOOR ARM CLEVIS ASSEMBLY .....	14-31
14-10 BUSTLE DOOR WIRE ROPE ASSEMBLIES, LEFT AND RIGHT .....	14-32
14-11 CAB ACCESS COVER .....	14-33





RIGHT REAR AND SIDE VIEWS, EXTERNAL



LEFT FRONT AND SIDE VIEWS, EXTERNAL



---

**14–1 GUNNER’S ESCAPE HATCH (UNMODIFIED) — CONTINUED**

---

**b. Disassembly****NOTE**

Some vehicles do not have bumper.

- 1 If present, remove bumper (11) on gunner’s escape hatch (1) by unscrewing.

**NOTE**

Depending on which configuration of the gunner’s escape hatch is being disassembled, perform either step 2 or step 3.

- 2 Remove two cotter pins (12), two headed straight pins (13), bumper (14), pawl (15), and torsion helical spring (16) from cab roof. Discard cotter pins. 2
- 3 Remove two retaining rings (17), headless grooved pin (18), pawl (19), and torsion helical spring (20) from cab roof. Discard retaining rings.
- 4 Remove two cap screws (21), plate spacer (22), and plate spacer(s) (23) from inside roof of cab.
- 5 Remove and discard seal (24) from gunner’s escape hatch (1).

**NOTE**

Depending on which configuration of the gunner’s escape hatch is being disassembled, perform either step 6 or step 7.

- 6 Remove self-locking nut (25), flat washer (26), and door handle (27) from door handle mounting (28). Remove knob (29), compression helical spring (30), and threaded straight pin (31) from door handle (27). Remove two cap screws (32), door handle mounting, and plate spacer (33). Discard self-locking nut.
- 7 Remove self-locking nut (34), flat washer (35), lock-release lever (36), and thrust washer bearing (37) from shoulder bolt (38). Remove shoulder bolt, thrust washer bearing (39), preformed packing (40), and sleeve bearing (41). Discard self-locking nut and preformed packing.

**c. Assembly****NOTE**

Depending on which configuration of the gunner’s escape hatch is being assembled, if step 1 is performed skip steps 2 through 4.

- 1 Install sleeve bearing (41), new preformed packing (40), thrust washer bearing (39), and shoulder bolt (38). Install thrust washer bearing (37), lock-release lever (36), flat washer (35), and new self-locking nut (34) onto shoulder bolt (38).
- 2 Apply sealing compound (item 30, Appx D), to threads of knob (29). Attach compression helical spring (30) and knob to door handle (27) using threaded straight pin (31).
- 3 Install door handle (27), flat washer (26), and new self-locking nut (25) on door handle mounting (28).



- 4 Install two cap screws (32) to join plate spacer (33) to door handle mounting (28). Add or subtract plate spacers (33) as necessary for secure fit of door handle (27) on door mounting handle.

**WARNING**

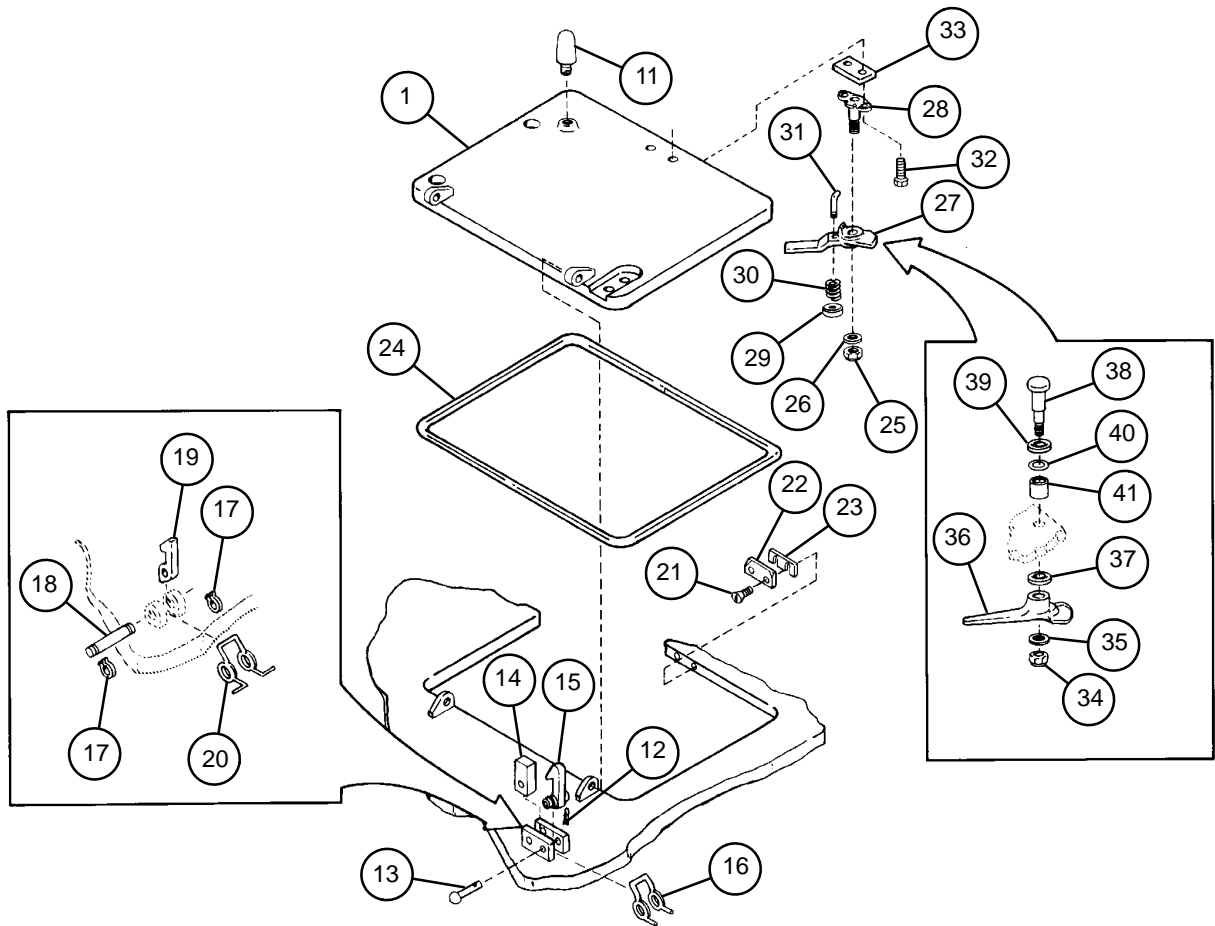
Adhesives can burn easily, can give off harmful vapors, and are harmful to skin and clothing. To avoid injury or death, keep away from open fire and use in well-ventilated area. If adhesive gets on skin or clothing, wash immediately with soap and water.

- 5 Apply adhesive to new seal (24) and install on gunner's escape hatch (1).
- 6 Using two cap screws (21), install plate spacer(s) (22 and 23) inside roof of cab.

**NOTE**

Depending on which configuration of gunner's escape hatch is being assembled, perform either step 7 or 8.

- 7 Install torsion helical spring (20) and pawl (19) on cab roof using headless grooved pin (18) and two new retaining rings (17).
- 8 Install torsion helical spring (16), pawl (15), and bumper (14) on cab roof using two headed straight pins (13) and two new cotter pins (12).
- 9 If present, install bumper (11) on gunner's escape hatch (1).



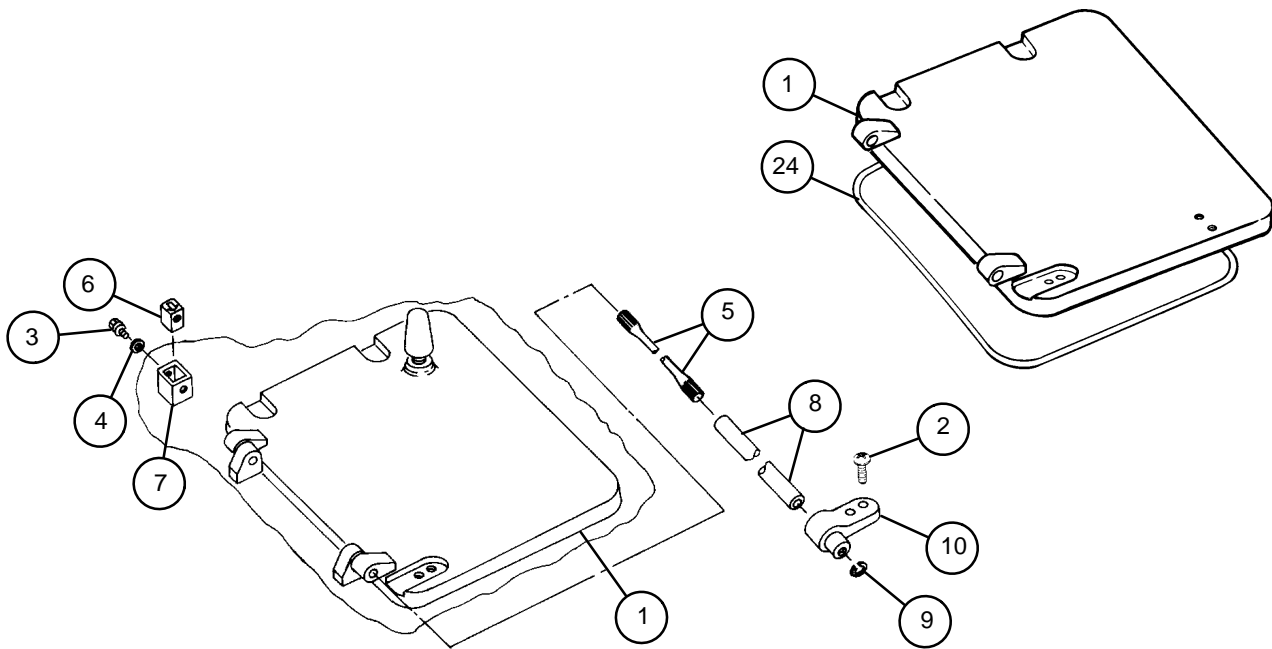
**14-1 GUNNER'S ESCAPE HATCH (UNMODIFIED) — CONTINUED**

**d. Installation**

**NOTE**

Immediately prior to installation, apply primer to all contact surfaces, except threaded ones, as shown in illustration.

- 1 Place gunner's escape hatch (1) on new seal (24) in cab roof.
- 2 Place torsion bar anchor (6) in retainer weldment (7), if it has been removed.
- 3 Install retaining plate (10) and new retaining ring (9) on one end of torsion bar (5).
- 4 Install tube (8) over torsion bar (5) and then insert as an assembly through hinges of gunner's escape hatch (1) and roof, but do not engage splines on end of torsion bar with torsion bar anchor (6).
- 5 Install two machine screws (2) to fasten retaining plate (10) to gunner's escape hatch (1).
- 6 Apply sealing compound (item 27, Appx D) to plug (3). Install flat washer (4) and plug. Torque plug to 50 lb-ft (37 N·m).





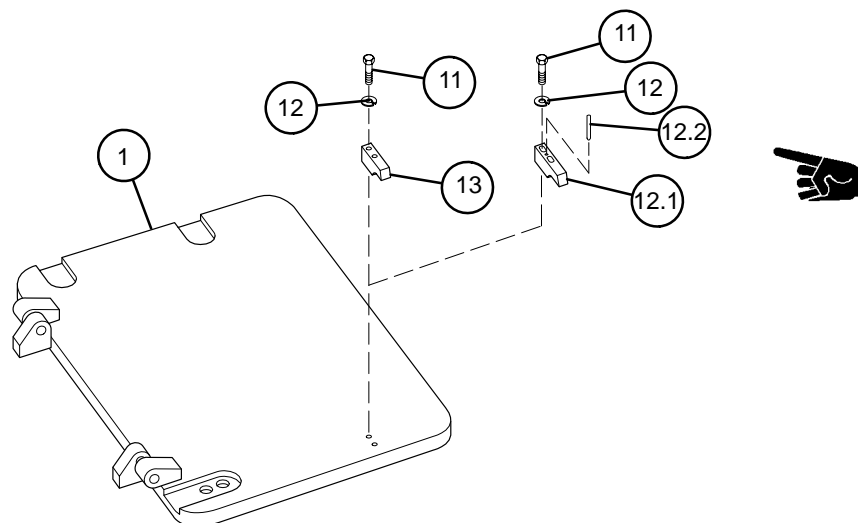
## 14-2 GUNNER'S ESCAPE HATCH (MODIFIED) — CONTINUED

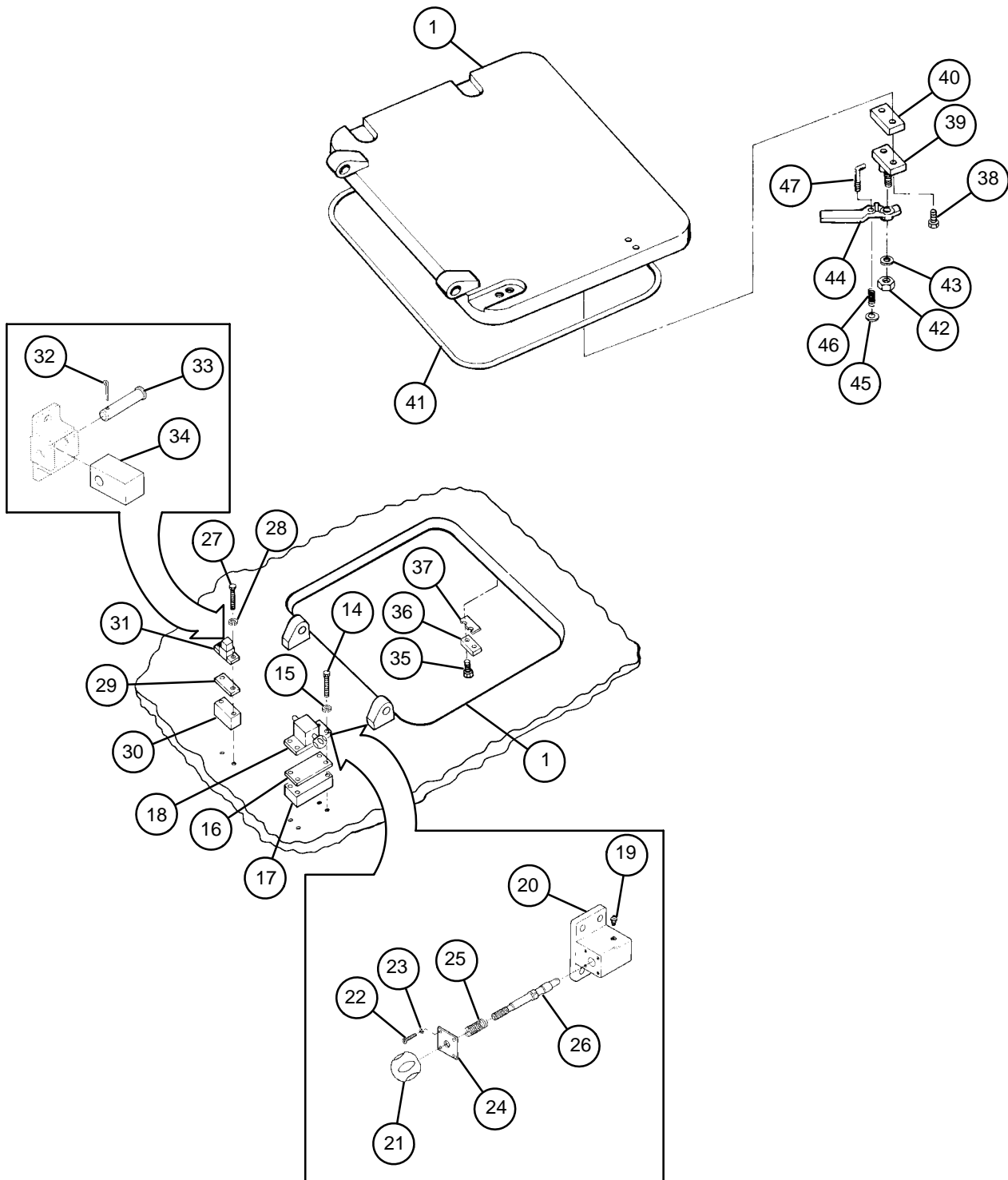
### b. Disassembly

#### NOTE

Step 1 applies only to vehicles with slotted catch strike.

- 1 Remove two cap screws (11), two lockwashers (12), slotted catch strike (12.1) and pin (12.2). Discard pin and lockwashers.
- 2 Remove two cap screws (11), two lockwashers (12), and catch strike (13). Discard lockwashers.
- 3 Remove four cap screws (14), four lockwashers (15), shim(s) (16), latch block (17), and latch assembly (18). Discard lockwashers and shims.
- 4 Disassemble latch assembly (18) if necessary:
  - (a) Remove lubrication fitting (19) from latch body (20) and remove knob (21).
  - (b) Remove four machine screws (22), four lockwashers (23), access cover (24), compression helical spring (25), and headless shoulder pin (26), from latch body (20). Discard lockwashers.
- 5 Remove two cap screws (27), two lockwashers (28), shim(s) (29), bumper block (30), and bumper assembly (31). Discard lockwashers and shims.
- 6 Disassemble bumper assembly (31), if necessary, by removing cotter pin (32), headed straight pin (33), and bumper (34). Discard cotter pin.
- 7 Remove two cap screws (35), plate spacer (36), and plate spacer(s) (37) from inside roof of cab.
- 8 Remove two cap screws (38), joining door handle mounting (39) to plate spacer (40).
- 9 Remove and discard seal (41) from gunner's escape hatch (1).
- 10 Remove self-locking nut (42), flat washer (43), and door handle (44) from door handle mounting (39). Discard self-locking nut.
- 11 Remove knob (45), compression helical spring (46), and threaded straight pin (47) from door handle (44).





---

## 14–2 GUNNER’S ESCAPE HATCH (MODIFIED) — CONTINUED

---

### c. Assembly

<b>WARNING</b>
----------------

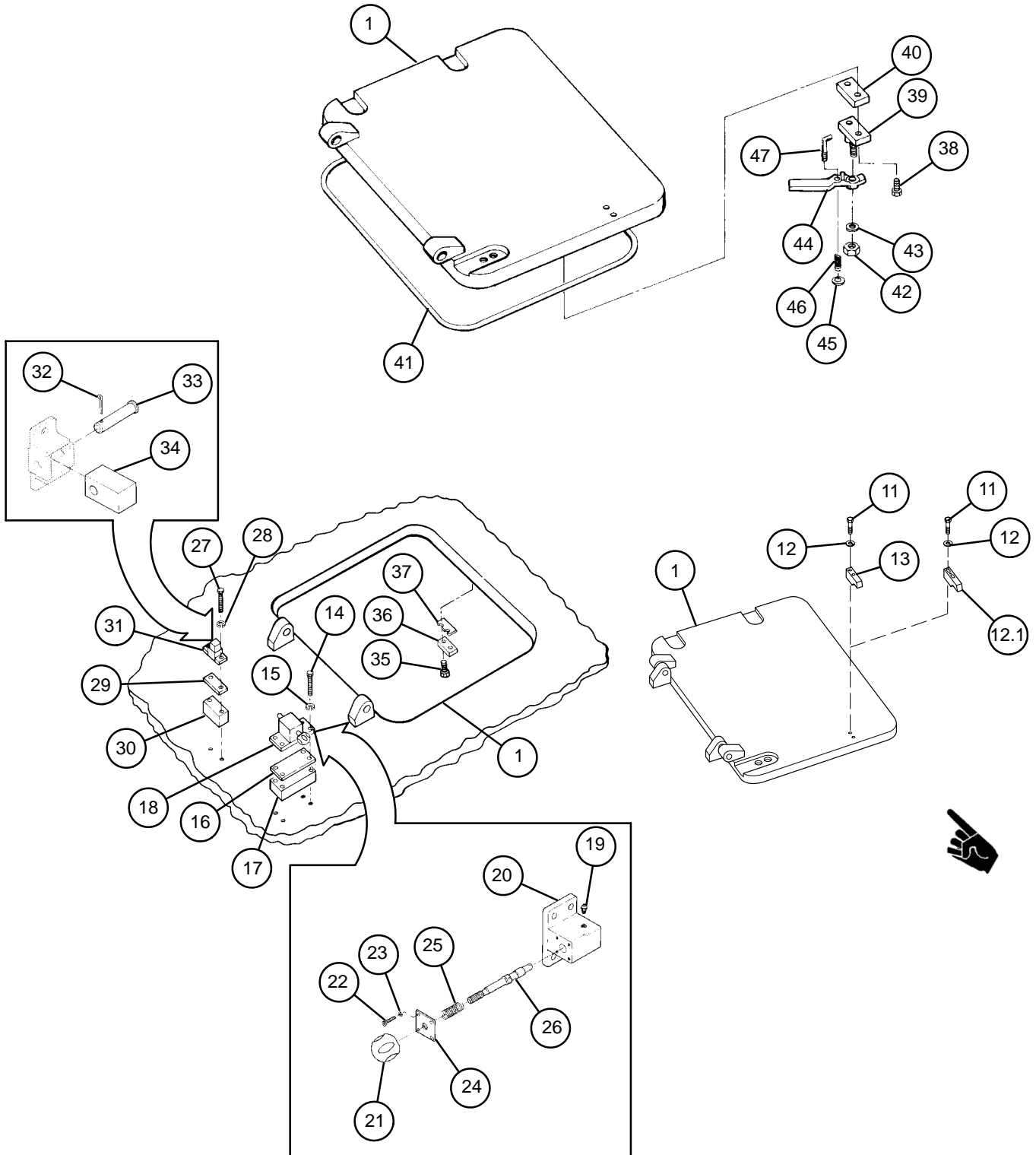
Adhesives can burn easily, can give off harmful vapors, and are harmful to skin and clothing. To avoid injury or death, keep away from open fire and use in well-ventilated area. If adhesive gets on skin or clothing, wash immediately with soap and water.

- 1 Apply adhesive to recess on gunner’s escape hatch (1).
- 2 Apply sealing compound, (item 30, Appx D), to threads of threaded straight pin (47). Attach compression helical spring (46) and knob (45) to door handle (44) using threaded straight pin (47).
- 3 Install door handle (44), flat washer (43), and new self-locking nut (42) on door handle mounting.
- 4 Apply adhesive to new seal (41) and install on gunner’s escape hatch (1).
- 5 Install two cap screws (38) to join plate spacer (40) to door handle mounting (39). Add or subtract plate spacers (40), as necessary, for secure fit of door handle (44) on door handle mounting (39).
- 6 Using two cap screws (35), install plate spacer (36), and plate spacer(s) (37) inside roof of cab.
- 7 Install catch strike (13) using two new lockwashers (12) and two cap screws (11).

### NOTE

Step 7.1 applies to vehicles with slotted catch strike.

- 7.1 Install slotted catch strike (12.1) using two new lockwashers (12) and two cap screws (11).
- 8 Reassemble bumper assembly (31) by installing bumper (34), headed straight pin (33), and new cotter pin (32).
- 9 Reassemble latch assembly (18):
  - (a) Install headless shoulder pin (26) and compression helical spring (25) in latch body (20).
  - (b) Apply sealing compound (item 30, Appx D) to threads of four machine screws (22). Install access cover (24), four new lockwashers (23), and four machine screws (22).
  - (c) Apply sealing compound (item 30, Appx D) to threads of knob (21) and install.
  - (d) Pack latch body (20) with grease through lubrication fitting hole and install lubrication fitting (19).
- 10 Install bumper block (30), new shims (29), equal to disassembly, and bumper assembly (31) using two new lockwashers (28), and two cap screws (27).
- 11 Install latch assembly (18), latch block (17), and new shim(s) (16), equal to disassembly, using four new lockwashers (15) and four cap screws (14).



---

## 14-2 GUNNER'S ESCAPE HATCH (MODIFIED) — CONTINUED

---

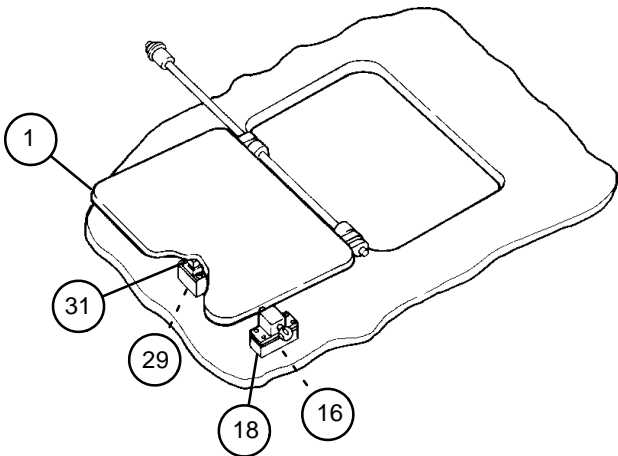
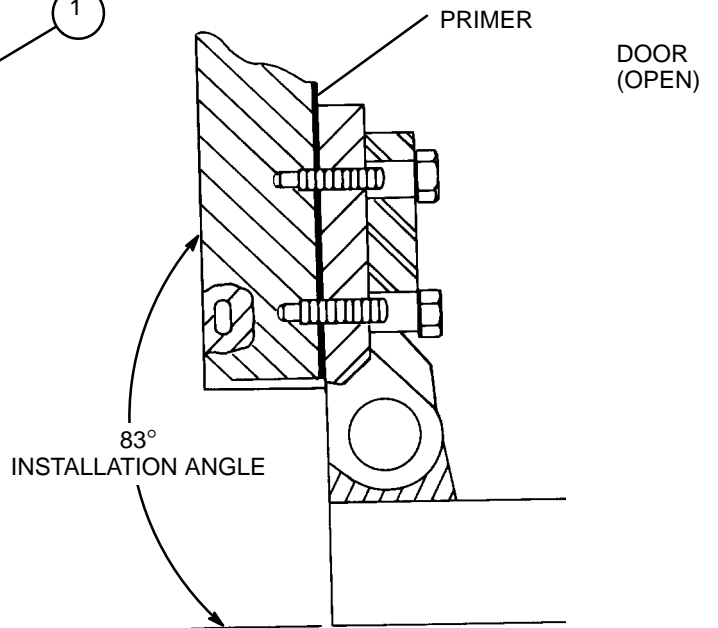
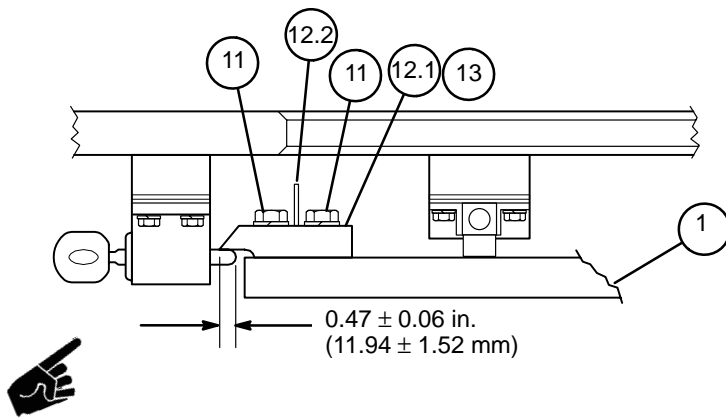
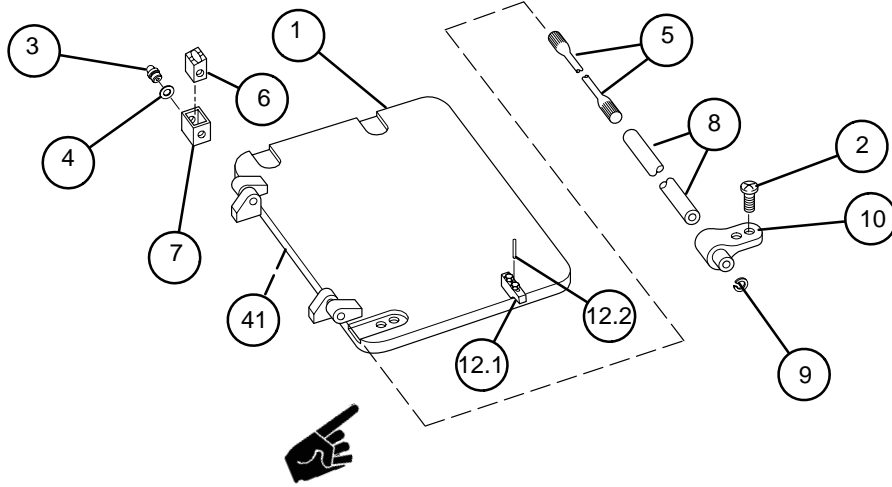
### d. Installation

#### NOTE

Immediately prior to installation, apply primer to all contact surfaces, except threaded ones, as shown in illustration.

- 1 Place gunner's escape hatch (1) with new seal (41) in cab roof.
- 2 Place torsion bar anchor (6) in retainer weldment (7), if it has been removed.
- 3 Install retaining plate (10) and new retaining ring (9) on one end of torsion bar (5).
- 4 Install tube (8) over torsion bar (5) and then insert as an assembly through hinges of gunner's escape hatch (1) and roof, but do not engage splines on end of torsion bar with torsion bar anchor (6).
- 5 Install two machine screws (2) to fasten retaining plate (10) to gunner's escape hatch (1).
- 6 Raise gunner's escape hatch (1) to approximately 83° from the horizontal (closed) position (refer to illustration) and engage torsion bar splines with internal splines of torsion bar anchor (6). It is better to engage the torsion bar (5) at less than 83°, rather than more, if an exact installation is not possible. (A change of one spline equals approximately 28°.)
- 7 Apply sealing compound (item 30, Appx D) to plug (3). Install flat washer (4) and plug. Torque plug to 50 lb-ft (37 N·m).
- 7.1 Open gunner's escape hatch (1) ensuring latch assembly (18) is engaged. Measure overlap of headless shoulder pin (26) on the catch strike (13) or slotted catch strike (12.1). Measurement should be  $0.47 \pm 0.06$  in. ( $11.94 \pm 1.52$  mm), if this measurement is not achieved, replace catch strike (13) with slotted catch strike (12.1) or perform Step 7.2 to adjust slotted catch strike.
- 7.2 Remove pin (12.2) from a new slotted catch strike (12.1) if installed. Loosen two cap screws (11) and adjust slotted catch strike until measurement of  $0.47 \pm 0.06$  in. ( $11.94 \pm 1.52$  mm) is achieved. Tighten two cap screws. Drill a  $0.125 \pm 0.004$  in. ( $3.18 \pm 0.102$  mm) dia hole  $0.38$  in. ( $9.65$  mm) deep into the gunner's escape hatch (1) using the slotted catch strike as a guide. Reinstall pin or install new pin (12.2) to secure.
- 8 Check that latch assembly (18) firmly secures gunner's escape hatch (1) against bumper assembly (31). Adjust shims (16) of latch assembly and shims (29) of bumper assembly if necessary.
- 9 Close gunner's escape hatch (1) to check seal integrity and operation of latch.





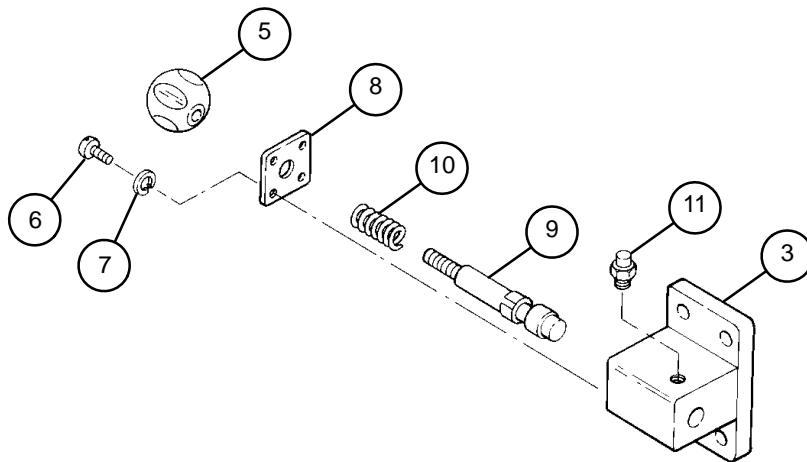


**c. Assembly**

- 1 Install lubrication fitting (11) on side door latch assembly (3).
- 2 Install compression helical spring (10) on latch headless shoulder pin (9). Apply sealing compound to threads of latch headless shoulder pin (9).
- 3 Install latch headless shoulder pin (9) on side door latch assembly (3).
- 4 Install access cover (8) on side door latch assembly (3) using four machine screws (6) and four new lockwashers (7).
- 5 Install knob (5) on headless shoulder latch pin (9).

**d. Installation**

- 1 Using four cap screws (1) and four new lockwashers (2), install side door latch assembly (3) and new shim(s) (4) on cab left side door.
- 2 Lubricate fitting (11) with GAA.







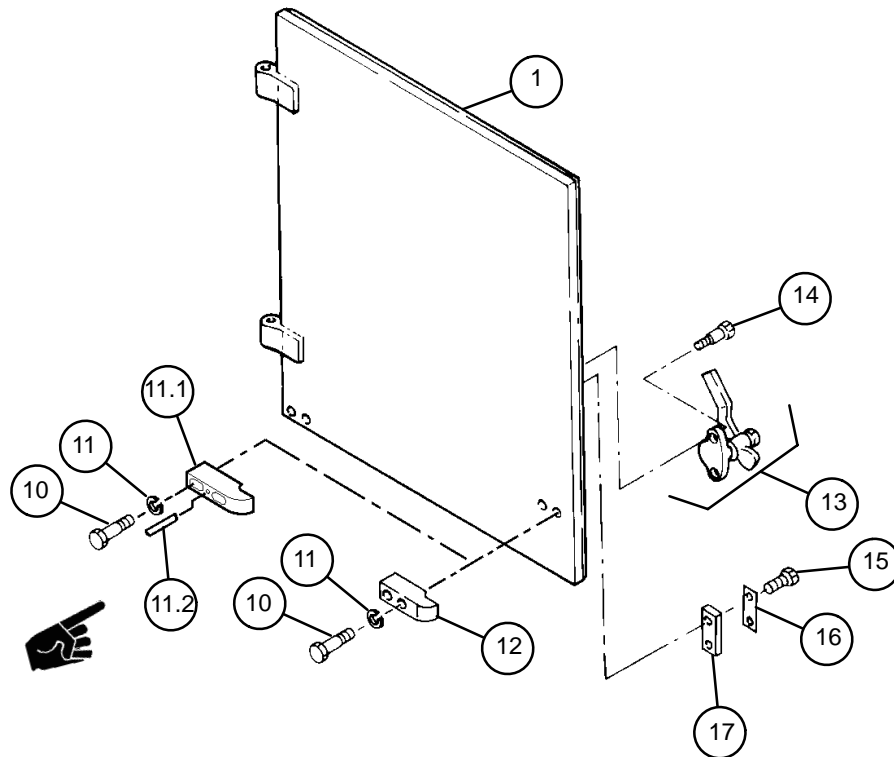
## 14-5 CAB SIDE DOORS, LEFT AND RIGHT — CONTINUED

### b. Disassembly

#### NOTE

Step 1 applies only to vehicles with slotted catch strike.

- 1 Remove two cap screws (10), two lockwashers (11), slotted catch strike (11.1) and pin (11.2). Discard pin and lockwashers.
- 2 Remove two cap screws (10), two lockwashers (11), and catch strike (12) . Discard lockwashers.
- 3 Remove handle assembly (13) from left cab side door (1) by removing two cap screws (14).
- 4 Remove two cap screws (15), plate spacer(s) (16), and plate spacer (17).
- 5 Remove self-locking nut (18), flat washer (19), and door handle (20) from door mounting handle (21). Discard self-locking nut.
- 6 Remove knob (22) from threaded straight pin (23). This will release compression helical spring (24).
- 7 Remove and discard seal (25) and strip (25.1). Clean dirt and old adhesive from seal seat.
- 8 Remove two cap screws (26).



## c. Assembly

**WARNING**

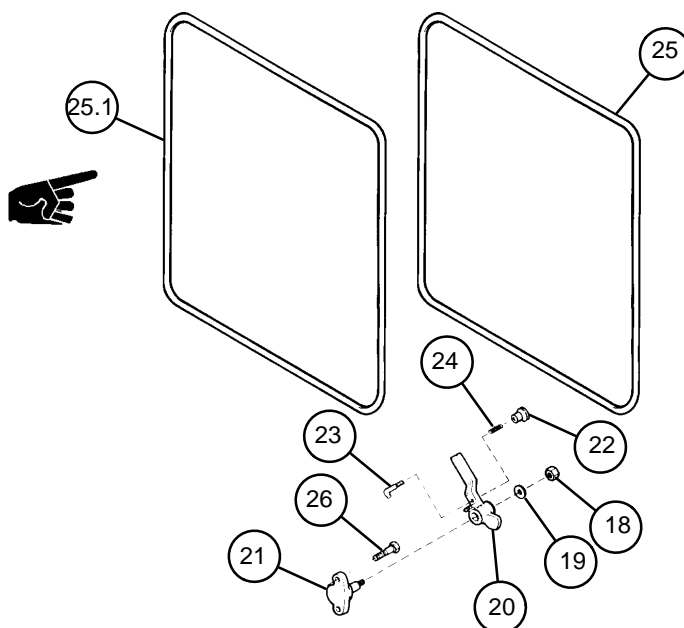
Adhesives can burn easily, can give off harmful vapors, and are harmful to skin and clothing. To avoid injury or death, keep away from open fire and use in well-ventilated area. If adhesive gets on skin or clothing, wash immediately with soap and water.

- 1 Apply adhesive to new strip (25.1) and to seal seat on left cab side door (1). Install strip on left cab side door.
- 2 Apply adhesive to new seal (25) and to strip (25.1) on left cab side door (1). Install seal to strip on left cab side door.
- 3 Apply sealing compound to threads of knob (22). Install knob, compression helical spring (24), and threaded straight pin (23) on door handle (20).
- 4 Install door mounting handle (21) using two cap screws (26).
- 5 Install door handle (20) on door mounting handle (21) using flat washer (19) and new self-locking nut (18).
- 6 Install new plate spacer(s) (16), as needed, and plate spacer (17) on left side door using two cap screws (15).
- 7 Apply zinc chromate paste to left cab side door (1) where door mounting handle (21) was removed and to all aluminum-to-steel contacts.
- 8 Install handle assembly (13) inside left cab side door (1) using two cap screws (14).
- 9 Install catch strike (12) on outside of left cab side door (1) using two cap screws (10) and two new lock-washers (11).

**NOTE**

Step 10 applies to vehicles with slotted catch strike.

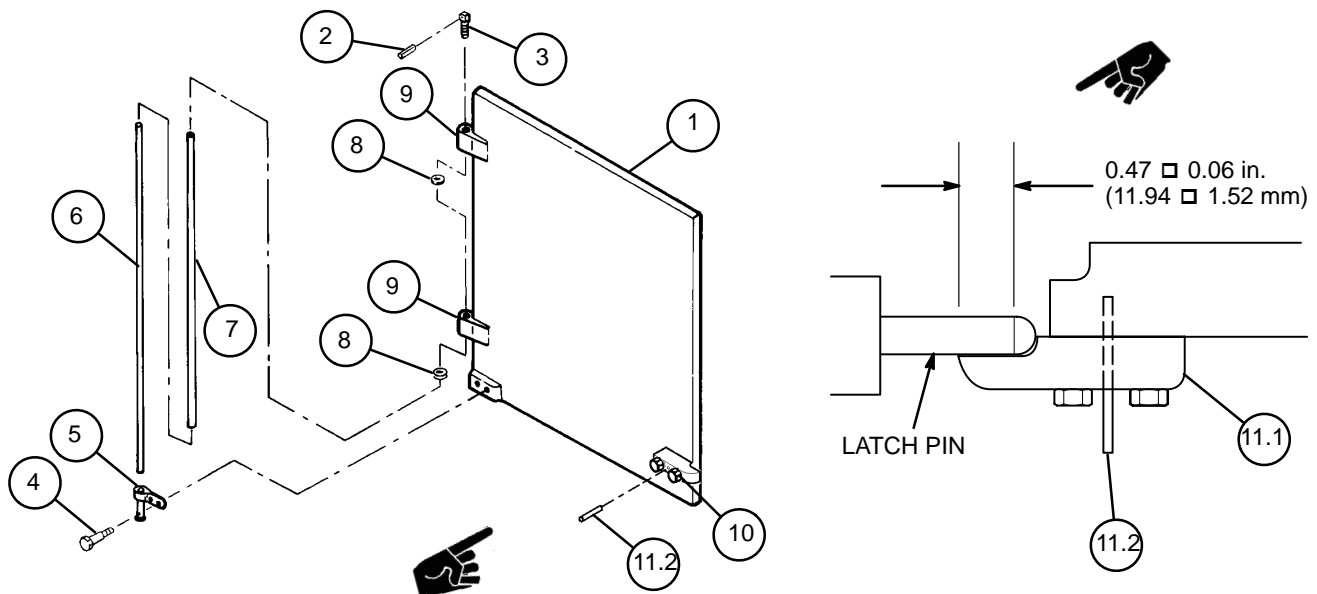
- 10 Install slotted catch strike (11.1) on outside of left cab side door (1), using two cap screws (10) and two new lockwashers (11).



## 14-5 CAB SIDE DOORS, LEFT AND RIGHT — CONTINUED

### d. Installation

- 1 Install torsion bar anchor (3) into cab. Be sure holes for spring pin (2) are horizontal.
- 2 Place left cab side door (1) over seal in door opening, alining holes in hinges (9), and support door assembly in this position.
- 3 Install flat washers (8), as required, torsion bar (6), and tube (7) in hinges (9) of left cab side door (1). Align the hole in torsion bar with the hole for spring pin (2) in torsion bar anchor (3).
- 4 Install new spring pin (2) to retain torsion bar (6) in torsion bar anchor (3).
- 5 Open left cab side door (1) to 90° and support in this position.
- 6 Install torsion bar bracket (5) by alining with splines of torsion bar (6) and fasten to left cab side door (1) ensuring left cab side door is perpendicular to the cab.
- 7 Install torsion bar bracket (5) to left cab side door (1) with two cap screws (4).
- 7.1 Open left cab side door (1) ensuring latch is engaged. Measure over lap of latch pin on the catch strike. It should be  $0.47 \pm 0.06$  in. ( $11.94 \pm 1.52$  mm), if this measurement is not achieved, replace catch strike (12) with slotted catch strike (11.1) or perform Step 7.2 to adjust slotted catch strike.
- 7.2 Remove pin (11.2) from new slotted catch strike (11.1) if installed. Loosen cap screws (10) and adjust slotted catch strike until measurement of  $0.47 \pm 0.06$  in. ( $11.94 \pm 1.52$  mm) is achieved. Tighten cap screws (10). Drill a hole  $0.125 \pm 0.004$  in. ( $3.18 + 0.102$  mm) deep into the cab side door (1) using slotted catch strike as a guide. Reinstall pin or install new pin (11.2) to secure.
- 8 Close left cab side door (1). When latch is released, the left cab side door (1) will spring open gently if properly installed.





## 14-6 CAB BUSTLE DOOR GROUP (STRIKE AND BRACKET ASSEMBLIES)

This task covers: a. Removal b. Installation

### INITIAL SETUP

#### Tools

Artillery and turret mechanic's tool kit  
(SC 5180-95-CL-A12)

#### Materials/Parts

Cotter pins (2) (item 38, Appx G)  
Lockwashers (8) (item 81, Appx G)

Lockwashers (6) (item 83, Appx G)

Shims (V) (item 163, Appx G)

Shims (V) (item 164, Appx G)

Shims (V) (item 165, Appx G)

#### Personnel Required

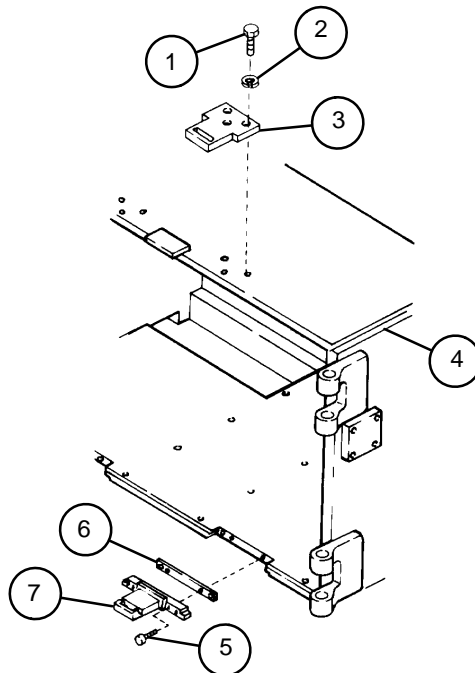
2

### a. Removal

#### NOTE

- Inspect inserts in screw and bolt holes. If threads are stripped or damaged, replace inserts.
- Bustle doors must be open or removed (para 14-8), for removal of strike assemblies.

- 1 Remove six cap screws (1), six lockwashers (2), and two strike assemblies (3) from top of bustle door assemblies (left and right) (4). Discard lockwashers.
- 2 Remove four cap screws (5), shim(s) (6) (if used), and two strike assemblies (7) from bottom of bustle door assemblies (left and right) (4). Discard shims.



## 14-6 CAB BUSTLE DOOR GROUP (STRIKE AND BRACKET ASSEMBLIES) — CONTINUED

### a. Removal — Continued

#### NOTE

Bustle doors must be closed or removed for removal of bracket assemblies.

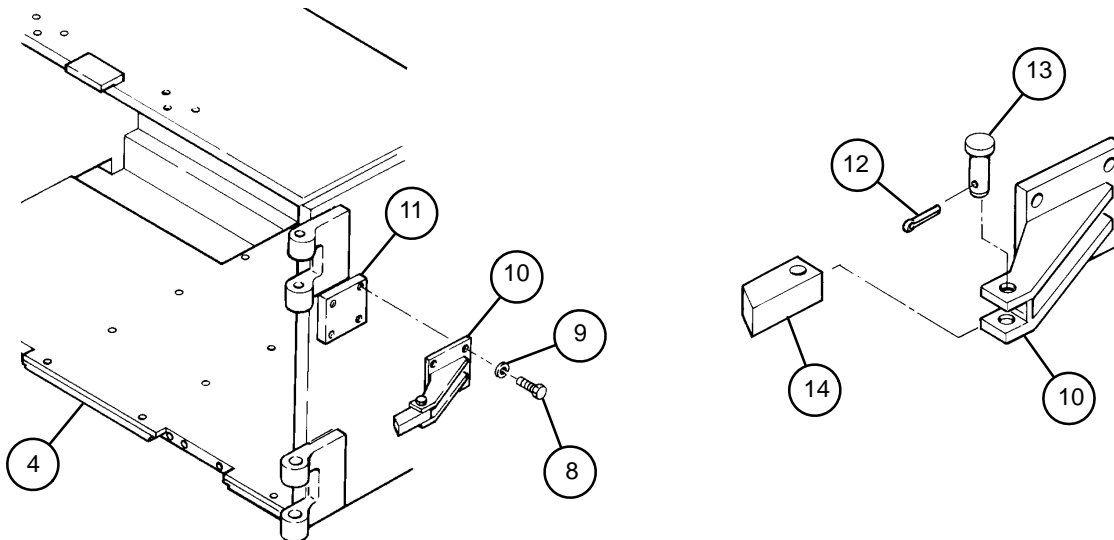
- 3 Remove eight cap screws (8), eight lockwashers (9) and two bracket assemblies (10) from mounting pads (11) on bustle door assemblies (left and right) (4). Discard lockwashers.
- 4 Remove cotter pin (12), headed straight pin (13), and bumper (14) from each of the two bracket assemblies (10). Discard cotter pin.

### b. Installation

#### NOTE

Bustle doors must be closed, unless removed (para 14-8), for installation of bracket assemblies.

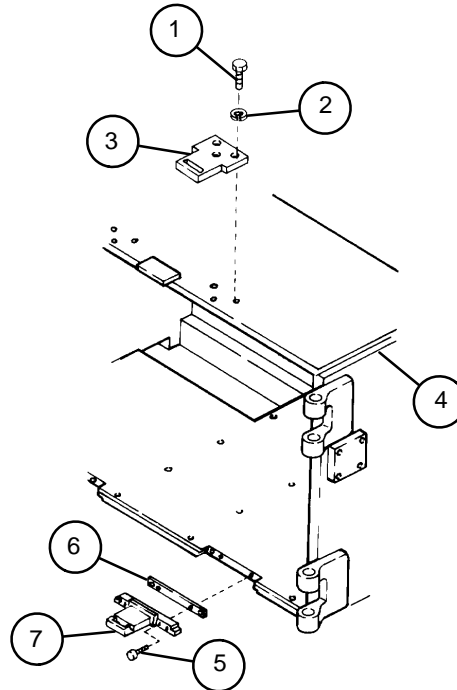
- 1 Install bumper (14), headed straight pin (13), and new cotter pin (12) on each of two bracket assemblies (10).
- 2 Install two bracket assemblies (10) on mounting pads (11) of bustle door assemblies (left and right) (4), using eight cap screws (8) and eight new lockwashers (9).



**NOTE**

Bustle doors must be open, unless removed, for installation of strike assemblies.

- 3 Aline screw holes on two bottom strike assemblies (7) with screw holes on bottom of bustle door assemblies (left and right) (4). Install new shim(s) (6) (if required) and two strike assemblies (7), using eight socket head cap screws (5).
- 4 Aline screw holes on two top strike assemblies (3) with screw holes on top of bustle door assemblies (left and right) (4). Install two top strike assemblies using six new lockwashers (2) and six cap screws (1).





**b. Disassembly**

- 1 Remove seal (9) from projectile access door (4) and discard.
- 2 Remove seal (10) and strip (10.1) from projectile access door (4) and discard.
- 3 Clean seal seats to remove dirt and old adhesive.

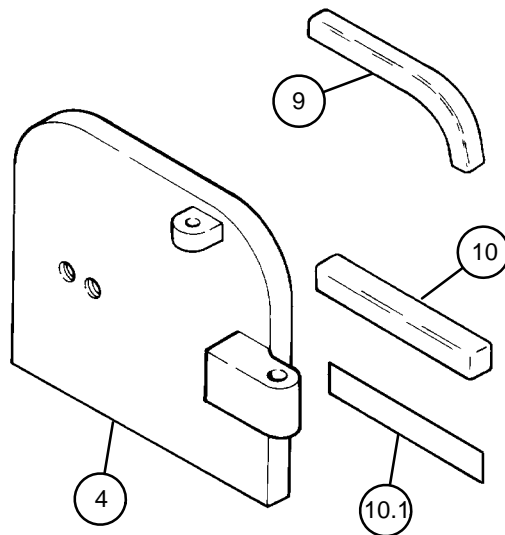
**c. Assembly****WARNING**

Adhesives can burn easily, can give off harmful vapors, and are harmful to skin and clothing. To avoid injury or death, keep away from open fire and use in well-ventilated area. If adhesive gets on skin or clothing, wash immediately with soap and water.

- 1 Apply adhesive to cleaned seal seats and to new strip (10.1).
- 1.1 Install new strip (10.1) on projectile access door (4).
- 1.2 Apply adhesive to new seals (9 and 10).
- 2 Install new seals (9 and 10) on projectile access door (4).

**d. Installation**

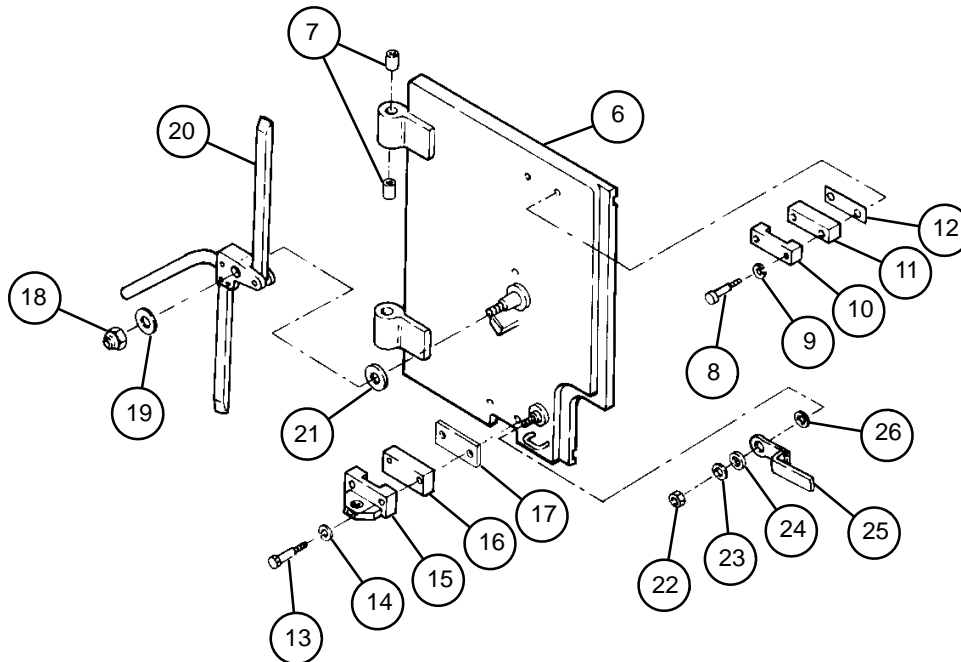
- 1 Install thrust washer bearing (8).
- 2 Install projectile access door (4) at the bottom of the bustle door assembly.
- 3 Install cap screw (6), two flat washers (7), and new self-locking nut (5) on projectile access door (4).
- 4 Install new shim(s) (3), as required, and catch strike (2) on projectile access door (4), using two cap screws (1).





## b. Disassembly

- 1 Remove four sleeve bearings (7) from left bustle door (6) and discard.
- 2 Remove two cap screws (8), two lockwashers (9), locking bar slide (10), plate spacer (11), and shim(s) (12) from left bustle door (6). Discard lockwashers and shims.
- 3 Remove two cap screws (13), two lockwashers (14), catch strike (15), wear plate (16), and shim(s) (17) from left bustle door (6). Discard lockwashers and shims.
- 4 Remove self-locking nut (18), thrust washer bearing (19), clevis assembly (20), and thrust washer bearing (21) from left bustle door (6). Discard self-locking nut.
- 5 Repeat steps 1 through 4 for right bustle door (4).
- 6 Remove self-locking nut (22), flat washer (23), flat washer (24), rim latch (25), and flat washer (26) from left bustle door (6) only. Discard self-locking nut.



---

**14-8 BUSTLE DOOR ASSEMBLIES, LEFT AND RIGHT — CONTINUED**

---

**b. Disassembly — Continued****NOTE**

Clean dirt and old adhesive from seal seats and from areas where pads are removed.

- 7 Remove seal (27), strip (27.1), rubber strip (28), seal (29), and cushioning pad (30), from left bustle door (6). Discard seals, rubber strip, strip and cushioning pad.
- 8 Remove seal (31), strip (31.1), rubber strip (32), rubber strip (33), seal (34), and cushioning pad (35) from right bustle door (4). Discard seals, rubber strip, strip and cushioning pad.

**c. Assembly**

**WARNING**

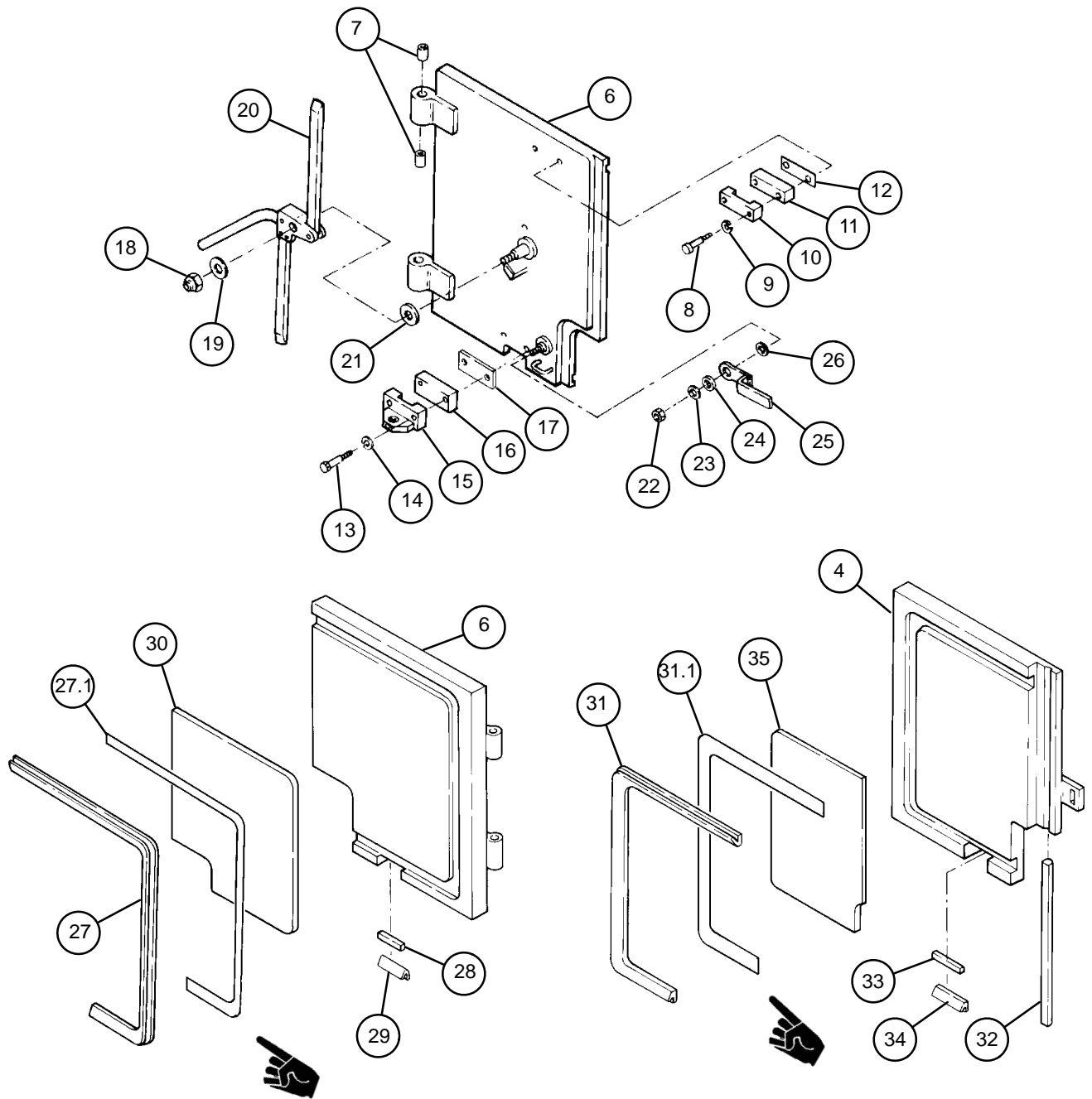
Adhesives can burn easily, can give off harmful vapors, and are harmful to skin and clothing. To avoid injury or death, keep away from open fire and use in well-ventilated area. If adhesive gets on skin or clothing, wash immediately with soap and water.

**NOTE**

- Apply zinc chromate paste between contact surfaces of aluminum and steel.
- Apply adhesive to rubber strips, seals, cushioning pads, and cleaned door surfaces where seals and pads are to be installed.

- 1 Install new seal (27), new strip (27.1), new rubber strip (28), new seal (29), and new cushioning pad (30) on left bustle door (6).
- 2 Install new seal (31), new strip (31.1), new rubber strip (32), new rubber strip (33), new seal (34), and new cushioning pad (35) on right bustle door (4).
- 3 Install flat washer (26), latch (25), flat washer (24), flat washer (23), and new self-locking nut (22) on left bustle door (6) only.
- 4 Install clevis assembly (20) on left bustle door (6) using thrust washer bearing (21), thrust washer bearing (19), and new self-locking nut (18).
- 5 Install new shim(s) (17), as required, wear plate (16), and catch strike (15) on left bustle door (6) using two new lockwashers (14) and two cap screws (13).
- 6 Install new shim(s) (12), as required, plate spacer (11), and locking bar slide (10) on left bustle door (6) using two new lockwashers (9) and two cap screws (8).
- 7 Install four new sleeve bearings (7) on left bustle door (6).
- 8 Repeat steps 4 through 7 on right bustle door (4).





---

## 14-8 BUSTLE DOOR ASSEMBLIES, LEFT AND RIGHT — CONTINUED

---

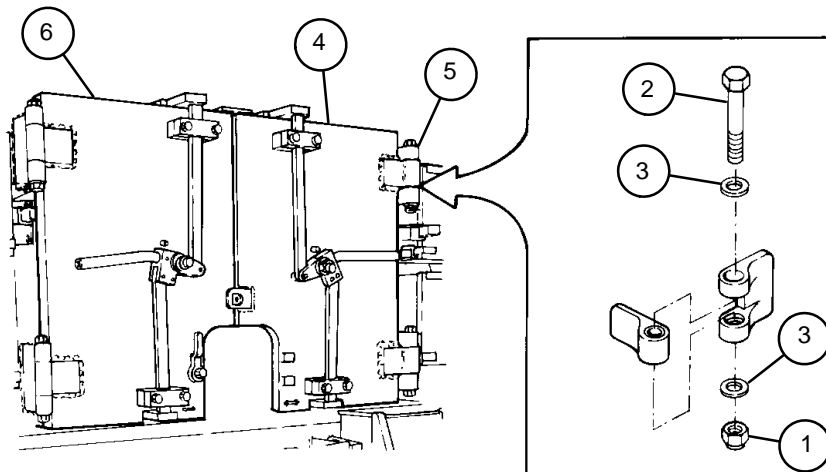
### d. Installation

- 1 Using two personnel, install right bustle door (4) into right side of bustle (5).

#### NOTE

When installing doors on hinges, do not apply full torque to nuts. After nut makes initial contact with washer and hinge, tighten an additional half-turn.

- 2 Install two cap screws (2), four flat washers (3), and two new self-locking nuts (1) on right bustle door (4).
- 3 Repeat steps 1 and 2 for left bustle door (6).
- 4 Close and latch left bustle door (4) and right bustle door (6).



## 14-9 BUSTLE DOOR ARM CLEVIS ASSEMBLY

This task covers: a. Disassembly b. Assembly

### INITIAL SETUP

#### Tools

Artillery and turret mechanic's tool kit  
(SC 5180-95-CL-A12)

#### Materials/Parts

Retaining clips (2) (item 173, Appx G)  
Sealing compound (item 30, Appx D)

Sleeve bearing (item 110.1, Appx G)  
Sleeve bearings (2) (item 109, Appx G)  
Spring pins (2) (item 19, Appx G)  
Spring pin (item 17, Appx G)

#### Equipment Condition

Disassemble bustle door assemblies (para 14-8)

### NOTE

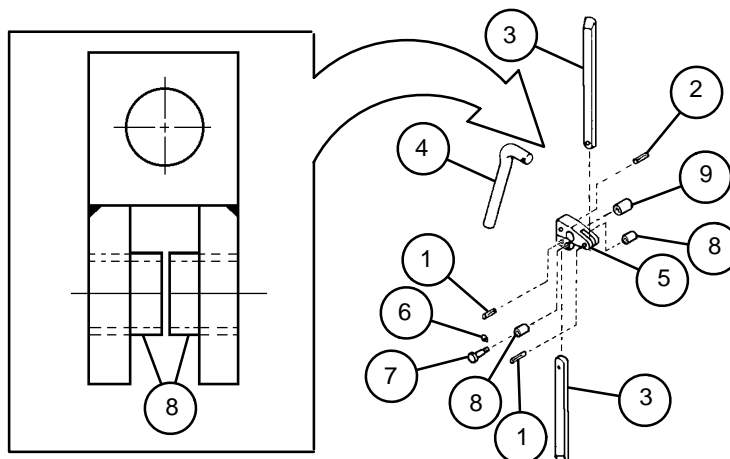
Procedures are written for removing clevis from left bustle door, but also apply to removing clevis from right bustle door.

#### a. Disassembly

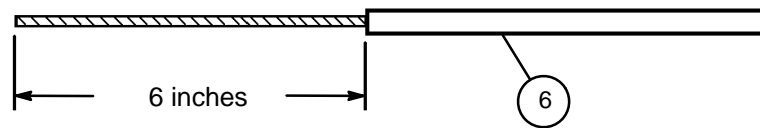
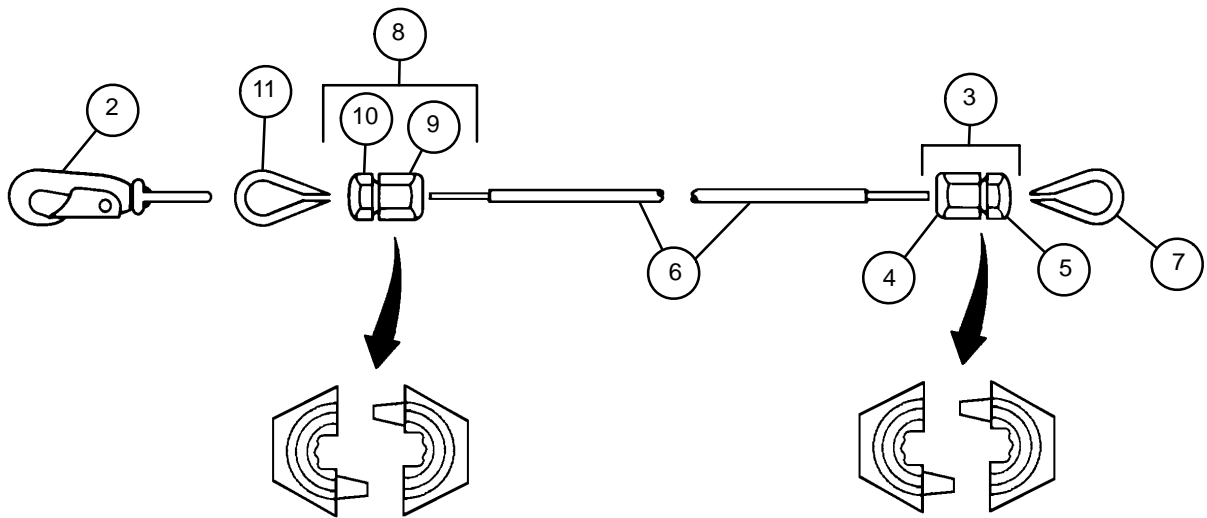
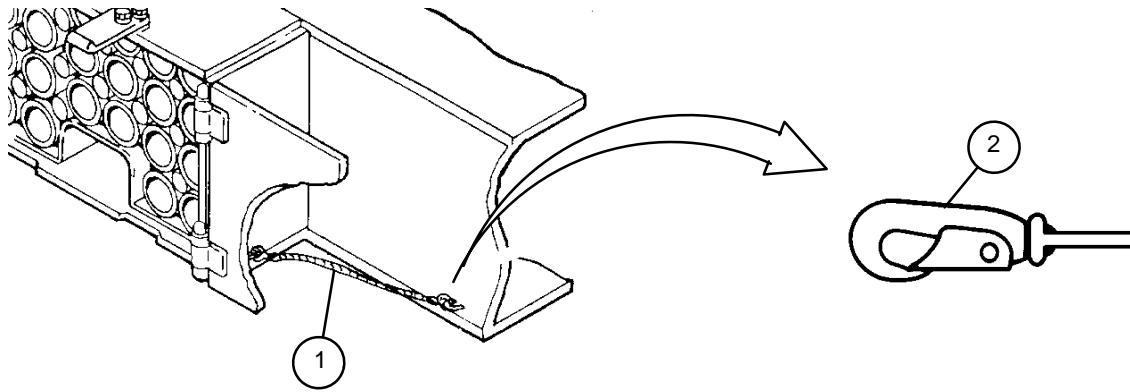
- 1 Remove two spring pins (1), spring pin (2), two locking arms (3), and door handle (4) from clevis (5) on left bustle door. Clevis assembly will now come off. Discard spring pins.
- 2 Remove retaining clip (6) and headed grooved pin (7) from clevis (5). Discard retaining clip.
- 3 Remove two sleeve bearings (8) from clevis (5) and discard.
- 4 Remove sleeve bearing (9) from clevis (5) and discard.

#### b. Assembly

- 1 Install new sleeve bearing (9) on clevis (5).
- 2 Apply sealing compound to two new sleeve bearings (8) and install on clevis (5).
- 3 Install headed grooved pin (7) and new retaining clip (6) on clevis (5).
- 4 Aline holes on clevis (5) with holes in door handle (4) and two locking arms (3), then secure with two new spring pins (1) and new spring pin (2).



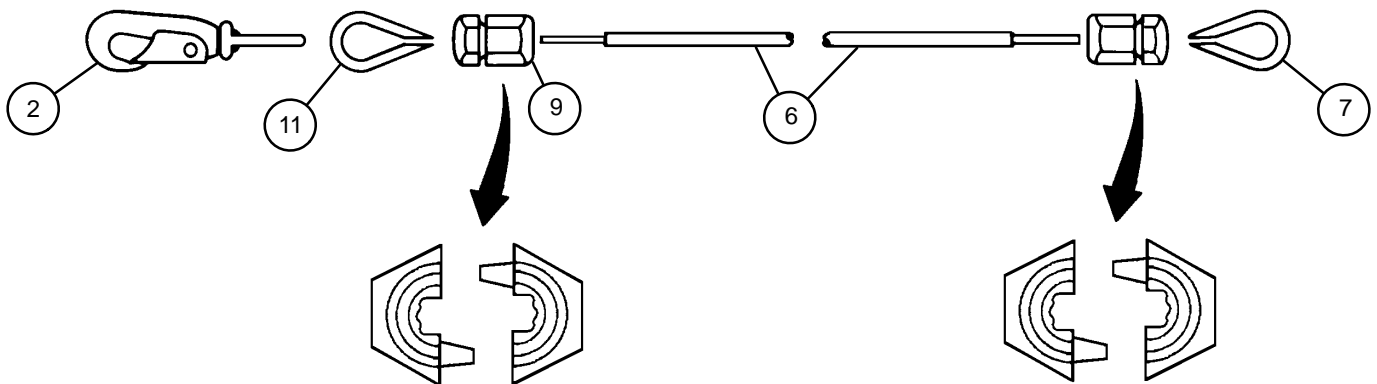
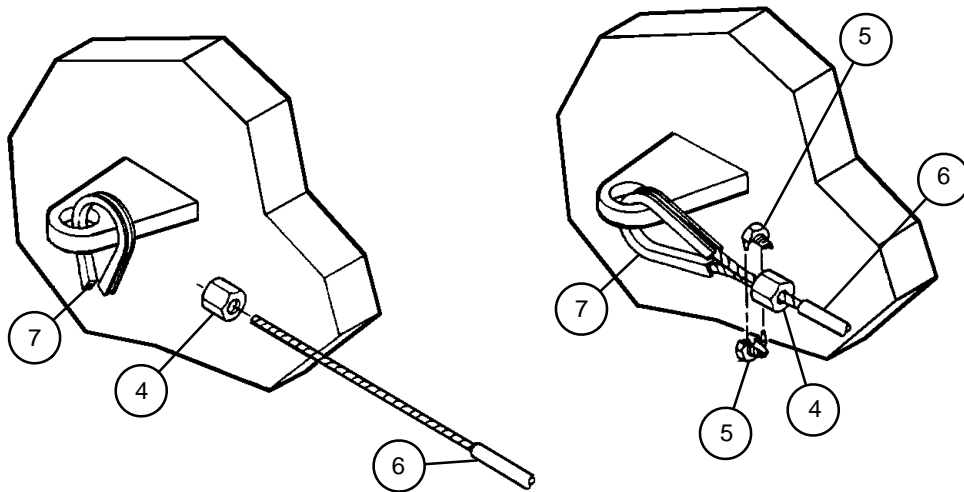




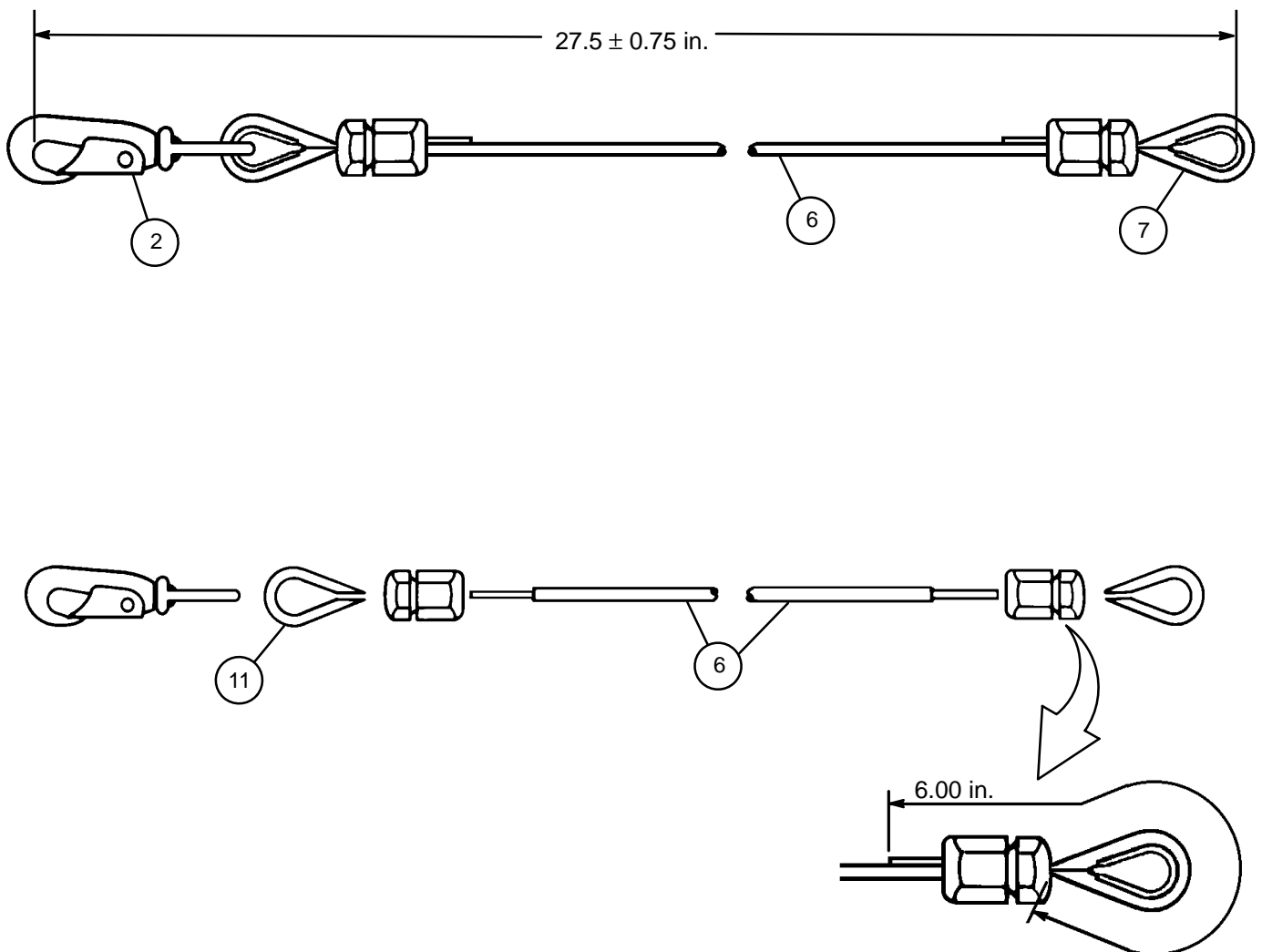
**14-10 BUSTLE DOOR WIRE ROPE ASSEMBLIES, LEFT AND RIGHT – CONTINUED**

**c. Assembly – Continued**

- 2 Slide clamp nut (4) onto wire rope (6).
- 3 Place thimble (7) onto loop fastener on vehicle.
- 4 Insert stripped end of wire rope (6) around thimble (7).
- 5 Place clamp halves (5) around both runs of wire rope at base of thimble (7).
- 6 Slide clamp nut (4) onto clamp halves (5) and tighten, securing the wire rope onto the thimble.
- 7 Install snap hook (2) onto loop fastener on bustle door.
- 8 Place thimble (11) onto snap hook (2).
- 9 Slide clamp nut (9) onto wire rope (6).
- 10 Insert end of wire rope (6) around thimble (11).



- 11 Adjust the length of wire rope (6) between inside of snap hook (2) and inside of thimble (7) to  $27.75 \pm 0.75$  inches ( $704.85 \pm 19.05$  mm).
- 12 Mark where wire rope (6) starts around thimble (7).
- 13 Remove wire rope (6) from thimble (7).
- 14 Measure from mark made in step 12 out approximately 6 inches and cut off excess wire rope.
- 15 Strip cover from mark to end of wire rope (6).
- 16 Reinsert stripped end of wire rope (6) around thimble (11).



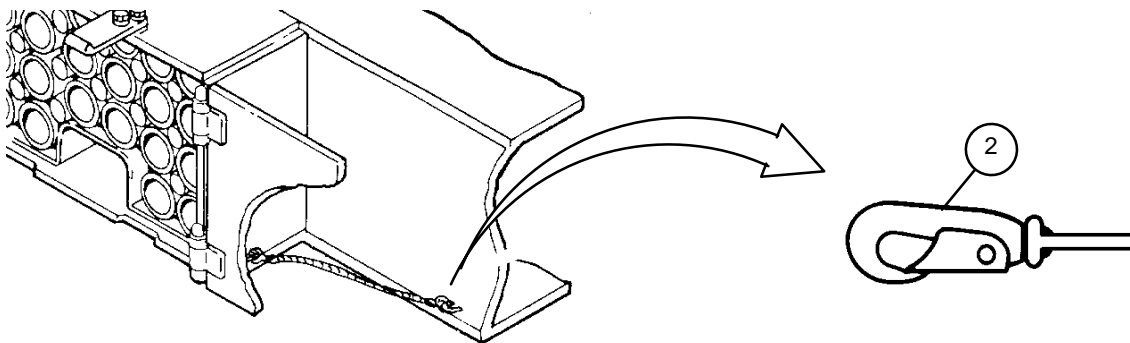
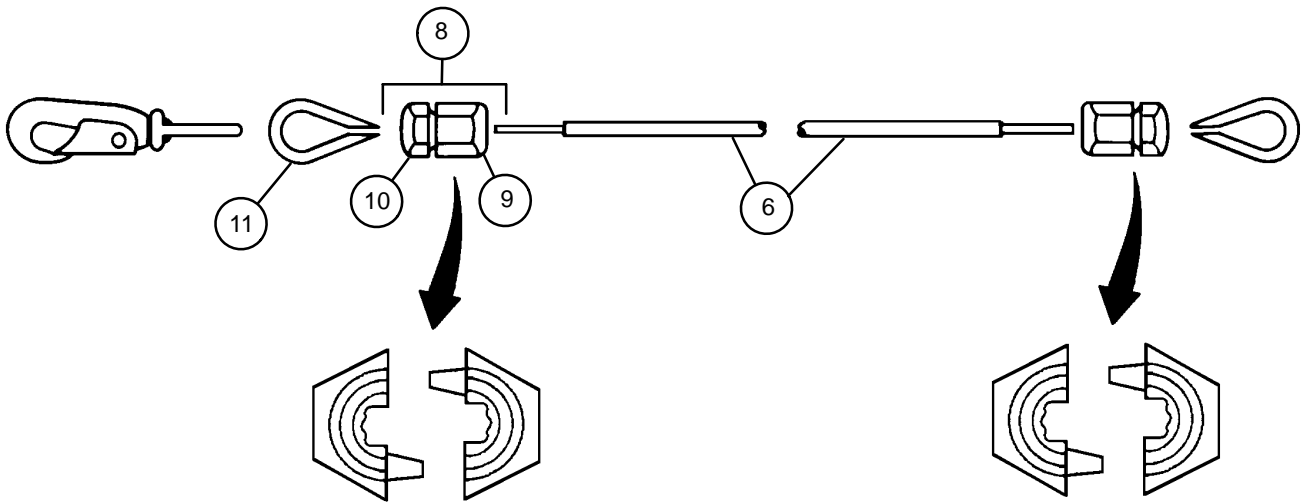
## 14-10 BUSTLE DOOR WIRE ROPE ASSEMBLIES, LEFT AND RIGHT – CONTINUED

### c. Assembly – Continued

- 17 Place clamp halves (10) at base of thimble (11) around both runs of wire rope (6).
- 18 Slide clamp nut (9) onto clamp halves (10) and hand tighten.
- 19 Recheck for proper length.
- 20 Tighten clamp (8) to wire rope assembly onto the thimble (11).

### d. Installation

Install snap hook (2) onto loop fastener on cab.







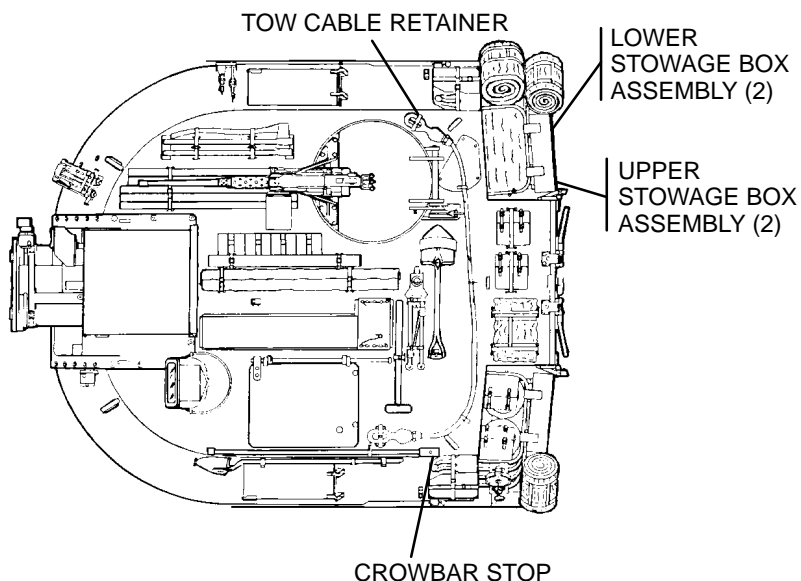


# CHAPTER 15 CAB STOWAGE AND HANDLES

## GENERAL

This chapter illustrates and describes maintenance procedures for the howitzer cab stowage boxes, brackets, supports, and racks.

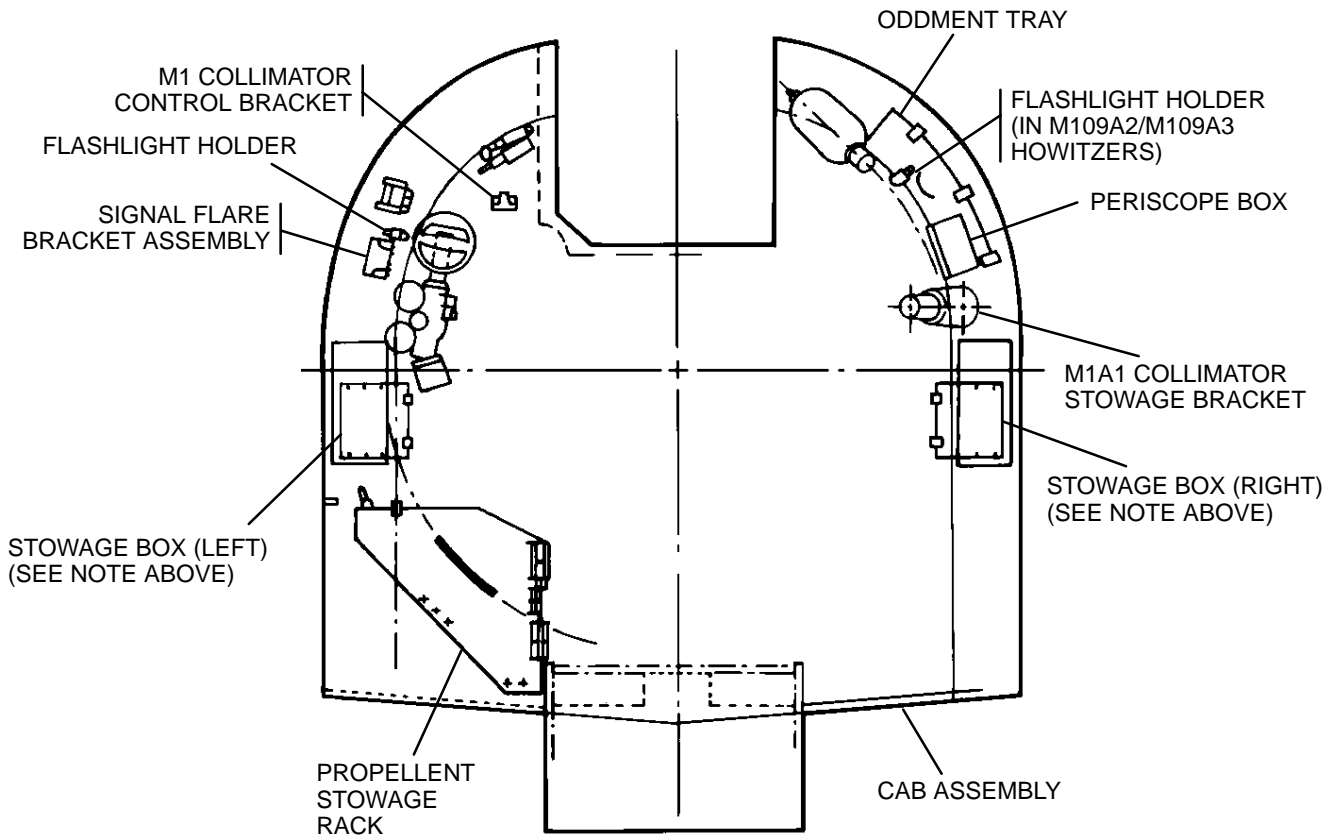
<u>CONTENTS</u>	<u>Page</u>
Section I. CAB AMMO RACK	
15-1     RETAINER ASSEMBLY .....	15-3
Section II. STOWAGE BOXES	
15-2     EXTERIOR STOWAGE BOXES .....	15-6
15-3     M27 PERISCOPE STOWAGE BOX .....	15-10
15-4     ODDMENT STOWAGE BOXES .....	15-12
Section III. STOWAGE BRACKETS	
15-5     COLLIMATOR BRACKET ASSEMBLY AND RACK SUPPORT .....	15-13
15-6     COLLIMATOR CONTROL BRACKET .....	15-14
15-7     FLASHLIGHT HOLDER .....	15-16
15-8     SIGNAL FLARE BRACKET ASSEMBLY .....	15-17
15-9     RIFLE CLIP .....	15-18
15-10    BATTERY COMPUTER SYSTEM MOUNTING BRACKETS .....	15-20
15-11    TOW CABLE RETAINER AND CROWBAR STOP .....	15-22
Section IV. STOWAGE RACKS	
15-12    CANNISTER STOWAGE BRACKET ASSEMBLY .....	15-24
15-13    REAR STOWAGE RACKS .....	15-27
Section V. HANDLES	
15-14    HANDLES .....	15-28



STORAGE BOX (LEFT) CONTENTS
M14 AIMING POST LIGHT FIRST AID KIT PUMP TYPE HAND OILER M14 CHEST M27 FUZE SETTER

ODDMENT BOX CONTENTS
M34 FUZE SETTER M35 FUZE SETTER LANYARD (6 FOOT) VENT CLEANING TOOL

STORAGE BOX (RIGHT) CONTENTS
M8 PRIMER BELT LANYARD (50 FOOT) PAMPHLET BAG EQUIPMENT LOG BOOK OPERATOR'S MANUAL LUBRICATION ORDER TOOLS AND EQUIPMENT FOR CAL. .50 MACHINE GUN





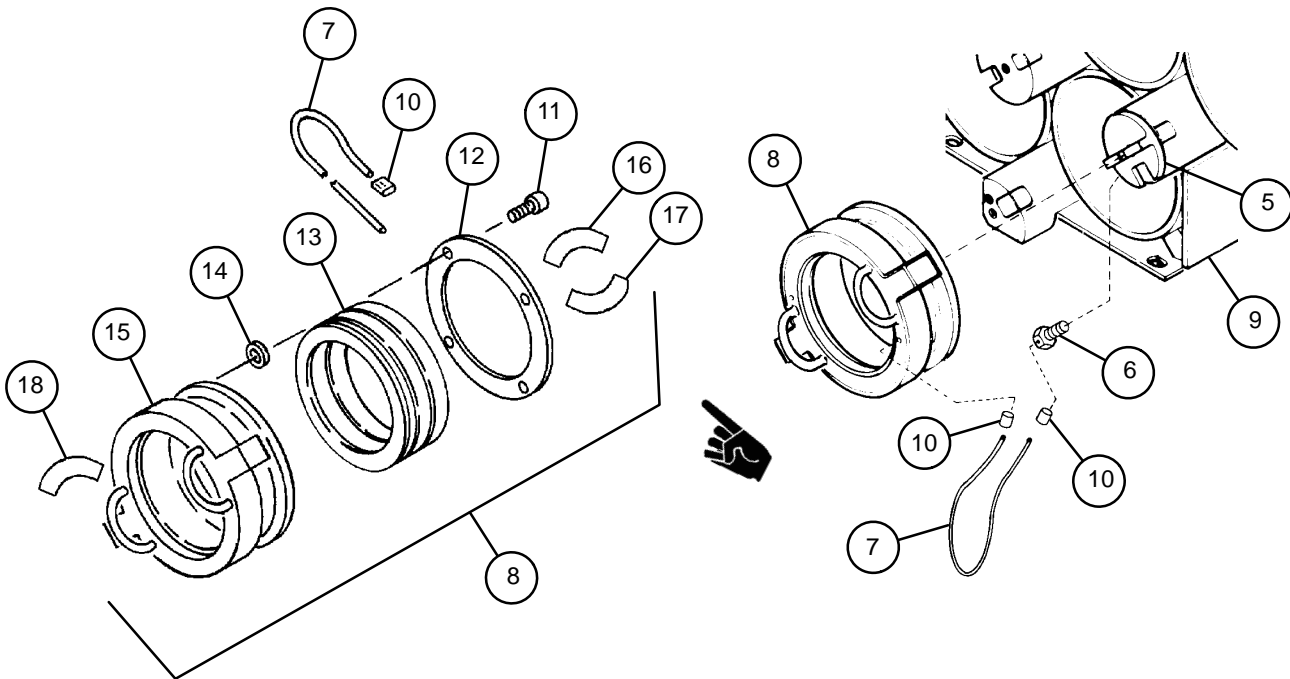
## 15-1 RETAINER ASSEMBLY — CONTINUED

### b. Disassembly

#### NOTE

- Refer to steps 1 through 4 to disassemble retainer assembly PN 11828875.
- Refer to steps 5 through 10 to disassemble retainer assembly PN 12940880.

- 1 Remove two wire swaging sleeves (10) from ends of wire rope (7). This will release machine bolt (6) and retainer assembly (8) from end of wire rope. Discard wire swaging sleeves. Replace wire rope if frayed or broken.
- 2 Remove four self-locking screws (11) from retainer assembly (8). Discard self-locking screws.
- 3 Remove access cover (12), rubber bushing (13), and four serrated lock rings (14), from retainer body assembly (15). Discard serrated lock rings.
- 4 If necessary for replacement, remove decals (16, 17, and 18).



**NOTE**

Steps 5 through 10 pertain to retainer assembly PN 12940880.

- 5 Remove two wire swaging sleeves (19) from ends of wire rope (7). This will release machine bolt (6) and retainer assembly (8) from end of wire rope. Discard wire swaging sleeves. Replace wire rope if frayed or broken.
- 6 Remove four self-locking screws (20) from retainer assembly (8). Discard self-locking screws.
- 7 Remove end plate (21) and rubber insert (22) from inner ring (23).
- 8 Remove spring pin (24) and locking pin (25) from outer ring (26). Discard spring pin.
- 9 Remove four self-locking screws (27) and outer ring (26) from inner ring (23). Discard self-locking screws.

**NOTE**

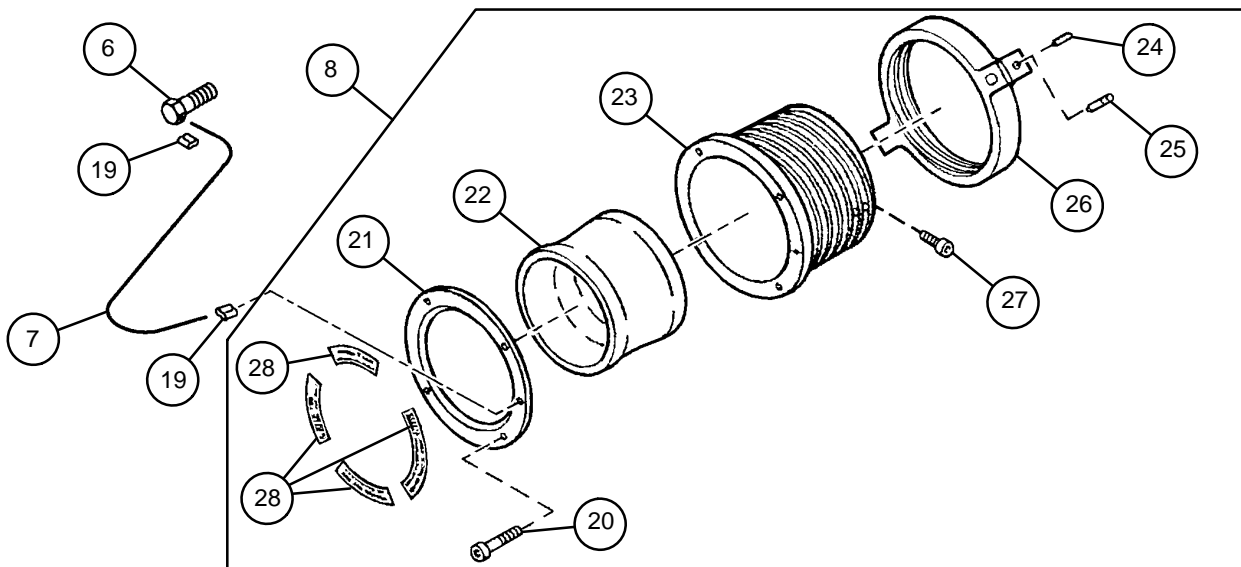
Perform step 10 if end plate is being replaced or if decals are illegible.

- 10 Remove four decals (28) from end plate (21). Discard decals.

**c. Assembly****NOTE**

- Refer to steps 1 through 3 to assemble retainer assembly 12940880.
- Refer to steps 4 through 6 to assemble retainer assembly 11828875.
- Cut hole in decal to match hole in end plate hole where wire rope passes through, being careful not to obliterate arrow on decal.

- 1 Install four new decals (28) on end plate (21).
- 2 Install outer ring (26), locking pin (25), new spring pin (24), and four new self-locking screws (27) on inner ring (23).
- 3 Install rubber insert (22), end plate (21), and four new self-locking screws (20) on inner ring (23).



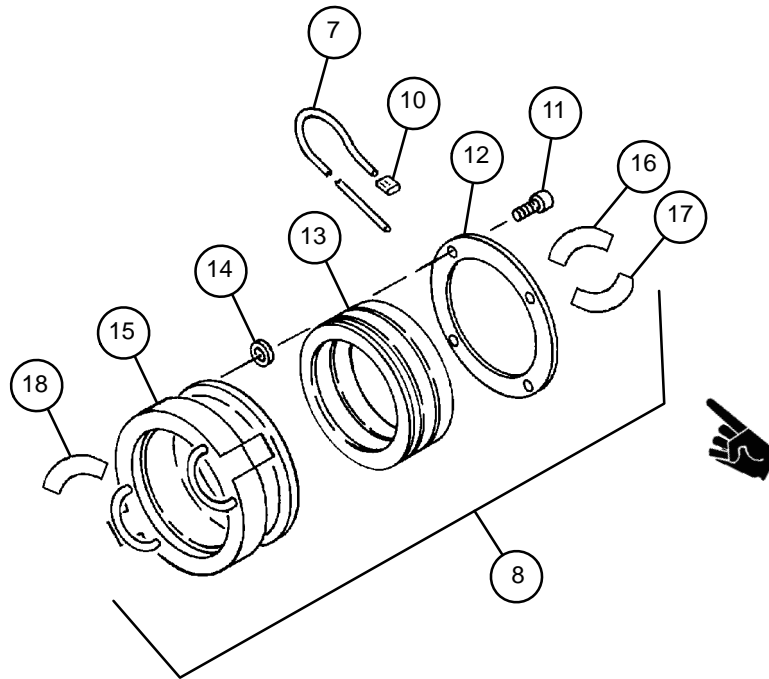
---

## 15-1 RETAINER ASSEMBLY — CONTINUED

---

### c. Assembly – Continued

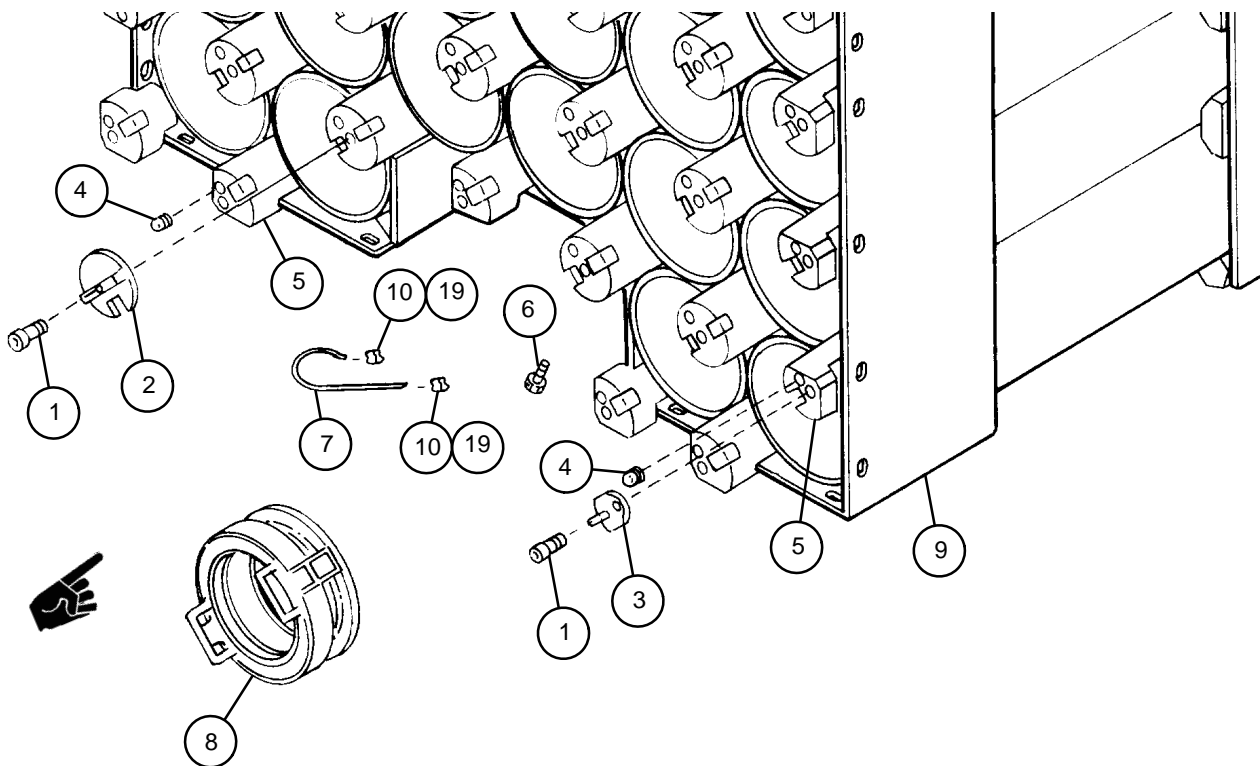
- 4 Install decals (16, 17, and 18), if necessary for replacement (para 2-7).
- 5 Install rubber bushing (13) into retainer body assembly (15).
- 6 Install four new serrated lock rings (14), access cover (12), and four new self-locking screws (11) on retainer body assembly (15).





**d. Installation**

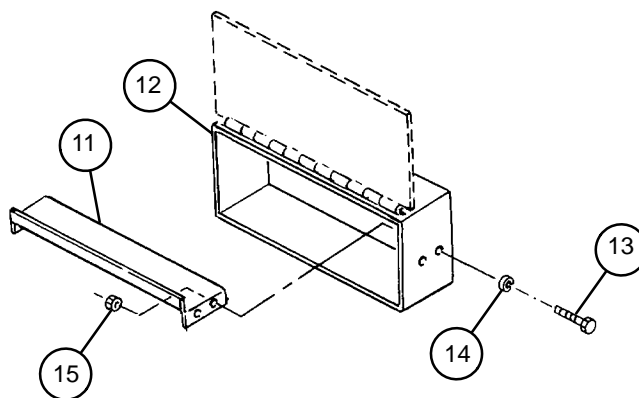
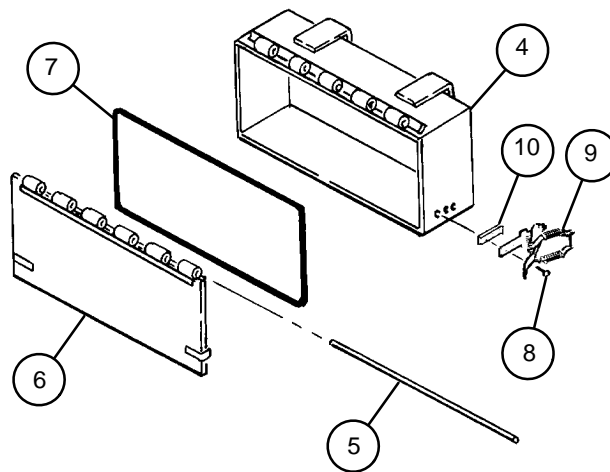
- 1 Apply sealing compound to threads of machine bolt (6).
- 2 Install machine bolt (6) on post (5).
- 3 Insert the end of wire rope (7) into nearest machine bolt (6) on post (5). Make a loop at the end of the wire rope and crimp new wire swaging sleeve (10 or 19) onto wire rope at base of loop. Tighten machine bolt to post.
- 4 Insert free end of wire rope (7) into hole on retainer assembly (8). Make a loop at the end of the wire rope and crimp new wire swaging sleeve (10 or 19) onto wire rope at base of loop.
- 5 Install retainer assembly (8) on projectile stowage rack assembly (9).
- 6 Install two quick-release plungers (4), two locking caps (2 or 3), and two shoulder screws (1) on two nearest posts (5). This will secure retainer assembly (8) on projectile stowage rack assembly (9). Torque shoulder screws to 15–20 ft–lb (20–27 N·m). Adjust quick-release plungers until contact is made with locking caps.





**b. Disassembly**

- 1 Remove straight rod (5) from hinge of access door (6) on top right rear stowage box (4).
- 2 Remove access door (6).
- 3 Remove seal (7) from access door (6). Discard seal.
- 4 Remove six rivets (8), two rim latches (9), and two plate spacers (10) from sides of top right rear stowage box (4). Discard rivets and plate spacers.
- 5 Repeat procedures in steps 1 through 4 for remaining three rear stowage boxes.
- 6 Remove shelf (11) from bottom right stowage box (12) by removing four cap screws (13), four lockwashers (14), and four hex nuts (15). Discard lockwashers.
- 7 Repeat step 6 for bottom left stowage box.



---

## 15-2 EXTERIOR STOWAGE BOXES — CONTINUED

---

### c. Assembly

#### NOTE

If bottom stowage box (12) is new from supply, perform step 1.

- 1 Using shelf (11) as a template, drill four holes 9/32 inch (7.14 mm) through bottom stowage box (12) approximately 4.5 inches (11.43 cm) from bottom of stowage box.
- 2 Install shelf (11) in bottom right stowage box (12) using four hex nuts (15), four new lockwashers (14), and four cap screws (13).
- 3 Repeat step 2 for bottom left stowage box with holes or repeat steps 1 and 2 if bottom left stowage box is new from supply.
- 4 Install two new plate spacers (10) and two rim latches (9) on sides of top right rear stowage box (4) using six new rivets (8).

**WARNING**

Adhesives can burn easily, can give off harmful vapors, and are harmful to skin and clothing. To avoid injury or death, keep away from open fire and use in well-ventilated area. If adhesive gets on skin or clothing, wash immediately with soap and water.

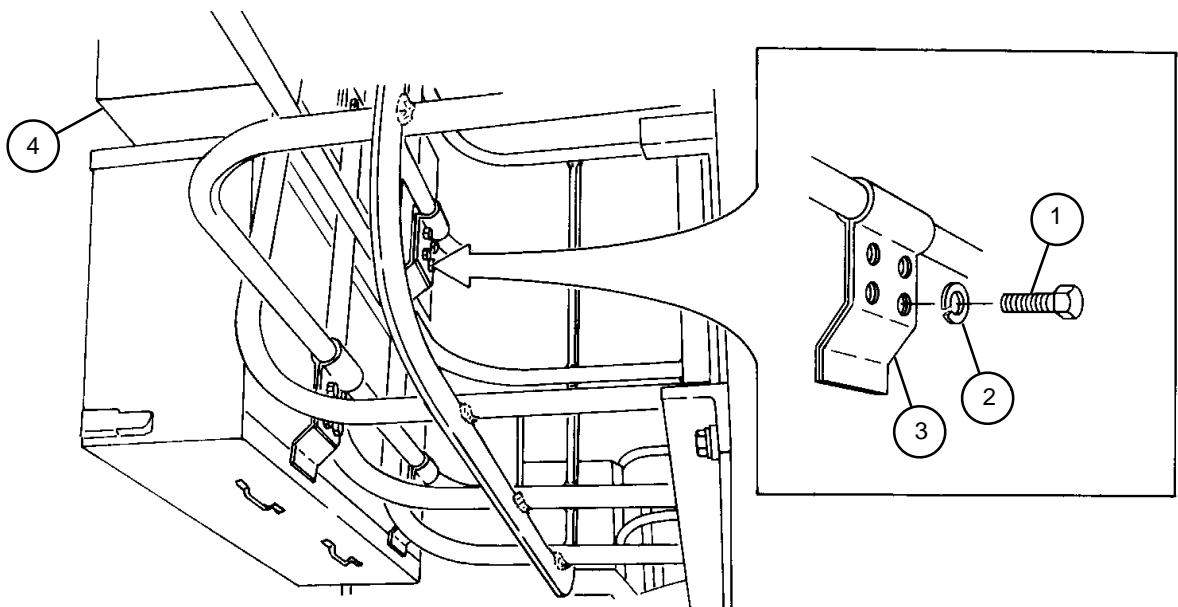
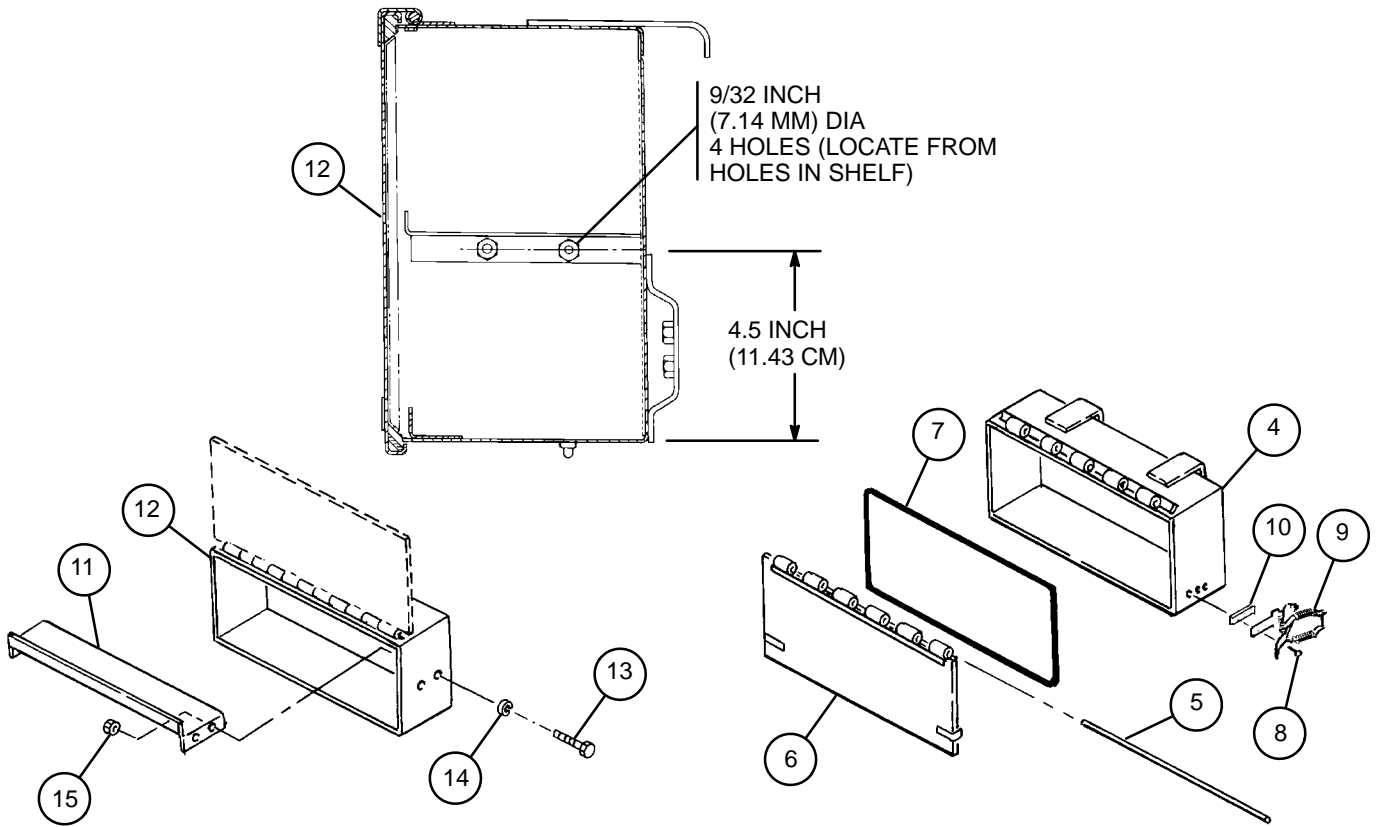
- 5 Clean seal seat inside access door (6). Apply adhesive to cleaned seal seat and to new seal (7). Install seal on access door.
- 6 Using straight rod (5), install access door (6) on hinge of top right rear stowage box (4).
- 7 Repeat procedures in steps 4 through 6 for remaining three rear stowage boxes.

### d. Installation

**CAUTION**

Bottom stowage box should be staggered to outside edge of rack assembly to prevent damage to cover by bustle door handle (not illustrated).

- 1 Hang two retaining straps (3) on basket as shown.
- 2 Using eight new lockwashers (2) and eight machine bolts (1), attach top right rear stowage box (4) to two retaining straps (3).
- 3 Repeat procedure in steps 1 and 2 for remaining three rear stowage boxes.



---

## 15-3 M27 PERISCOPE STOWAGE BOX

---

This task covers: a. Removal

b. Installation

---

### **INITIAL SETUP**

Applicable Configuration

M109A4/M109A5 howitzers

Tools

Artillery and turret mechanic's tool kit  
(SC 5180-95-CL-A12)

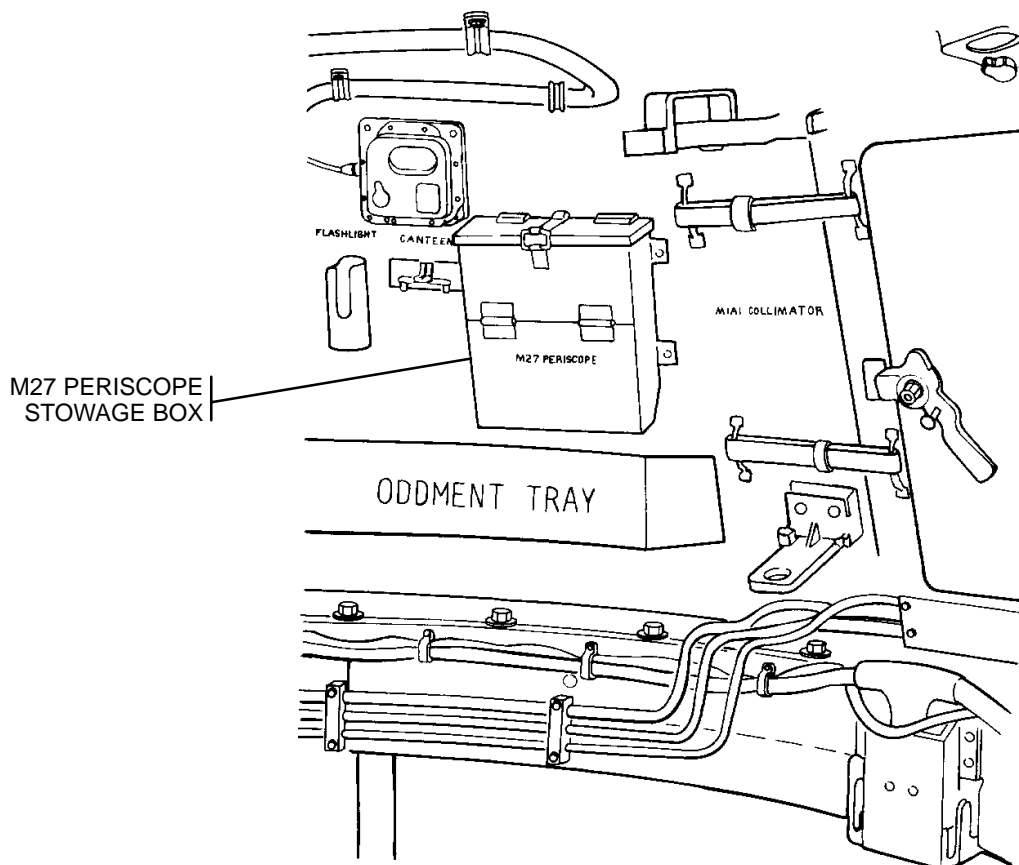
Materials/Parts

Lockwashers (4) (item 55, Appx G)

Equipment Condition

Vehicle MASTER switch to OFF (TM 9-2350-311-10)  
CAB NBC POWER switch to OFF (TM 9-2350-311-10)  
M27 periscope removed from stowage box

---



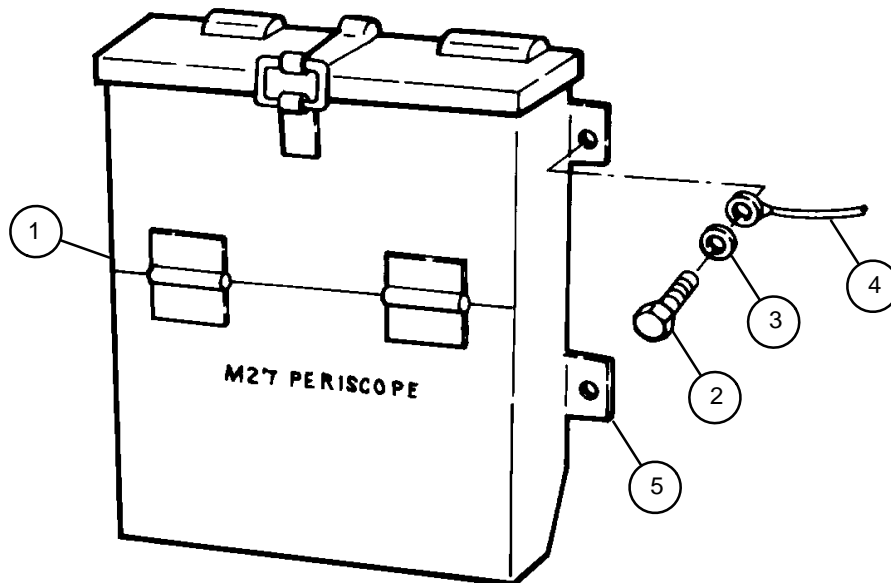
**a. Removal****NOTE**

NBC ground lead is only attached to M27 stowage box on M109A4/M109A5 howitzers.

- 1 Support M27 periscope stowage box (1) while removing four cap screws (2), four lockwashers (3), and ground lead (4) from four brackets (5) holding M27 periscope stowage box to cab. Discard lockwashers.
- 2 Remove M27 periscope stowage box (1).

**b. Installation**

- 1 Position M27 periscope stowage box (1).
- 2 Install ground lead (4), four new lockwashers (3), and four cap screws (2) through four brackets (5) on M27 periscope stowage box (1).





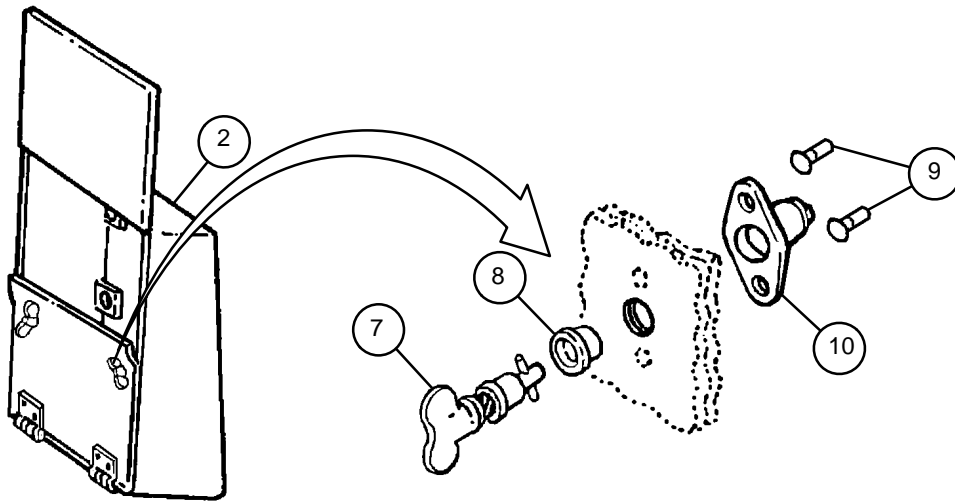


**b. Disassembly**

- 1 Remove turnlock stud assembly (7) and turnlock eyelet (8) from oddment storage box (2).
- 2 Remove two rivets (9) and turnlock receptacle (10). Discard rivet.
- 3 Repeat steps 1 and 2 for second turnlock stud assembly.

**c. Assembly**

- 1 Install turnlock receptacle (10) and two new rivets (9).
- 2 Install turnlock eyelet (8) and turnlock stud assembly (7).
- 3 Repeat steps 1 and 2 for second turnlock stud assembly on oddment storage box (2).



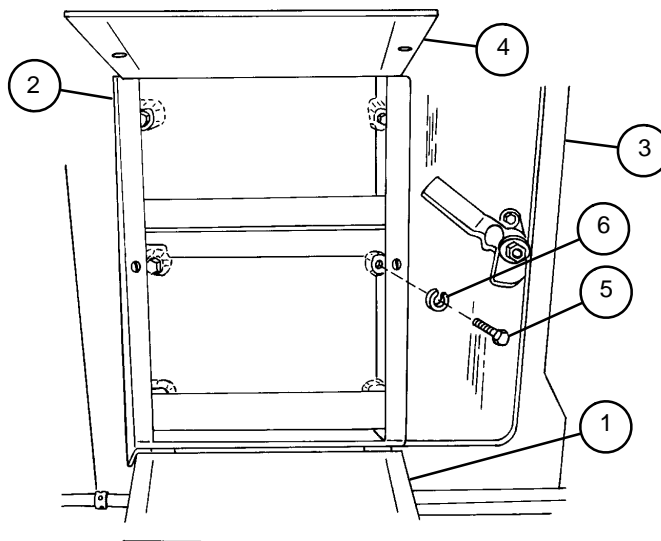
---

## 15-4 ODDMENT STOWAGE BOXES – CONTINUED

---

■ d. Installation

- 1 Aline six screw holes on inside of oddment stowage box (2) with six screw holes on left side cab door (3).
- 2 Install six cap screws (5) and six new lockwashers (6) to mount oddment stowage box (2) on left side cab door (3).
- 3 Close top door (4) of oddment stowage box (2). Close bottom door (1).





---

## 15-6 COLLIMATOR CONTROL BRACKET

---

This task covers:    a. Removal                                    b. Installation

---

### INITIAL SETUP

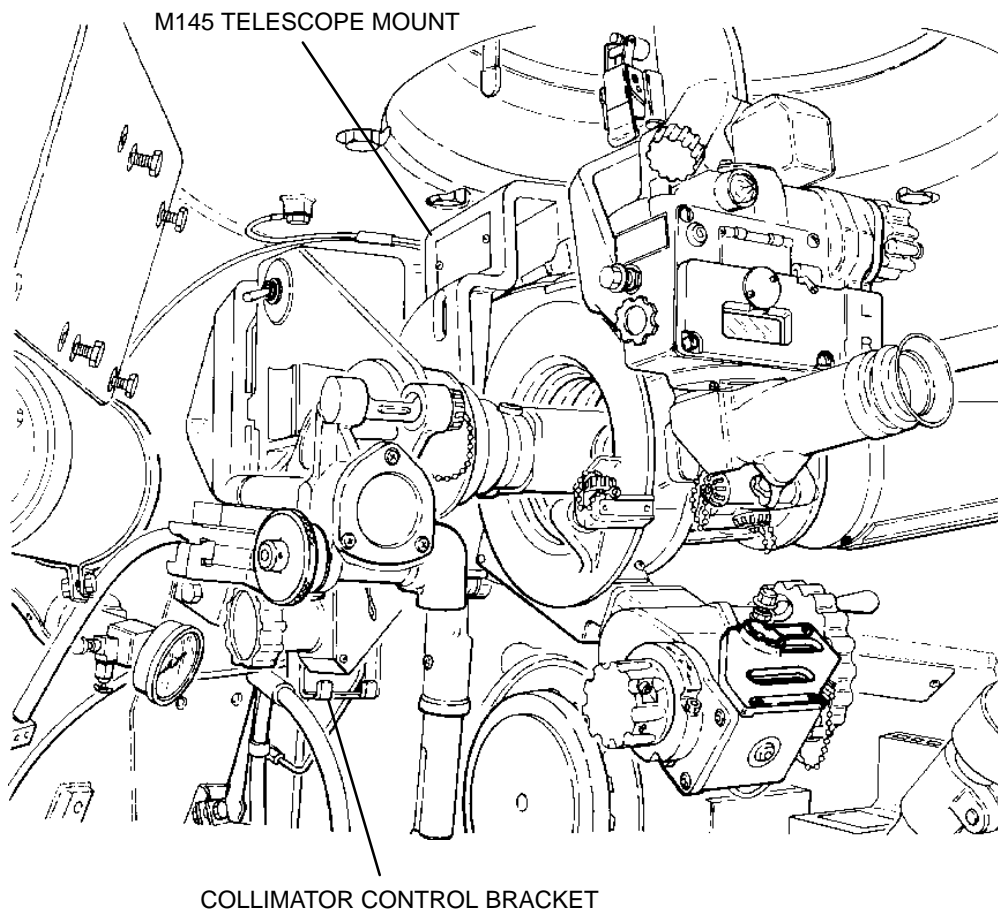
#### Tools

Artillery and turret mechanic's tool kit  
(SC 5180-95-CL-A12)

---

#### NOTE

This bracket is used only with the M1 collimator for holding the remote control light source.

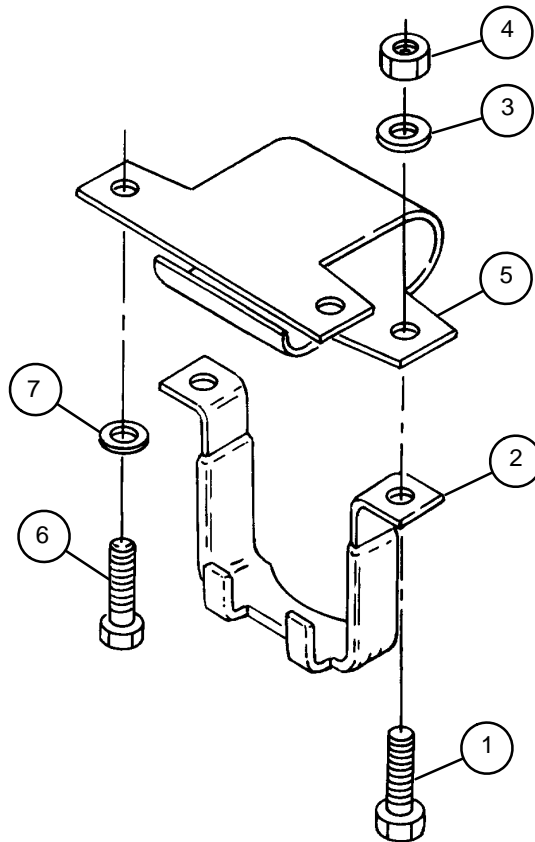


**a. Removal**

- 1 Remove two machine bolts (1), stowage bracket (2), two flat washers (3), and two hex nuts (4) from multiple bracket (5).
- 2 Remove two cap screws (6) and four flat washers (7). This will release multiple bracket (5) from M145/M145A1 telescope mount.

**b. Installation**

- 1 Position multiple bracket (5) on M145/M145A1 telescope mount and install four flat washers (7) and two cap screws (6).
- 2 Install two hex nuts (4), two flat washers (3), stowage bracket (2), and two machine bolts (1) into multiple bracket (5).





## 15-8 SIGNAL FLARE BRACKET ASSEMBLY

This task covers: a. Removal b. Installation

### INITIAL SETUP

Tools

Artillery and turret mechanic's tool kit  
(SC 5180-95-CL-A12)

Materials/Parts

Lockwashers (4) (item 55, Appx G)

#### a. Removal

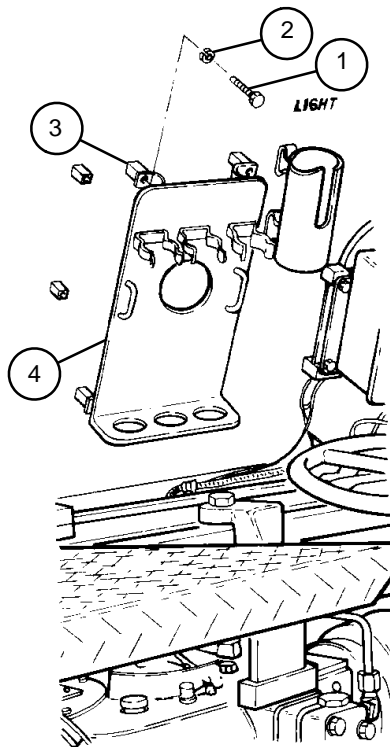
#### NOTE

Remove flares from signal flare bracket assembly before beginning this procedure.

Remove four cap screws (1) and four lockwashers (2) from four mounting brackets (3) holding signal flare bracket assembly (4) to cab. Discard lockwashers.

#### b. Installation

Install four new lockwashers (2) and four cap screws (1) through four mounting brackets (3) to hold signal flare bracket assembly (4) to cab.







a. Removal

**NOTE**

This procedure is written for one rifle clip, but also applies to all others.

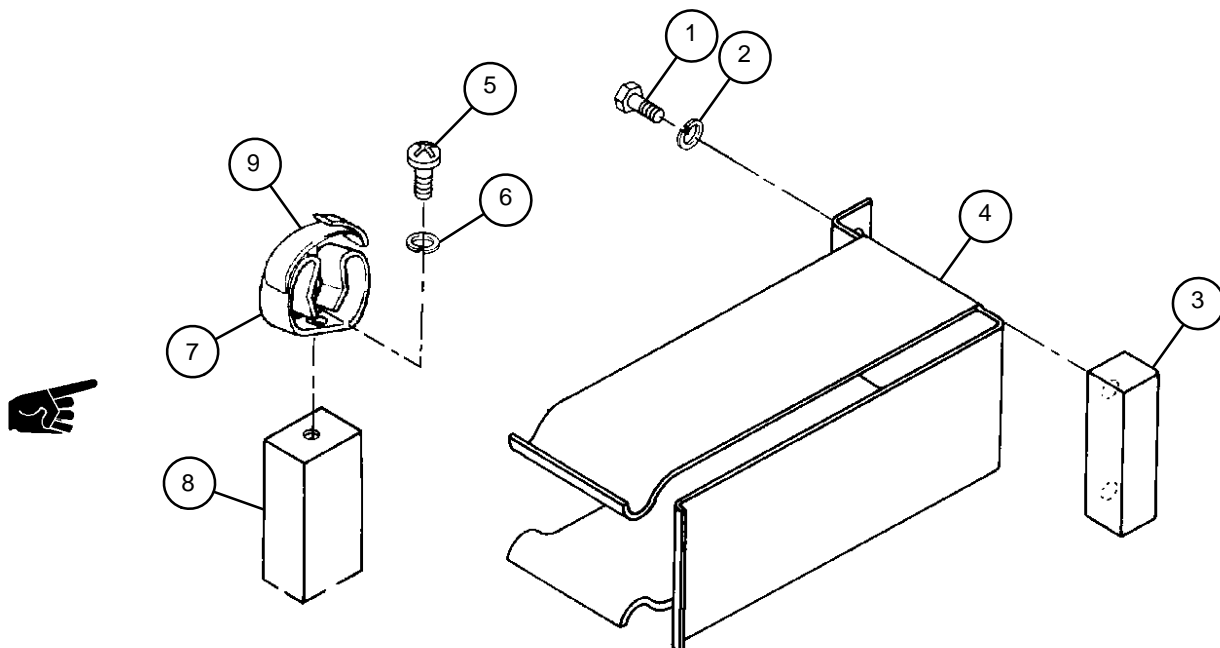
- 1 Remove two cap screws (1) and two lockwashers (2) from mount (3). Remove rifle clip (4). Discard lockwashers.
- 2 Remove one machine screw (5) and one lockwasher (6). Remove rifle spring clip (7) from mount (8). Discard lockwasher.
- 3 Remove strap (9) from rifle spring clip (7).

b. Installation

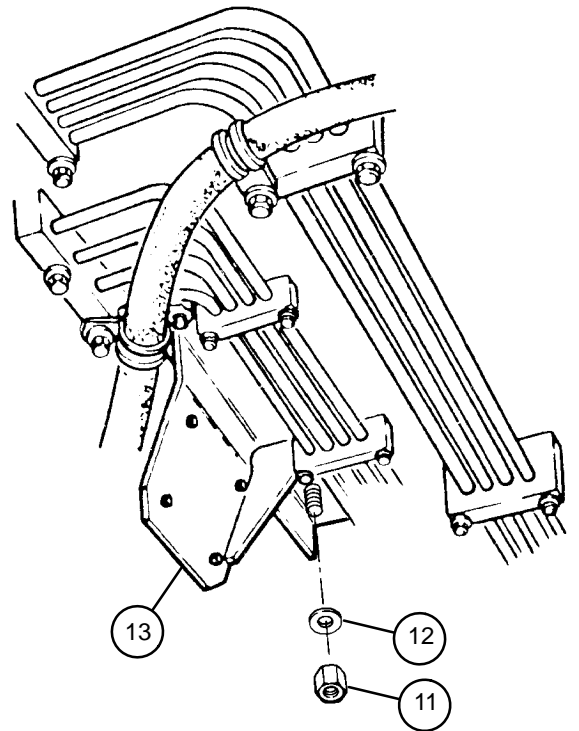
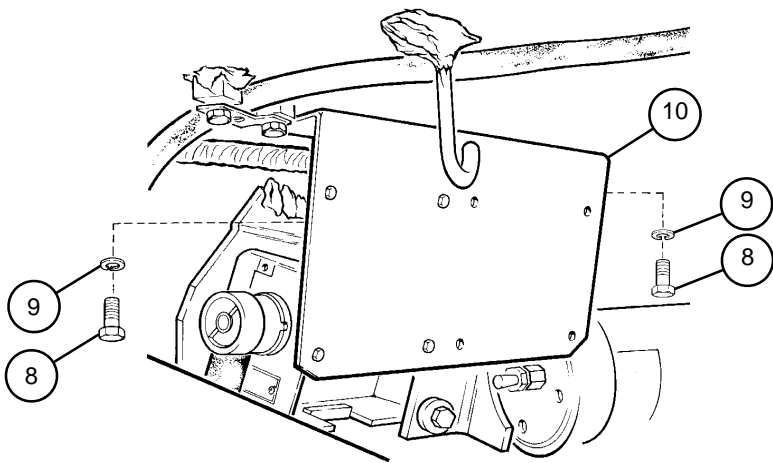
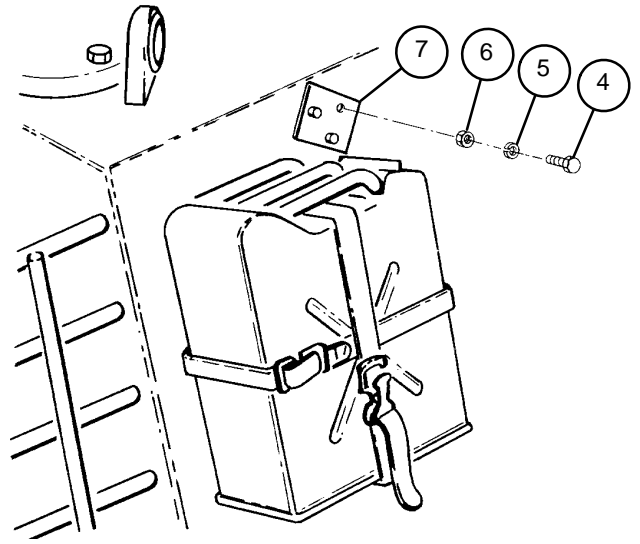
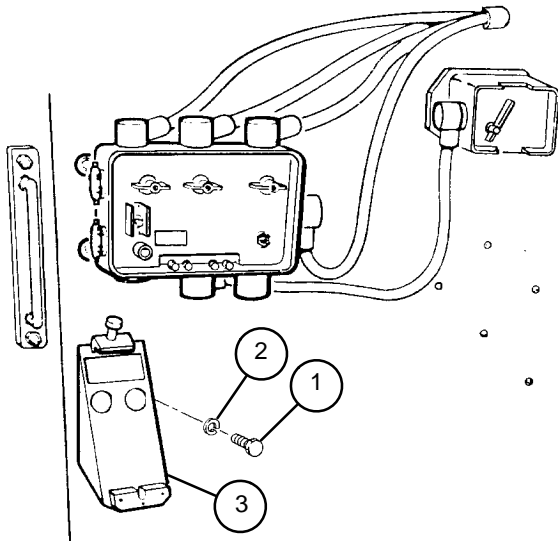
**WARNING**

Adhesives can burn easily, can give off harmful vapors, and are harmful to skin and clothing. To avoid injury or death, keep away from open fire and use in well-ventilated area. If adhesive gets on skin or clothing, wash immediately with soap and water.

- 1 Apply adhesive to rifle spring clip (7), then install strap (9).
- 2 Position rifle spring clip (7) on mount (8) and install one new lockwasher (6) and one machine screw (5).
- 3 Position rifle clip (4) on mount (3) and install two new lockwashers (2) and two cap screws (1).







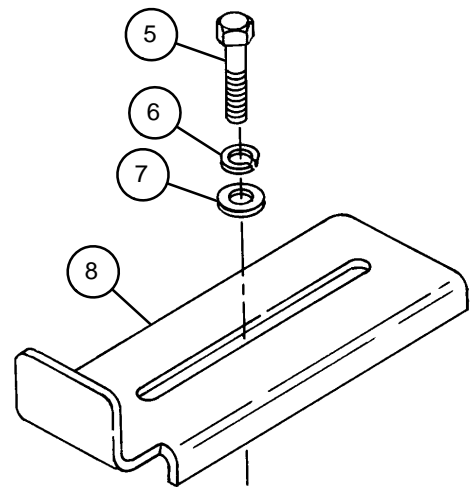
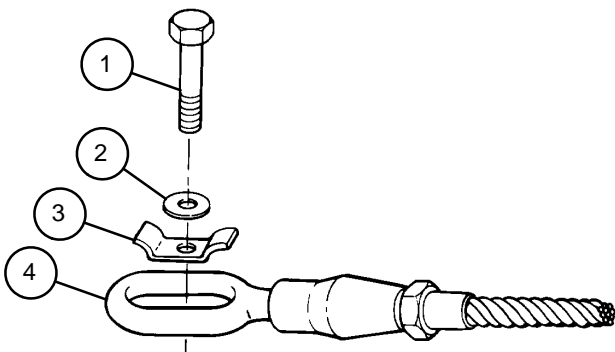


**a. Removal**

- 1 Remove cap screw (1), flat washer (2), and towing cable strap (3) to release tow cable (4).
- 2 Repeat step 1 for other end of tow cable (4).
- 3 Remove cap screw (5), lockwasher (6), flat washer (7), and angle bracket (8) from top of cab. Discard lockwashers.

**b. Installation**

- 1 Install angle bracket (8), flat washer (7), new lockwasher (6), and cap screw (5) to top of cab.
- 2 Install tow cable (4) using towing cable strap (3), flat washer (2), and cap screw (1).
- 3 Repeat step 2 for other end of tow cable (4).



---

## Section IV. STOWAGE RACKS

---

### 15-12 CANNISTER STOWAGE BRACKET ASSEMBLY

---

This task covers: a. Removal

b. Installation

---

#### **INITIAL SETUP**

##### Tools

Artillery and turret mechanic's tool kit  
(SC 5180-95-CL-A12)

##### Materials/Parts

Lockwashers (5) (item 79, Appx G)  
Sealing compound (item 32, Appx D)

Self-locking nuts (6) (item 183, Appx G)

Zinc chromate paste (item 23, Appx G)

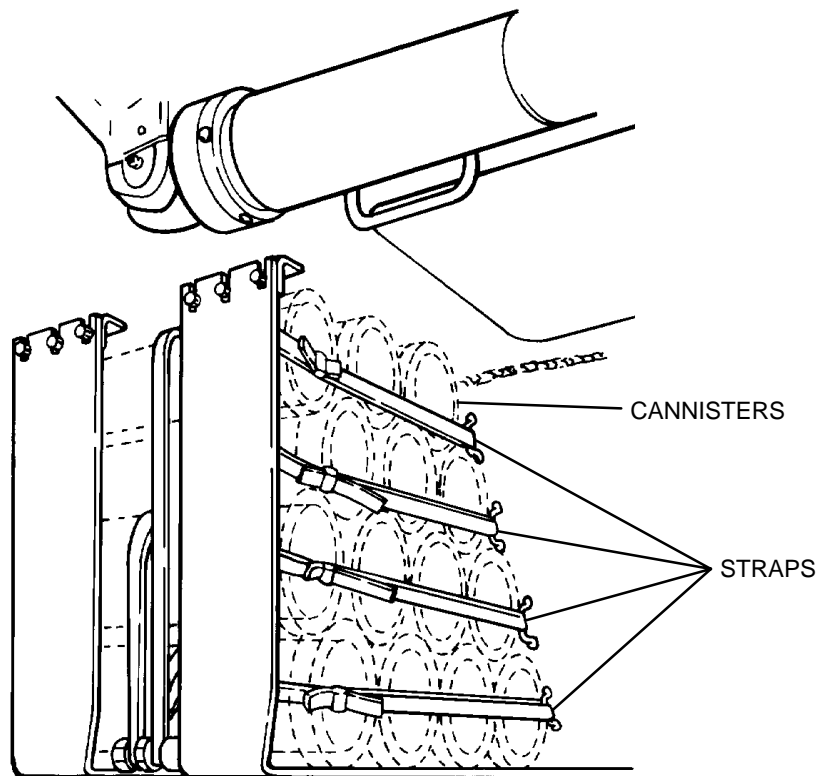
##### Personnel required

2

##### Equipment Condition

Cannisters and straps removed

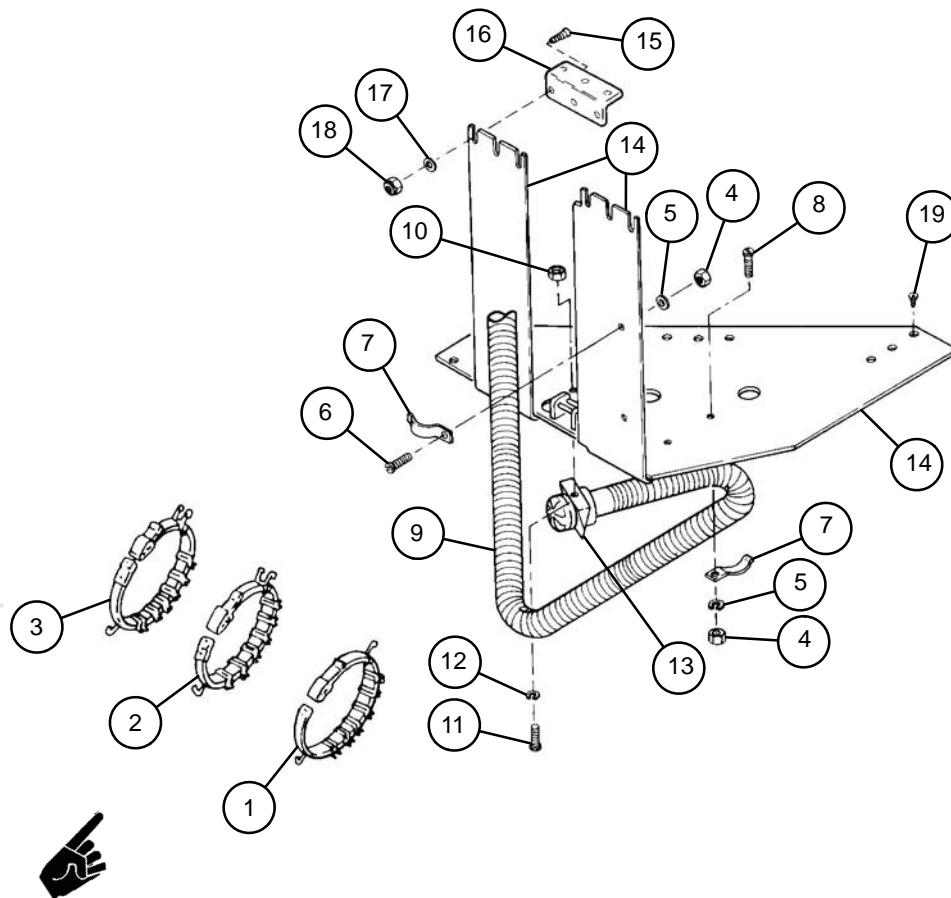
---



CANNISTER STOWAGE BRACKET ASSEMBLY

**a. Removal**

- 1 Remove four retaining straps (1), three retaining straps (2), and retaining strap (3).
- 2 Remove four hex nuts (4), four lockwashers (5), two cap screws (6), four loop clamps(7) and two machine screws (8) to release NBC hose (9). Discard lockwashers.
- 3 Remove hex nut (10), machine screw (11), lockwasher (12), and cannoneer no. 1's orifice connector bracket (13) from bracket assembly (14). Discard lockwashers.
- 4 Remove six machine screws (15), two angle brackets (16), six flat washers (17), and six self-locking nuts (18) from vertical brackets on bracket assembly (14). Discard self-locking nuts.
- 5 Remove 14 machine screws (19) from bracket assembly (14). Slide bracket assembly out to remove.



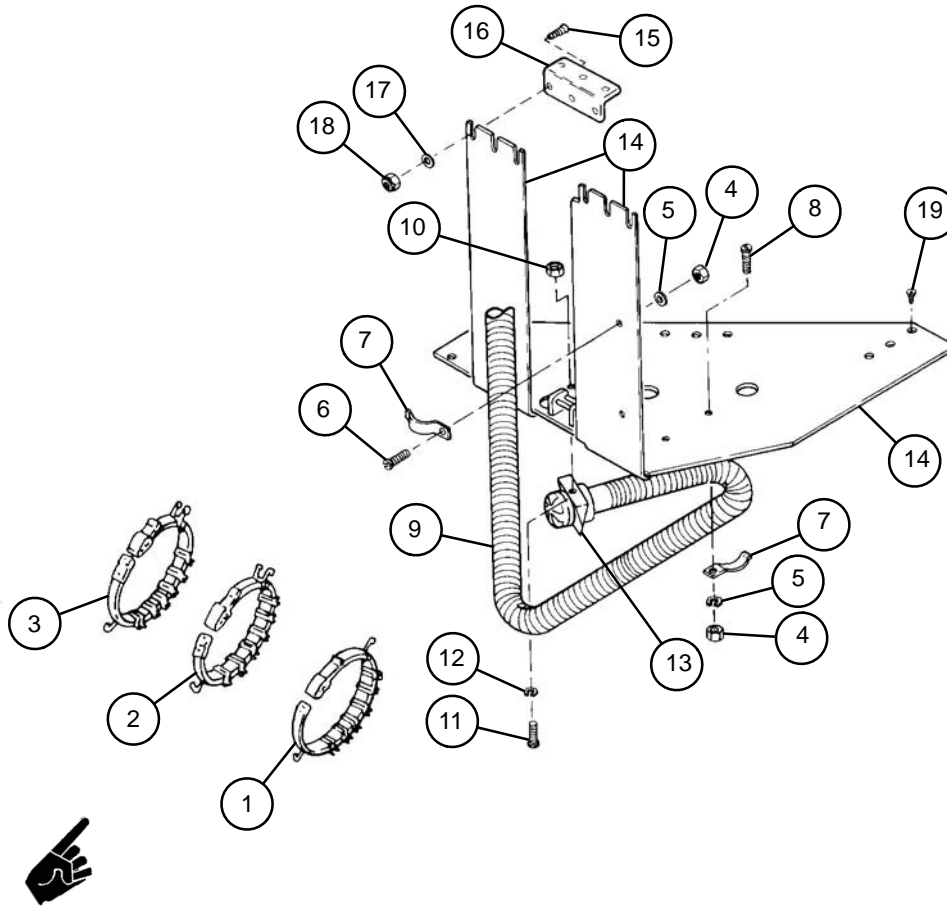
**15-12 CANNISTER STOWAGE BRACKET ASSEMBLY — CONTINUED**

**b. Installation**

**NOTE**

Apply zinc chromate paste between contact surfaces where aluminum meets steel. Apply sealing compound to all machine screws before installing.

- 1 Slide bracket assembly (14) into place and install 14 machine screws (19).
- 2 Install six new self-locking nuts (18), six flat washers (17), two angle brackets (16), and six machine screws (15) on two vertical brackets on bracket assembly (14).
- 3 Install four loop clamps (7) using two cap screws (6), two machine screws (8), four new lockwashers (5), and four hex nuts (4).
- 4 Install cannoneer no. 1's orifice connector bracket (13) using machine screw (11), new lockwasher (12), and hex nut (10).
- 5 Install NBC hose (9) in loop clamps (7).
- 6 Install retaining strap (3), three retaining straps (2), and four retaining straps (1).





## 15-13 REAR STOWAGE RACKS

This task covers: a. Removal b. Installation

### INITIAL SETUP

Tools

Artillery and turret mechanic's tool kit  
(SC 5180-95-CL-A12)

Materials/Parts

Lockwashers (12) (item 87, Appx G)

### NOTE

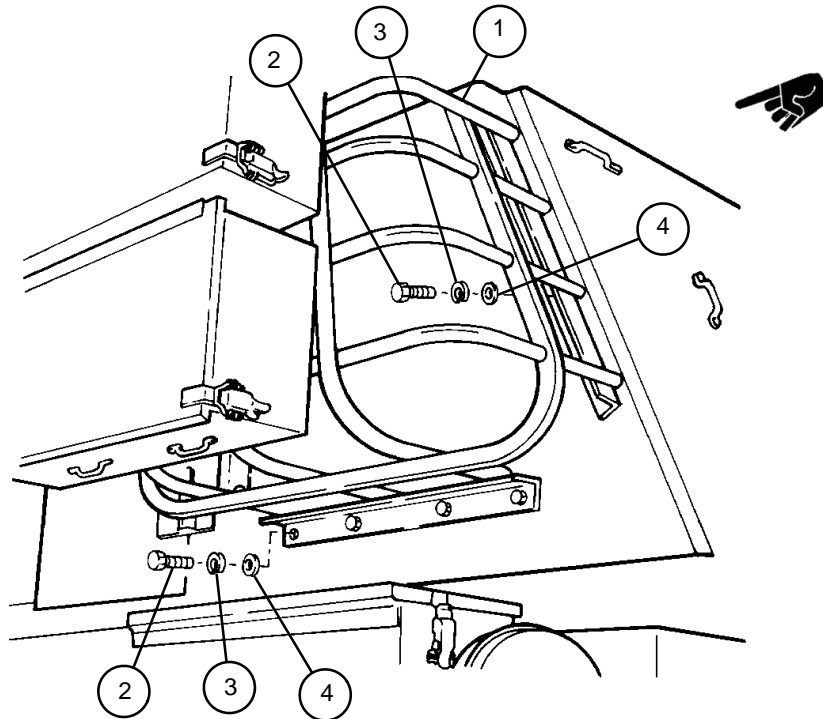
Procedure is written for right rear stowage rack, but also applies to left rear stowage rack.

#### a. Removal

Remove right rear stowage rack (1) by removing 12 cap screws (2), 12 lockwashers (3), and 12 flat washers (4).

#### b. Installation

Position right rear stowage rack (1) and install 12 flat washers (4), 12 new lockwashers (3), and 12 cap screws (2).





## CHAPTER 16 PANORAMIC TELESCOPE BALLISTIC COVER

---

### GENERAL

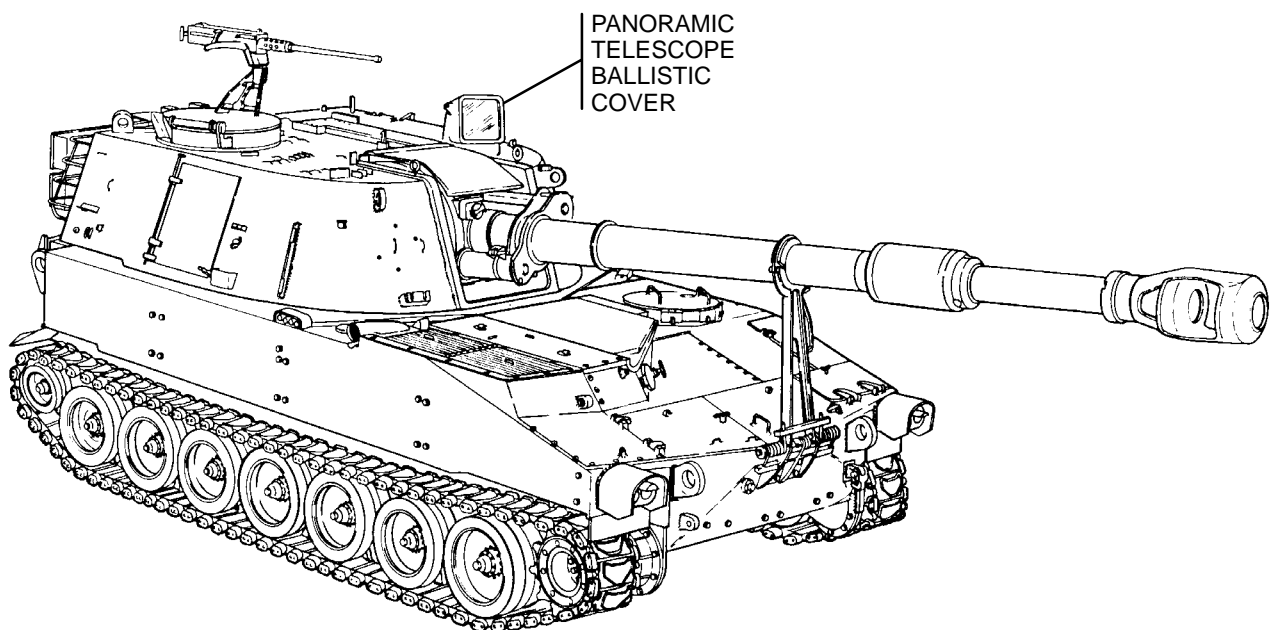
This chapter explains how to remove and install the panoramic telescope ballistic cover.

---

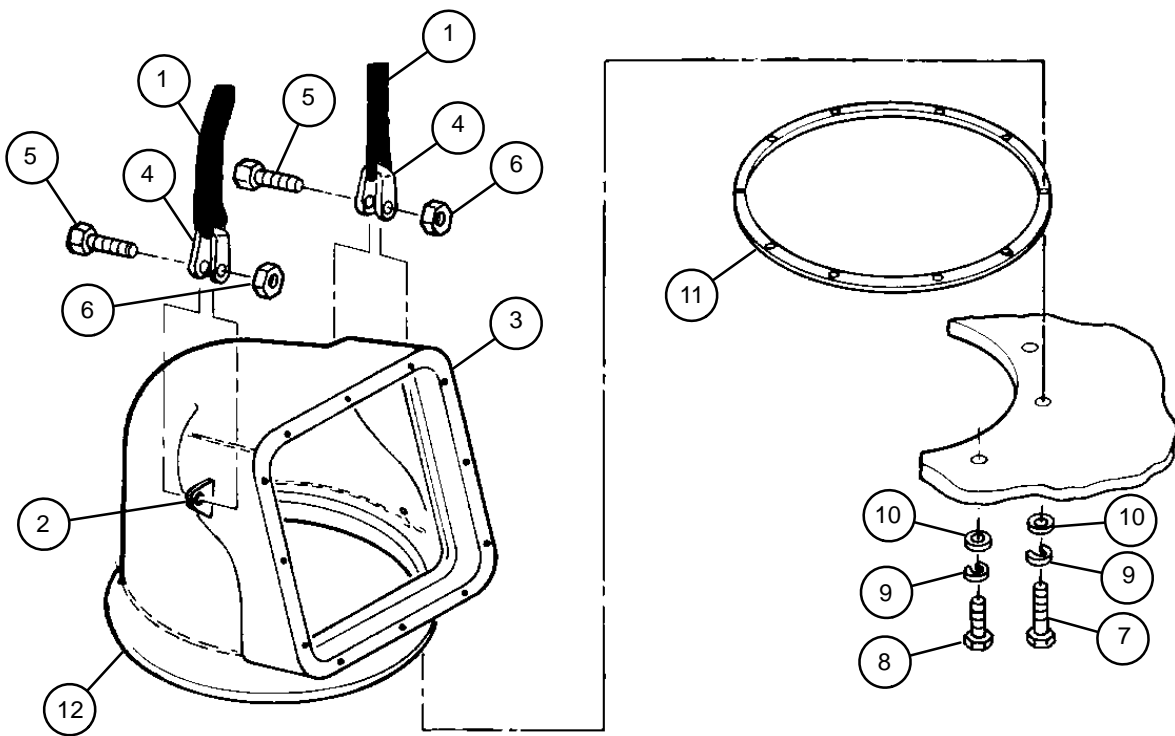
### CONTENTS

Page

PANORAMIC TELESCOPE BALLISTIC COVER ..... 16-2









# CHAPTER 17

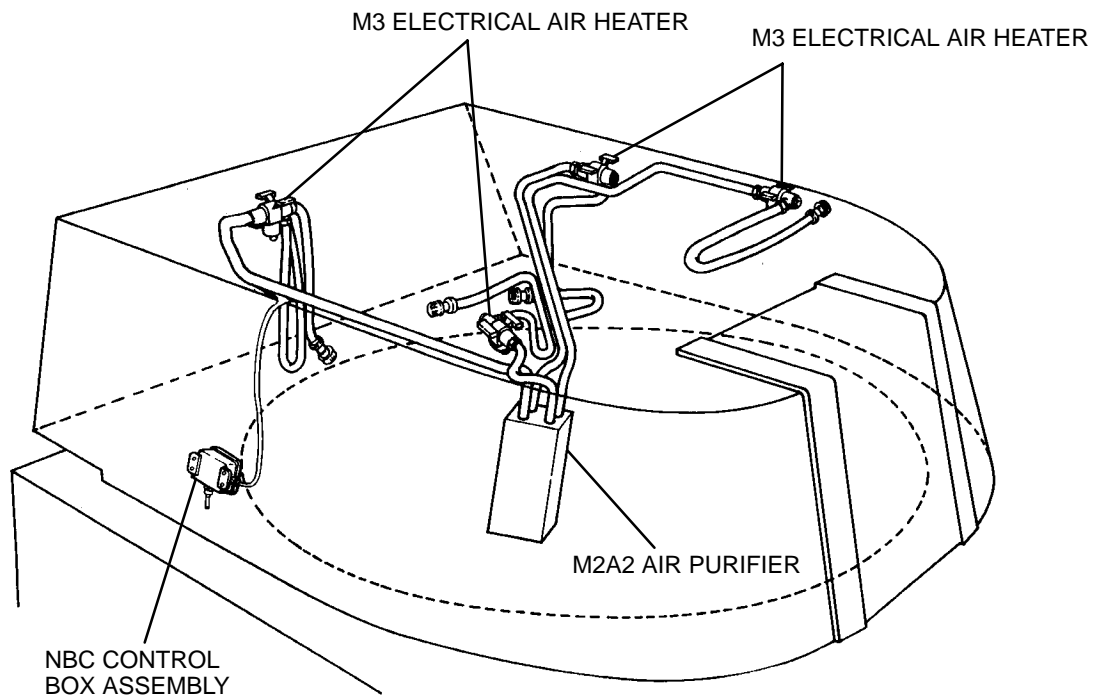
## NUCLEAR, BIOLOGICAL, AND CHEMICAL (NBC) PROTECTION EQUIPMENT

### GENERAL

This chapter describes unit maintenance procedures for NBC system on M109A4/M109A5 howitzers. Removal, disassembly, assembly, installation, repair, inspection, and testing procedures are included. NBC power lead assembly and ground lead maintenance is located in Chapter 8, Cab Electrical System. A general inspection is provided for all applicable parts.

### CONTENTS

	<u>Page</u>
17-1 GENERAL INSPECTION AND REPAIR PROCEDURES .....	17-2
17-2 M3 ELECTRICAL AIR HEATER .....	17-3
17-3 M2A2 AIR PURIFIER AND BRACKET .....	17-8
17-4 NBC CONTROL BOX ASSEMBLY .....	17-13
17-5 HOSES AND FITTINGS .....	17-19
17-6 AIR OUTLET ORIFICE CONNECTOR .....	17-28



## 17-1 GENERAL INSPECTION AND REPAIR PROCEDURES

---

This task covers: Inspecting NBC System

---

### Inspecting NBC System

The mechanic will perform a visual inspection of the NBC system during removal and disassembly. During inspection, perform the following checks and take the indicated action if the condition exists.

**WARNING**

Failure to observe proper decontamination procedures can result in death. Refer to TM 9-2350-311-10 for decontamination procedures. Only trained personnel shall perform maintenance on contaminated equipment (FM 3-3 and FM 3-5).

- 1 Check for cracked, damaged, deteriorated, or broken hoses. Replace.
- 2 Check for frayed, deteriorated, or broken electrical leads. Repair.
- 3 Check for broken, damaged, or loose-fitting retainer straps and brackets. Replace.
- 4 Check for signs of shorted electrical circuits at connector assemblies. Repair lead terminals.





## 17-2 M3 ELECTRICAL AIR HEATER — CONTINUED

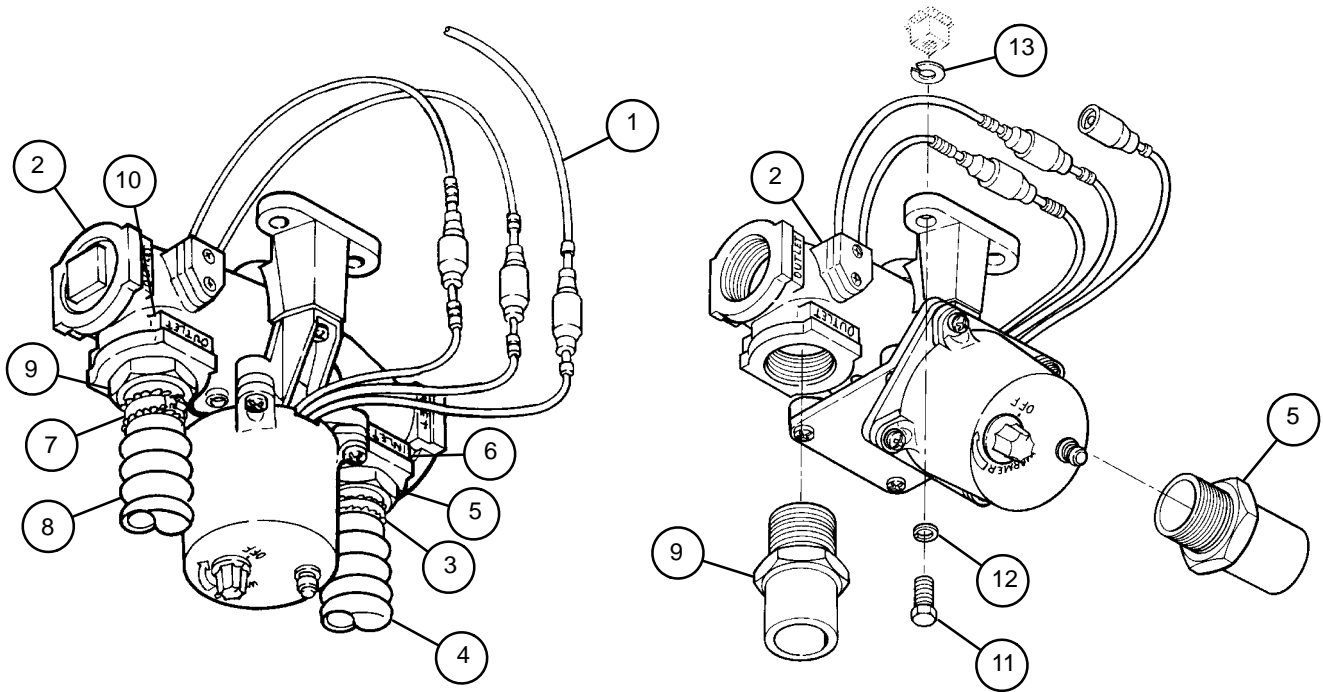
### a. Removal — Continued

- 2 Loosen hose clamp (3) and disconnect hose (4) from adapter (5) in inlet port (6) of M3 electrical air heater (2).
- 3 Loosen hose clamp (7) and disconnect hose (8) from adapter (9) in outlet port (10) of M3 electrical air heater (2).

#### NOTE

Section chief's station requires removal of a retaining strap, and cannoneer no. 1's station requires removal of a retaining strap and a washer when removing M3 electrical air heaters.

- 4 Remove four cap screws (11), four lockwashers (12), M3 electrical air heater (2), and four lockwashers (13) from cab ceiling. Discard all lockwashers.
- 5 Remove adapters (5 and 9).



## b. Disassembly

### WARNING

Be certain MASTER switch is in OFF position when working on electrical system to avoid electrical shock and burns.

- 1 Turn light lens (14) counterclockwise and remove.
- 2 Remove incandescent lamp (15) from M3 electrical air heater (2).

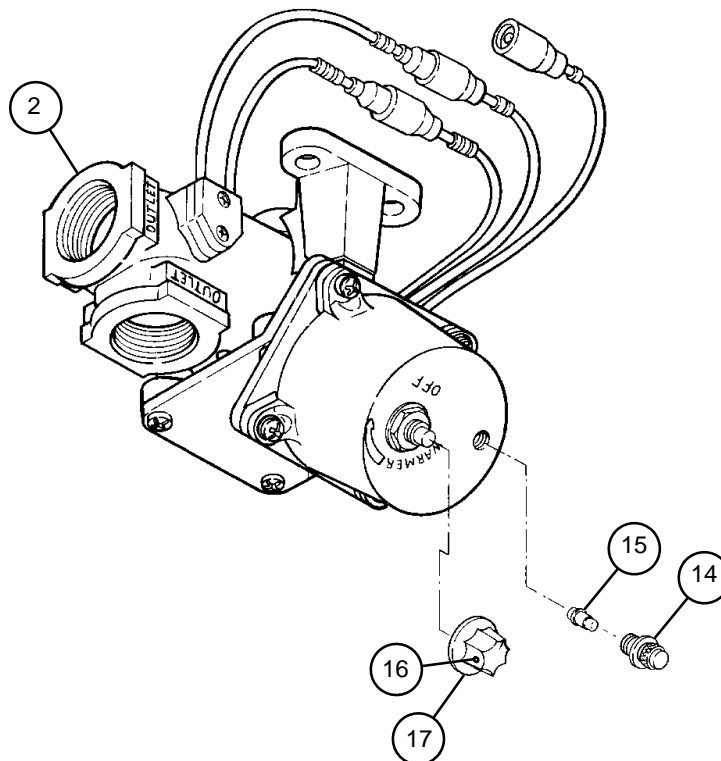
### NOTE

Be sure knob is in OFF position before removing.

- 3 Loosen screw (16) and pull knob (17) off M3 electrical air heater (2).

## c. Assembly

- 1 Install incandescent lamp (15).
- 2 Install light lens (14) in M3 electrical air heater (2) by turning clockwise.
- 3 Position knob (17) on M3 electrical air heater (2) in the OFF position and tighten screw (16).



## 17-2 M3 ELECTRICAL AIR HEATER — CONTINUED

### d. Installation

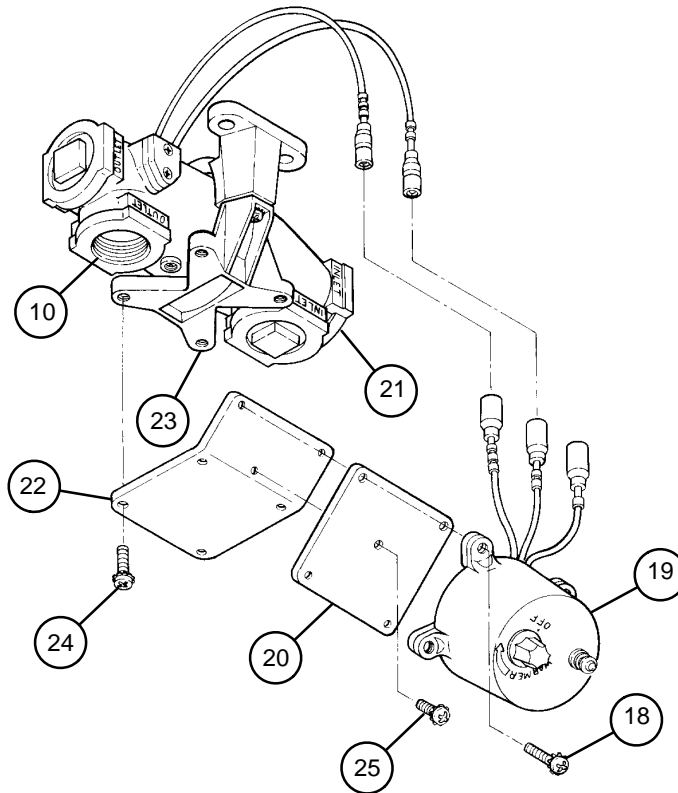
**WARNING**

Turn CAB POWER and MASTER switches to OFF before connecting electrical leads to avoid electrical shock and burn.

**NOTE**

M3 electrical air heaters at all stations except the section chief's must have heater kit assembled to them. Perform steps 1 through 4 to assemble kit. Section chief's M3 electrical air heater does not need the kit applied; proceed to step 5.

- 1 Remove four screws (18), control unit (19), and plate mount (20) from heater unit (21) and set aside.
- 2 Position angle bracket (22) on heater unit clamp (23) so outlet port (10) is to the right of the angle of the angle bracket. Secure using four screws (24).
- 3 Aline three holes on plate mount (20) with three holes on angle bracket (22) and install screw (25) in center hole.
- 4 Secure control unit (19) to plate mount (20) using four screws (18).



- 5 Install adapter (5) in inlet port (6) and adapter (9) in outlet port (10) of M3 electrical air heater (2).

**NOTE**

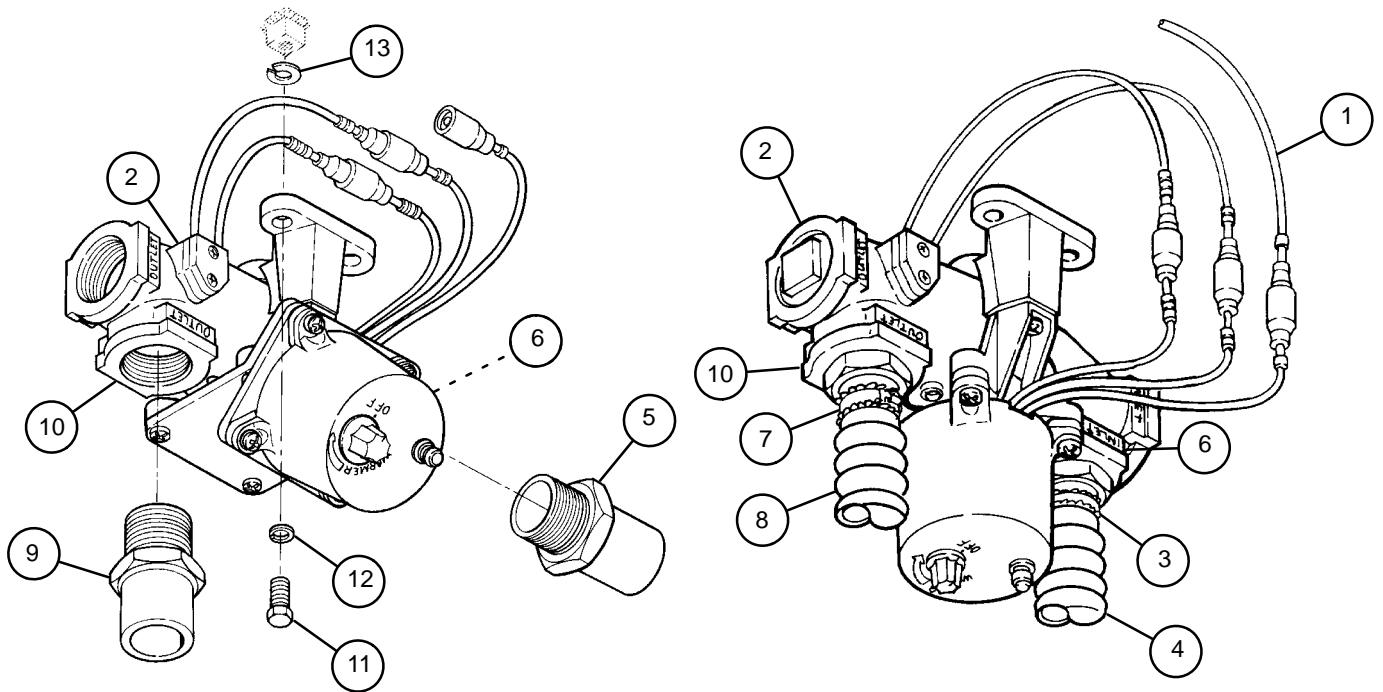
- Lockwashers (13) should be installed between mounting block and M3 electrical air heater.
- Install a washer and retaining strap with cannoneer no. 1's M3 electrical air heater. Reinstall a retaining strap with section chief's M3 electrical air heater.

- 6 Install M3 electrical air heater (2) on cab ceiling using four new lockwashers (13), four new lockwashers (12), and four cap screws (11).

- 7 Connect hose (8) from orifice connector to outlet port (10) of M3 electrical air heater (2) and hose clamp (7).

- 8 Connect hose (4) from M2A2 air purifier to the inlet port (6) and tighten hose clamp (3).

- 9 Plug NBC power lead assembly (1) into M3 electrical air heater (2).



---

## 17-3 M2A2 AIR PURIFIER AND BRACKET

---

This task covers:

a. Removal	b. Disassembly
c. Cleaning	d. Inspection
e. Assembly	f. Installation

---

### **INITIAL SETUP**

Applicable Configuration  
M109A4/M109A5 howitzers

Tools  
Artillery and turret mechanic's tool kit  
(SC 5180-95-CL-A12)

Materials/Parts  
Cloth (item 10, Appx D)  
Lockwasher (item 55, Appx G)  
Lockwashers (4) (item 77, Appx G)

Lockwashers (4) (item 79, Appx G)

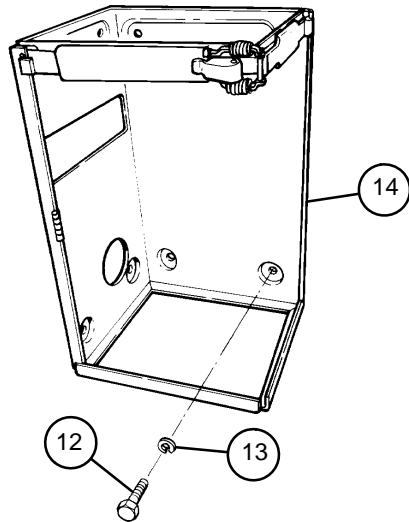
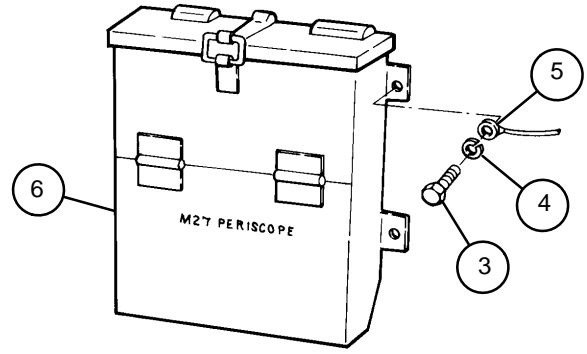
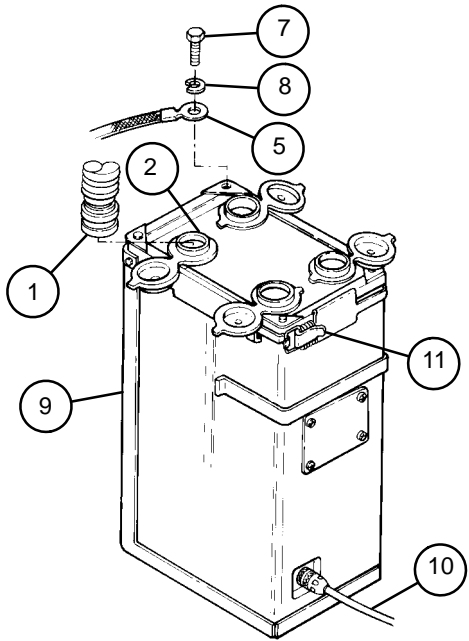
References  
AR 70-38  
FM 3-3  
FM 3-4  
TM 10-277

Equipment Condition  
CAB POWER switch to OFF (TM 9-2350-311-10)  
Vehicle MASTER switch to OFF (TM 9-2350-311-10)  
CAB NBC POWER switch to OFF (TM 9-2350-311-10)

---

#### **a. Removal**

- 1 Disconnect four hoses (1) from four air outlets (2).
- 2 Remove cap screw (3), lockwasher (4), and one end of ground lead (5) from M27 periscope box (6). Discard lockwasher.
- 3 Remove machine screw (7) and lockwasher (8) that secure the other end of ground lead (5) from top of M2A2 air purifier (9). Discard lockwasher.
- 4 Unplug NBC power lead assembly (10) from side of M2A2 air purifier (9).
- 5 Release strap (11) and lift out M2A2 air purifier (9).
- 6 Remove four cap screws (12) and four lockwashers (13) to remove angle bracket (14) from right front cab wall. Discard lockwashers.



---

**17-3 M2A2 AIR PURIFIER AND BRACKET — CONTINUED**

---

**b. Disassembly****WARNING**

To prevent possible chemical or biological agent casualties, contaminated filters must be removed and disposed of only by adequately trained personnel (FM 3-3 and FM 3-4). The unit commander or senior officer in charge of maintenance personnel assigned to remove and dispose of contaminated gas filters must prescribe necessary protective clothing (TM 10-277) to be worn during replacement.

- 1 Remove remaining three machine screws (7) and three lockwashers (8) from top of M2A2 air purifier (9). Discard lockwashers.
- 2 Remove manifold assembly (15).
- 3 If necessary for replacement, remove four protective dust caps (15.1) from manifold assembly (15).

**CAUTION**

Do not allow moisture to come in contact with filter material.

**NOTE**

If filters are to be removed and reused, mark arrow on side showing direction of air flow.

- 4 Tilt housing and precleaner (16) and remove gas filter (17), and particulate filter (18).
- 5 If necessary for replacement, remove spring clip (18.1) from housing and precleaner (16).

**c. Cleaning**

Clean manifold assembly (15), housing and precleaner (16), gas filter (17), and particulate filter (18) with clean, damp cloth.

**d. Inspection**

- 1 Inspect housing and precleaner (16), gas filter (17), and particulate filter (18) for damage. Replace if damaged. Replacement criteria are:
  - (a) Physical and/or water damage.
  - (b) Excessive breathing resistance when M3 electrical air heaters are in use.
  - (c) Approximately 15 hours after exposure during toxic chemical operation.
  - (d) Peacetime climate replacement criteria in accordance with AR 70-38.
  - (e) Supply bulletin announcing unserviceable lot.
  - (f) When directed by supervisor.
  - (g) At beginning of combat operations where cyanogen chloride (CK) is expected.



- 2 Inspect manifold assembly (15), air outlets (2), and socket packings for damage. Replace if damaged.

**e. Assembly**

- 1 If necessary for replacement, install spring clip (18.1) on housing and precleaner (16).

**NOTE**

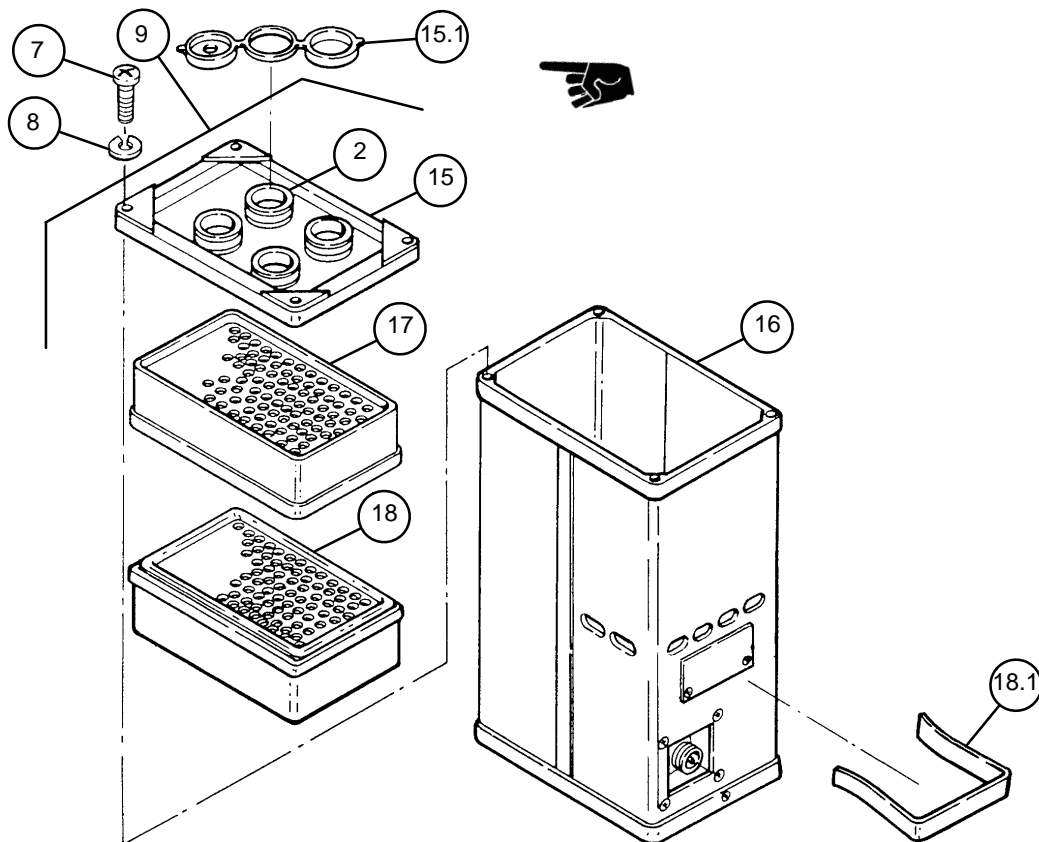
Be sure particulate filter rests against bulkhead inside housing.

- 2 Install particulate filter (18) in housing and precleaner (16) so air will flow through it in the direction of arrow marked on side of particulate filter.

**NOTE**

Be sure gasket side of gas filter is toward manifold assembly end of M2A2 air purifier.

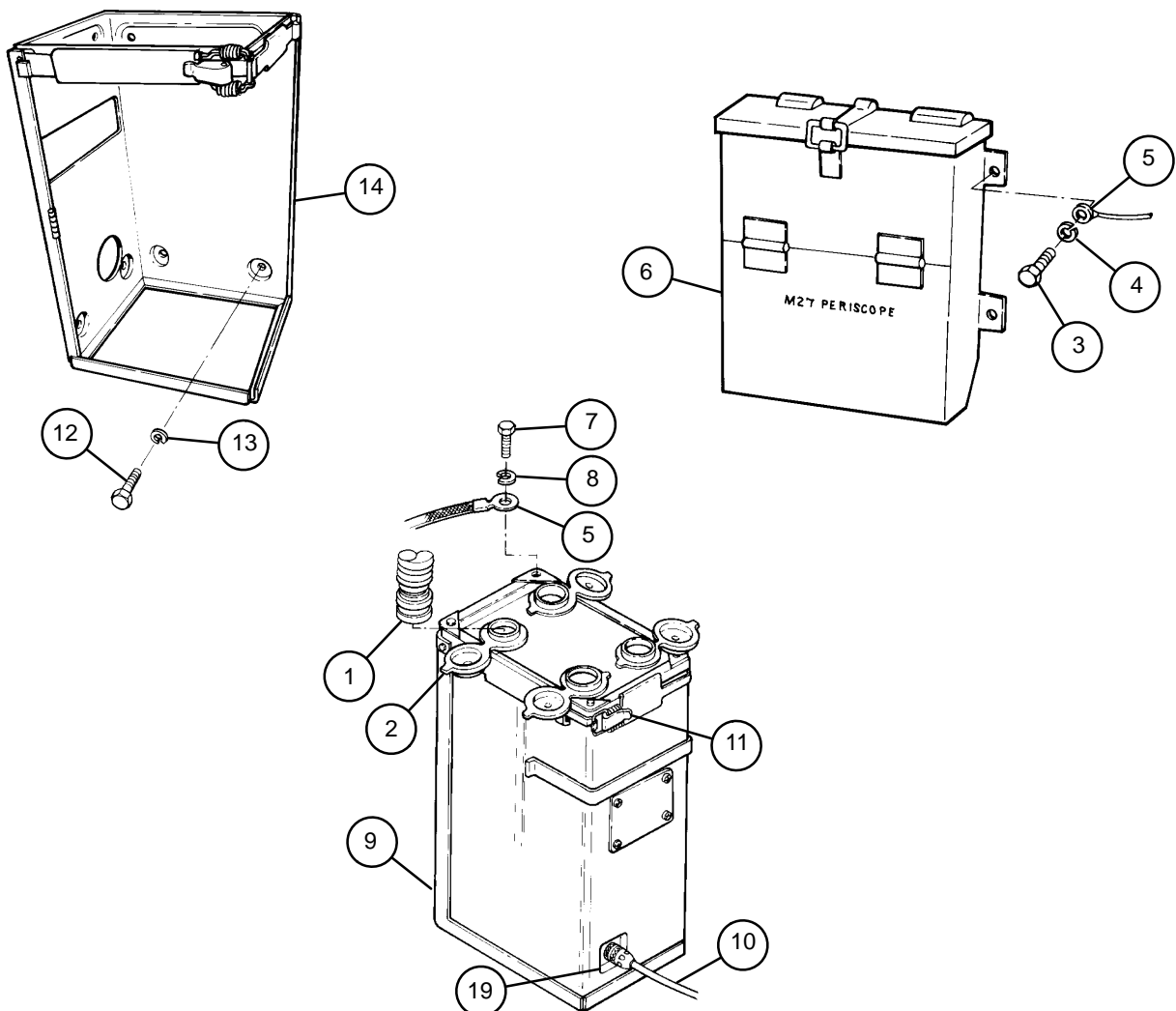
- 3 Install gas filter (17) in housing and precleaner (16) so that it rests against gasket surface of particulate filter (18).
- 4 If necessary for replacement, install four protective dust caps (15.1) on manifold assembly (15).
- 5 Install manifold assembly (15) on housing and precleaner (16) using three new lockwashers (8) and three machine screws (7).



## 17-3 M2A2 AIR PURIFIER AND BRACKET — CONTINUED

### f. Installation

- 1 Position angle bracket (14) on right front cab wall and secure with four new lockwashers (13) and four cap screws (12).
- 2 Install ground lead (5) on top of M2A2 air purifier (9) using new lockwasher (8) and machine screw (7).
- 3 Lift strap (11), install M2A2 air purifier (9) in angle bracket (14) and secure with strap.
- 4 Install remaining end of ground lead (5) at M27 periscope box (6) using new lockwasher (4) and cap screw (3).
- 5 Plug NBC power lead assembly (10) into connector (19) on lower side of M2A2 air purifier (9).
- 6 Connect four hoses (1) to air outlets (2).



## 17-4 NBC CONTROL BOX ASSEMBLY

This task covers:

a. Removal	b. Disassembly
c. Repair	d. Assembly
e. Installation	f. Testing

### INITIAL SETUP

#### Applicable Configuration

M109A4/M109A5 howitzers

#### Tools

Artillery and turret mechanic's tool kit  
(SC 5180-95-CL-A12)

#### Materials/Parts

Enamel (item 13, Appx D)  
Gasket (item 102, Appx G)  
Gasket (item 103, Appx G)

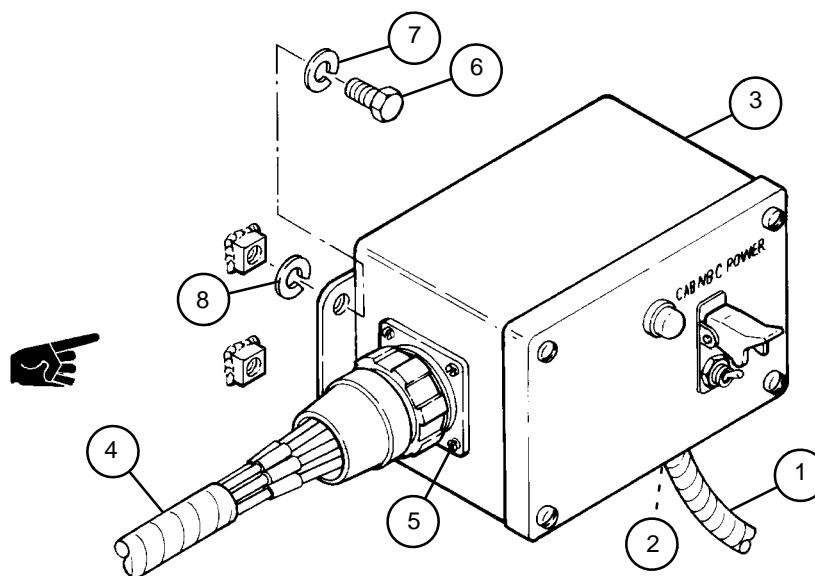
Lockwashers (4) (item 52, Appx G)  
Lockwashers (4) (item 62, Appx G)  
Lockwashers (6) (item 63, Appx G)  
Lockwashers (4) (item 64, Appx G)  
Lockwashers (4) (item 79, Appx G)  
Lockwashers (2) (item 85, Appx G)  
Packing with retainer (item 42, Appx G)

#### Equipment Condition

CAB POWER switch to OFF (TM 9-2350-311-10)  
Vehicle MASTER switch to OFF (TM 9-2350-311-10)

### a. Removal

- 1 Disconnect cab power lead assembly (1) from J1 connector (2) of distribution box (3).
- 2 Disconnect NBC power lead assembly (4) from J2 connector (5) of distribution box (3).
- 3 Remove four cap screws (6), four lockwashers (7), four lockwashers (8), and distribution box (3) from mounting blocks. Discard all lockwashers.



---

**17–4 NBC CONTROL BOX ASSEMBLY — CONTINUED**

---

**b. Disassembly****CAUTION**

Remove cover carefully to prevent damaging wires or components attached to cover.

- 1 Loosen four captive screws (9) and carefully remove cover (10).
- 2 Tag and disconnect all wires.

**NOTE**

Nut (11) and washer (12) are part of indicator light (13). Retain parts for assembly.

- 3 Remove nut (11) and washer (12) from indicator light (13) and remove indicator light, lens (14), and LED (15) from cover (10).

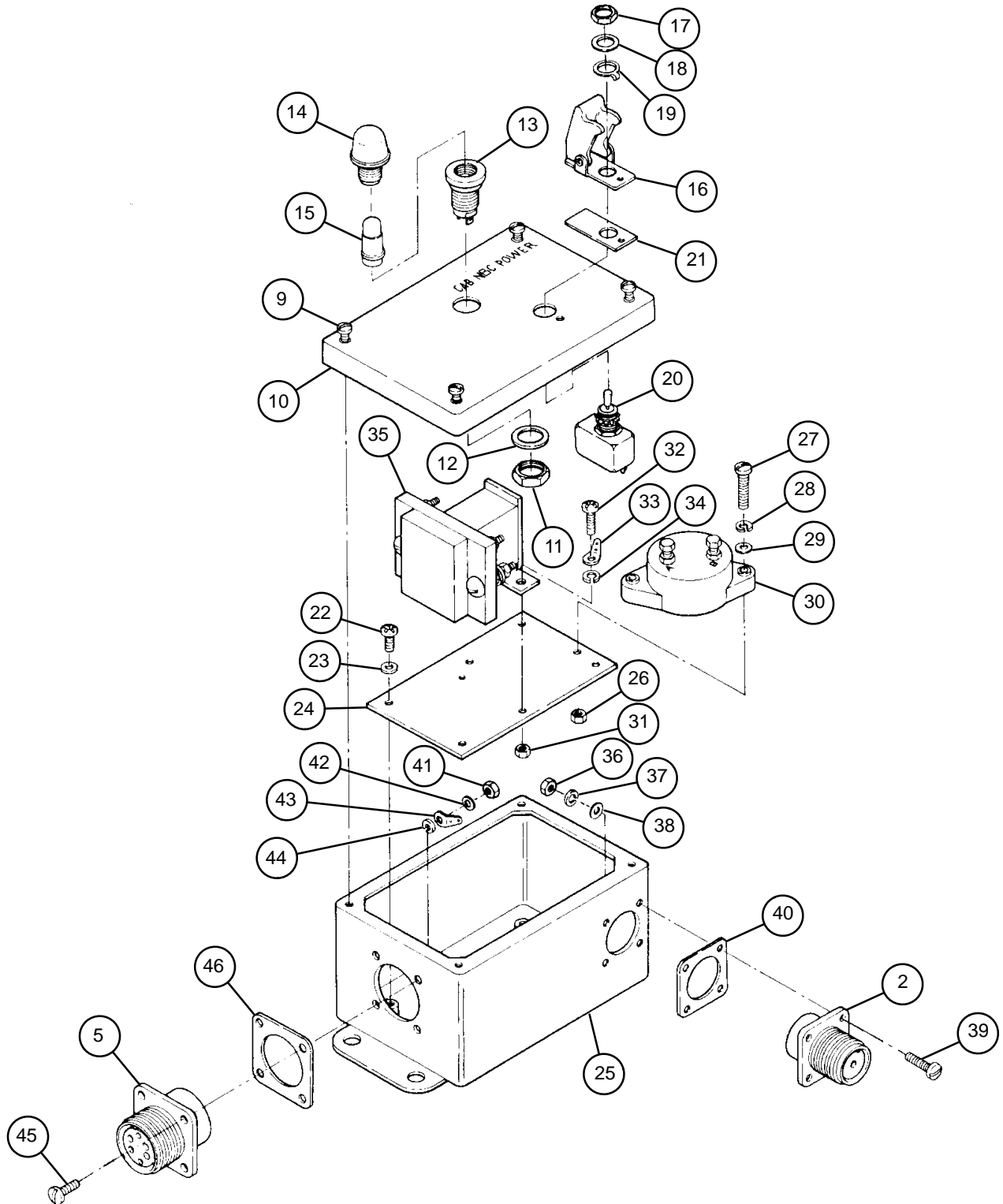
**NOTE**

Nut (17), washer (18), and locking tab (19) are part of toggle switch (20). Retain parts for assembly.

- 4 Lift switchguard (16) and remove nut (17), washer (18), and locking tab (19) to remove toggle switch (20), switchguard, and packing with retainer (21) from cover (10). Discard packing with retainer.
- 5 Disassemble four screws (22), four lockwashers (23), and mounting plate (24) and carefully remove from control box (25) with components attached. Discard lockwashers.
- 6 Remove two hex nuts (26), two machine screws (27), two lockwashers (28), two flat washers (29), and circuit breaker (30). Discard lockwashers.
- 7 Remove two hex nuts (31), two machine screws (32), lug terminal (33), two lockwashers (34), and electromagnetic relay (35). Discard lockwashers.
- 8 Remove four hex nuts (36), four lockwashers (37), four flat washers (38), four machine screws (39), J1 connector (2), and gasket (40) from bottom of control box (25). Discard gasket and lockwashers.
- 9 Remove four hex nuts (41), four flat washers (42), lug terminal (43), four lockwashers (44), four machine screws (45), J2 connector (5), and gasket (46) from side of control box (25). Discard gasket and lockwashers.

**c. Repair**

- 1 If control box (25), cover (10), inside mounting plate (24), or mounting screws (9) are damaged, replace distribution box (3).
- 2 If wires or lug terminals are damaged, replace with fabricated internal wires as necessary. Follow wiring chart and wiring diagram (para 3–3j.) for fabricating internal wires. For lug terminal repair see para 8–1.



**17-4 NBC CONTROL BOX ASSEMBLY — CONTINUED**

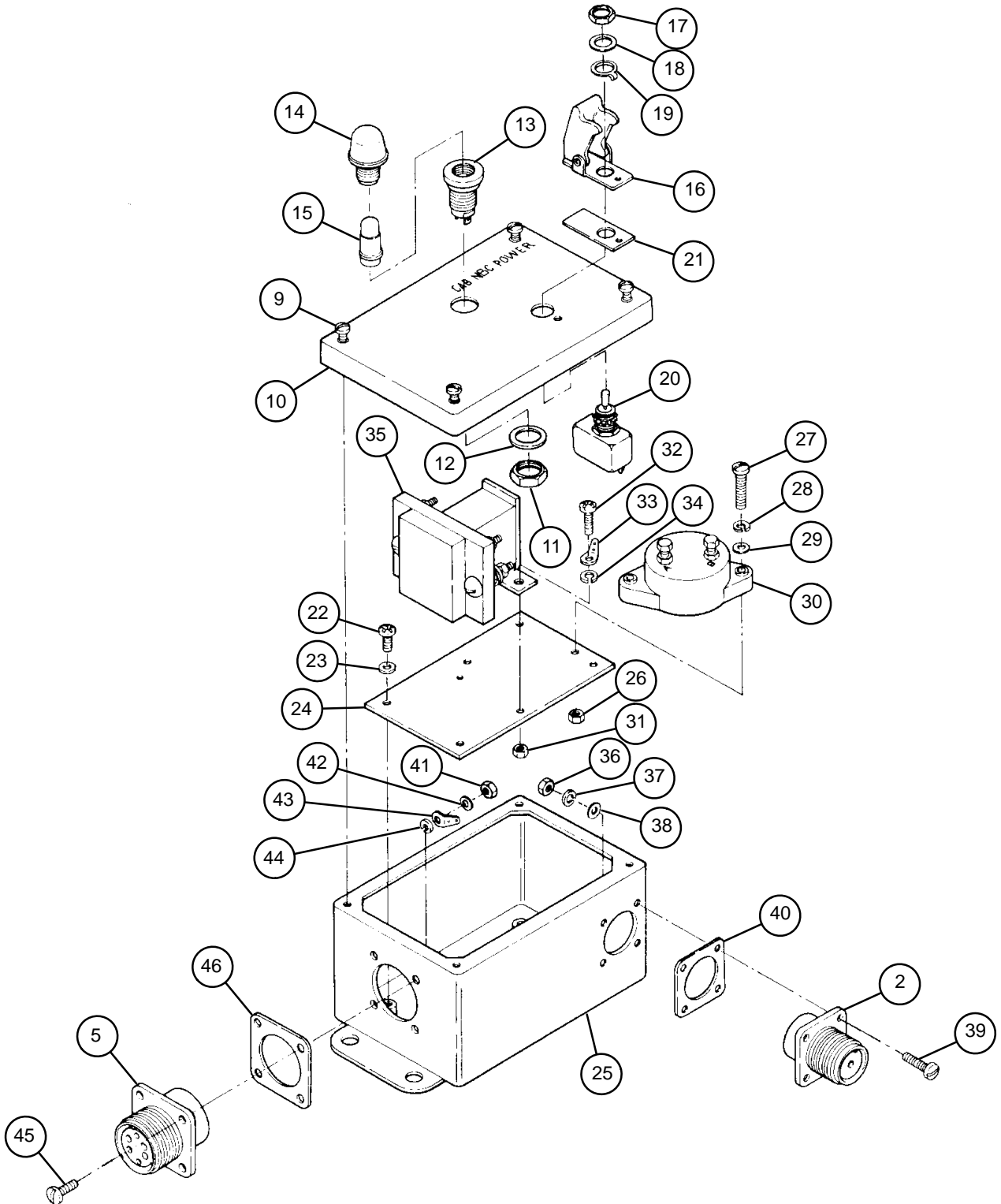
**d. Assembly**

- 29 Mount J1 connector (2) and new gasket (40) to bottom of control box (25) using four machine screws (39), four flat washers (38), four new lockwashers (37), and four hex nuts (36).
- 30 Mount J2 connector (5) and new gasket (46) to side of control box (25) using four machine screws (45), four new lockwashers (44), lug terminal (43), four flat washers (42), and four hex nuts (41).
- 31 Install circuit breaker (30) to inside mounting plate (24) using two machine screws (27), two flat washers (29), two new lockwashers (28), and two hex nuts (26).
- 32 Install electromagnetic relay (35) on inside mounting plate (24) using two machine screws (32), two new lockwashers (34), lug terminal (33) and two hex nuts (31).
- 33 Reassemble four screws (22), four new lockwashers (23), and mounting plate (24) to control box (25).
- 34 Install LED (15) and lens (14) in indicator light (13), and mount indicator light on cover (10) using washer (12) and nut (11).
- 35 Mount new packing with retainer (21), switchguard (16), and toggle switch (20) to cover (10) by aligning locking tab (19) in hole below switch hole and securing with washer (18) and nut (17).
- 36 Attach all wires and remove tags. Refer to the following wiring chart for terminal connections. See para 2-16 for soldering instructions when applicable.
- 37 After installing all wires, secure mounting screws for toggle switch (20), circuit breaker (30), J1 connector (2) and J2 connector (5) with insulating enamel.
- 38 Install cover (10) on control box (25) and tighten four captive screws (9).

WIRING CHART

ITEM	SIZE AWG	WIRE		FROM		TO		LUG TERMINAL	
		SPEC	LENGTH ±0.25	UNIT	TERM.	UNIT	TERM.	MS25036 -xxx	NO. REQD
1	6	M81044/9-6-9	5.50	J1	A	CB1	*	-120	1
2	6	M81044/9-6-9	9.50	CB1	*	K1	A2	-120,-119	1 EA
3	16	M81044/9-16-9	6.00	CB1	*	S1	2*	-106,-154	1 EA
4	20	M81044/9-20-9	5.00	DS1	*	K1	X1	-102	1
5	20	M81044/9-20-9	4.50	DS1	*	K1	X2	-102	1
6	16	M81044/9-16-9	5.00	S1	3*	K1	X2	-106	2
7	16	M81044/9-16-9	4.00	K1	X1	K1	GND	-106	1
8	14	M81044/9-14-9	5.00	J2	A	K1	A1	-108	1
9	14	M81044/9-14-9	5.00	J2	B	K1	A1	-112	1
10	14	M81044/9-14-9	5.00	J2	C	K1	A1	-112	1
11	14	M81044/9-14-9	5.00	J2	E	K1	A1	-112	1
12	14	M81044/9-14-9	5.00	J2	F	K1	A1	-112	1
13	16	M81044/9-16-9	3.50	K1	GND	J2	GND	--	--

\*Terminals on circuit breaker CB1 and LED DS1 are not designated and, thus, interchangeable. Terminal connections on switch S1 are also interchangeable.



---

## 17-4 NBC CONTROL BOX ASSEMBLY — CONTINUED

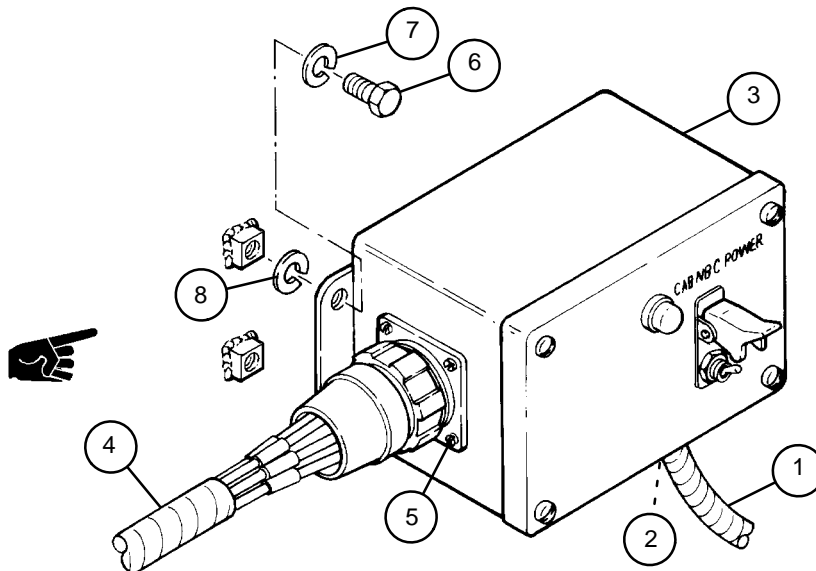
---

### e. Installation

- 1 Install distribution box (3) using four cap screws (6), four new lockwashers (7), and four new lockwashers (8).
- 2 Connect NBC power lead assembly (4) to J2 connector (5) of distribution box (3).
- 3 Connect cab power lead assembly (1) to J1 connector (2) of distribution box (3).

### f. Testing

Test operation of control box assembly by checking that NBC indicator lights and M3 air heaters work.





---

## 17-5 HOSES AND FITTINGS

---

This task covers: a. Removal b. Installation

---

### **INITIAL SETUP**

#### Applicable Configuration

M109A4/M109A5 howitzers

#### Tools

Artillery and turret mechanic's tool kit  
(SC 5180-95-CL-A12)

#### Materials/Parts

Lockwashers\* (item 64, Appx G)

Lockwashers\* (item 79, Appx G)

\*See specific legend for quantities.

---

### **a. Removal**

#### **NOTE**

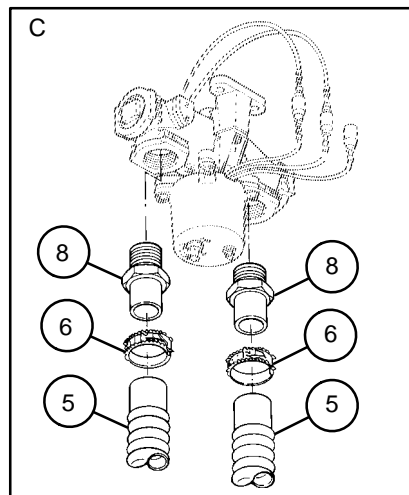
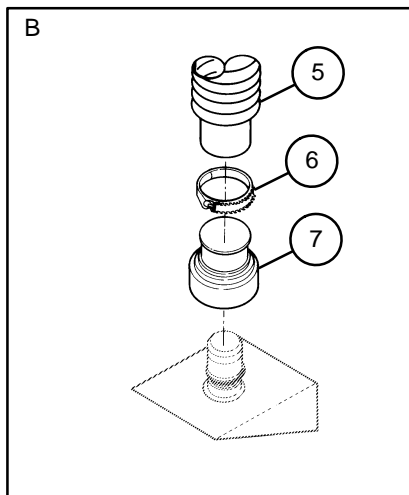
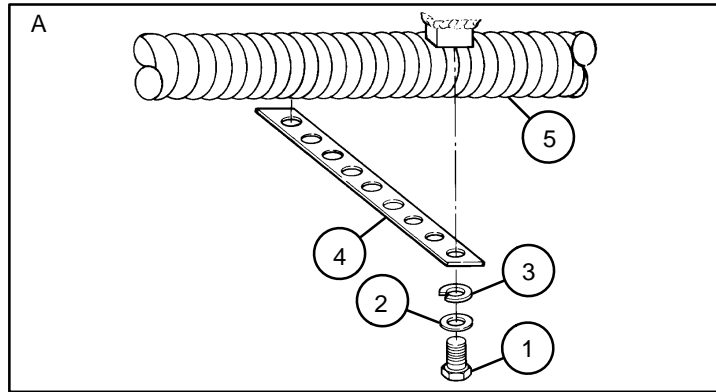
Legend identifies item, hardware quantity, and part number for each station.

For removal, follow illustration and legend as a guide.

### **b. Installation**

For installation, follow illustration and legend as a guide.

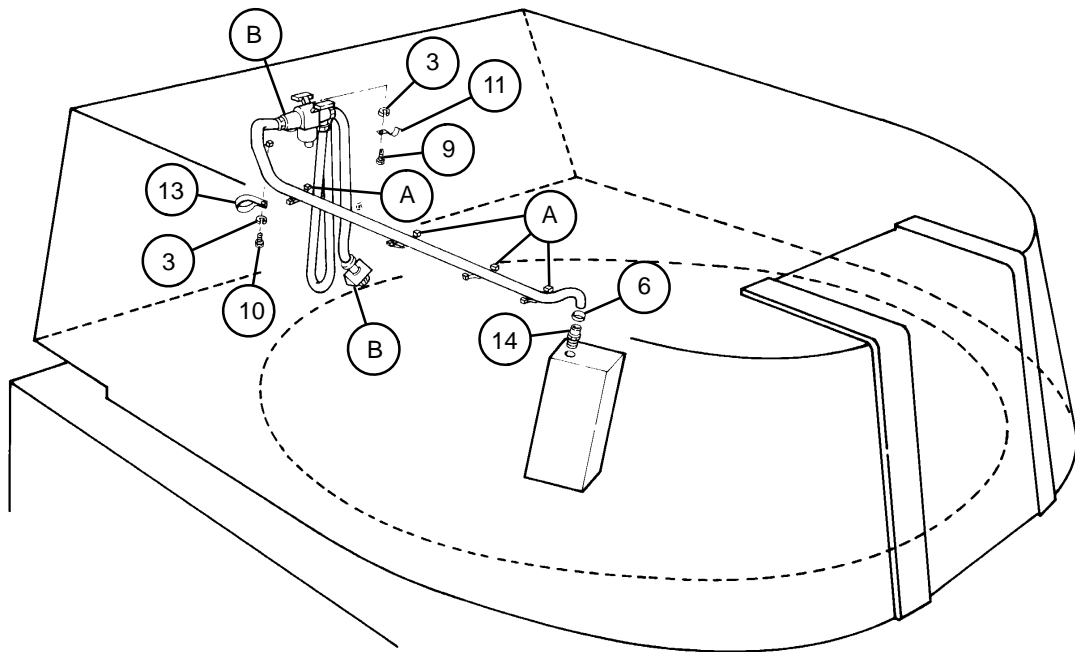
17-5 HOSES AND FITTINGS — CONTINUED



SECTION CHIEF'S STATION

LEGEND:

- |                                   |                               |
|-----------------------------------|-------------------------------|
| 1. Cap screw (4) MS90728-3        | 8. Adapter (2) B5-19-1676-2   |
| 2. Flat washer (4) MS27183-10     | 9. Cap screw (1) MS90728-6    |
| 3. Lockwasher (6) MS35338-44      | 10. Cap screw (1) MS90728-5   |
| 4. Strap (4) 10905840             | 11. Loop clamp (1) 9363627    |
| 5. Hose (2) C5-19-916-2           | 12. Lockwasher (1) MS35335-33 |
| 6. Hose clamp (4) MS22064-5       | 13. Loop clamp (1) MS9350-20  |
| 7. Coupling half (1) C5-19-1900-1 | 14. Coupling (1) 9363661      |

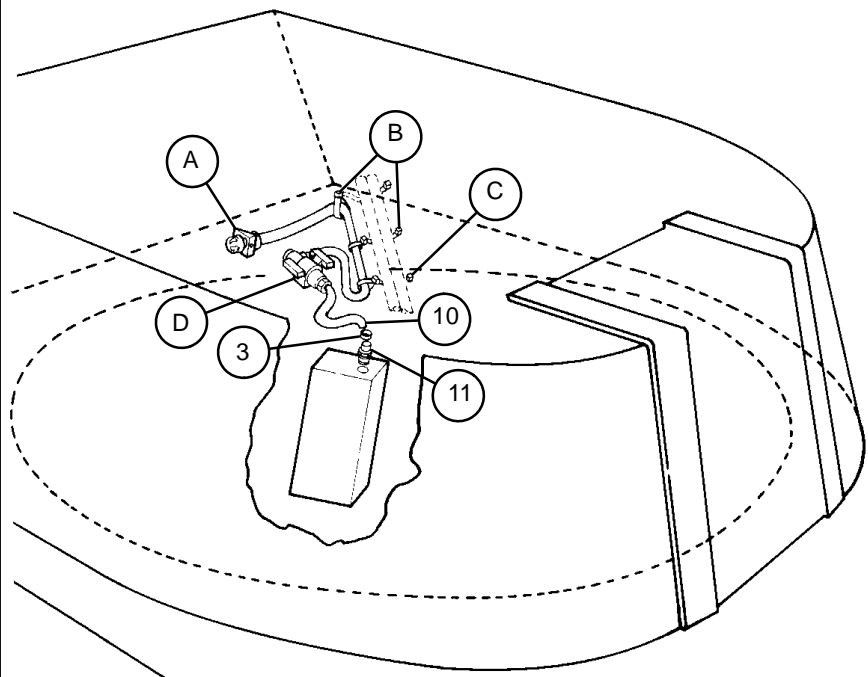
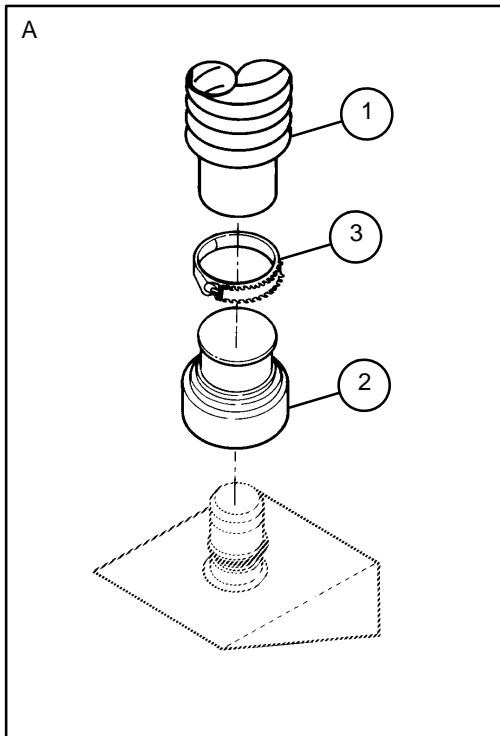


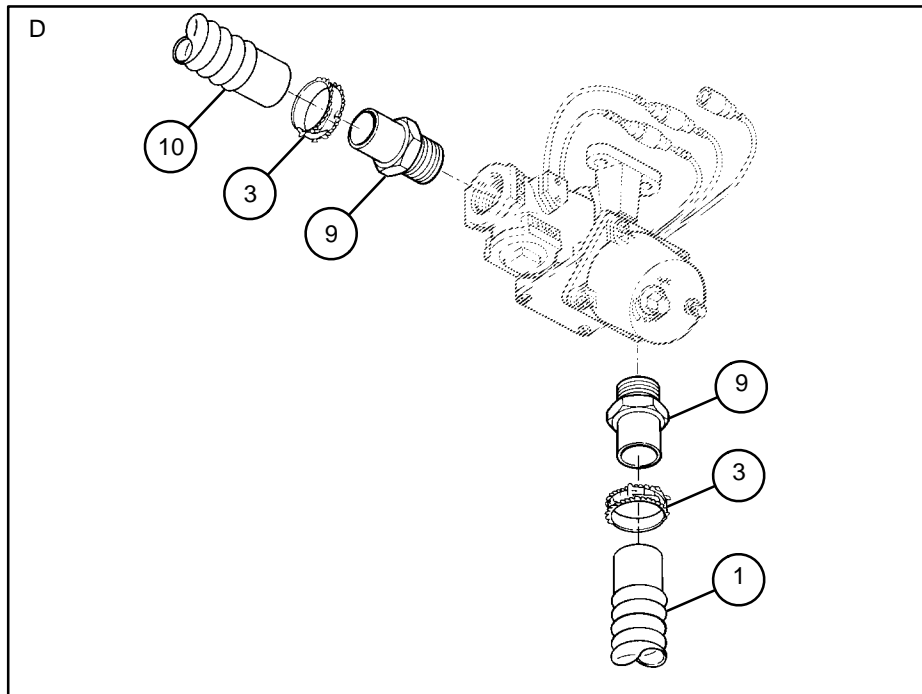
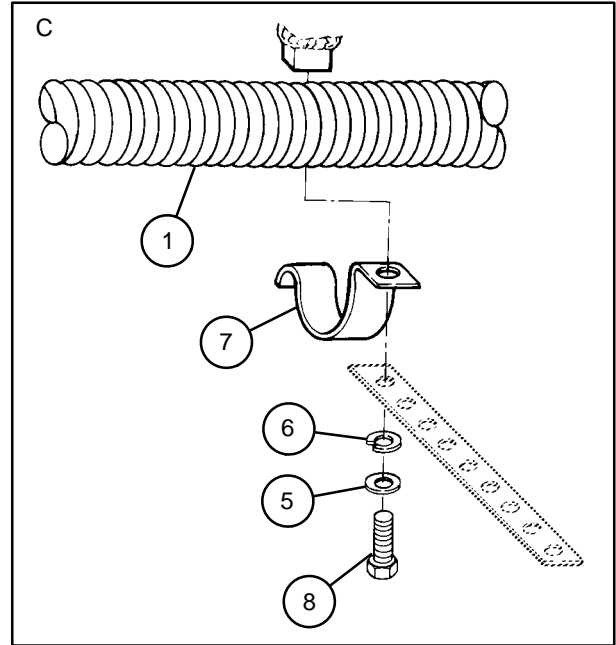
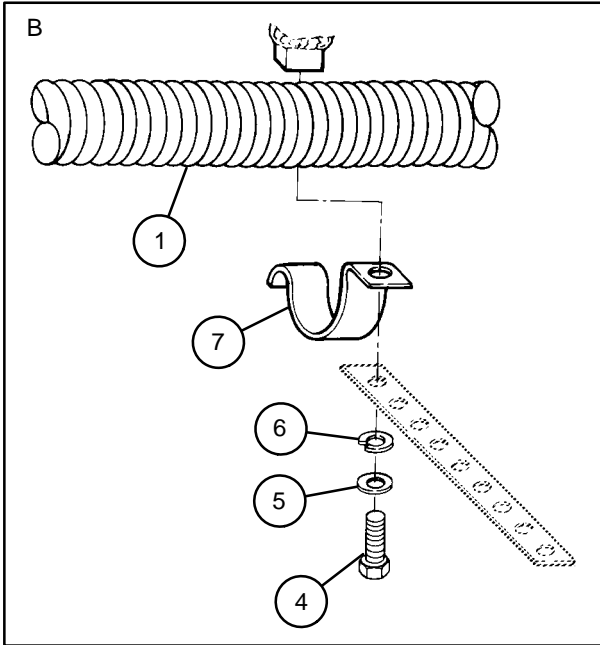
## 17-5 HOSES AND FITTINGS — CONTINUED

### ASSISTANT GUNNER'S STATION

LEGEND:

- |                                   |                             |
|-----------------------------------|-----------------------------|
| 1. Hose (1) C5-19-916-4           | 7. Loop clamp (3) 9363627   |
| 2. Coupling half (1) C5-19-1900-1 | 8. Cap screw (1) MS90728-5  |
| 3. Hose clamp (4) MS22064-5       | 9. Adapter (2) B5-19-1676-2 |
| 4. Cap screw (2) MS90728-3        |                             |
| 5. Flat washer (3) MS27183-10     | 10. Hose (1) C5-19-916-1    |
| 6. Lockwasher (3) MS35338-44      | 11. Coupling (1) 9363661    |



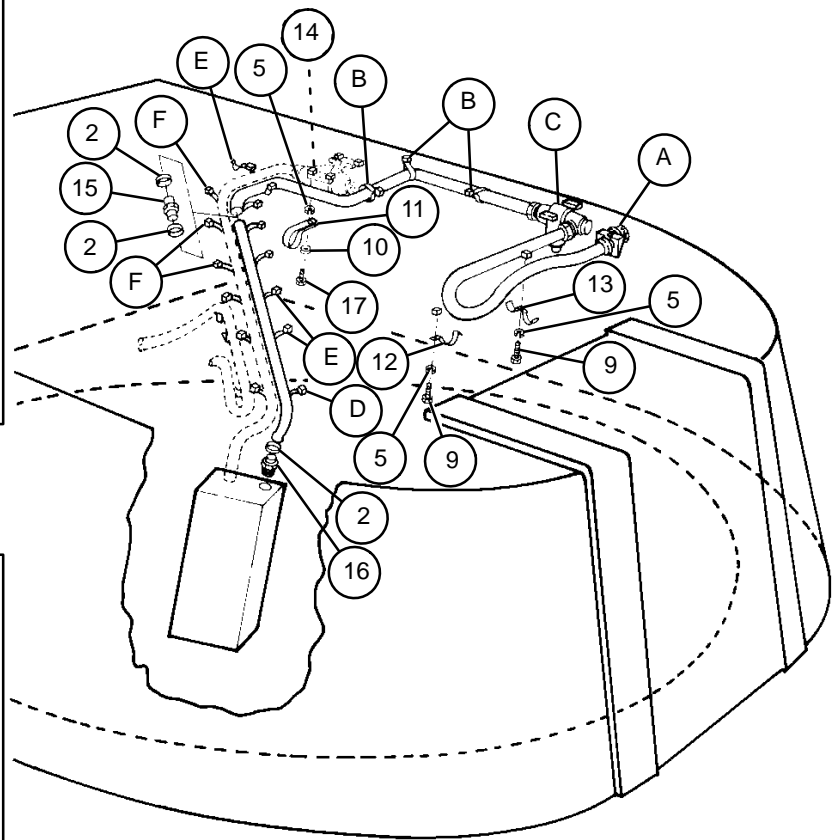
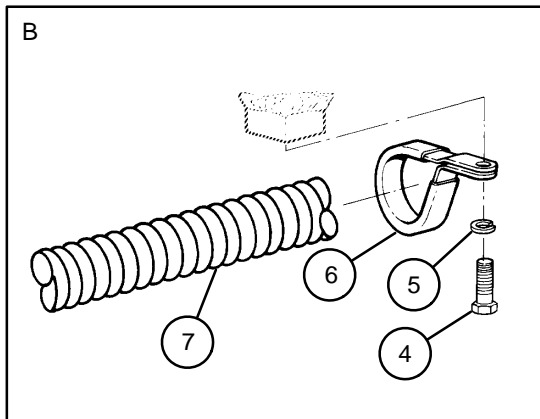
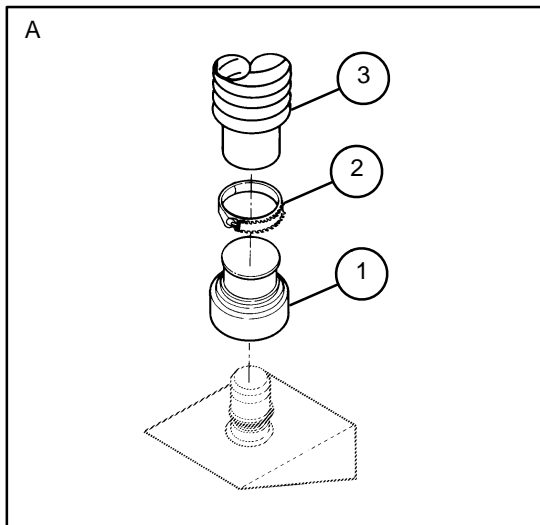


17-5 HOSES AND FITTINGS — CONTINUED

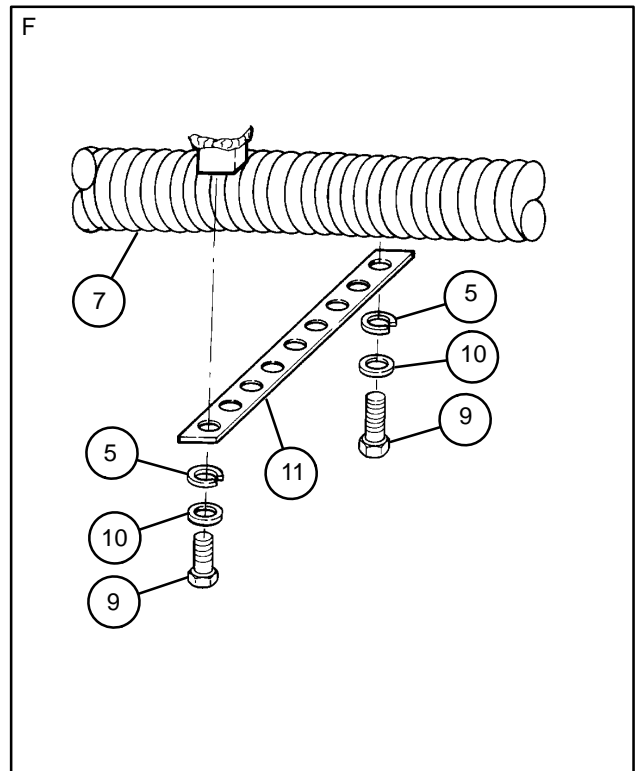
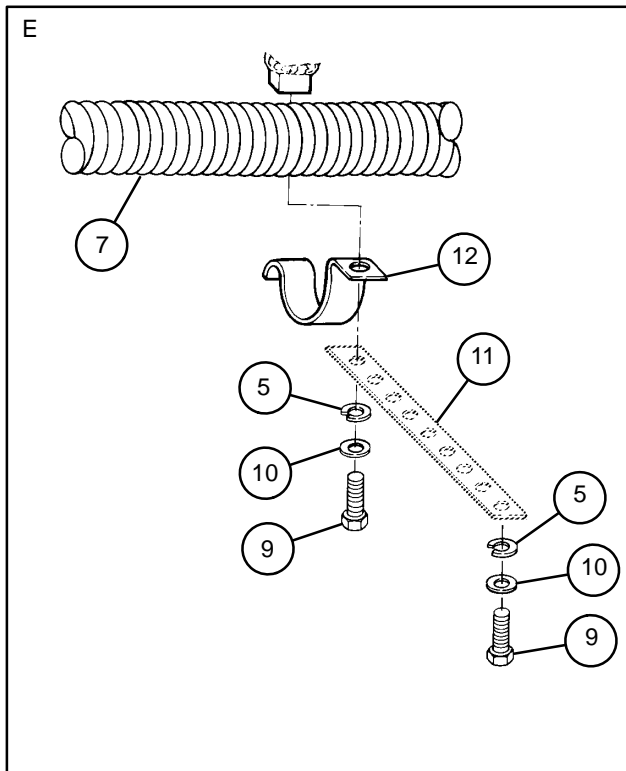
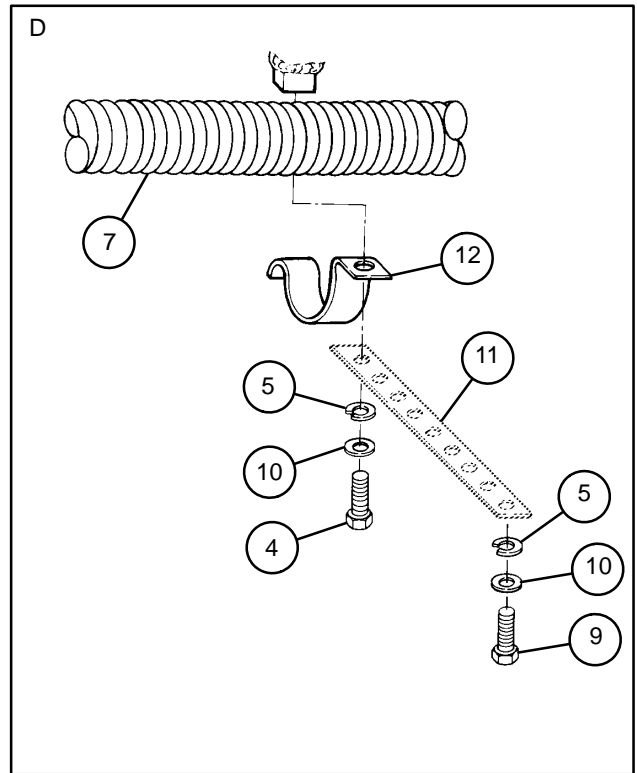
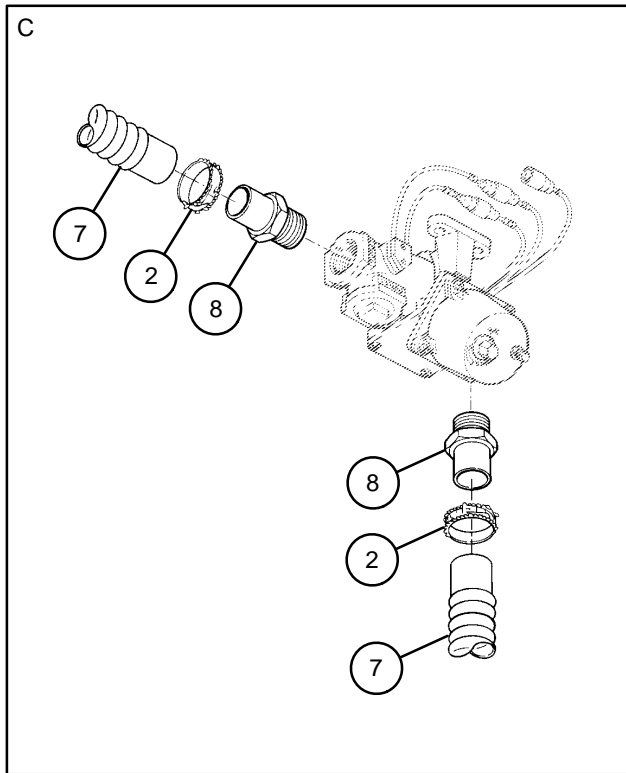
GUNNER'S STATION

LEGEND:

- |                                   |                                 |
|-----------------------------------|---------------------------------|
| 1. Coupling half (1) C5-19-1900-1 | 10. Flat washer (15) MS27183-10 |
| 2. Hose clamp (6) MS22064-5       | 11. Strap (8) 10905840          |
| 3. Hose (1) C5-19-916-4           | 12. Loop clamp (5) 9363627      |
| 4. Cap screw (4) MS90728-5        | 13. Loop clamp (1) 9363628      |
| 5. Lockwasher (20) MS35338-44     | 14. Lockwasher (1) MS35335-33   |
| 6. Loop clamp (3) MS9350-20       | 15. Tube (1) 9363632            |
| 7. Hose (2) C5-19-916-2           | 16. Coupling (1) 9363661        |
| 8. Adapter (2) B5-19-1676-2       | 17. Cap screw (1) MS90728-6     |
| 9. Cap screw (15) MS90728-3       |                                 |



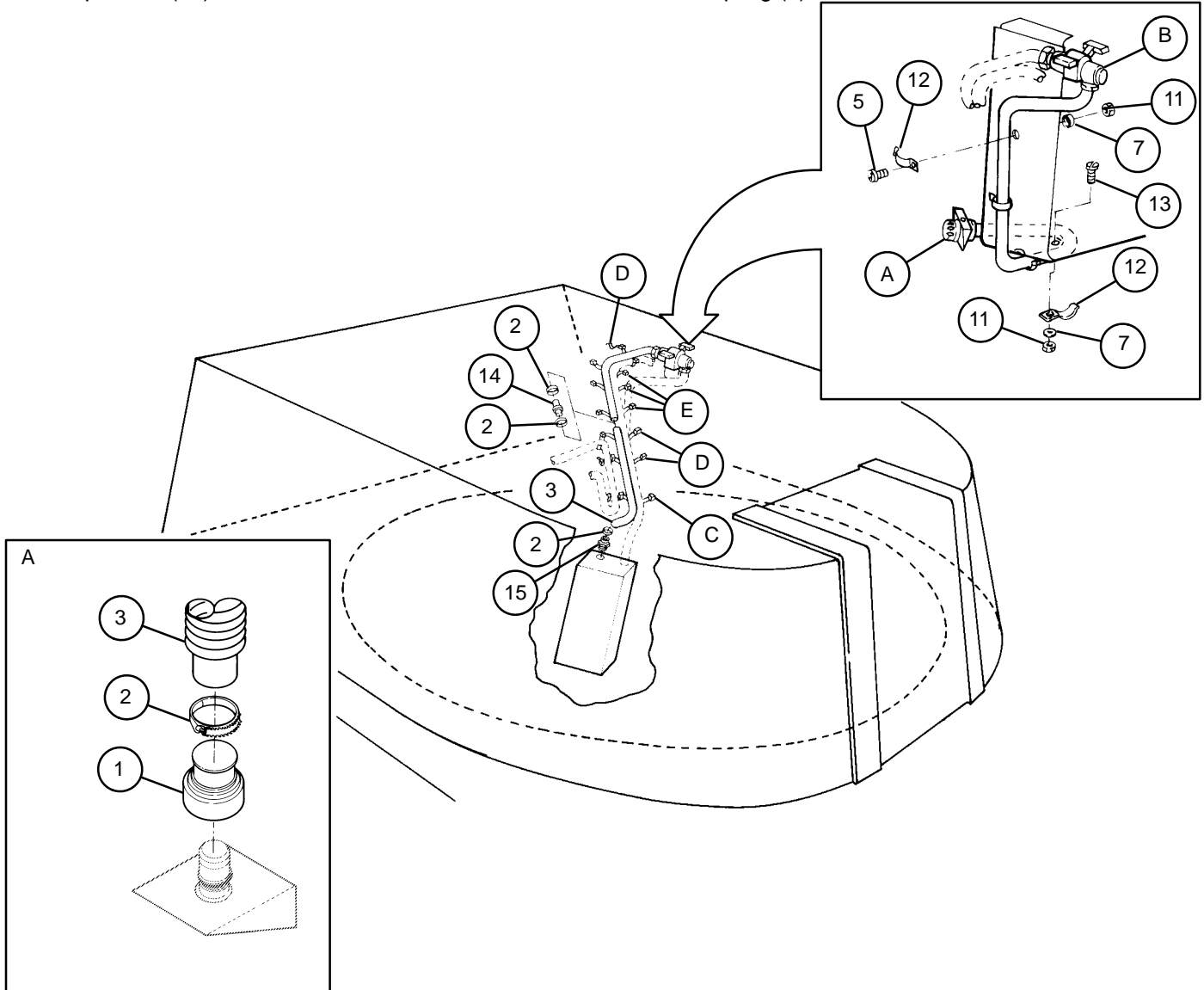
17-5 HOSES AND FITTINGS — CONTINUED



CANNONEER NO. 1'S STATION

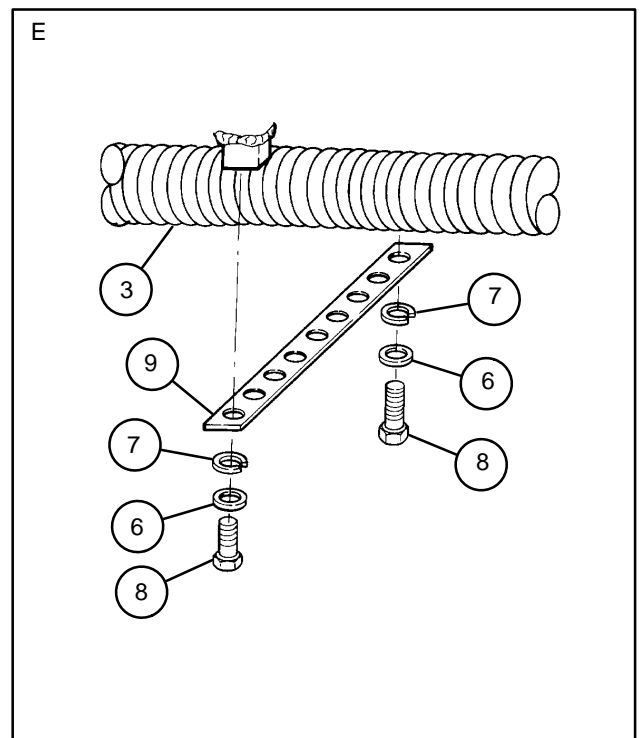
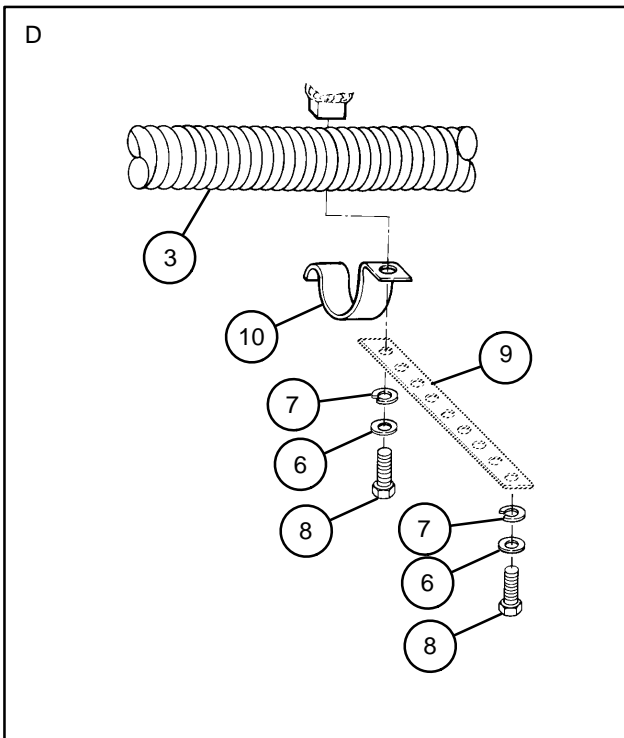
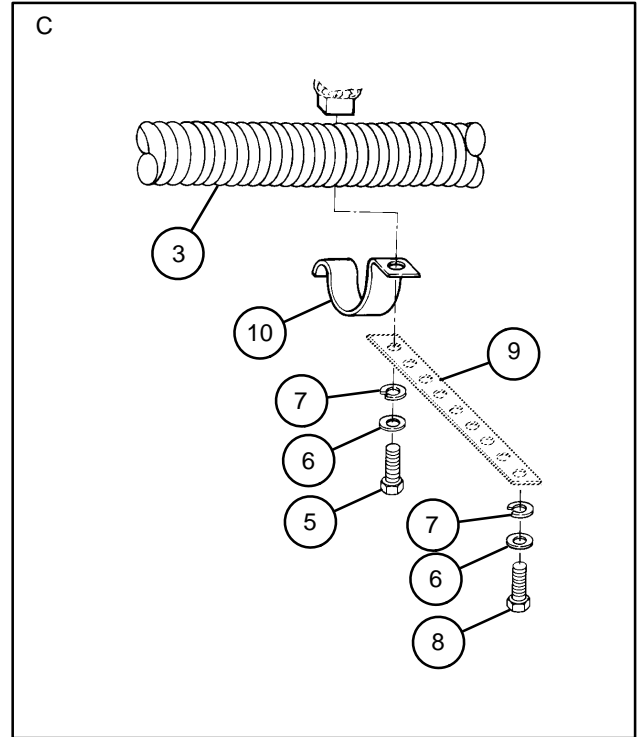
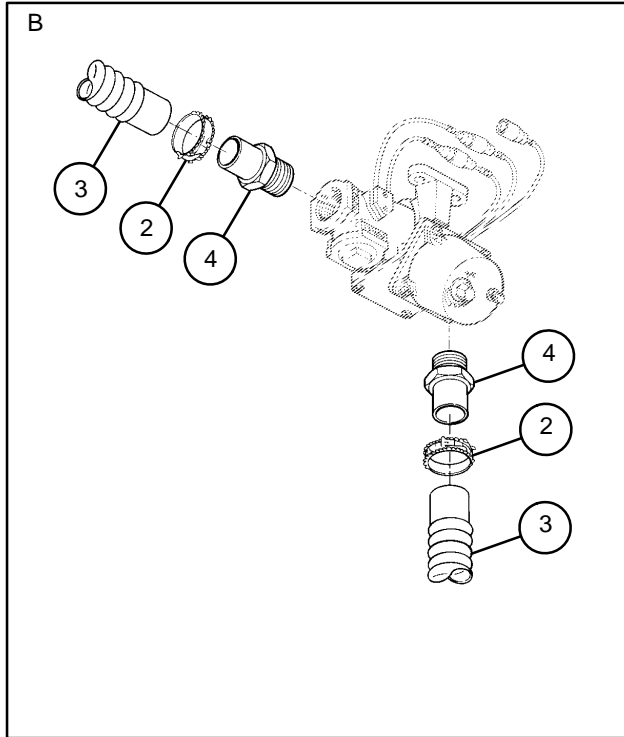
LEGEND:

- |                                      |                                  |
|--------------------------------------|----------------------------------|
| 1. Coupling half (1) C5-19-1900-1    | 9. Strap (7) 10905840            |
| 2. Hose clamp (6) MS22064-5          | 10. Loop clamp (4) 9363627       |
| 3. Hose (3) C5-19-916-4              | 11. Hex nut (4) MS51967-2        |
| 4. Straight adapter (2) B5-19-1676-2 | 12. Loop clamp (4) 9363631       |
| 5. Cap screw (3) MS90728-5           | 13. Machine screw (2) MS51959-81 |
| 6. Flat washer (14) MS27183-10       | 14. Tube (1) 9363632             |
| 7. Lockwasher (18) MS35338-44        | 15. Coupling (1) 9363661         |



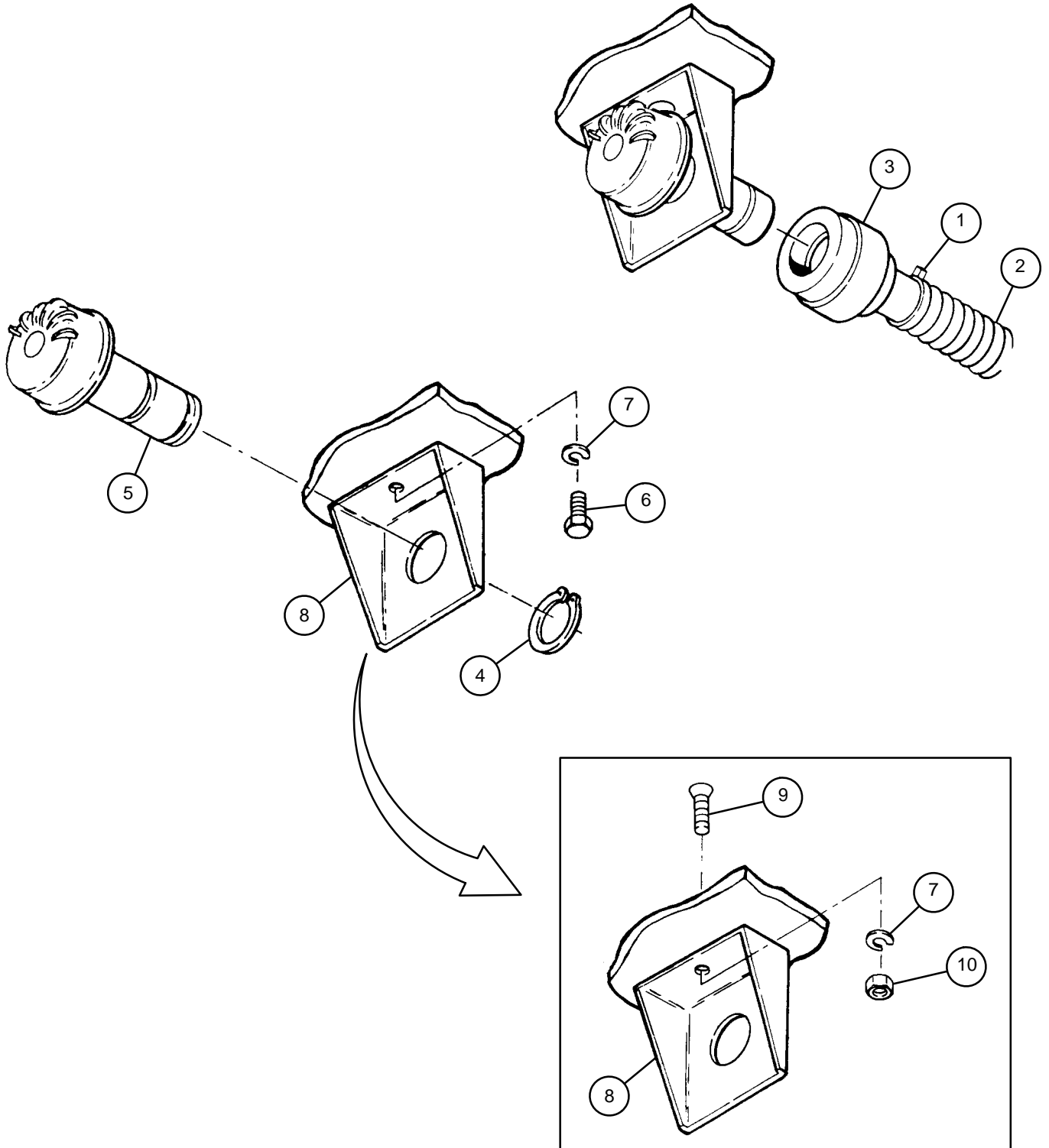


17-5 HOSES AND FITTINGS — CONTINUED





17-7 AIR OUTLET ORIFICE CONNECTOR



CANNONEER NO 1's STATION

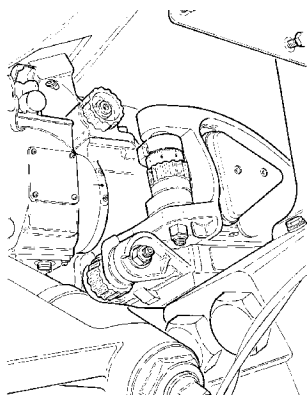


## CHAPTER 18 FIRE CONTROL

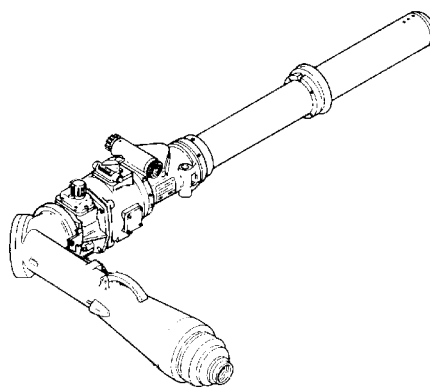
### GENERAL

This chapter illustrates and describes maintenance procedures for sighting and fire control equipment. The chapter gives inspection, repair, replacement and adjustment procedures assigned to unit maintenance by Appendix B, Maintenance Allocation Chart.

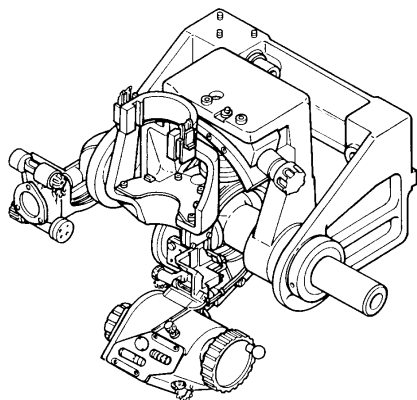
CONTENTS	Page
18-1 M146 TELESCOPE MOUNT .....	18-3
18-2 M118A2/M118A3 ELBOW TELESCOPE .....	18-6
18-3 M145/M145A1 TELESCOPE MOUNT .....	18-8
18-4 M145/M145A1 TELESCOPE MOUNT: SYNCHRONIZATION AND ADJUSTMENT .....	18-18
18-5 M117/M117A2 PANORAMIC TELESCOPE .....	18-30
18-6 M15 ELEVATION QUADRANT .....	18-32
18-7 M42 TANK PERISCOPE .....	18-35



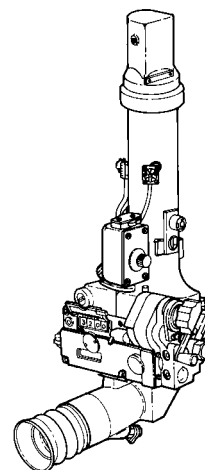
M146 TELESCOPE MOUNT



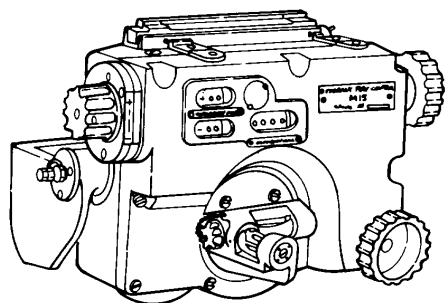
M118A2/M118A3 ELBOW TELESCOPE



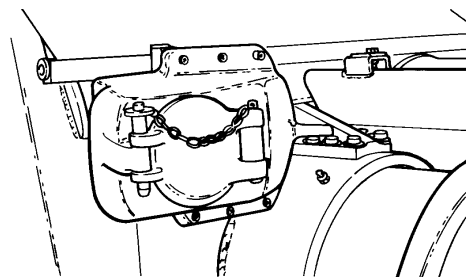
M145/M145A1 TELESCOPE MOUNT



M117/M117A2 PANORAMIC TELESCOPE



M15 ELEVATION QUADRANT



M42 TANK PERISCOPE

## 18-1 M146 TELESCOPE MOUNT

- This task covers:
- |                 |               |
|-----------------|---------------|
| a. Removal      | b. Inspection |
| c. Disassembly  | d. Assembly   |
| e. Installation |               |

### INITIAL SETUP

Tools

Artillery and turret mechanic's tool kit  
(SC 5180-95-CL-A12)

Lockwashers (8) (item 73, Appx G)

References

TM 9-2350-311-10

Materials/Parts

Lockwashers (2) (item 59, Appx G)

Lockwashers (2) (item 70, Appx G)

Lockwashers (3) (item 71, Appx G)

Equipment Condition

M118A2/M118A3 elbow telescope removed  
(TM 9-2350-311-10)

#### a. Removal

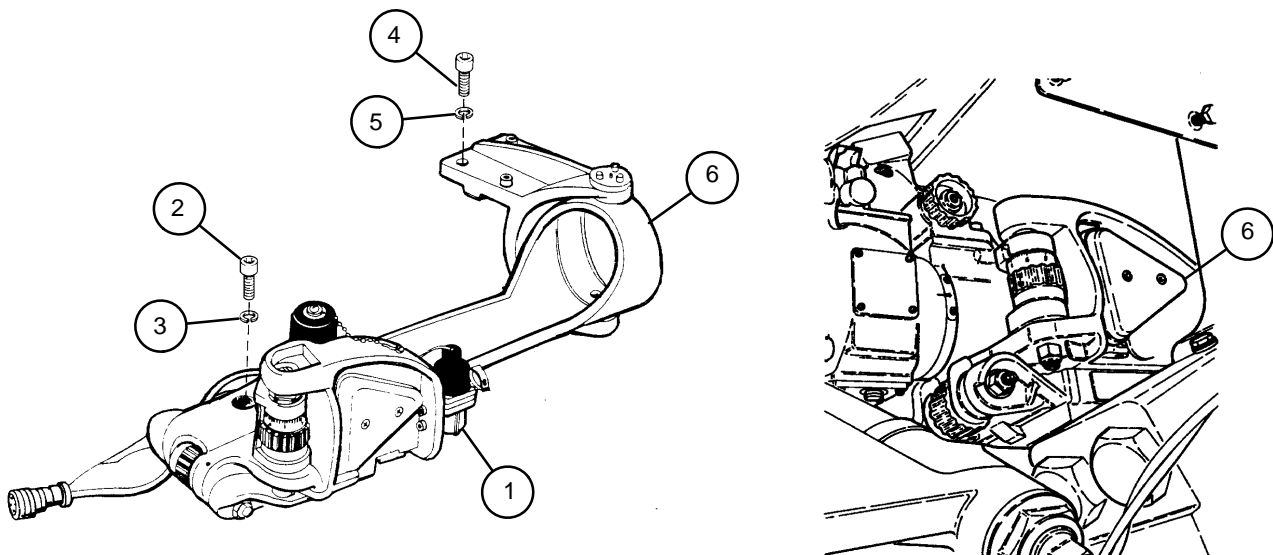
#### NOTE

For removal or installation of M146 telescope mount, elevate cannon to 800 mils.

- 1 Disconnect cab electrical connector from mount receptacle (1).
- 2 Remove four cap screws (2) and four lockwashers (3). Discard lockwashers.
- 3 Remove four cap screws (4) and four lockwashers (5). Discard lockwashers.
- 4 Lift off M146 telescope mount (6).

#### b. Inspection

For inspection refer to TM 9-2350-311-10.



## 18–1 M146 TELESCOPE MOUNT — CONTINUED

---

### c. Disassembly

- 1 Remove two machine screws (7) and two lockwashers (8). Discard lockwashers.
- 2 Remove chain assembly (9).
- 3 Remove three machine screws (10) and three lockwashers (11) to free three clamps (12) from elevation slide (13). Discard lockwashers.
- 4 Remove cable assembly (14) by removing two cap screws (15) and two lockwashers (16). Discard lockwashers.

### d. Assembly

- 1 Install cable assembly (14) to M146 telescope mount (6) with two cap screws (15) and two new lockwashers (16).
- 2 Secure three clamps (12) to elevation slide (13) with three new lockwashers (11) and three machine screws (10).
- 3 Assemble chain assembly (9) to M146 telescope mount (6) with machine screw (7) and new lockwasher (8).
- 4 Connect other end of chain assembly (9) to knob with other machine screw (7) and new lockwasher (8).

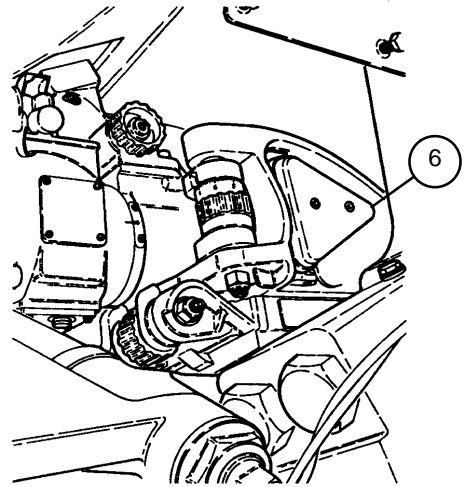
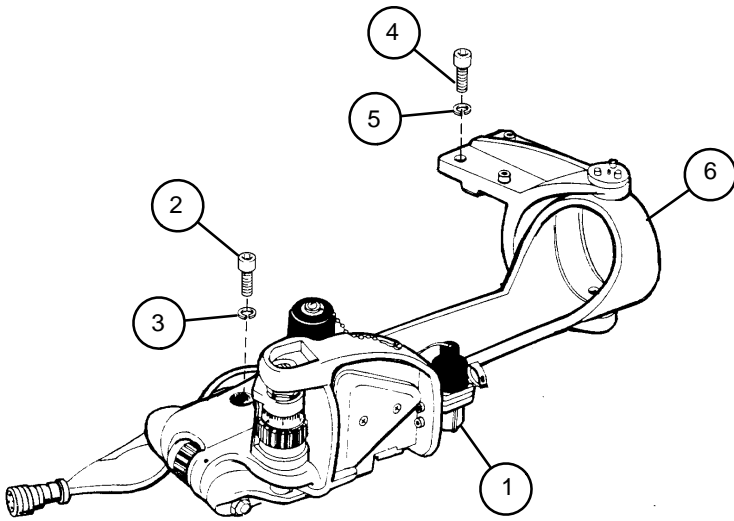
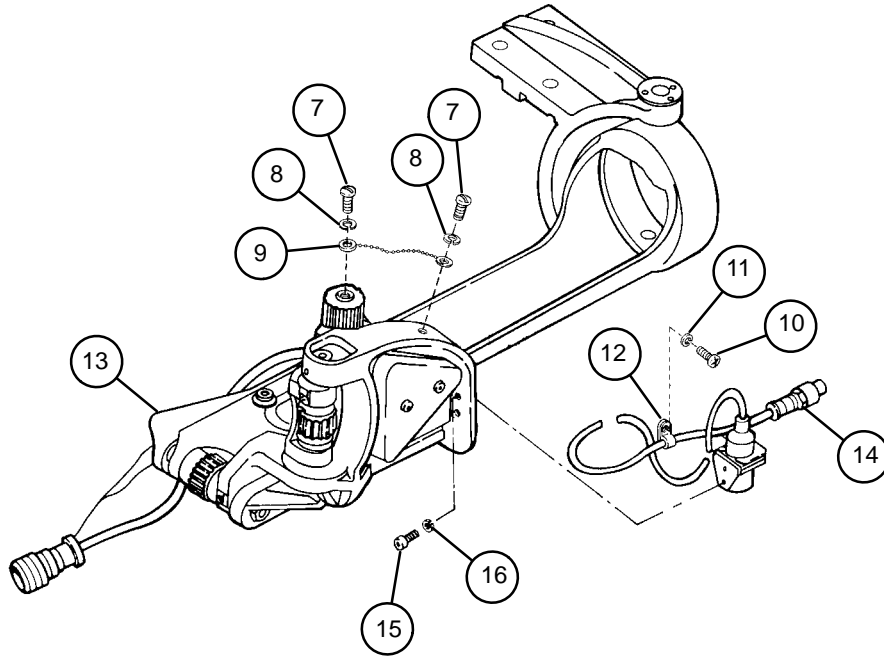
### e. Installation

#### NOTE

Clean mating surfaces of M146 telescope mount and brackets on howitzer mount to ensure proper installation. Seat key securely at front of M146 telescope mount.

- 1 Aline eight holes on M146 telescope mount (6) with eight holes on cab.
- 2 Install four new lockwashers (5) and four cap screws (4).
- 3 Install four new lockwashers (3) and four cap screws (2).
- 4 Connect cab electrical connector to mount receptacle (1).





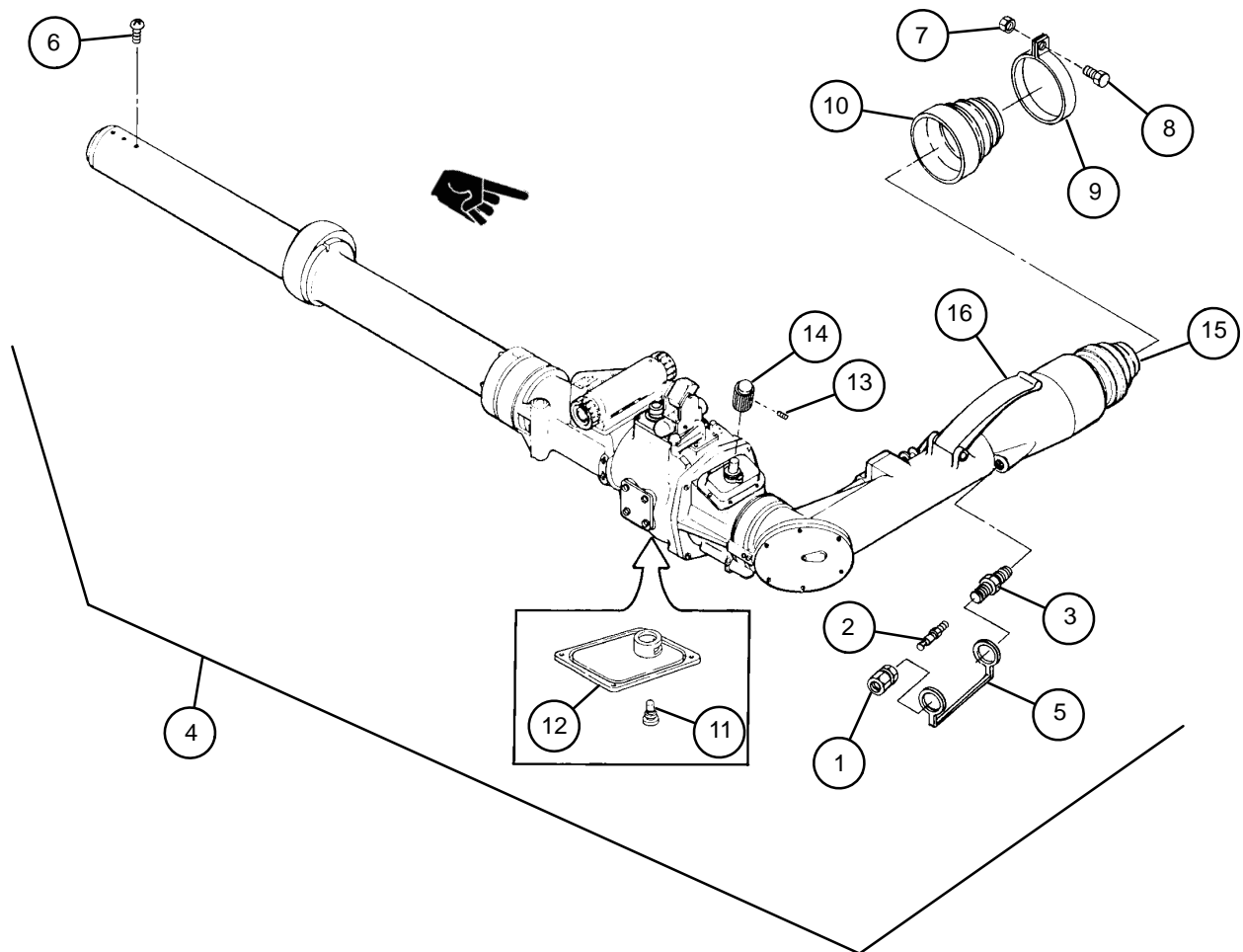


- 3 Install machine screw (6) to exit port.
- 4 Position strap (5) on purging valve stem (3). Apply sealing compound to threads of purging valve stem then screw into M118A2/M118A3 elbow telescope (4).
- 5 Install valve core (2) to purging valve stem (3) and air valve cap (1) to strap (5).
- 6 Install air valve cap (1) on purging valve stem (3).
- 7 Install lamp (11) in access cover (12) of M118A2 elbow telescope only.
- 8 Install knob (14) and setscrew (13).

**NOTE**

Nitrogen charge was released when valve core and exit port machine screw were removed.

- 9 Purge and charge (TM 750-116).



---

## 18-3 M145/M145A1 TELESCOPE MOUNT

---

- This task covers:
- |  |  |
|--|--|
| a. Inspection of M145/M145A1 Telescope Mount | b. Removal of M145/M145A1 Telescope Mount      |
| c. Disassembly of Linkage Assembly           | d. Inspection of Linkage Assembly              |
| e. Assembly of Linkage Assembly              | f. Disassembly of Level Assembly               |
| g. Assembly of Level Assembly                | h. Disassembly of Disk Assembly                |
| i. Assembly of Disk Assembly                 | j. Disassembly of Quadrant Support Assembly    |
| k. Assembly of Quadrant Support Assembly     | l. Disassembly of Counter Box Assembly         |
| m. Assembly of Counter Box Assembly          | n. Installation of M145/M145A1 Telescope Mount |
- 

### **INITIAL SETUP**

#### Tools

Artillery and turret mechanic's tool kit  
(SC 5180-95-CL-A12)  
Torque wrench (item 18, Appx H)

#### Materials/Parts

Lockwasher (item 82, Appx G)  
Lockwashers (5) (item 58, Appx G)  
Lockwashers (4) (item 74, Appx G)  
Lockwashers (4) (item 83, Appx G)  
Lockwashers (4) (item 96, Appx G)

Self-locking nuts (2) (item 181, Appx G)  
Webbing strap (item 35, Appx D)

#### Personnel Required

2

#### References

TM 9-2350-311-10  
TM 750-116

#### Equipment Condition

M117/M117A2 panoramic telescope removed  
(TM 9-2350-311-10)

---

#### **a. Inspection of M145/M145A1 Telescope Mount**

For inspection refer to TM 9-2350-311-10.

#### **b. Removal of M145/M145A1 Telescope Mount**

### **WARNING**

M145/M145A1 telescope mount weighs 96 pounds (43.5 kg). Observe caution when lifting to prevent bodily injury or equipment damage.

#### **NOTE**

Mark lower gun arm caps before removal. Lower gun arm caps must be installed in same position from which they were removed.

- 1 Remove four cap screws (1), four lockwashers (2), and two lower gun arm caps (3). Discard lockwashers.
- 2 Loosen four cap screws (4) securing linkage assembly (5) to M145/M145A1 telescope mount (6).

#### **NOTE**

After loosening four cap screws, you may have to tap arm with a soft faced hammer to release gripsprings located between plates.

- From inside cab, reach between M145/M145A1 telescope mount (6) and roof of cab, and disconnect electrical connector (7) located on upper left side of M145/M145A1 telescope mount.

**NOTE**

For ease of assembly, do not allow lower assembly of linkage assembly to rotate.

- Remove linkage assembly (5) from M145/M145A1 telescope mount (6).

**NOTE**

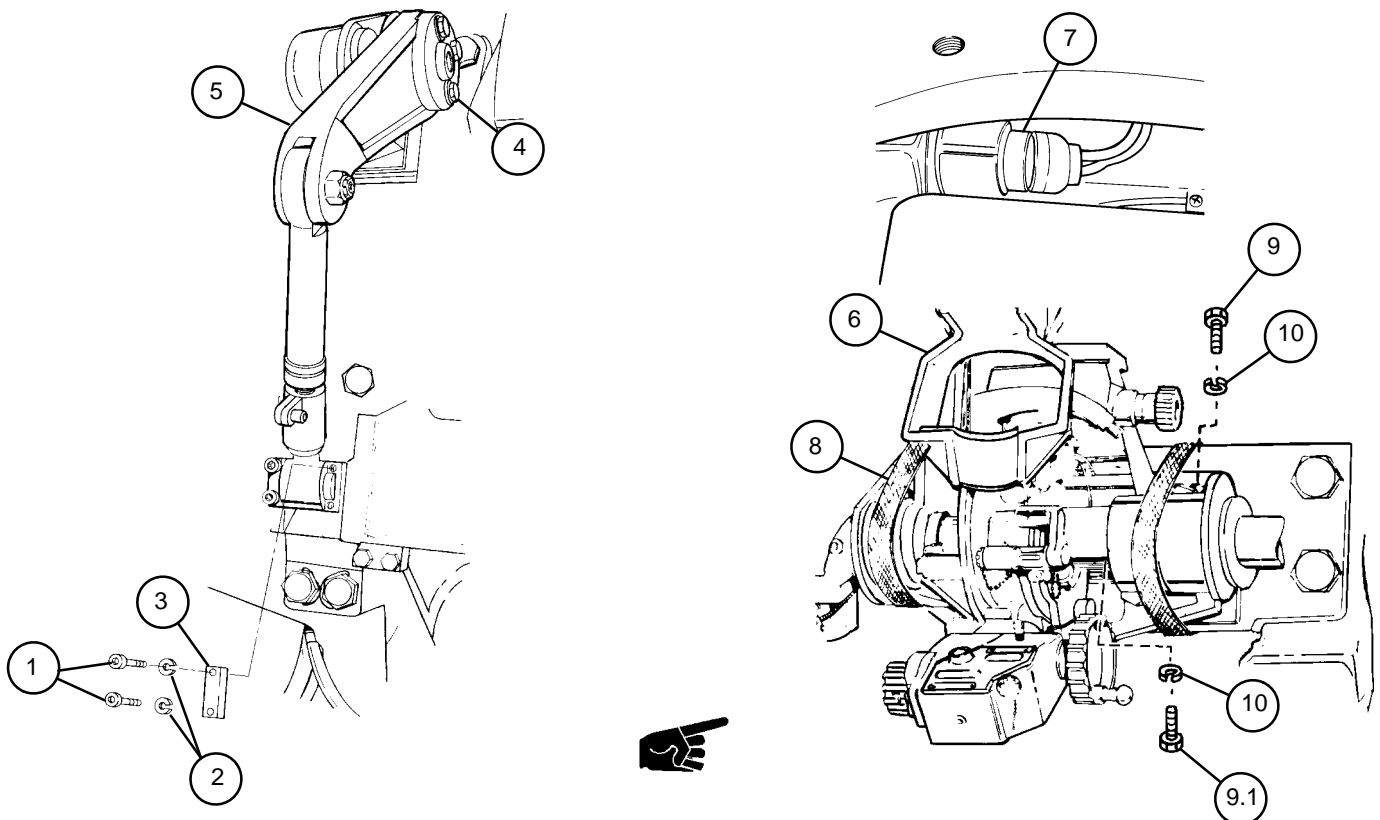
Webbing strap must be used to help hold M145/M145A1 telescope mount in keyway until all cap screws are removed.

- Support M145/M145A1 telescope mount (6) with webbing strap (8) around M145/M145A1 telescope mount and mounting plate (not shown). Loosen two cap screws (9) and two cap screws (9.1), but leave enough of the threads holding to support M145/M145A1 telescope mount.

**WARNING**

M145/M145A1 telescope mount weighs 96 pounds (43.5 kg). The following steps require two personnel to prevent bodily injury or equipment damage.

- Hold M145/M145A1 telescope mount (6) in mounting plate keyway (hidden) and remove two cap screws (9), two cap screws (9.1), and four lockwashers (10). Discard lockwashers.
- While securely holding M145/M145A1 telescope mount (6) in keyway of mounting plate (hidden), remove webbing strap (8).
- Carefully lower M145/M145A1 telescope mount (6) to floor of cab.



## 18–3 M145/M145A1 TELESCOPE MOUNT — CONTINUED

---

### c. Disassembly of Linkage Assembly

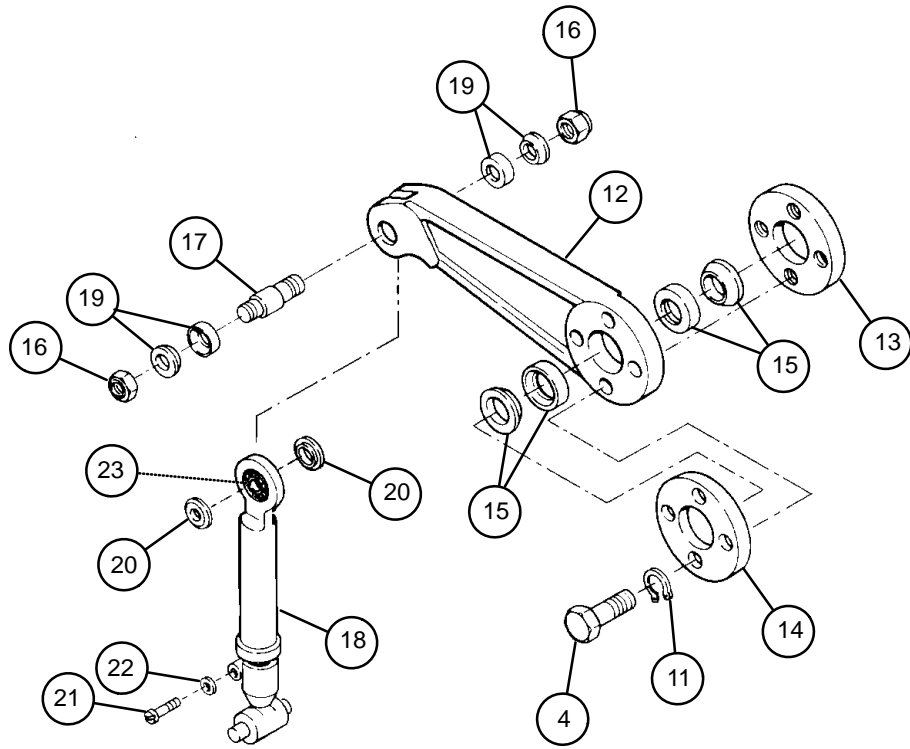
- 1 Remove four cap screws (4) and four lockwashers (11) from arm (12). Discard lockwashers.
- 2 Remove plate (13), plate (14), and two gripspring sets (15) (four gripsprings).
- 3 Remove two self-locking nuts (16) from shouldered shaft (17). Using brass drift punch and hammer, tap shouldered shaft from arm (12). Discard self-locking nuts.
- 4 Separate arm (12) from link (18) and remove two gripspring sets (19) (four gripsprings), and two washer bearings (20).
- 5 At bottom of link (18), remove cap screw (21) and lockwasher (22). Discard lockwasher.

### d. Inspection of Linkage Assembly

- 1 Inspect gripsprings (15 and 19) for evidence of spinning. Replace if defective.
- 2 If plate (13) shows evidence of being dented or bent, replace.
- 3 Inspect all threaded parts for stripped or missing threads. Replace as needed.

### e. Assembly of Linkage Assembly

- 1 Install two washer bearings (20) with the raised portion against ball bearing (23).
- 2 Install bottom link (18) into arm (12).
- 3 Insert shouldered shaft (17) into arm (12), and tap into place using brass drift punch and hammer.
- 4 Install two gripspring sets (19) with the flat sides of the external springs positioned against washer bearings (20) and internal springs towards self-locking nut. Install two new self-locking nuts (16).
- 5 Install new lockwasher (22) and cap screw (21) at bottom of link (18).
- 6 Install two gripspring sets (15) in arm (12) with the flat sides of the external halves together.
- 7 Place plate (13) on arm (12) and plate (14) on the opposite side of arm.
- 8 Install four new lockwashers (11) and four cap screws (4).



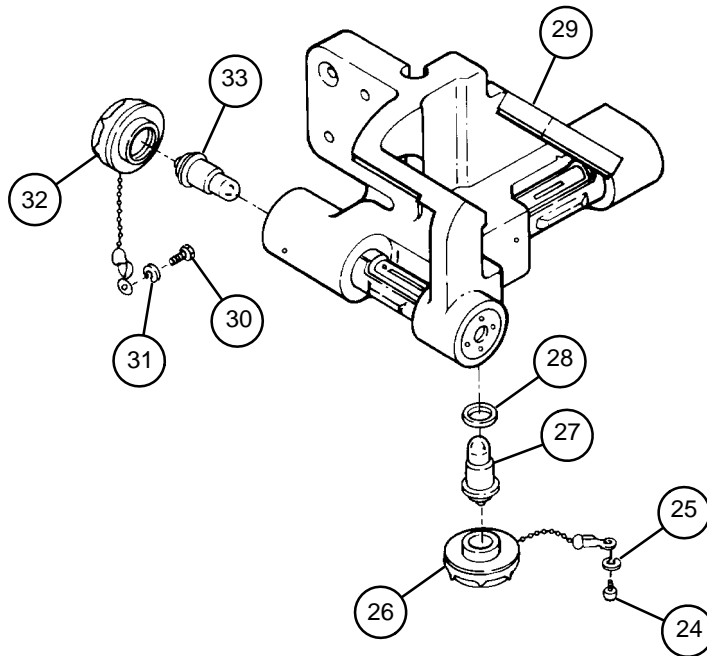
## 18-3 M145/M145A1 TELESCOPE MOUNT — CONTINUED

### f. Disassembly of Level Assembly

- 1 Remove machine screw (24), lockwasher (25), electrical cover (26), LED (27), and ring spacer (28) from level assembly (29). Discard lockwasher.
- 2 Remove ring spacer (28) from LED (27).
- 3 Remove machine screw (30), lockwasher (31), electrical cover (32), and LED (33). Discard lockwasher.

### g. Assembly of Level Assembly

- 1 Install LED (33) in level assembly (29).
- 2 Install electrical cover (32), new lockwasher (31), and machine screw (30).
- 3 Install ring spacer (28) on LED (27).
- 4 Install LED (27) with ring spacer (28), electrical cover (26), new lockwasher (25), and machine screw (24).





## h. Disassembly of Disk Assembly

### NOTE

Old disk assemblies contain lamps in place of LEDs, because LEDs do not provide adequate illumination to level of old disk assemblies.

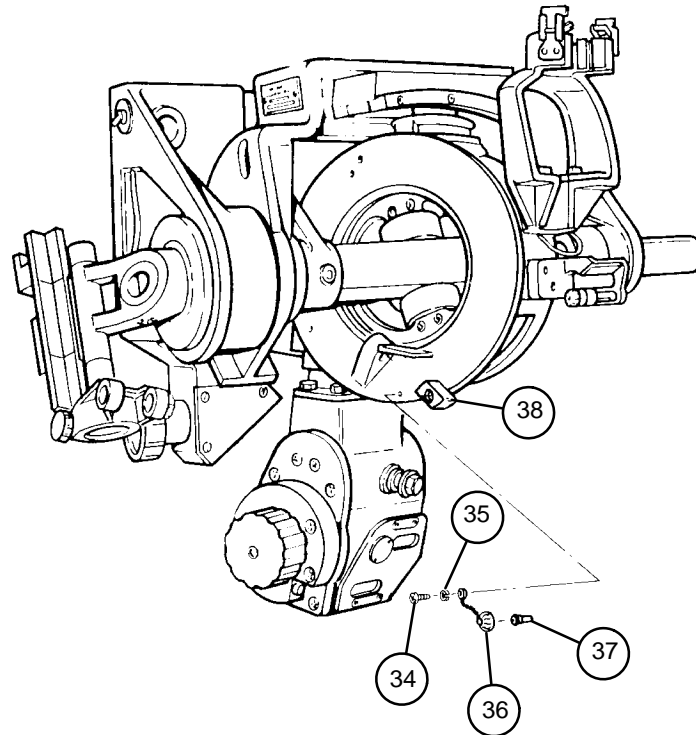
Remove machine screw (34), lockwasher (35), electrical cover (36), and LED (37) from disk assembly (38). Discard lockwasher.

## i. Assembly of Disk Assembly

### NOTE

Old disk assemblies contain lamps in place of LEDs and should NOT be replaced with LEDs.

- 1 Install LED (37) in disk assembly (38).
- 2 Install electrical cover (36), new lockwasher (35), and machine screw (34).



---

## 18-3 M145/M145A1 TELESCOPE MOUNT — CONTINUED

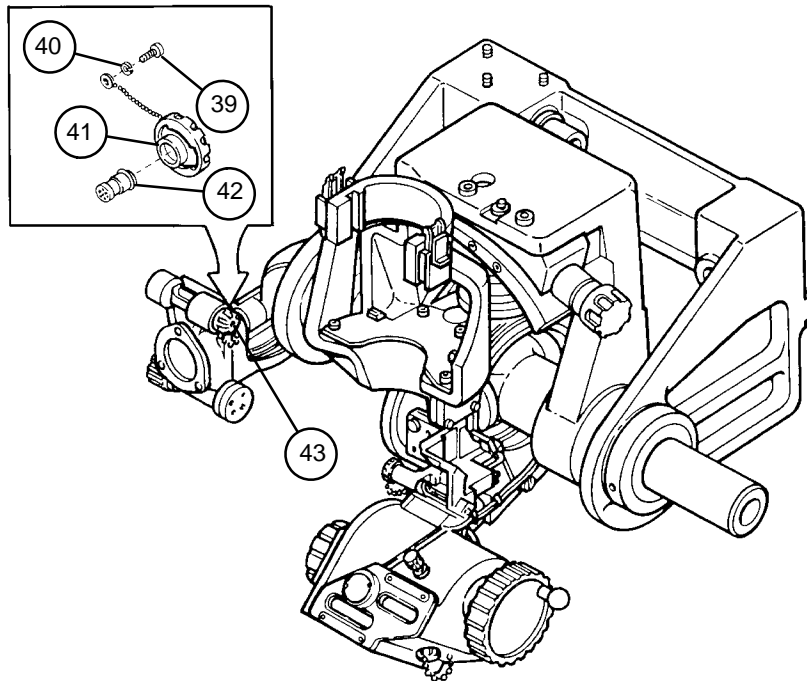
---

### j. Disassembly of Quadrant Support Assembly

Remove machine screw (39), lockwasher (40), electrical cover (41), and LED (42) from quadrant support assembly (43). Discard lockwasher.

### k. Assembly of Quadrant Support Assembly

- 1 Install LED (42) in quadrant support assembly (43).
- 2 Install electrical cover (41), new lockwasher (40), and machine screw (39).

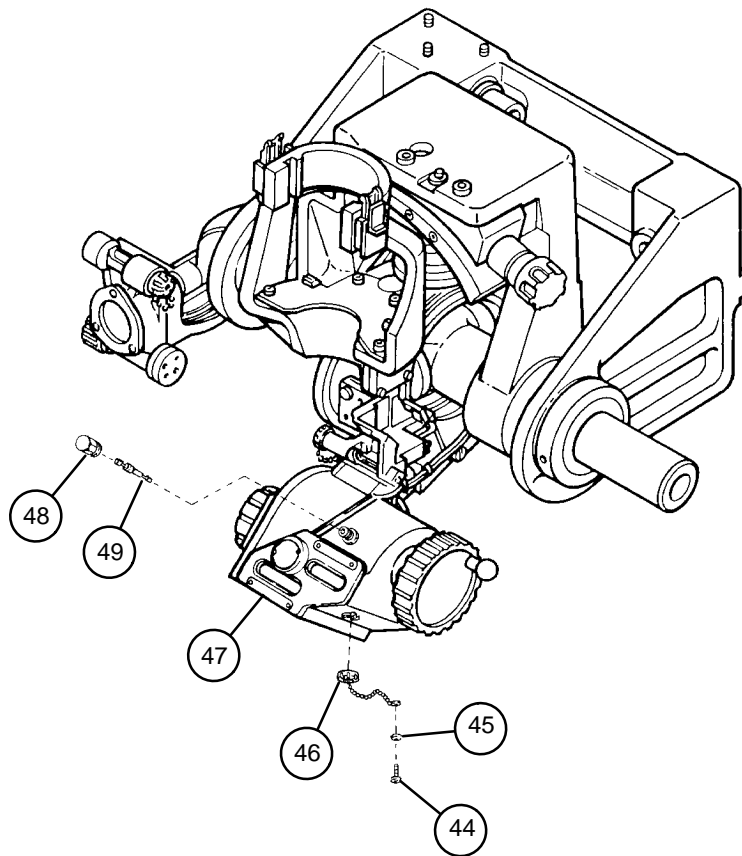


**I. Disassembly of Counter Box Assembly**

- 1 Remove machine screw (44), lockwasher (45), and electrical cover (46) from counter box assembly (47). Discard lockwasher.
- 2 Remove air valve cap (48) and valve core (49) from counter box assembly (47).

**m. Assembly of Counter Box Assembly**

- 1 Install electrical cover (46), new lockwasher (45), and machine screw (44) on counter box assembly (47).
- 2 Install valve core (49) and air valve cap (48).



## 18-3 M145/M145A1 TELESCOPE MOUNT — CONTINUED

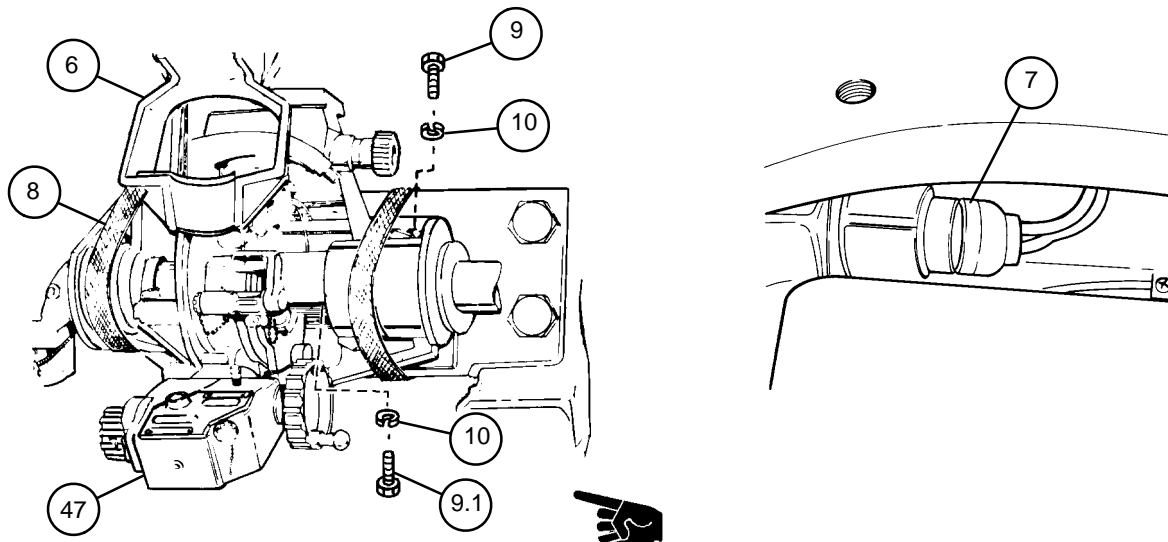
### n. Installation of M145/M145A1 Telescope Mount

- Two personnel raise M145/M145A1 telescope mount (6). One mechanic holds M145/M145A1 telescope mount in keyway of mounting plate (not shown). The second mechanic secures M145/M145A1 telescope mount to plate by attaching webbing strap (8) to M145/M145A1 telescope mount.

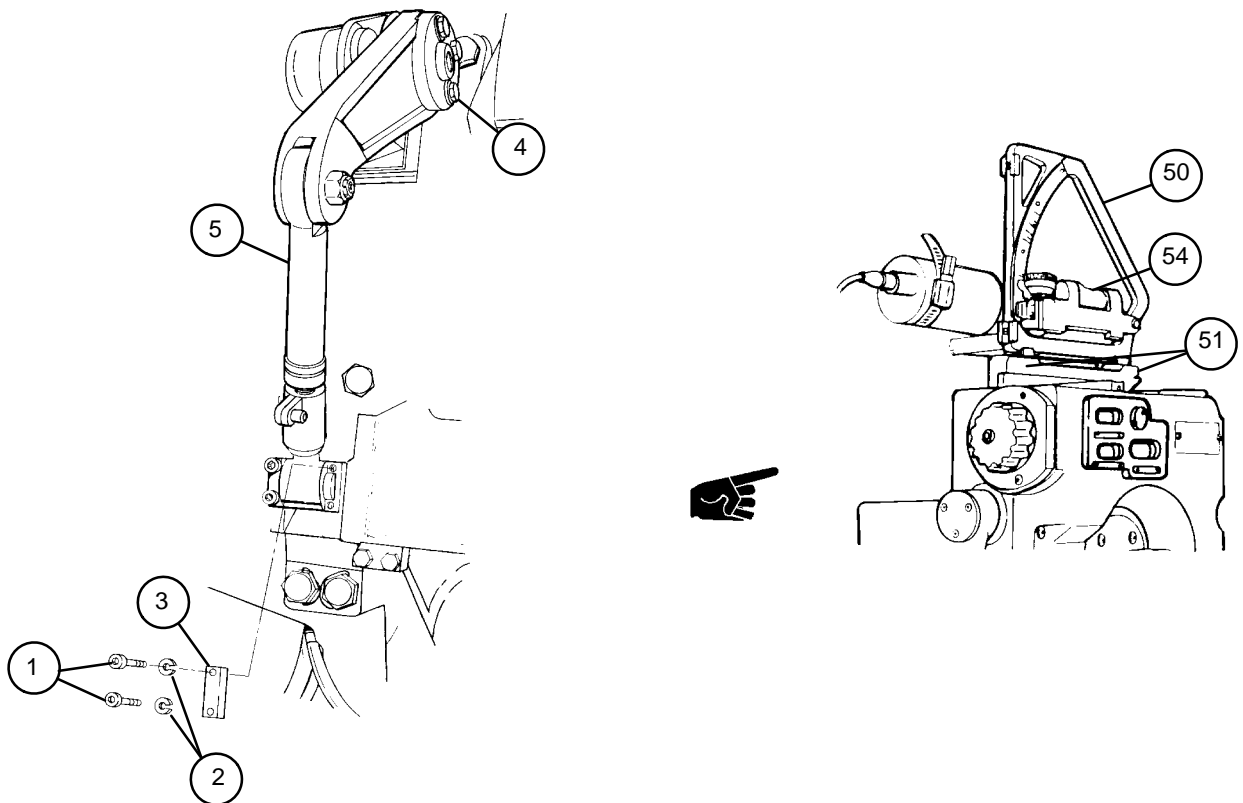
#### NOTE

- Two longer screws go in top holes.
- Tighten four cap screws to 80–90 lb-ft (108–122 N·m). After installation, M145/M145A1 telescope mount must be synchronized (para 18-4) .
- Leave a 1 inch (2.54 cm) gap between linkage assembly and M145/M145A1 telescope mount. If gap is less than 1 inch (2.54 cm), loosen four cap screws on linkage assembly plates. Move linkage assembly in or out until gap measures 1 inch (2.54 cm). Tighten four screws and re-check measurements.

- Install two cap screws (9), two cap screws (9.1), and four new lockwashers (10) on M145/M145A1 telescope mount (6) and remove webbing strap (8). Torque cap screws 80 to 90 ft-lb (108 to 122 N·m).
- Connect electrical connector (7).



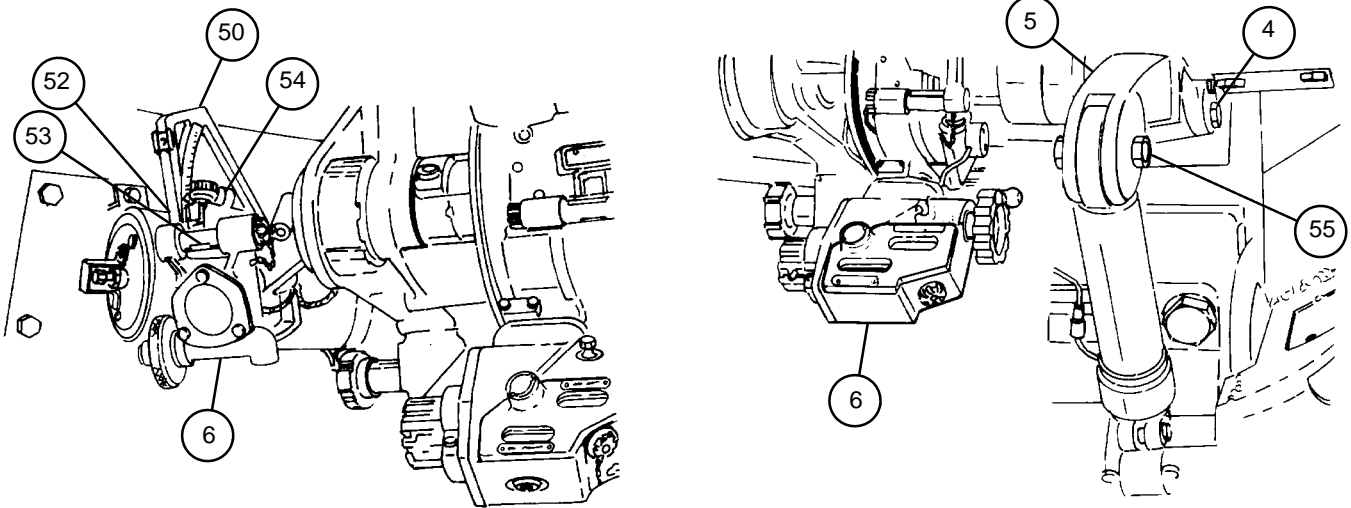
- 4 Install linkage assembly (5) using four cap screws (4).
- 5 Install two lower gun arm caps (3) in the exact position from which they were removed.
- 6 Install four cap screws (1) and four new lockwashers (2) on two lower gun arm caps (3).
- 7 Depress cannon tube to zero elevation, using M1A1 gunner's quadrant (50) (end-for-end correction applied) placed on M15 elevation quadrant seats (51).



## 18-3 M145/M145A1 TELESCOPE MOUNT — CONTINUED

### n. Installation of M145/M145A1 Telescope Mount – Continued

- 8 Place M1A1 gunner's quadrant (50) with zero reading (end-for-end-correction applied) on M145/M145A1 telescope mount (6) quadrant seats (52).
- 9 Center bubble on M145/M145A1 telescope mount (6) cross-level vial (53).
- 10 If bubble (54) in M1A1 gunner's quadrant (50) is centered, tighten four cap screws (4) on linkage assembly (5). If bubble is not centered, loosen four cap screws (4) on linkage assembly (5). Tap counter box assembly (47) to center bubble in M1A1 gunner's quadrant.
- 11 Tighten eccentric shaft (55) to 12 o'clock position.
- 12 Check synchronization of M145/M145A1 telescope mount (para 18-4c.).
- 13 Purge counter box assembly (47) (TM 750-116).



This page left intentionally blank.

---

## 18-4 M145/M145A1 TELESCOPE MOUNT: SYNCHRONIZATION AND ADJUSTMENT

---

- This task covers:
- a. Leveling Gun Trunnions
  - b. Checking Elevation Counter
  - c. Checking Synchronization of M145/M145A1 Telescope Mount
  - d. Adjusting Synchronization of M145/M145A1 Telescope Mount
- 

### **INITIAL SETUP**

#### Tools

Artillery and turret mechanic's tool kit  
(SC 5180-95-CL-A12)

Gun tube leveling fixture (item 2.1, Appx H)

#### References

TM 9-2350-311-10

DA Form 2408-4

#### Equipment Condition

Park vehicle on level ground (hard surface if available)

---

### **NOTE**

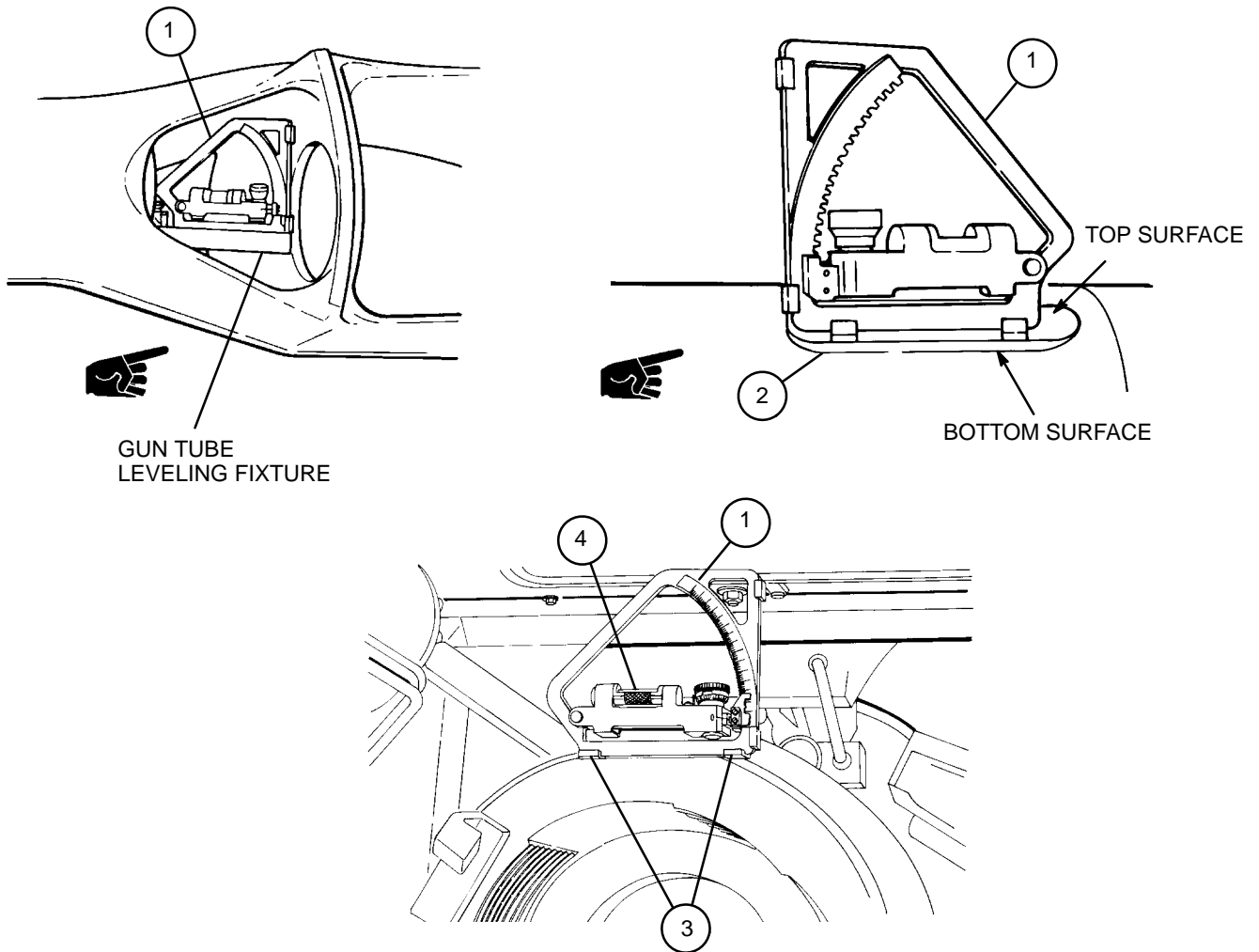
- The M145/M145A1 telescope mount must be synchronized whenever the M145/M145A1 telescope mount or linkage assembly is changed or whenever M145/M145A1 telescope mount may be out of synchronization.
- The following is not the most accurate method of leveling trunnions. It is acceptable for synchronizing M145/M145A1 telescope mount if an accurate M1A1 gunner's quadrant is used and if readings are taken with care. Instructions for more accurate plumbline method are given in TM 9-2350-311-10.
- Check synchronization of M145/M145A1 telescope mount (para 18-4c.). This checking procedure will pinpoint the assembly requiring adjustment or synchronization.
- Use an M1A1 gunner's quadrant that is accurate within 0.4 mil (tested by the end-for-end method). Whenever the M1A1 gunner's quadrant is used, the correction must be applied.
- Frequently check the cannon tube for drift during any synchronization procedure to reduce the chance of error due to cannon tube drift.
- Determine breech ring correction factor (TM 9-2350-311-10).



**a. Leveling Gun Trunnions**

**NOTE**

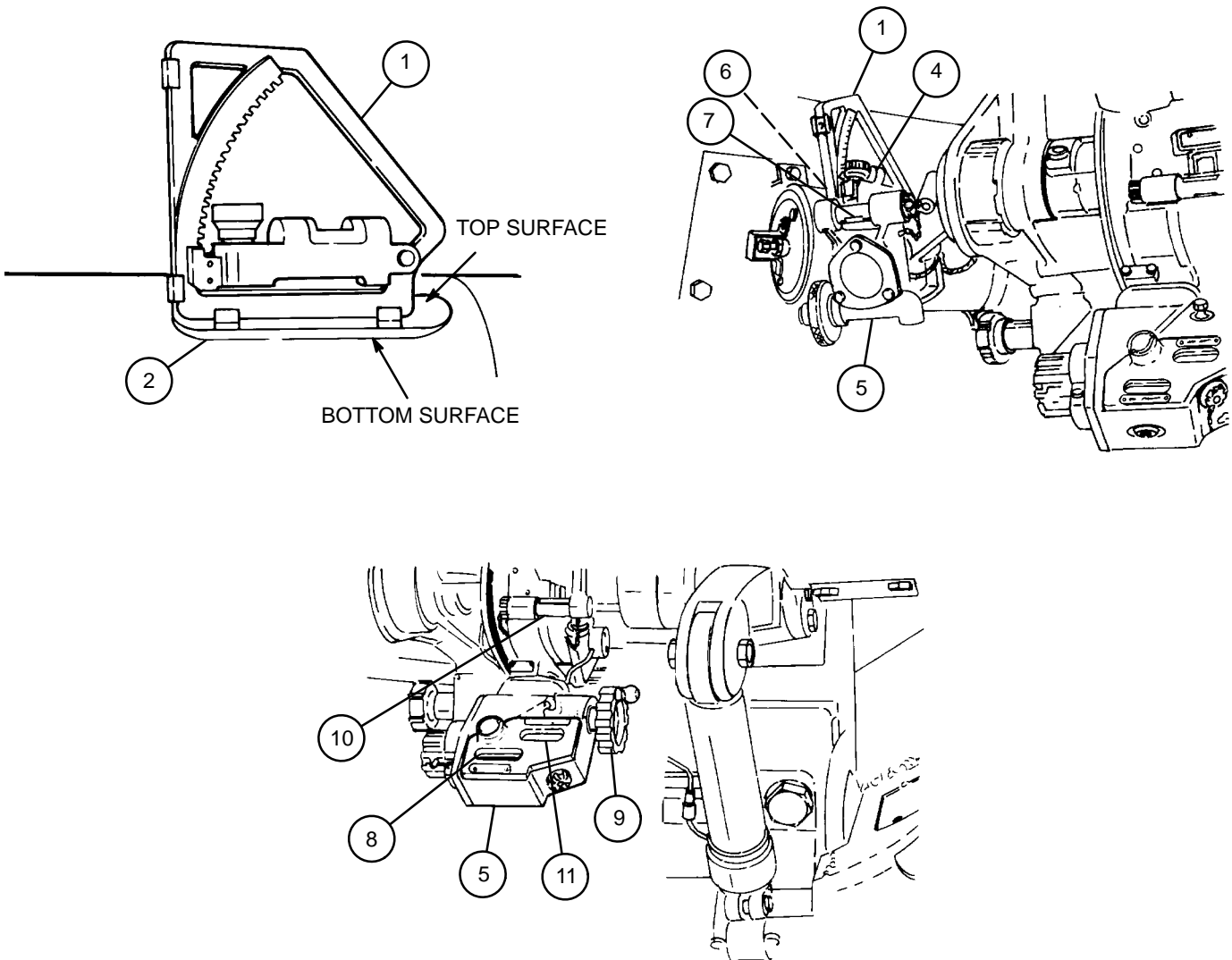
- All quadrant seats must be wiped clean before positioning gunner's quadrant on them for taking readings.
  - If cannon is not equipped with muzzle flats, use gun tube leveling fixture.
- 1 Bring cannon to zero elevation using M1A1 gunner's quadrant (1) (end-for-end correction applied) on the flat of the muzzle end of tube (2).
  - 2 Place M1A1 gunner's quadrant (1) with zero reading (end-for-end correction applied) on breech ring quadrant seats (3).
  - 3 Level gun trunnions by traversing cab left or right until bubble (4) is centered.



## 18-4 M145/M145A1 TELESCOPE MOUNT: SYNCHRONIZATION AND ADJUSTMENT — CONTINUED

### b. Checking Elevation Counter

- 1 Bring cannon tube to zero elevation, using M1A1 gunner's quadrant (1) (end-for-end correction applied) at muzzle end of tube (2).
- 2 Place M1A1 gunner's quadrant (1) with zero reading (end-for-end correction applied) on M145/M145A1 telescope mount (5) quadrant seats (6).
- 3 Center bubble on M145/M145A1 telescope mount (5) cross-level vial (7).
- 4 Set correction counter (8) to zero, then turn elevation handwheel (9) on M145/M145A1 telescope mount (5) until bubble in elevation level vial (10) is centered. Elevation counter (11) should read between 9999 and 0001. If elevation counter does not read between 9999 and 0001, notify support maintenance.



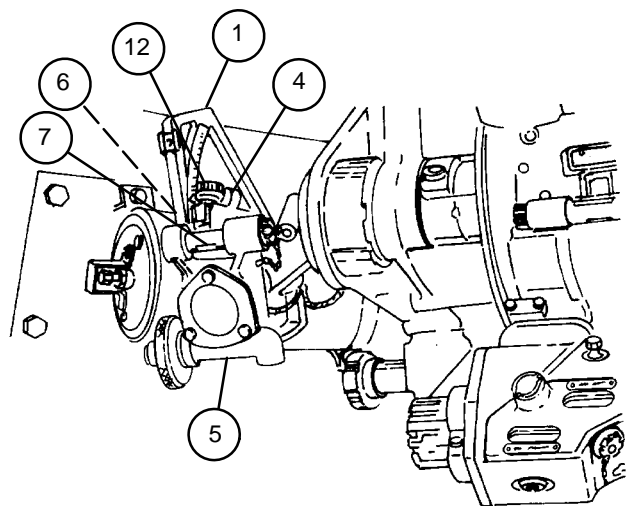
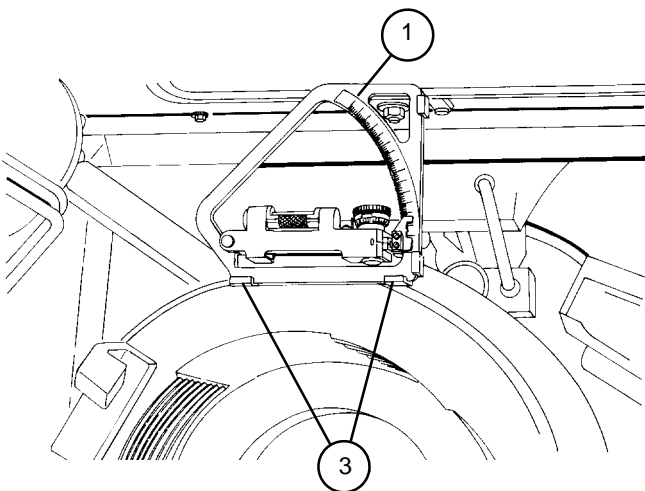
### c. Checking Synchronization of the M145/M145A1 Telescope Mount

- 1 Elevate cannon tube to 400 mils using M1A1 gunner's quadrant (1) (end-for-end correction applied) (breach ring correction applied) placed on breach ring quadrant seats (3).

#### NOTE

With M1A1 gunner's quadrant on M145/M145A1 telescope mount quadrant seats, the bubble in the M1A1 gunner's quadrant can be read more accurately by observing M1A1 gunner's quadrant bubble with inspection mirror.

- 2 Place M1A1 gunner's quadrant (1) with reading of 400 mils (end-for-end correction applied) (breach ring correction removed) on M145/M145A1 telescope mount (5) quadrant seats (6).
- 3 Center bubble in M145/M145A1 telescope mount (5) cross-level vial (7).
- 4 Bubble (4) on M1A1 gunner's quadrant (1) should also be centered. If bubble on M1A1 gunner's quadrant is not centered, turn micrometer knob (12) until bubble on M1A1 gunner's quadrant is centered.
- 5 Record reading of M1A1 gunner's quadrant (1).
- 6 Repeat steps 1 through 5 for elevations at 800 and 1200 mils.
- 7 Compare elevation readings taken at 400 mils, 800 mils, and 1200 mils.
  - (a) If the error at each of the three elevations does not exceed  $\pm 0.5$  mils, no adjustment is necessary.
  - (b) If the error at any elevation exceeds  $\pm 0.5$  mils adjustment is necessary. Adjust the M145/M145A1 telescope mount (5) (para 18-4d.).



## 18-4 M145/M145A1 TELESCOPE MOUNT: SYNCHRONIZATION AND ADJUSTMENT — CONTINUED

### d. Adjusting Synchronization of the M145/M145A1 Telescope Mount

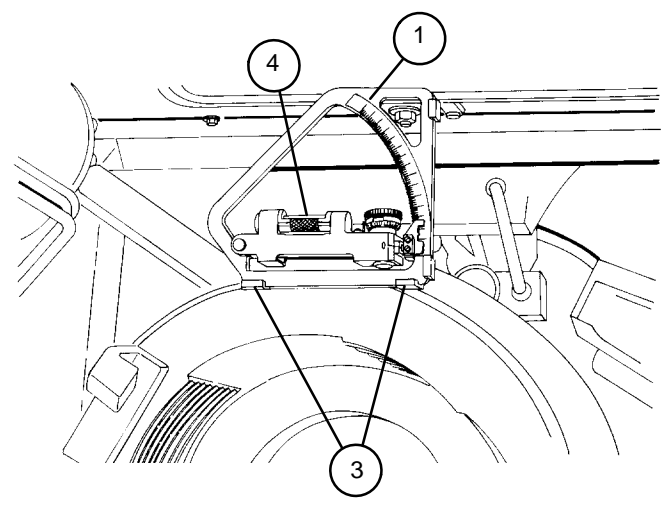
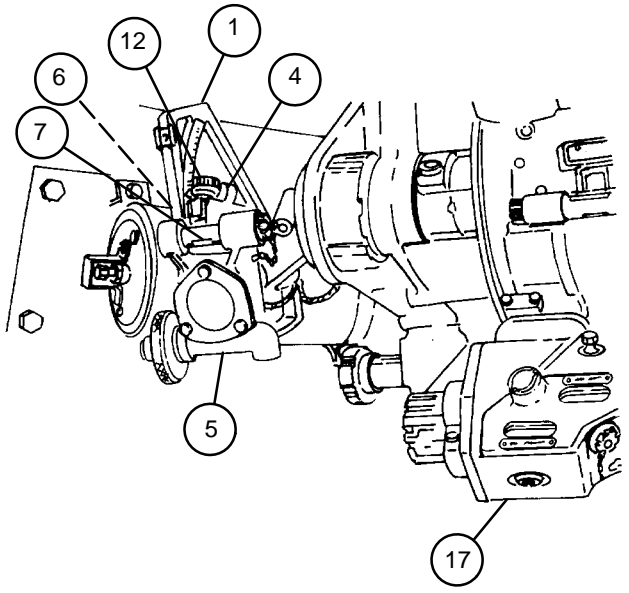
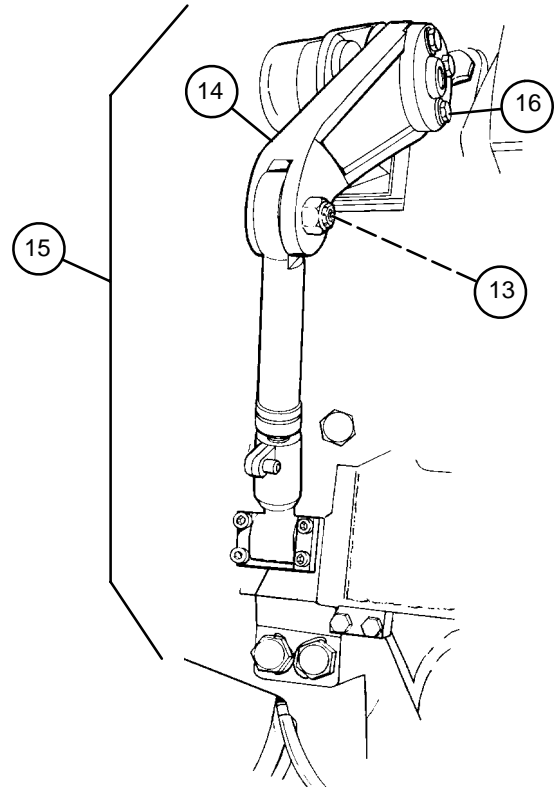
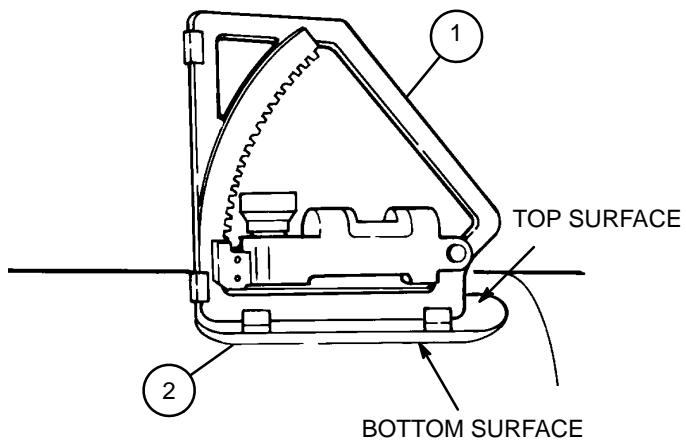
#### NOTE

- All movement of the cannon should be in elevation with no over travel.
- All level vials should be brought to level from left to right with no over travel.
- If muzzle is not equipped with flats, use gun tube leveling fixture.

- 1 Level the gun tube to zero at muzzle end of tube (2) by using M1A1 gunner's quadrant (1) (end-for-end correction applied).
- 2 Rotate the eccentric shaft (13) until the eccentric mark is in the 12 o'clock position.
- 3 Ensure 1 inch (25.4 mm) space between arm (14) of linkage assembly (15) and M145/M145A1 telescope mount (5). Loosen four cap screws (16) and adjust as necessary.
- 4 Set the M1A1 gunner's quadrant (1) to zero mils (end-for-end correction applied), (breech ring correction factor removed) and place on M145/M145A1 telescope mount (5) quadrant seats (6). Ensure cross-level vial bubble (7) is centered. Zero the M145/M145A1 telescope mount by loosening screws (16) and tap the elevation counter box (17) up or down until bubble (4) is centered. Retighten screws. Recheck bubble.
- 5 Set M1A1 gunner's quadrant (1) (end-for-end correction applied) (breech ring correction factor applied) to 400 mils and place on the breech ring quadrant seats (3). Elevate gun until bubble (4) is centered in the M1A1 gunner's quadrant.
- 6 Remove the M1A1 gunner's quadrant (1) (end-for-end correction applied) (breech ring correction factor removed) from the breech, set M1A1 gunner's quadrant to 400 mils, place M1A1 gunner's quadrant on the M145/M145A1 telescope mount (5) quadrant seats (6) and ensure cross-level vial bubble (7) is centered.
- 7 If the bubble (4) on the M1A1 gunner's quadrant (1) is not centered, turn micrometer knob (12) until the bubble is centered. Remove M1A1 gunner's quadrant, observe the offset reading. If the bubble is within  $\pm 0.5$  mils proceed to step 12. If bubble is not within the tolerance proceed to step 8.
- 8 If the offset is greater than 400 mils, add twice the offset to 400 mils. If offset is less than 400 mils, subtract twice the offset from 400 mils. Set the results on the M1A1 gunner's quadrant (1) (end-for-end correction applied) and place the M1A1 gunner's quadrant back on the M145/M145A1 telescope mount (5) quadrant seats (6).

Example:

Offset reading	Offset	Results	Set results
400.8	.8 x 2	1.6	400 + 1.6 = 401.6
399.2	.8 x 2	1.6	400 - 1.6 = 398.4



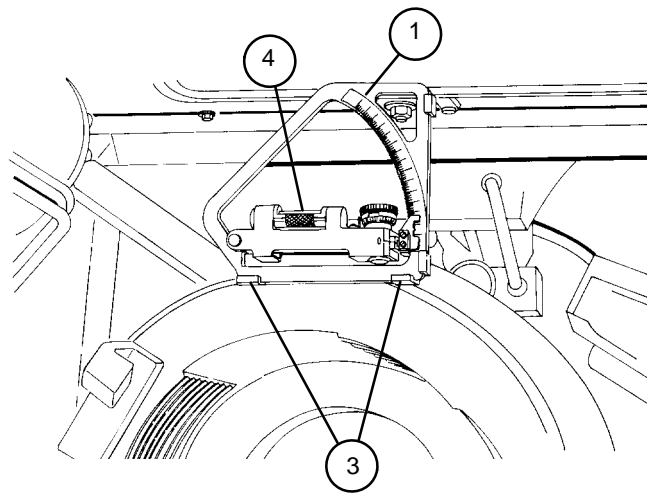
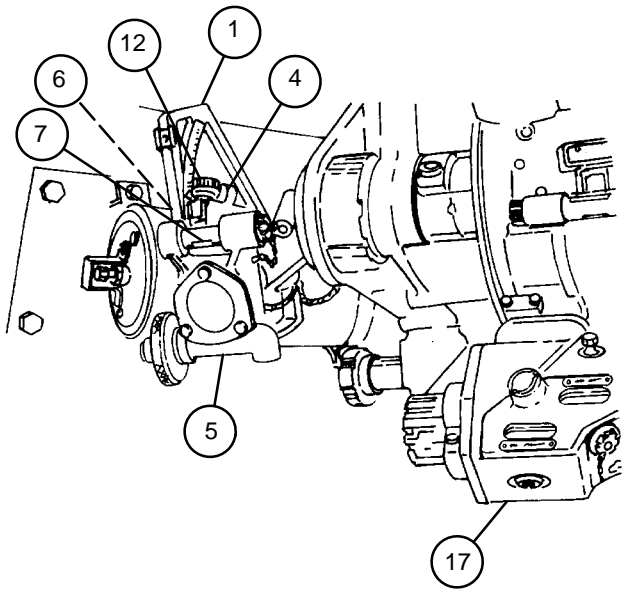
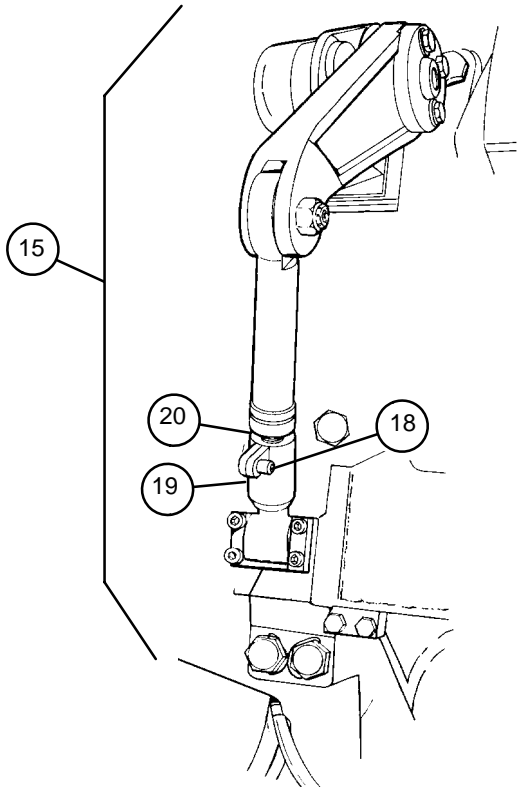
---

## 18-4 M145/M145A1 TELESCOPE MOUNT: SYNCHRONIZATION AND ADJUSTMENT — CONTINUED

---

### d. Adjusting Synchronization of the M145/M145A1 Telescope Mount – Continued

- 9 Loosen cap screw (18) on the link connector (19) of the linkage assembly (15). Rotate the adjustment rod (20) until bubble (4) is centered.
- 10 Remove M1A1 gunner's quadrant (1) from M145/M145A1 telescope mount (5) quadrant seats (6). Set M1A1 gunner's quadrant (end-for-end correction applied) (breech ring correction factor applied) to zero and place on breech ring seats (3). Level gun tube.
- 11 Remove M1A1 gunner's quadrant (1) from breech ring seats (3). Place M1A1 gunner's quadrant (end-for-end correction applied) (breech ring correction factor removed) on M145/M145A1 telescope mount (5) quadrant seats (6). Ensure cross-level vial (7) is centered and verify bubble (4) is centered. If not centered repeat steps 4 through 11 until zero is achieved.
- 12 Once the M145/M145A1 telescope mount (5) is within tolerance at 400 mils, set 800 mils on M1A1 gunner's quadrant (1) (end-for-end correction applied) (breech ring correction factor applied) and place on breech ring seats (3). Elevate gun tube until bubble (4) is centered in M1A1 gunner's quadrant.
- 13 Remove M1A1 gunner's quadrant (1) from breech ring seats (3). Place M1A1 gunner's quadrant (end-for-end correction applied) (breech ring correction factor removed) on M145/M145A1 telescope mount (5) quadrant seats (6). Verify that M145/M145A1 telescope mount is within  $800 \pm 0.5$  mils.
- 14 Remove M1A1 gunner's quadrant (1) from M145/M145A1 telescope mount (5) quadrant seats (6). Set M1A1 gunner's quadrant (end-for-end correction applied) (breech ring correction factor applied) to 1200 mils and place on breech ring seats (3). Elevate gun tube until bubble (4) is centered in M1A1 gunner's quadrant.
- 15 Remove M1A1 gunner's quadrant (1) from breech ring seats (3). Place M1A1 gunner's quadrant (end-for-end correction applied) (breech ring correction factor removed) on M145/M145A1 telescope mount (5) quadrant seats (6). Verify that M145/M145A1 telescope mount is within  $1200 \pm 0.5$  mils.
- 16 If steps 13 or 15 fail, repeat entire procedure once. If problem is not corrected inspect linkage assembly (15). Repeat entire procedure, if problem still persist replace M145/M145A1 telescope mount (5).



All data on pages 18-26 through 18-29, including illustrations have been deleted.





This page left intentionally blank.

---

## 18–5 M117/M117A2 PANORAMIC TELESCOPE

---

This task covers:

a. Inspection	b. Disassembly
c. Assembly	

---

### **INITIAL SETUP**

#### Tools

Artillery and turret mechanic's tool kit  
(SC 5180–95–CL–A12)

#### Materials/Parts

■ Lockwasher (item 69, Appx G)

Lockwashers (2) (item 58, Appx G)  
Sealing compound (item 28, Appx D)

#### References

TM 9–2350–311–10  
TM 750–116

---

### a. Inspection

For inspection refer to TM 9–2350–311–10.

### b. Disassembly

#### **NOTE**

For removal and installation instructions, refer to TM 9–2350–311–10. For purging and charging instructions, refer to TM 750–116.

- 1 Remove two air valve caps (1), two valve cores (2), two purging valve stems (3) and two straps (4).
- 2 Remove optical eyeshield (5).
- 3 Remove two machine screws (6), two lockwashers (7), two electrical covers (8) and two LEDs (9). Discard lockwashers.
- 4 Remove machine screw (10).
- 5 Remove machine screw (11), lockwasher (12), and cap assembly (13). Discard lockwasher.

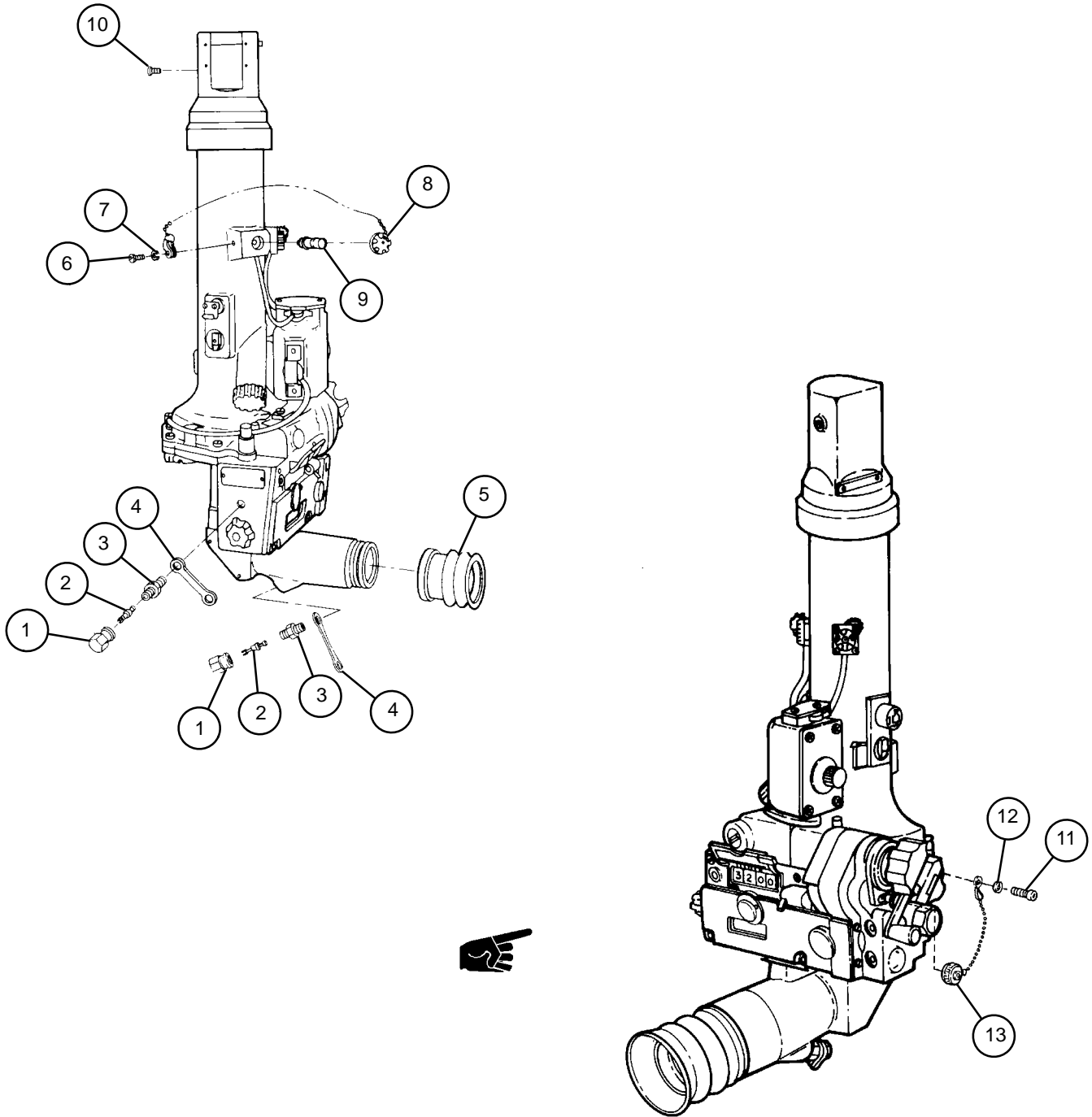
### c. Assembly

- 1 Install chain of cap assembly (13) under machine screw (11) and new lockwasher (12). Install cap assembly.
- 2 Install machine screw (10).
- 3 Install two LEDs (9), two electrical covers (8), two new lockwashers (7), and two machine screws (6).
- 4 Install optical eyeshield (5).
- 5 Apply sealing compound to two purging valve stems (3).
- 6 Install two straps (4), two purging valve stems (3), two valve cores (2), and two air valve caps (1).

**NOTE**

Nitrogen charge was released when valve cores and machine screw were removed.

7 Purge and charge (TM 750-116).



## 18-6 M15 ELEVATION QUADRANT

- This task covers:
- |                 |             |
|-----------------|-------------|
| a. Inspection   | b. Removal  |
| c. Disassembly  | d. Assembly |
| e. Installation |             |

### INITIAL SETUP

Tools

Artillery and turret mechanic's tool kit  
(SC 5180-95-CL-A12)

References

TM 9-2350-311-10  
TM 750-116

Materials/Parts

Lockwasher (item 58, Appx G)  
Lockwashers (4) (item 83, Appx G)  
Sealing compound (item 28, Appx D)

Equipment Condition

M118A2/M118A3 elbow telescope removed  
(TM 9-2350-311-10)

#### a. Inspection

For inspection refer to TM 9-2350-311-10.

#### b. Removal

- 1 Disconnect electrical connector (1).

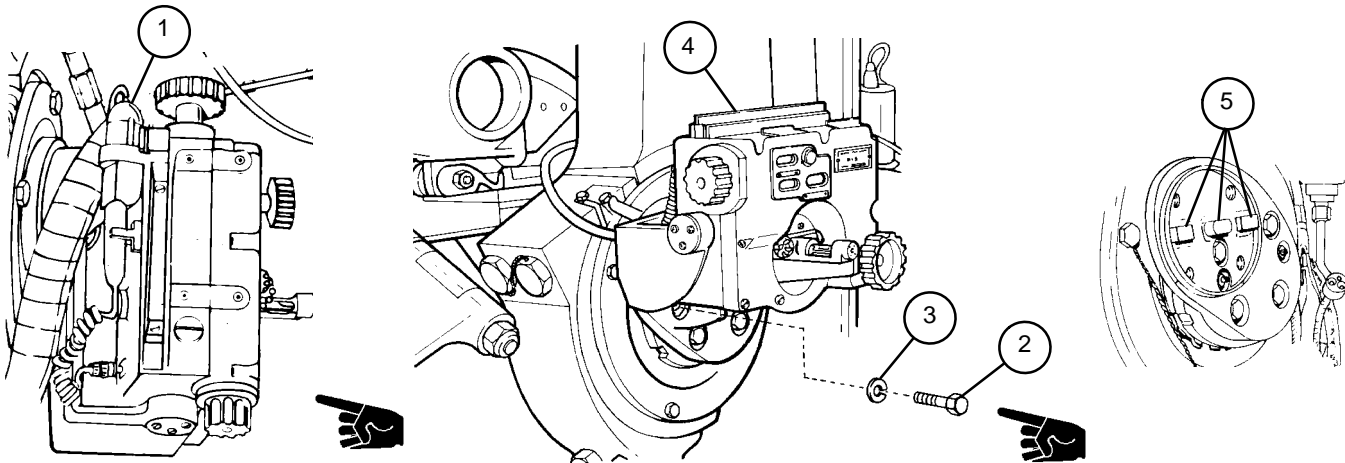
**WARNING**

M15 elevation quadrant weighs 37 pounds (16.8 kg). Support M15 elevation quadrant to prevent bodily injury or damage to equipment.

**NOTE**

For ease of removal, cant M15 quadrant by rotating knob to gain access to cap screws.

- 2 Remove four cap screws (2) and four lockwashers (3). Discard lockwashers.
- 3 Pull M15 quadrant (4) straight off to clear locating keys (5).



**c. Disassembly**

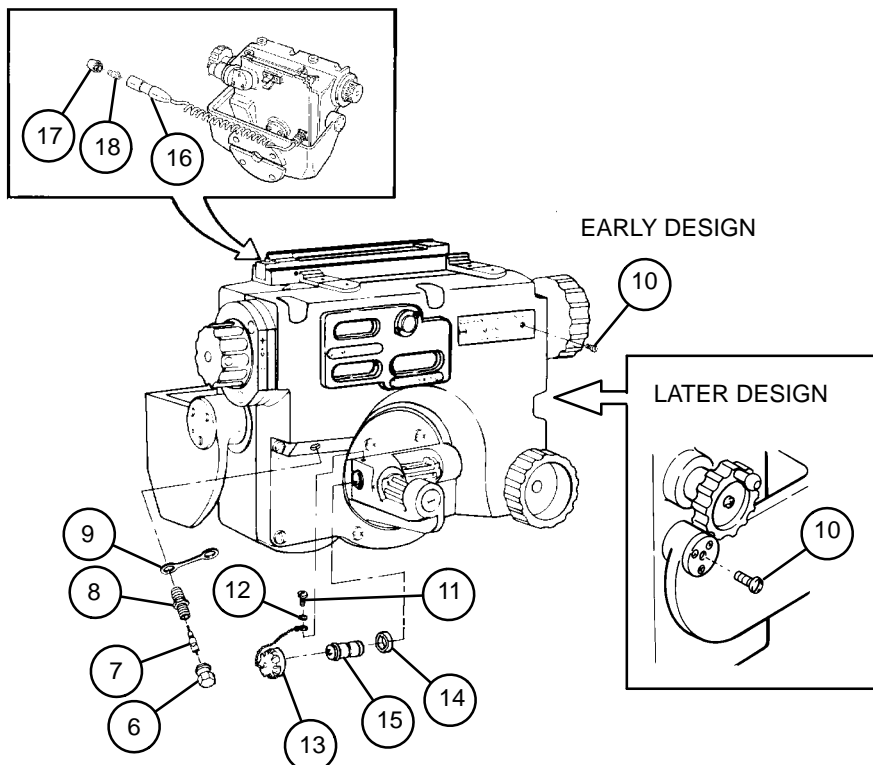
**NOTE**

Refer to either the early design or later design illustrations when performing these procedures.

- 1 Remove air valve cap (6), valve core (7), purging valve stem (8) and strap (9).
- 2 Remove exit port machine screw (10).
- 3 Remove machine screw (11), lockwasher (12), electrical cover (13), spacer (14), and LED (15). Discard lockwasher.
- 4 Disconnect extension light assembly (16) from rear of M15 quadrant (4).
- 5 Remove lens (17) and LED (18) from extension light assembly (16).

**d. Assembly**

- 1 Install LED (18) and lens (17) in extension light assembly (16).
- 2 Connect extension light assembly (16) to rear of M15 quadrant (4).
- 3 Install spacer (14) onto LED (15).
- 4 Install LED (15) with spacer (14), electrical cover (13), new lockwasher (12), and machine screw (11).
- 5 Install exit port machine screw (10).
- 6 Apply sealing compound to purging valve stem (8) threads.
- 7 Install strap (9), purging valve stem (8), valve core (7), and air valve cap (6).



---

## 18-6 M15 ELEVATION QUADRANT — CONTINUED

---

### d. Assembly — CONTINUED

#### NOTE

Nitrogen charge was released when valve core and exit port machine screw were removed.

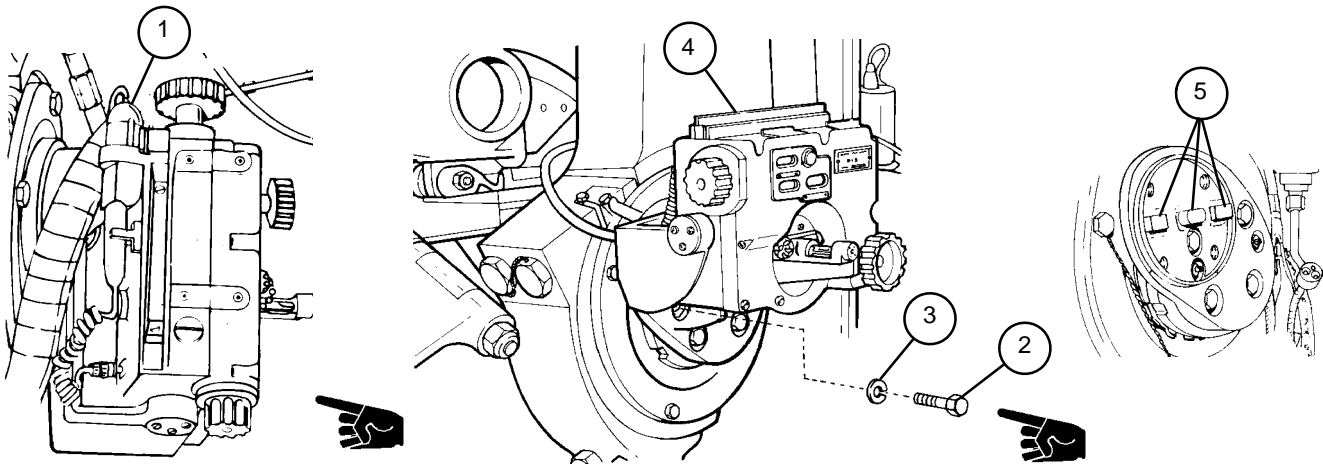
- 8 Purge (TM 750-116).

### e. Installation

#### NOTE

For ease of installation, cant M15 quadrant by rotating knob to gain access to mounting holes.

- 1 Aline M15 quadrant (4) with locating keys (5) and push into position.
- 2 Install four new lockwashers (3) and four cap screws (2).
- 3 Connect electrical connector (1).





## 18-7 M42 TANK PERISCOPE — CONTINUED

---

### b. Disassembly

#### NOTE

There are currently two production models of the M42 tank periscope in use. Early models do not use removable charging port parts.

- 1 Remove two straight pins (3).
- 2 Remove air valve cap (5), valve core (6), purging valve stem (7) and strap (8).
- 3 Remove three machine screws (9), three lockwashers (10), retaining ring (11), and seal (12). Discard lockwashers.

### c. Assembly

- 1 Install seal (12), retaining ring (11), three new lockwashers (10), and three machine screws (9).
- 2 Apply sealing compound to purging valve stem (7) threads.
- 3 Install strap (8), purging valve stem (7), valve core (6) and air valve cap (5).
- 4 Install two straight pins (3).

#### NOTE

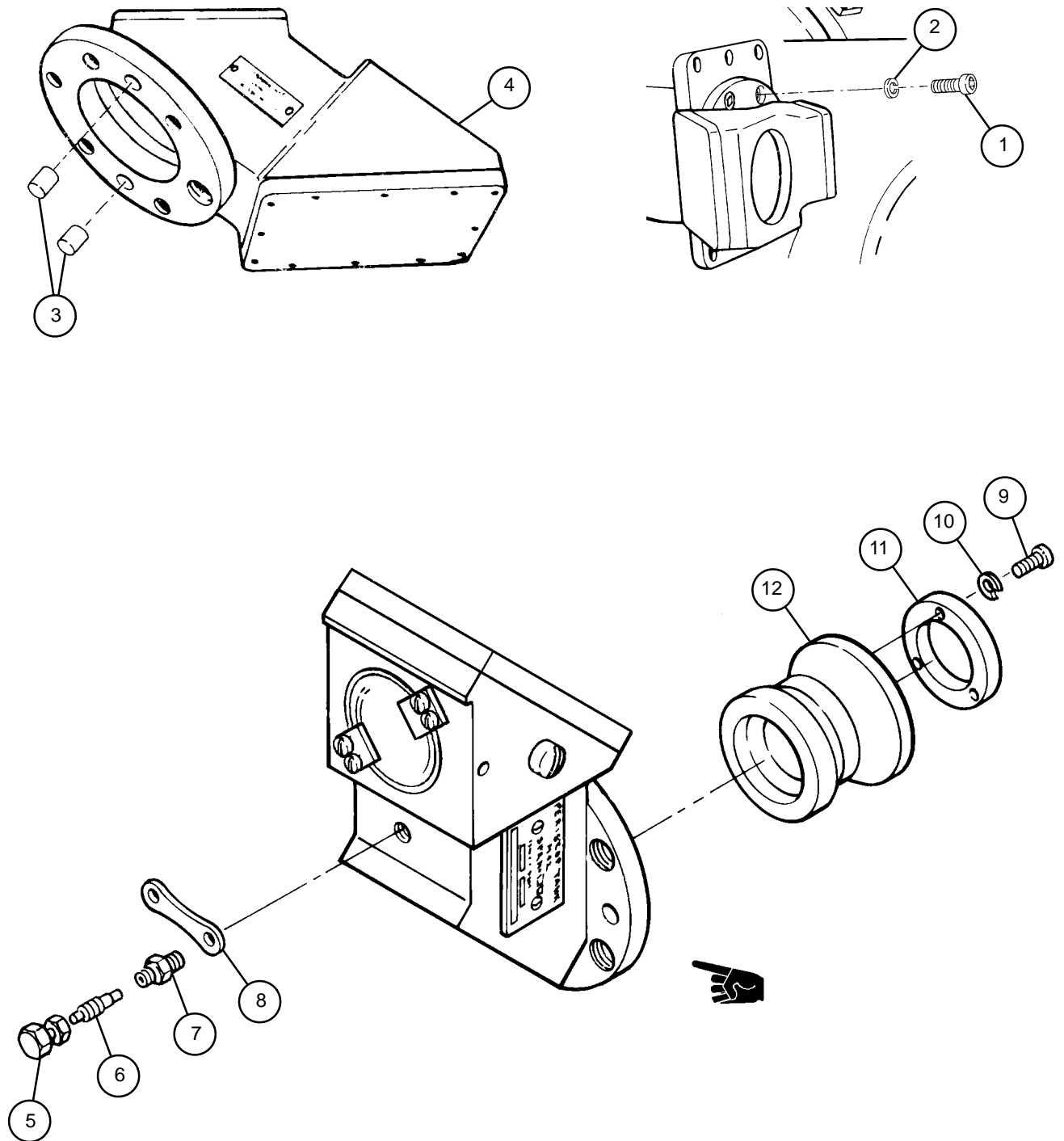
Nitrogen charge was released when valve core and machine screw were removed.

- 5 Purge and charge (TM 750-116).

### d. Installation

- 1 Install M42 tank periscope (4) by inserting straight pins (3) in holes.
- 2 Install five new lockwashers (2) and five cap screws (1).







## CHAPTER 19 PURGING AND CHARGING

---

### GENERAL

This chapter provides procedures for purging, charging, and servicing with high pressure nitrogen, the components in the cab.

---

<u>CONTENTS</u>	<u>Page</u>
19-1 REPLENISHER ACCUMULATOR ASSEMBLY .....	19-2
19-2 RECUPERATOR ASSEMBLY .....	19-4
19-3 ACCUMULATOR ASSEMBLY, MANUAL PUMP .....	19-12
19-4 ACCUMULATOR ASSEMBLY, MAIN .....	19-18
19-5 ACCUMULATOR ASSEMBLY, PRIMARY .....	19-22
19-6 ACCUMULATOR ASSEMBLY, SECONDARY .....	19-28

---

## 19-1 REPLENISHER ACCUMULATOR ASSEMBLY

---

This task covers: Servicing with High Pressure Nitrogen

---

### INITIAL SETUP

#### Tools

Nitrogen charging kit (item 3, App. H)  
Purging kit, fire control (item 4, Appx H)

#### Materials/Parts

Dry nitrogen (item 22, Appx D)  
Soap (item 33, Appx D)

---

### Servicing with High Pressure Nitrogen

**WARNING**

Make sure charging cylinder contains dry nitrogen. Dry nitrogen tanks are marked with one or two black bands. Certain other gases can cause accumulator to explode, resulting in possible injury and equipment damage.

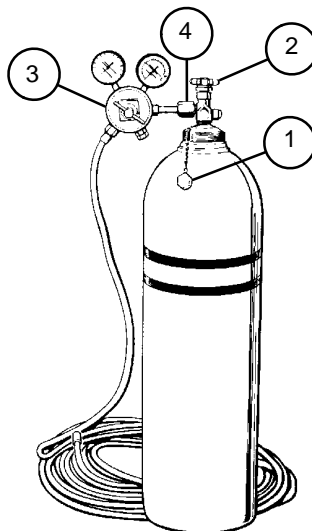
**CAUTION**

Under no circumstances exceed the pressures indicated in the following procedures to prevent damage to equipment.

#### NOTE

Fire control charging kit is used to charge accumulator replenisher assembly to obtain low pressure required.

- 1 To set up fire control charging equipment, remove protective cover (1) from shutoff valve (2).
- 2 Open shutoff valve (2) momentarily to rid valve seat of any foreign matter.
- 3 Attach regulator (3) securely using adapter (4).



**NOTE**

- Two regulator assemblies are currently used for purging and charging fire control materiel. The insert shows regulator 5580922, while the tank is shown with regulator 11729749.
- With regulator 11729749, an adapter must be used to connect hose assembly to low pressure port of regulator. Use a right or left-hand threaded 9/16 X 18 NF adapter, depending on thread requirements of the hose assembly coupling.

- 4 Attach hose assembly (5) to low pressure port (6).
- 5 Shut off pressure regulator valve (7) by rotating counterclockwise.

**NOTE**

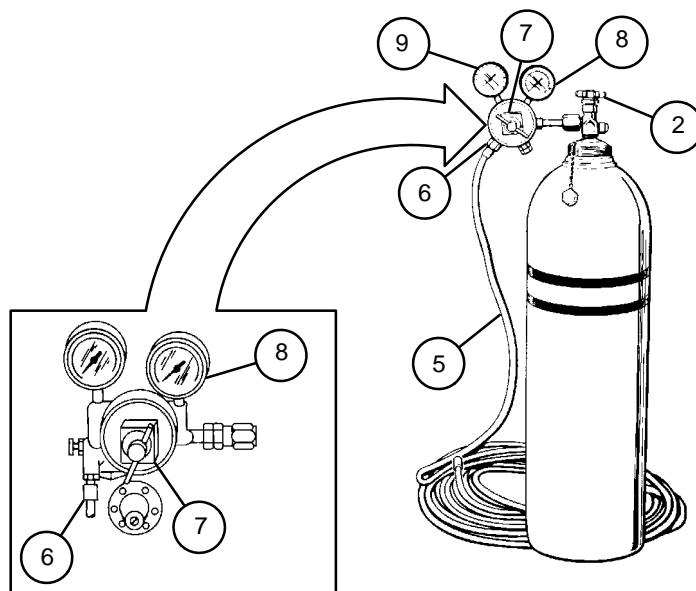
If pressure indicated is less than 100 psi (690 kPa), replace tank.

- 6 Open shutoff valve (2) slowly. Adjust until maximum tank pressure registers on high pressure gage (8).

**NOTE**

Gages labeled 0-15 psi, 0-30 psi, or 0-60 psi are authorized but must be in 1 psi increments.

- 7 Rotate pressure regulator valve (7) slowly clockwise until approximately 5 psi (34 kPa) registers on low pressure gage (9).



## 19-1 REPLENISHER ACCUMULATOR ASSEMBLY

---

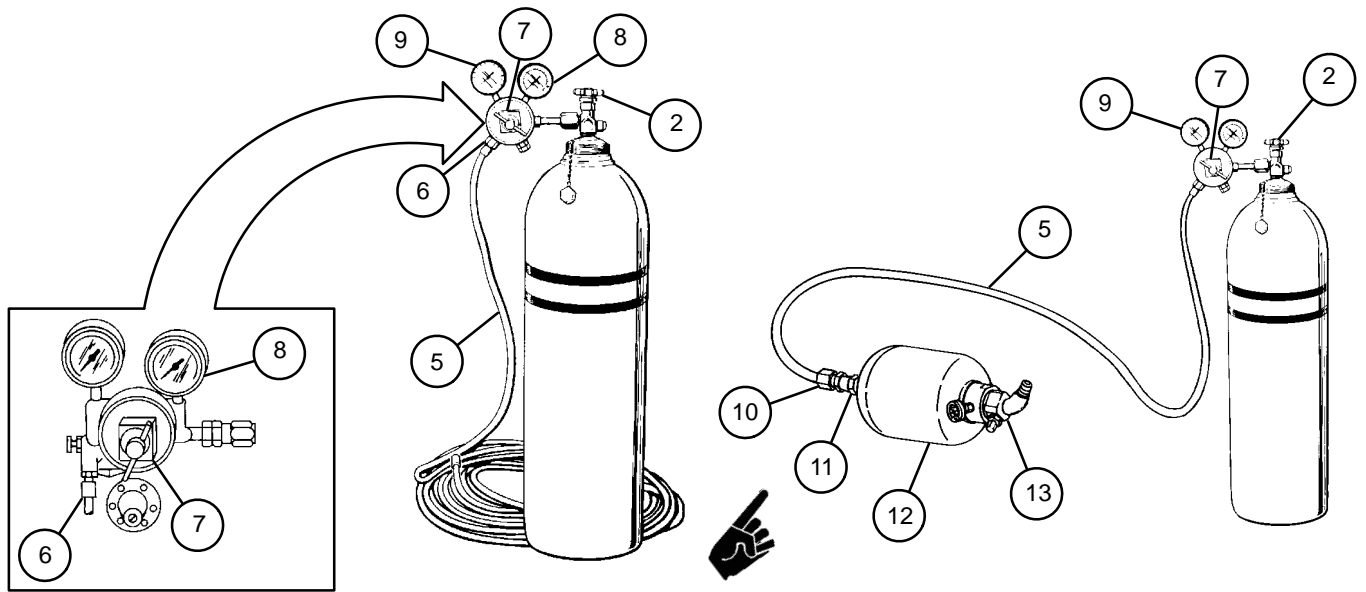
### Servicing with High Pressure Nitrogen – Continued

- 8 Check for blockage and eliminate if necessary.
- 9 Close shutoff valve (2). Allow nitrogen to bleed from regulator (3) and hose assembly (5).
- 10 Close pressure regulator valve (7). Turn counterclockwise.
- 11 Remove nut (10) from gas valve (11).
- 12 To charge accumulator replenisher (12), connect hose assembly (5) to gas valve (11), but do not tighten at this time.
- 13 Open shutoff valve (2) and pressure regulator valve (7) slowly to purge hose assembly (5).
- 14 Close pressure regulator valve (7) and tighten connection on filling valve (13) by rotating slowly clockwise.

#### NOTE

Gages labeled 0-15 psi, 0-30 psi, or 0-60 psi are authorized but must be in 1 psi increments.

- 15 Rotate regulator valve (7) until 7 to 8 psi (48-55 kPa) registers on low pressure gage (9).
- 16 Close pressure regulator valve (7) and disconnect hose assembly (5) at gas valve (11). Install nut (10) onto gas valve (11). Apply soap suds to filling valve (13) to check for leaks.



## 19-2 RECUPERATOR ASSEMBLY

- This task covers:
- a. Servicing with Hydraulic Fluid
  - b. Servicing with High Pressure Nitrogen – Method One
  - c. Servicing with High Pressure Nitrogen – Method Two

### INITIAL SETUP

Tools

Nitrogen charging kit (item 3, Appx H)  
M3 pump kit (item 9, Appx H)  
Purging kit (item 4, Appx H)

Materials/Parts

Hydraulic fluid OHT (item 21, Appx D)  
Dry nitrogen (item 22, Appx D)  
Soap (item 33, Appx D)

#### a. Servicing with Hydraulic Fluid

- 1 Remove valve cap (1) from check valve (2) at head end of recuperator cylinder (3) inside cab.

**CAUTION**

Hydraulic fluid must be new. Recuperator assembly must be free of contaminating matter.

**NOTE**

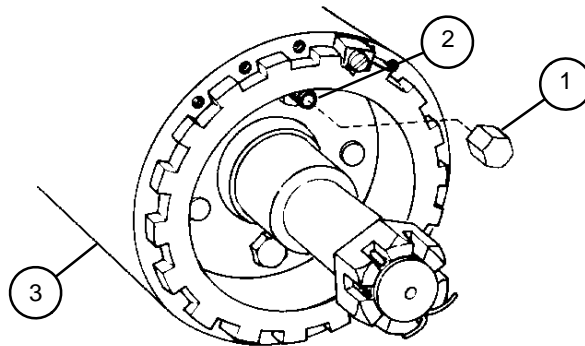
Rotate head to position drain plug at bottom.

- 2 Attach M3 oil pump (4) to check valve (2). Fill head until two pins (5) extend not less than 1/8 inch (3.2 mm). Do not overfill (head requires about 0.7 pint (0.3 l)). After filling, disconnect M3 oil pump.
- 3 Install valve cap (1).

**CAUTION**

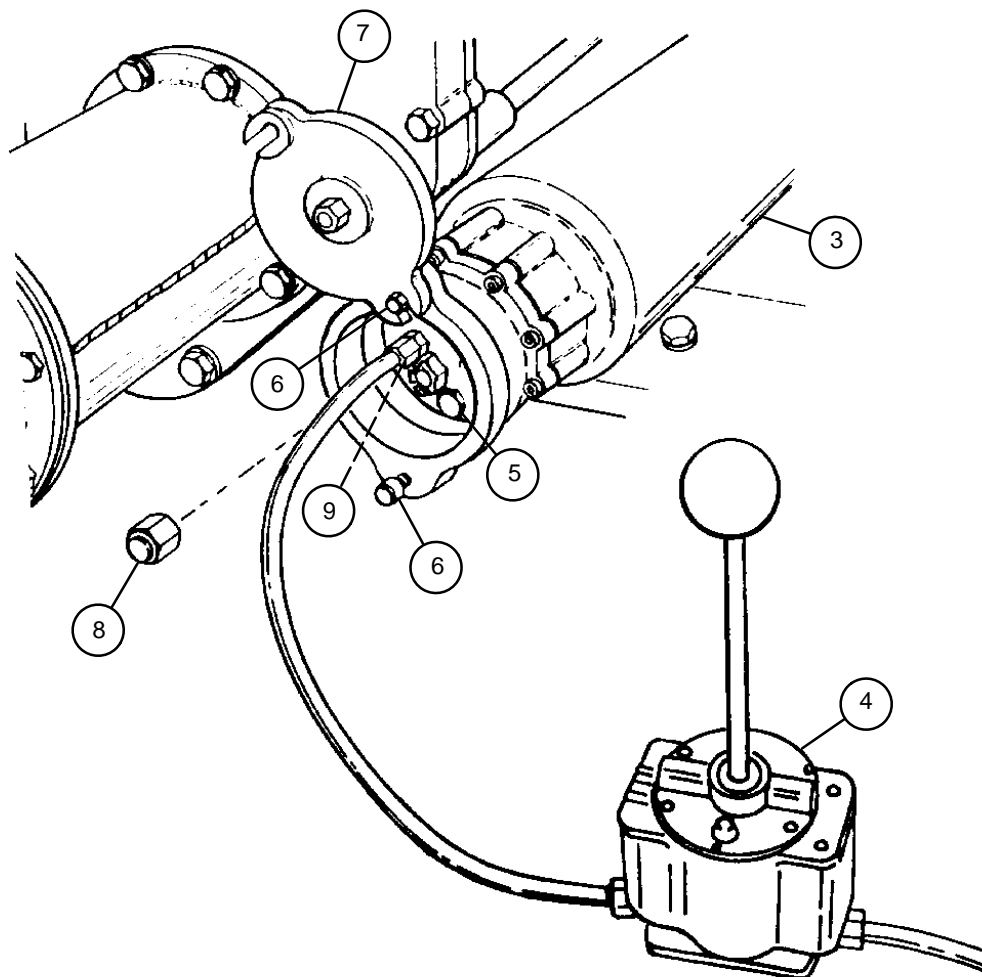
Loosen cap screws to stop pin before rotating cover to prevent damage to gasket.

- 4 Loosen two cap screws (6) at front end of recuperator cylinder (3).





- 5 Rotate cover (7) to the open position. Tighten top cap screw (6) to hold cover in open position.
- 6 Remove valve cap (8) from check valve (9).
- 7 Attach M3 oil pump (4) to check valve (9). Fill piston until two pins (5) extend not less than 1/8 inch (3.2 mm). Do not overfill (piston requires about 0.5 pint (0.2 l)). After filling, disconnect M3 oil pump.
- 8 Install valve cap (8).
- 9 Loosen top cap screw (6), then rotate cover (7) to the closed position.
- 10 Tighten two cap screws (6).



---

## 19–2 RECUPERATOR ASSEMBLY — CONTINUED

---

### b. Servicing with High Pressure Nitrogen – Method One

**WARNING**

Dry nitrogen tanks are marked with one or two black bands at the top of the tank. Do not use tanks without black band. In charging recuperator, use dry nitrogen. Certain other gases will cause recuperator cylinder to explode, resulting in possible death or serious injury.

**CAUTION**

Open and close nitrogen cylinder shut off valve to clear valve seat of any dust or dirt. Repeat operation after installation of pressure regulator to clear hose.

**NOTE**

Recuperator assembly must be serviced with hydraulic fluid before it is charged with dry nitrogen.

- 1 Attach nitrogen charging assembly (10) to nitrogen cylinder (11) as shown.
- 2 Remove nitrogen valve cap (12). Attach angle valve (13) of nitrogen charging assembly (10) to nitrogen valve (14), but do not tighten angle valve.
- 3 Close stop-check valve (15) and angle valve (16) of nitrogen charging assembly (10).
- 4 Open nitrogen cylinder (11) shutoff valve (17).
- 5 Open pressure regulator valve (18) slowly until 3000 psi gage (19) shows 15–20 psi (103–138 kPa), then close pressure regulator valve.
- 6 Open stop-check valve (15) on nitrogen charging assembly (10). Tighten angle valve (13) just before 3000 psi gage (19) registers 0 psi (0 kPa).

**NOTE**

Gage used in step 7, must be at least a 1000 psi gage.

- 7 Open nitrogen valve (14) and observe pressure on gage (20). Pressure should read  $700 \pm 25$  psi ( $4827 \pm 172$  kPa) at 70°F (21°C). If not, go to step 8.

**NOTE**

If recuperator cylinder is charged to  $700 \pm 25$  psi ( $4827 \pm 172$  kPa), go to step 11.

- 8 Open nitrogen cylinder (11) shutoff valve (17). Observe nitrogen cylinder 4000 psi gage (21). Pressure should be at least  $800 \pm 50$  psi ( $5516 \pm 345$  kPa).
- 9 Open pressure regulator valve (18) until 3000 psi gage (19) registers  $700 \pm 25$  psi ( $4827 \pm 172$  kPa) at 70°F (21°C).
- 10 Loosen nut on nitrogen valve (14) about 1 turn (2–1/4 turns provide maximum opening).

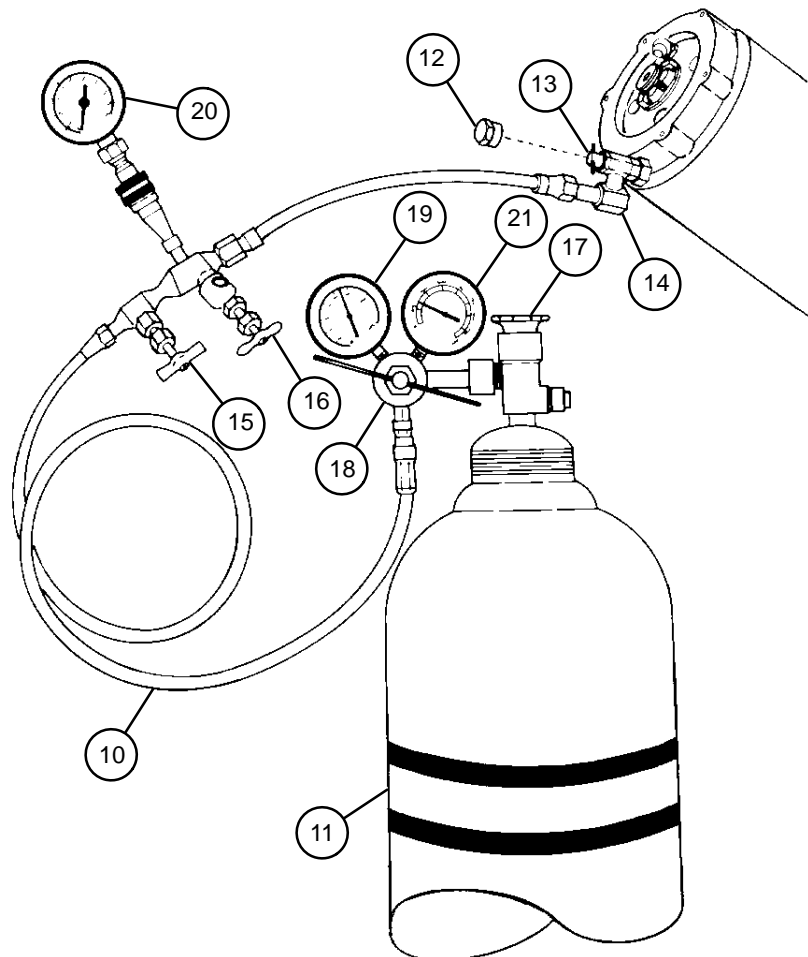
**CAUTION**

Charging the system too fast will heat the dry nitrogen. This will give an inaccurate reading because the pressure will decrease when the nitrogen cools, possibly causing equipment to malfunction.

**NOTE**

Estimated time to charge system is 30 minutes. System should be charged at ambient temperature of weapon use.

- 11 Tighten nut on nitrogen valve (14) when sound of nitrogen flow has stopped.
- 12 Close nitrogen cylinder (11) shutoff valve (17).
- 13 Open angle valve (16) on nitrogen charging assembly (10). Slowly relieve pressure in nitrogen charging assembly. Remove angle valve (13) from nitrogen valve (14).
- 14 Install nitrogen valve cap (12) on nitrogen valve (14).
- 15 Close pressure regulator valve (18).
- 16 Remove nitrogen charging assembly (10) from nitrogen cylinder (11).



---

## 19–2 RECUPERATOR ASSEMBLY — CONTINUED

---

### c. Servicing with High Pressure Nitrogen (Method Two)

#### NOTE

Recuperator assembly must be serviced with hydraulic fluid before it is charged with dry nitrogen.

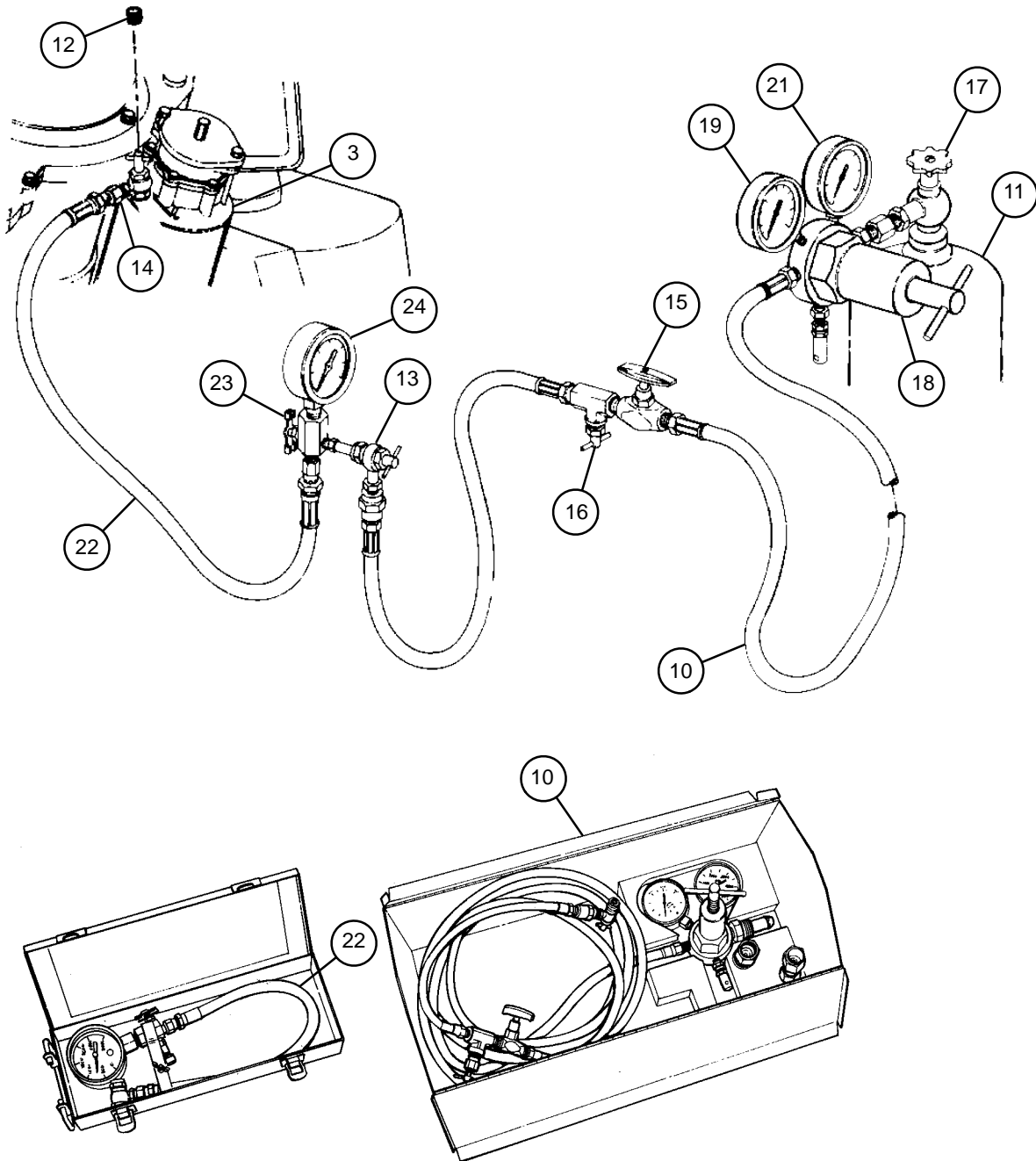
- 1 Connect and tighten nitrogen charging assembly (10) to nitrogen cylinder (11) as shown.

**WARNING**

Dry nitrogen tanks are marked with one or two black bands at the top of the tank. Do not use tanks without black band. In charging recuperator cylinder, use dry nitrogen. Certain other gases will cause recuperator cylinder to explode, resulting in possible death or serious injury.

**CAUTION**

- Open and close nitrogen cylinder shutoff valve to clear valve seat of any dust or dirt. Repeat operation after installation of pressure regulator to clear hose.
  - Cannon is shown elevated only for clarification. Cannon must be at zero elevation when checking or charging recuperator cylinder.
- 2 Remove nitrogen valve cap (12) from nitrogen valve (14).
  - 3 Connect air pressure gage assembly (22) to nitrogen valve (14) on recuperator cylinder (3).
  - 4 Connect nitrogen charging assembly (10) to air pressure gage assembly (22) as shown.
  - 5 Open angle valve (13).
  - 6 Close angle valve (16).
  - 7 Close safety-relief valve (23).
  - 8 Open nitrogen valve (14) by turning counterclockwise.
  - 9 Close pressure regulator valve (18) by turning counterclockwise until no spring pressure is felt.
  - 10 Open nitrogen cylinder (11) shutoff valve (17) slowly until full cylinder pressure is indicated on 4000 psi gage (21).
  - 11 Open pressure regulator valve (18) slowly, turning clockwise until pressure on 3000 psi gage (19) registers 50 psi (345 kPa).
  - 12 Open stop-check valve (15), allowing nitrogen to enter the recuperator cylinder (3) until gage (24) on the air pressure gage assembly (22) reads 50 psi (345 kPa). Close angle valve.



---

## 19-2 RECUPERATOR ASSEMBLY — CONTINUED

---

### c. Servicing with High Pressure Nitrogen (Method Two) — Continued

**CAUTION**

Charging the system too fast will heat the dry nitrogen. This will give an inaccurate reading because the pressure will decrease when the nitrogen cools, possibly causing equipment to malfunction.

**NOTE**

Estimated time to charge system is 30 minutes. System should be charged at ambient temperature of weapon use.

- 13 Open safety-relief valve (23) until all nitrogen is bled from recuperator cylinder (3); then close safety-relief valve.
- 14 Repeat steps 12 and 13 to remove all traces of moisture prior to charging system to full pressure with nitrogen.
- 15 Open pressure regulator valve (18) slowly, turning clockwise until pressure on 3000 psi gage (19) registers 100 psi (690 kPa) at 70°F (21° C).
- 16 Open stop-check valve (15) slowly, allowing nitrogen to charge recuperator assembly.
- 17 Open pressure regulator valve (18) to raise pressure at 100 psi (690 kPa) increments until gage (24) stabilizes at 700 psi (5171 kPa) at 70°F (21°C).

**WARNING**

Failure to close nitrogen valve on recuperator cylinder could result in injury to personnel from high pressure gas.

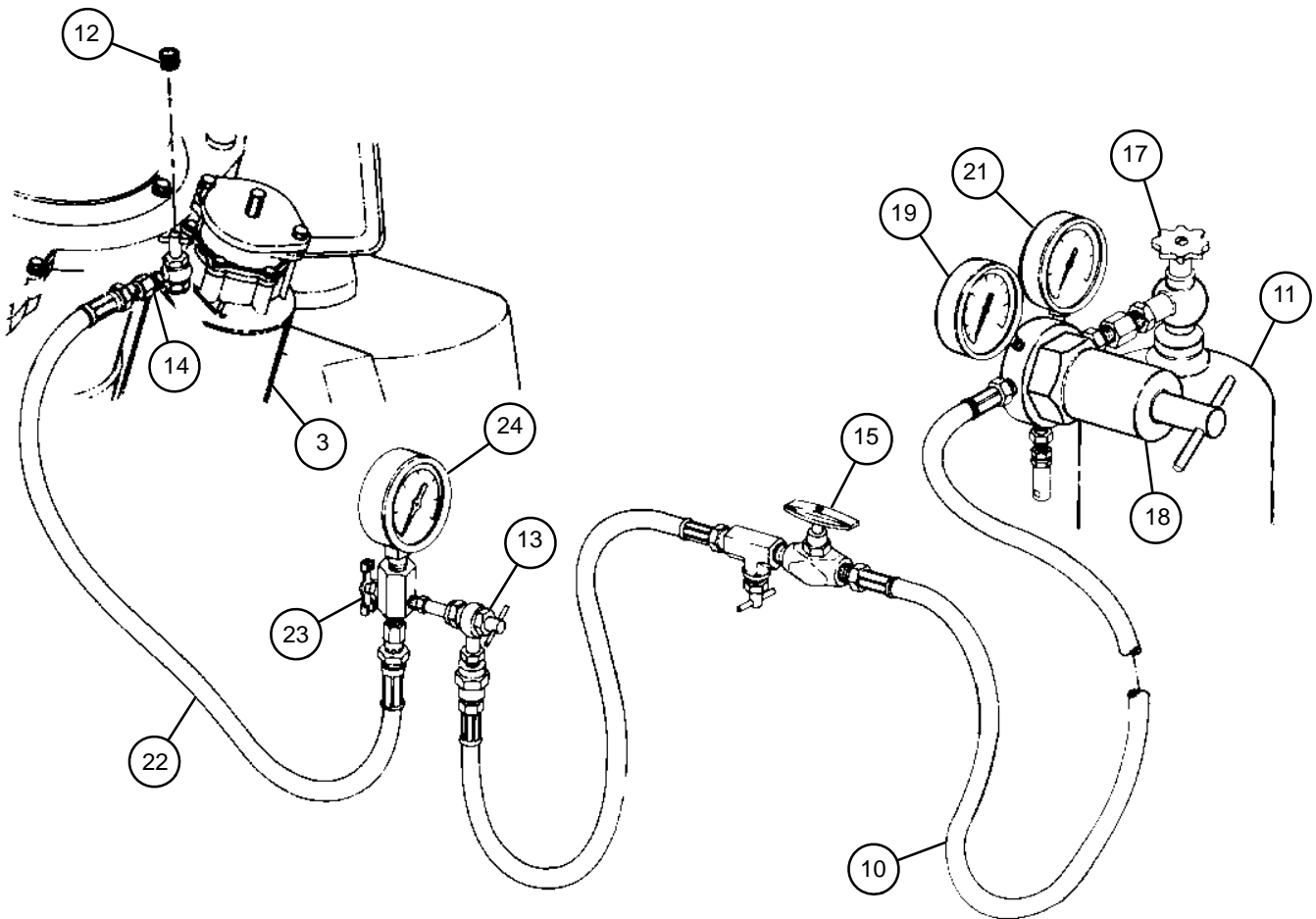
- 18 Close nitrogen valve (14) and shutoff valve (17). Let system set for one hour after charging.

**WARNING**

Failure to open safety-relief valve could result in injury.

- 19 Open safety-relief valve (23) to bleed pressure from nitrogen charging assembly (10) and air pressure gage assembly (22).
- 20 Disconnect nitrogen charging assembly (10) and air pressure gage assembly (22) at angle valve (13).
- 21 Close pressure regulator valve (18) by turning counterclockwise.
- 22 Disconnect nitrogen charging assembly (10) from shutoff valve (17).
- 23 After one hour wait, close safety-relief valve (23).

- 24 Slowly open nitrogen valve (14). Read gage (24) to determine if leakage has occurred. If no leakage is detected, slowly open safety-relief valve (23), releasing pressure in recuperator cylinder (3) to 700 psi (4827 kPa).
- 25 Close nitrogen valve (14).
- 26 Slowly open safety-relief valve (23).
- 27 Disconnect air pressure gage assembly (22) from nitrogen valve (14) on recuperator cylinder (3).
- 28 Apply soap suds to nitrogen valve (14) to check for nitrogen leaks. If leaks occur, tighten nitrogen valve. If leaks are still present, release nitrogen pressure and replace defective nitrogen valve.
- 29 If no leaks are present, replace nitrogen valve cap (12).
- 30 Apply soap suds to both ends of recuperator cylinder (3) to determine if nitrogen leaks exist. Notify support maintenance if leaks are present.



---

## 19-3 ACCUMULATOR ASSEMBLY, MANUAL PUMP

---

This task covers:    a. Service (Method One)                    b. Service (Method Two)

---

### INITIAL SETUP

Tools

Artillery and turret mechanic's tool kit

(SC 5180-95-CL-A12)

Drain pan (item 8, Appx H)

Nitrogen charging kit (item 3, Appx H)

Materials/Parts

Dry nitrogen (item 22, Appx D)

Soap (item 33, Appx D)

---

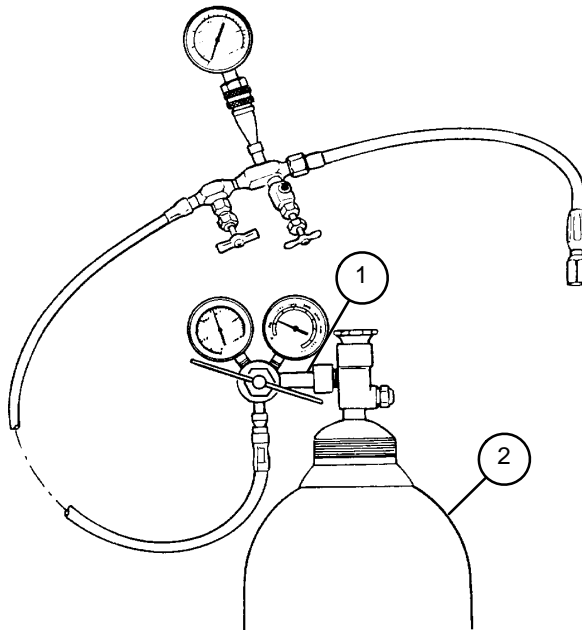
#### a. Service (Method One)

- 1 If accumulator is installed in vehicle, relieve pressure in hydraulic system (para 6-3).
- 2 Disconnect the two lower hydraulic tubes at the elevating mechanism locking valve. Catch the hydraulic fluid in a drain pan.

**WARNING**

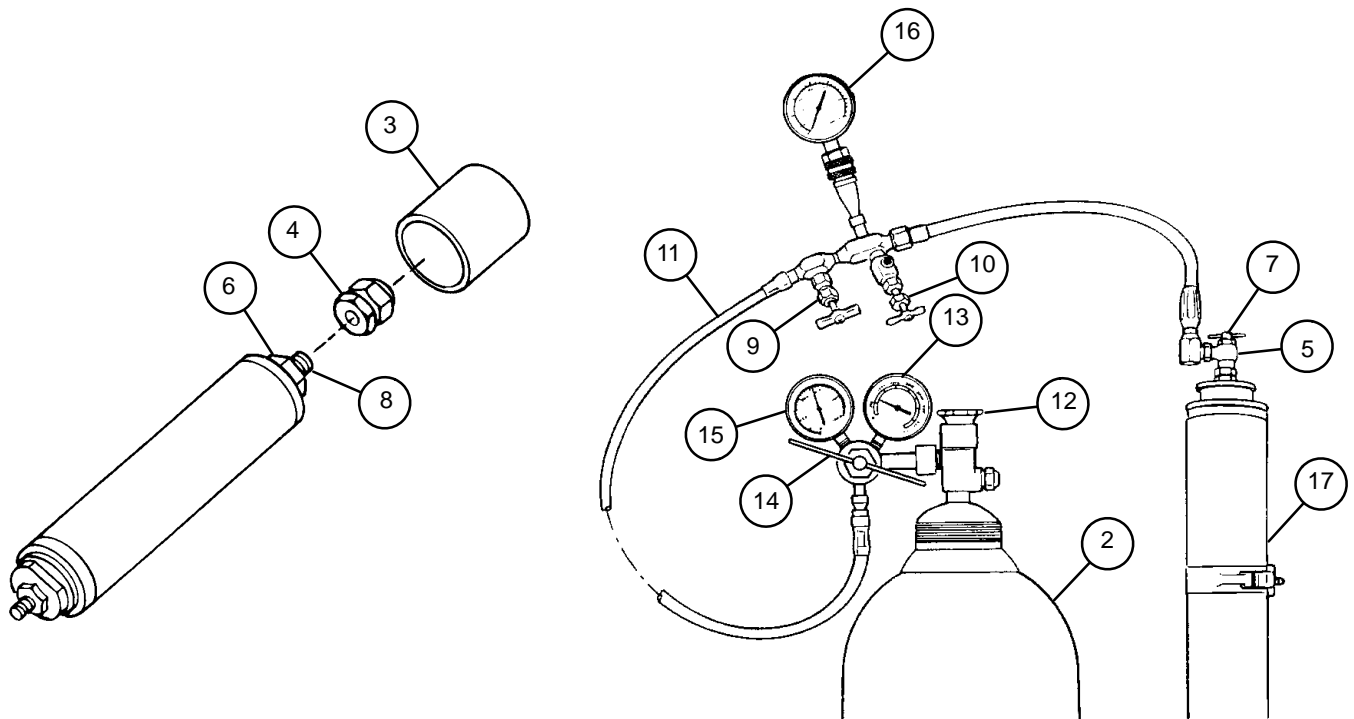
Make sure charging cylinder contains dry nitrogen. Dry nitrogen tanks are marked with one or two black bands. Certain other gases can cause accumulator to explode, resulting in possible injury.

- 3 Attach regulator (1) to nitrogen cylinder (2) as shown and tighten.





- 4 Remove accumulator cap (3) and air valve cap (4).
- 5 Attach angle valve (5) to valve body (6), but do not tighten. Back out stem (7) of angle valve until stem no longer contacts valve core (8).
- 6 Close stop-check valve (9) and angle valve (10) of nitrogen charging assembly (11).
- 7 Open nitrogen cylinder (2) shutoff valve (12) and observe nitrogen cylinder 4000 psi gage (13). Pressure must be greater than 90 psi (620 kPa).
- 8 Open pressure regulator angle valve (14) until 3000 psi gage (15) reaches 15–20 psi (103–138 kPa), then close pressure regulator valve.
- 9 Open stop-check valve (9) and tighten angle valve (5) just before 3000 psi gage (15) reaches zero.
- 10 Open pressure regulator valve (14) until gage (16) reaches 75–90 psi (517–620 kPa).
- 11 Turn in stem (7) of angle valve (5) (clockwise) until nitrogen begins to enter accumulator (17). Allow accumulator to fill slowly.
- 12 Close pressure regulator valve (14) when sound of nitrogen flowing into accumulator (17) has stopped.
- 13 Back out stem (7) of valve (5) all the way (counterclockwise).
- 14 Open angle valve (10) slowly to release pressure in the nitrogen charging assembly (11).
- 15 Remove angle valve (5) from accumulator (17).
- 16 Apply soap suds to fittings of accumulator (17) to determine if nitrogen leaks exist. Notify support maintenance if leaks are present.



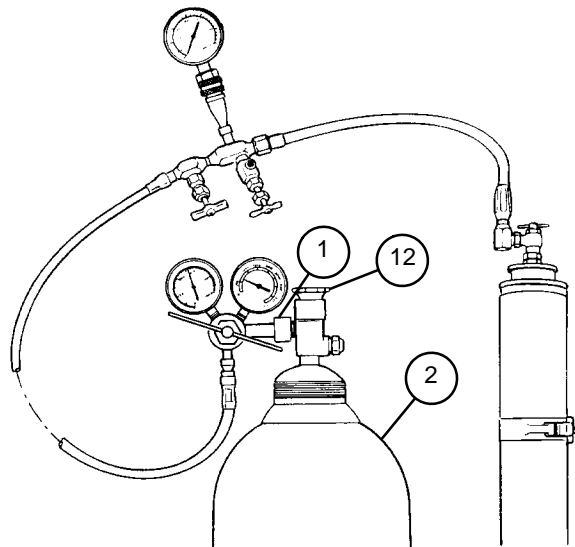
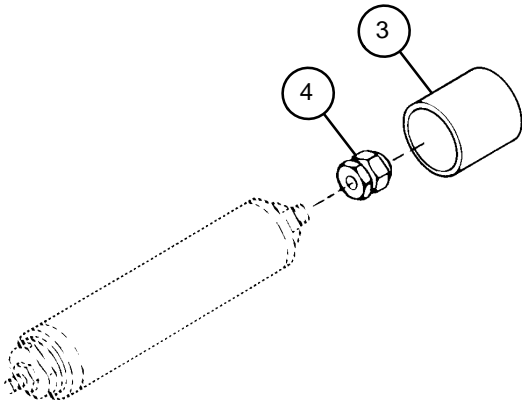
---

## 19-3 ACCUMULATOR ASSEMBLY, MANUAL PUMP — CONTINUED

---

### a. Service (Method One) — Continued

- 17 Install air valve cap (4) and accumulator cap (3).
- 18 Close nitrogen cylinder (2) shutoff valve (12) by turning clockwise.
- 19 Remove regulator (1) from nitrogen cylinder (2).
- 20 Connect elevating cylinder hydraulic lines to locking valve and tighten hex nuts if accumulator is mounted in vehicle.
- 21 Refill, charge and bleed hydraulic system (para 6-3).



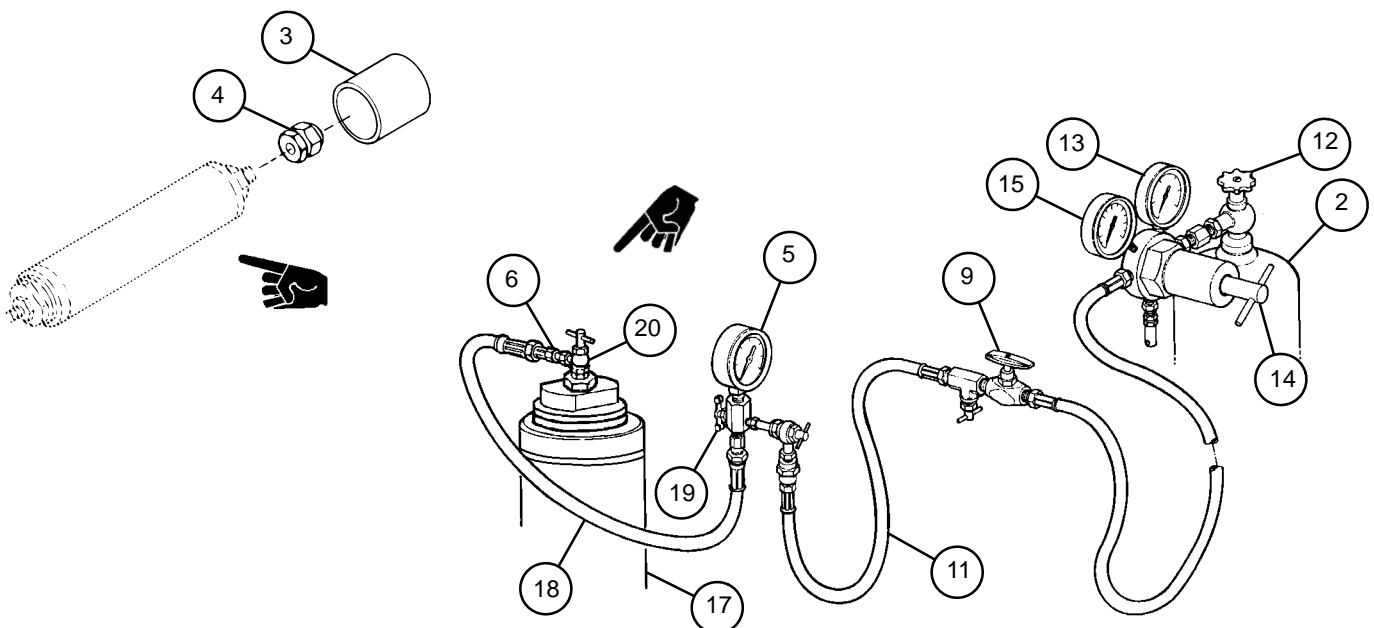
**b. Service (Method Two)**

- 1 Remove cab access cover if accumulator is installed in cab (para 14-11).
- 2 Discharge pressure in hydraulic system (para 6-3).

**WARNING**

Accumulator contains high pressure nitrogen. Use caution when handling and working with it to avoid injury.

- 3 Open and close nitrogen cylinder (2) shutoff valve (12) to clear valve seat of any dust or dirt. Repeat this operation after installation of pressure regulator to clear hose.
- 4 Connect and tighten nitrogen charging assembly (11) to nitrogen cylinder (2) as shown.
- 5 Remove accumulator cap (3) and air valve cap (4). Connect air pressure gage assembly (18) to valve body (6) on accumulator (17).
- 6 Connect nitrogen charging assembly (11) to air pressure gage assembly (18).
- 7 Open angle valve (5).
- 8 Close stop-check valve (9).
- 9 Close safety-relief valve (19).
- 10 Open angle valve (20) by turning clockwise.
- 11 Close pressure regulator valve (14) by turning counterclockwise until no spring pressure is felt.
- 12 Open nitrogen cylinder (2) shutoff valve (12) slowly until full cylinder pressure is indicated on 4000 psi gage (13) of pressure indicator.
- 13 Open pressure regulator valve (14) slowly, turning it clockwise until pressure on 3000 psi gage (15) registers 50 psi (345 kPa).



---

**19–3 ACCUMULATOR ASSEMBLY, MANUAL PUMP — CONTINUED**

---

**b. Service (Method Two) — Continued**

- 14 Open stop-check valve (9), allowing nitrogen to enter the accumulator (17) until gage (21) on the air pressure gage assembly (18) reads 50 psi (345 kPa).
- 15 Close stop-check valve (9).
- 16 Open safety-relief valve (19) until all nitrogen is bled from accumulator (17), then close safety-relief valve.
- 17 Repeat steps 14 through 16 to remove all traces of moisture prior to charging system to full pressure. Re-open stop-check valve (9).

**CAUTION**

Changing the system too fast will heat the dry nitrogen. This will give an inaccurate reading because the pressure will decrease when the nitrogen cools possibly causing equipment to malfunction.

**NOTE**

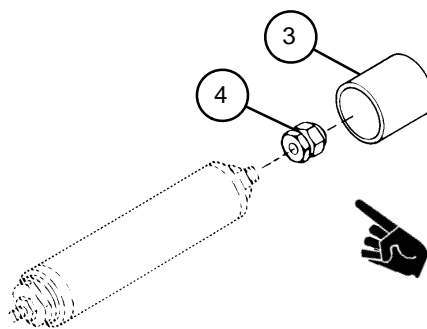
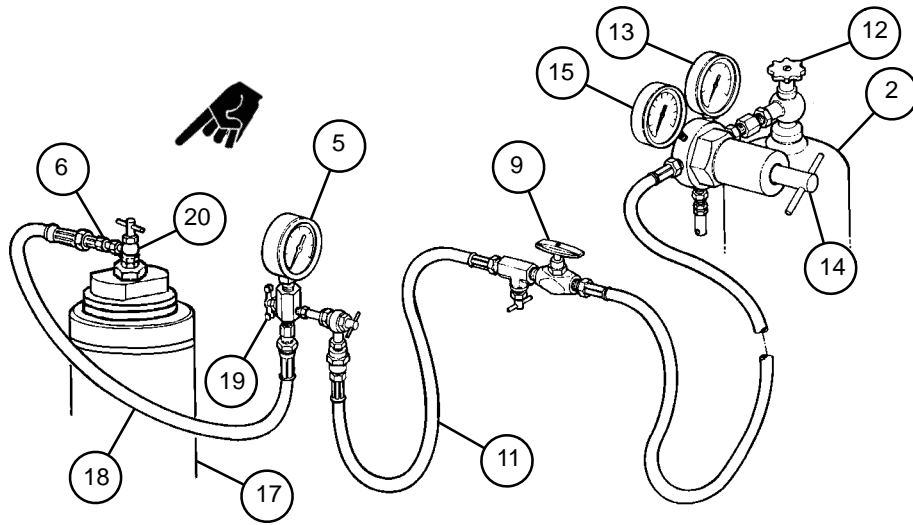
Estimated time to charge system is 30 minutes or more. System should be charged at ambient temperature of weapon use.

- 18 Open pressure regulator valve (14) slowly, turning clockwise until pressure on 3000 psi gage (15) registers 110 psi (758 kPa) at 70°F (21°C).
- 19 Open stop-check valve (9) slowly, allowing nitrogen to charge system.

**WARNING**

- Failure to close check valve on main accumulator and pressure regulator valve could result in injury from high pressure in hoses of nitrogen charging assembly and air pressure gage assembly.
  - Failure to open safety-relief valve could result in injury from high pressure trapped in hoses of nitrogen charging assembly and air pressure gage assembly.
- 20 Close angle valve (20) and nitrogen cylinder (2) shutoff valve (12). Let system remain idle for one hour after charging.
  - 21 Open safety-relief valve (19) to bleed pressure from nitrogen charging assembly (11) and air pressure gage assembly (18).
  - 22 Disconnect nitrogen charging assembly (11) and air pressure gage assembly (18) at angle valve (5).
  - 23 Close pressure regulator valve (14) by turning counterclockwise.
  - 24 Disconnect nitrogen charging assembly (11) from nitrogen cylinder (2) shutoff valve (12).
  - 25 Close safety-relief valve (19).

- 26 Open angle valve (20).
- 27 Slowly open safety-relief valve (19), reducing pressure to 90 psi (620 kPa) on accumulator (17), then close safety-relief valve.
- 28 Close angle valve (20).
- 29 Open safety-relief valve (19).
- 30 Disconnect air pressure gage assembly (18) from valve body (6) on accumulator (17).
- 31 Apply soap suds to fittings of accumulator (17) to determine if nitrogen leaks exist. Notify support maintenance if leaks are present.
- 32 Replace valve cap (4).
- 33 Replace accumulator cap (3).



---

## 19-4 ACCUMULATOR ASSEMBLY, MAIN

---

This task covers:    a. Service (Method One)                    b. Service (Method Two)

---

### **INITIAL SETUP**

#### Tools

Artillery and turret mechanic's tool kit  
(SC 5180-95-CL-A12)  
Nitrogen charging kit (item 3, Appx H)  
Purging kit, fire control (item 4, Appx H)

#### Materials/Parts

Dry nitrogen (item 22, Appx D)

#### Equipment Condition

If accumulator is installed in cab:  
Cab access cover removed (para 14-11)  
Discharge hydraulic pressure (para 6-3)

---

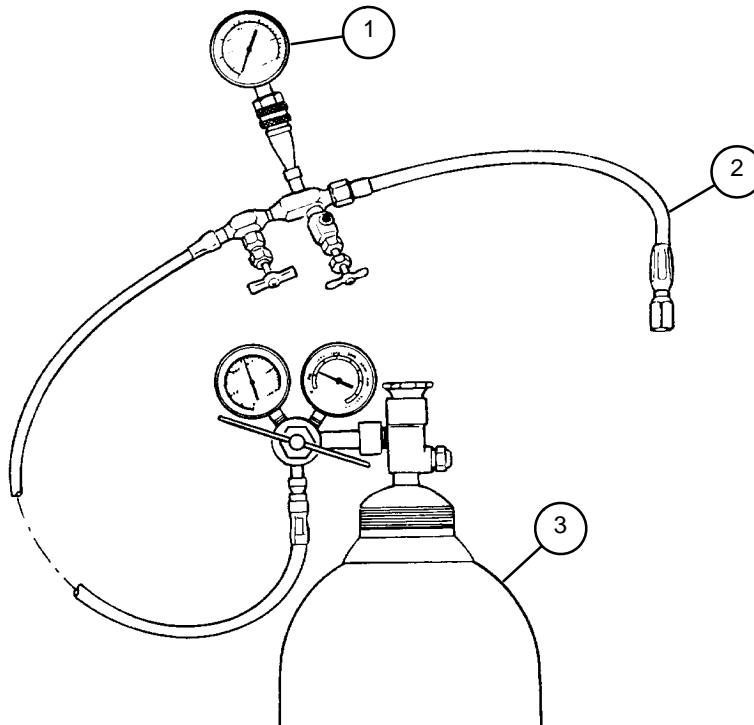
### **a. Service (Method One)**

- 1 Remove gage (1) from nitrogen charging assembly (2).

**WARNING**

Accumulator contains high pressure nitrogen. Use caution when handling and working with it to avoid injury.

- 2 Attach and tighten nitrogen charging assembly (2) to nitrogen cylinder (3) as shown.

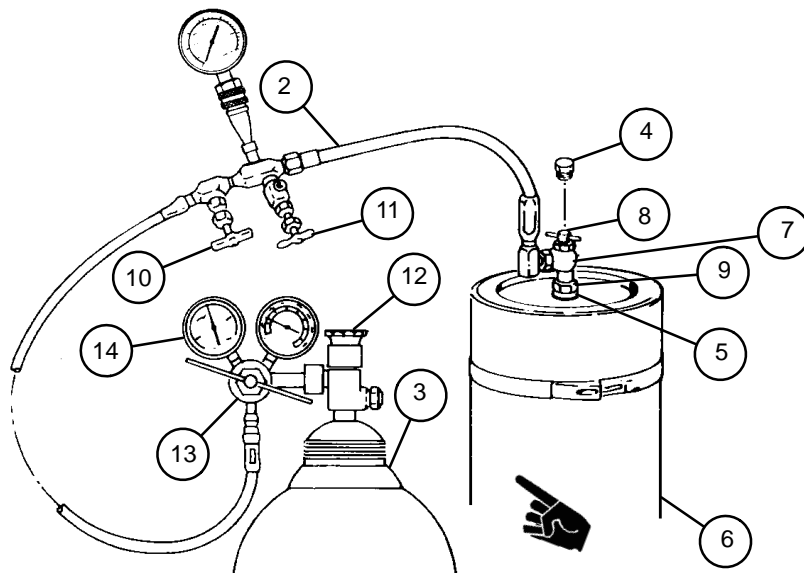


- 3 Remove air valve cap (4) from valve body (5). If valve body cannot be reached directly when accumulator (6) is installed in cab, use accumulator charging extension valve.

**NOTE**

Be sure ports in bottom cylinder cap are not blocked or plugged.

- 4 Attach angle valve (7) to valve body (5), but do not tighten. Back out stem (8) of angle valve until stem no longer contacts valve core (9).
- 5 Open stop-check valve (10) and close angle valve (11). Open shutoff valve (12).
- 6 Open pressure regulator valve (13) until 3000 psi gage (14) registers 15 to 20 psi (103 to 138 kPa), then close pressure regulator valve.
- 7 Tighten angle valve (7) just before 3000 psi gage (14) registers 0 psi (0 kPa).
- 8 Turn stem (8) of angle valve (7) clockwise to open valve core (9).
- 9 Open pressure regulator valve (13) by turning handle clockwise until 3000 psi gage (14) registers 500 to 550 psi (3448 to 3792 kPa).
- 10 Close pressure regulator valve (13) when sound of nitrogen flowing into accumulator (6) has stopped.
- 11 Back out stem (8) of angle valve (7) all the way by turning counterclockwise, thereby closing valve core (9).
- 12 Open angle valve (11) slowly to release pressure in the nitrogen charging assembly (2).
- 13 Remove angle valve (7) from accumulator (6).
- 14 Install air valve cap (4) on accumulator (6).
- 15 Close shutoff valve (12) by turning it clockwise.
- 16 Remove nitrogen charging assembly (2) from nitrogen cylinder (3).



---

**19–4 ACCUMULATOR ASSEMBLY, MAIN — CONTINUED**

---

**b. Service (Method Two)**

<b>WARNING</b>
----------------

Accumulator contains high pressure nitrogen. Use caution when handling and working with it to avoid injury.

- 1 Open and close shutoff valve (12) to clear valve seat of any dust or dirt. Repeat this operation after installation of pressure regulator to clear hose.
- 2 Connect and tighten nitrogen charging assembly (2) to nitrogen cylinder (3) as shown.
- 3 Remove air valve cap (4). Connect air pressure gage assembly (15) to valve body (5) on accumulator (6).
- 4 Connect nitrogen charging assembly (2) to air pressure gage assembly (15).
- 5 Open angle valve (7).
- 6 Close stop-check valve (10).
- 7 Close safety-relief valve (16).
- 8 Open angle valve (17) by turning clockwise.
- 9 Close pressure regulator valve (13) by turning counterclockwise until no spring pressure is felt.
- 10 Open shutoff valve (12) slowly until full cylinder pressure is indicated on 4000 psi gage (18) of pressure indicator.
- 11 Open pressure regulator valve (13) slowly, turning it clockwise until pressure on 3000 psi gage (14) registers 50 psi (345 kPa).
- 12 Open stop-check valve (10), allowing nitrogen to enter the accumulator (6) until gage (19) on the air pressure gage assembly (15) reads 50 psi (345 kPa).
- 13 Close stop-check valve (10).
- 14 Open safety-relief valve (16) until all nitrogen is bled from accumulator (6), then close safety-relief valve.
- 15 Repeat steps 10 and 11 to remove all traces of moisture prior to charging system to full pressure. Reopen stop-check valve (10).

**NOTE**

Charging the system too fast will heat the dry nitrogen. This will give an inaccurate reading because the pressure will decrease when the nitrogen cools. Estimated time to charge system is 30 minutes or more. System should be charged at ambient temperature of weapon use.

- 16 Open pressure regulator valve (13) slowly, turning clockwise until pressure on 3000 psi gage (14) registers 550 psi (3792 kPa).



- 17 Open stop-check valve (10) slowly, allowing nitrogen to charge system. Raise pressure in 100 psi (690 kPa) increments until gage (19) stabilizes at 550 psi (3792 kPa).

**WARNING**

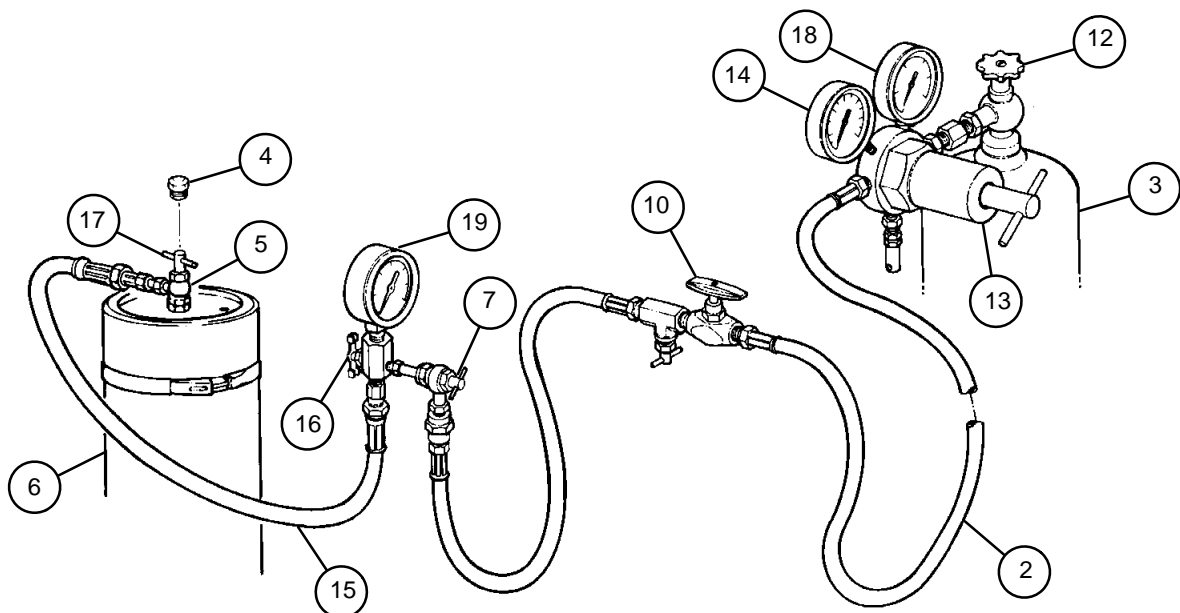
Failure to close angle valve on main accumulator and pressure regulator valve could result in injury from high pressure in hoses of nitrogen charging assembly and air pressure gage assembly.

- 18 Close angle valve (17) and shutoff valve (12). Let system remain idle for one hour after charging.

**WARNING**

Failure to open safety-relief valve could result in injury from high pressure trapped in hoses of nitrogen charging assembly and air pressure gage assembly.

- 19 Open safety-relief valve (16) to bleed pressure from nitrogen charging assembly (2) and air pressure gage assembly (15).
- 20 Disconnect nitrogen charging assembly (2) and air pressure gage assembly (15) at angle valve (7).
- 21 Close pressure regulator valve (13) by turning counterclockwise.
- 22 Disconnect nitrogen charging assembly (2) from shutoff valve (12).
- 23 Close safety-relief valve (16).
- 24 Open angle valve (17).
- 25 Slowly open safety-relief valve (16), reducing pressure to 500 psi (3448 kPa) on accumulator (6), then close safety-relief valve.
- 26 Close angle valve (17).
- 27 Open safety-relief valve (16).
- 28 Disconnect air pressure gage assembly (15) from valve body (5) on accumulator (6).
- 29 Replace air valve cap (4).



---

## 19-5 ACCUMULATOR ASSEMBLY, PRIMARY

---

This task covers:    a. Service (Method One)                      b. Service (Method Two)

---

### **INITIAL SETUP**

#### Tools

Artillery and turret mechanic's tool kit  
(SC 5180-95-CL-A12)  
Nitrogen charging kit (item 3, Appx H)

#### Materials/Parts

Dry nitrogen (item 22, Appx D)  
Hydraulic fluid, OHT (item 21, Appx D)

#### Equipment Condition

Discharge hydraulic pressure (para 6-3.1)

---

### **a. Service (Method One)**

#### **NOTE**

Primary accumulator assembly may be charged while mounted in cab.

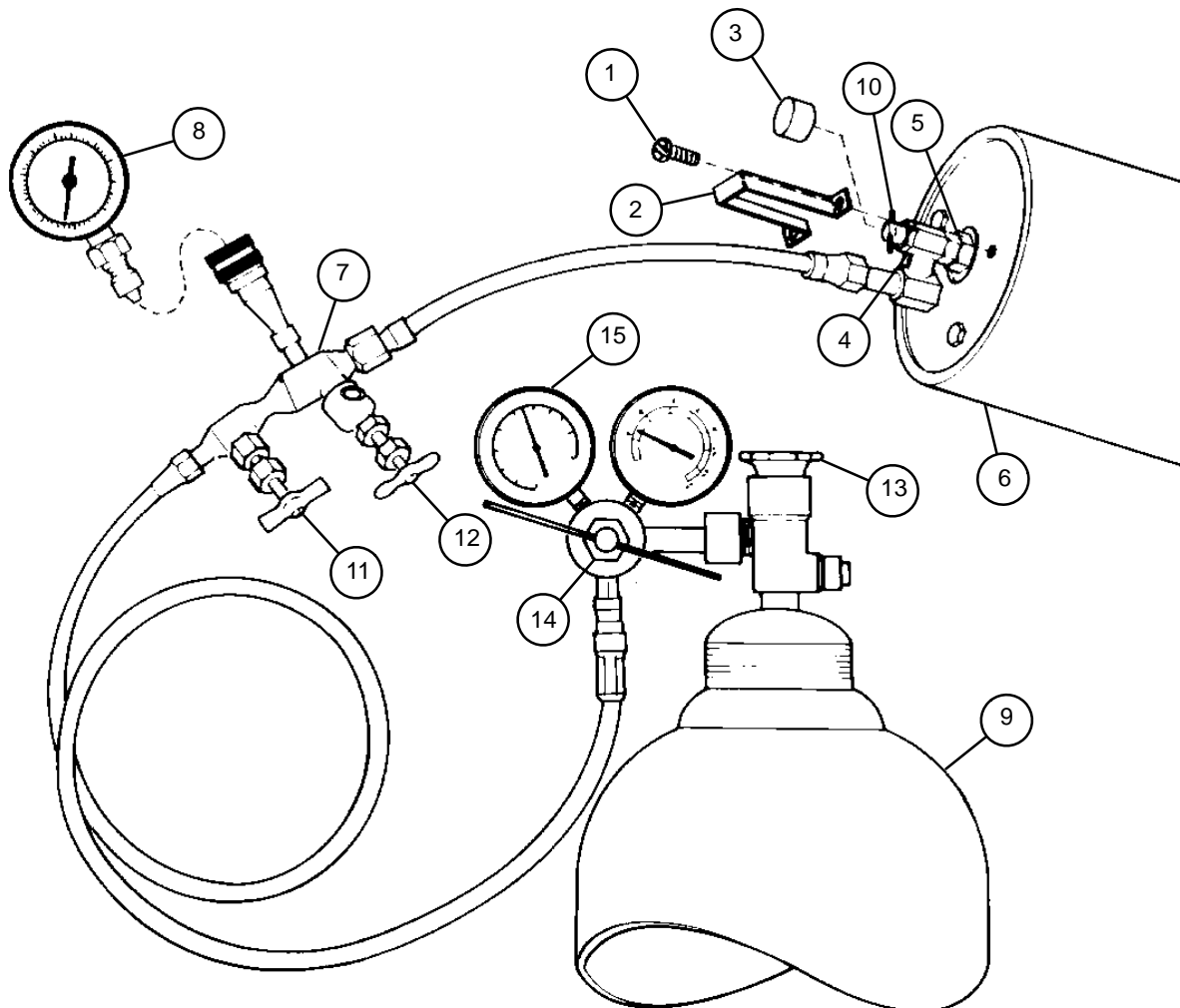
- 1 Remove two cap screws (1) and retaining strap (2).
- 2 Remove air valve cap (3) and loosen check valve nut (4) on valve (5) to release nitrogen precharge pressure from primary accumulator assembly (6).
- 3 Obtain nitrogen charging assembly (7) and remove gage (8).

#### **WARNING**

Accumulator contains high pressure nitrogen. Use caution when handling and working with it to avoid injury.

- 4 Connect nitrogen charging assembly (7) to primary accumulator assembly (6) and nitrogen cylinder (9).
- 5 Attach angle valve (10) of nitrogen charging assembly (7) to valve (5), but do not tighten angle valve. Close stop-check valve (11) and angle valve (12).
- 6 Open shutoff valve (13) on nitrogen cylinder (9).
- 7 Slowly open pressure regulator valve (14) until 3000 psi gage (15) shows 15-20 psi (103-138 kPa). Close pressure regulator valve.
- 8 Open stop-check valve (11) on nitrogen charging assembly (7). Tighten angle valve (10) just before 3000 psi gage (15) register 0 psi (0 kPa).
- 9 Loosen check valve nut (4) approximately one turn (2-1/4 turns is fully open).
- 10 Open pressure regulator valve (14) until 3000 psi gage (15) registers 900 ± 50 psi (6206 ± 345 kPa).
- 11 Tighten check valve nut (4) when sound of nitrogen flow has stopped.
- 12 Close pressure regulator valve (14).

- 13 Slowly open angle valve (12) to release pressure in nitrogen charging assembly (7). Remove angle valve (10) from valve (5).
- 14 Install air valve cap (3) on valve (5).
- 15 Close shutoff valve (13) on nitrogen cylinder (9).
- 16 Remove nitrogen charging assembly (7) from nitrogen cylinder (9) and primary accumulator assembly (6).
- 17 Install gage (8) on nitrogen charging assembly (7).
- 18 Install retaining strap (2) and two cap screws (1).



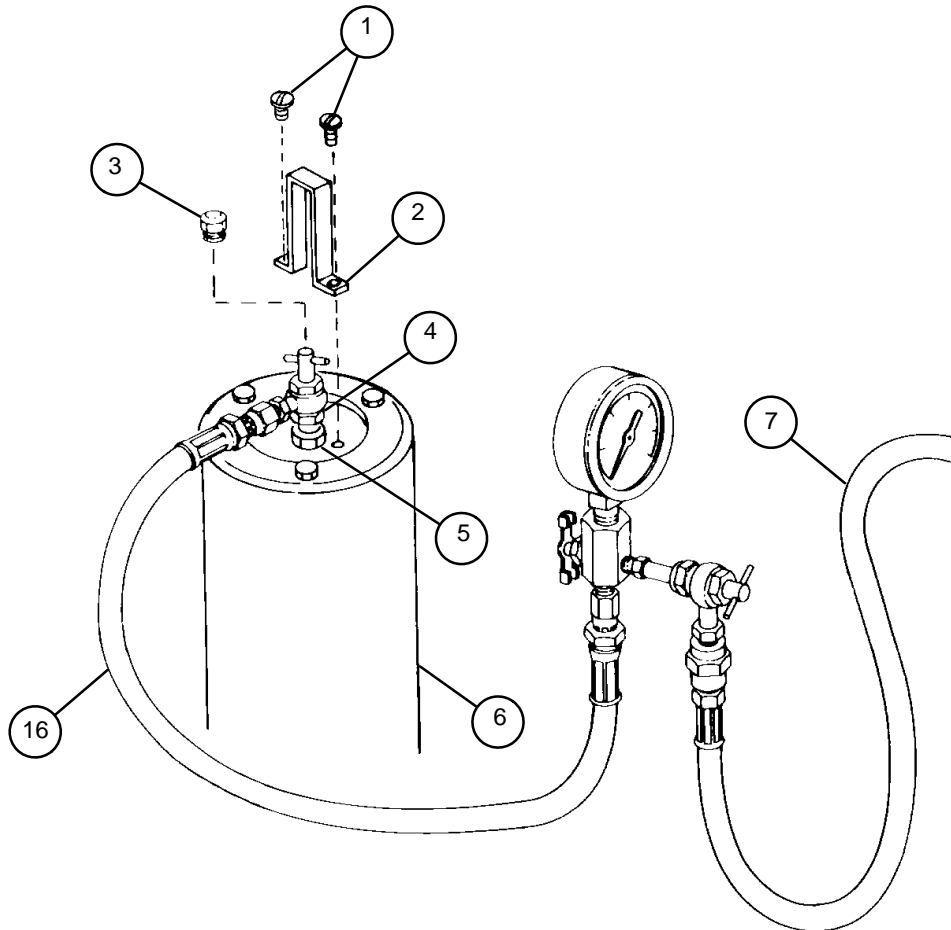
## 19-5 ACCUMULATOR ASSEMBLY, PRIMARY — CONTINUED

### b. Service (Method Two)

**WARNING**

Be sure nitrogen cylinder contains only dry nitrogen. Certain other gases will cause nitrogen cylinder or accumulator to explode, resulting in possible injury.

- 1 Remove two cap screws (1) and retaining strap (2).
- 2 Remove air valve cap (3) and loosen check valve nut (4) on valve (5) to release nitrogen precharge pressure from primary accumulator assembly (6).
- 3 Open and close nitrogen cylinder (9) shutoff valve (13) to clear shutoff valve seat of any dust or dirt.
- 4 Connect and tighten nitrogen charging assembly to nitrogen cylinder (9), as shown. Repeat operation to clear nitrogen charging assembly (7) hose.
- 5 Connect air pressure gage assembly (16) to valve (5) on primary accumulator assembly (6).

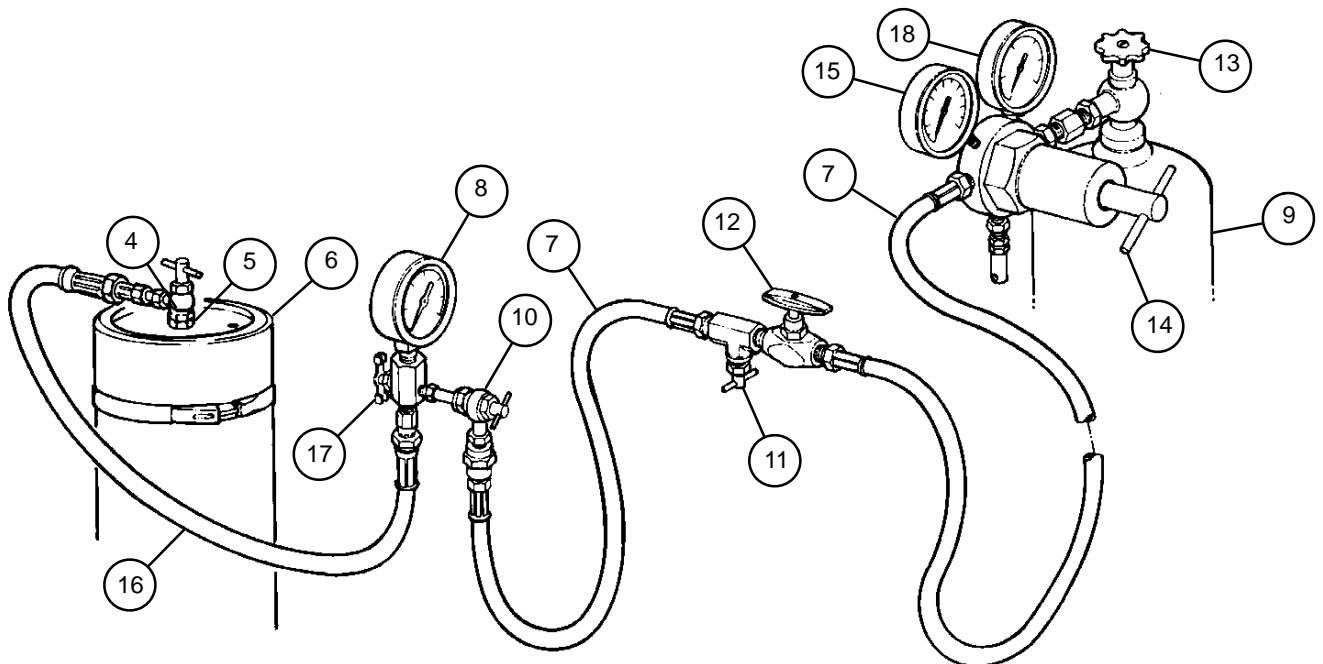


- 6 Connect nitrogen charging assembly (7) to air pressure gage assembly (16).
- 7 Open angle valve (10).
- 8 Close stop-check valve (11).
- 9 Close safety-relief valve (17).
- 10 Open valve (5) on primary accumulator assembly (6) by turning check valve nut (4) counterclockwise.
- 11 Turn pressure regulator valve (14) counterclockwise until no spring pressure is felt.
- 12 Open shutoff valve (13) slowly until full cylinder pressure is indicated on 4000 psi gage (18) of pressure regulator valve (14).
- 13 Open pressure regulator valve (14) slowly, turning clockwise until pressure on 3000 psi gage (15) reads 50 psi (345 kPa).
- 14 Open angle valve (12), allowing dry nitrogen to enter primary accumulator assembly (6) until pressure gage (8) on air pressure gage assembly (16) reads 50 psi (345 kPa). Close angle valve.
- 15 Open safety-relief valve (17) until all dry nitrogen is bled from primary accumulator assembly (6). Close safety-relief valve.
- 16 Repeat steps 13 and 14 to remove all traces of moisture prior to charging system to full pressure with dry nitrogen.

**CAUTION**

Charging system too fast will heat dry nitrogen. This will give inaccurate reading because pressure will decrease when nitrogen cools.

- 17 Open pressure regulator valve (14) slowly turning clockwise until pressure on 3000 psi gage (15) reads 950 psi (6550 kPa) at 70°F (21°C).



---

**19–5 ACCUMULATOR ASSEMBLY, PRIMARY — CONTINUED**

---

**b. Service (Method Two) — Continued****NOTE**

Estimated time required to charge system is 30 minutes or more. System should be charged at ambient temperature of weapon.

- 18 Open angle valve (12) slowly, allowing dry nitrogen to charge system. Raise pressure in 100 psi (690 kPa) increments until gage (8) on air pressure gage assembly (16) stabilizes at 950 psi (6550 kPa) at 70°F (21°C).

**WARNING**

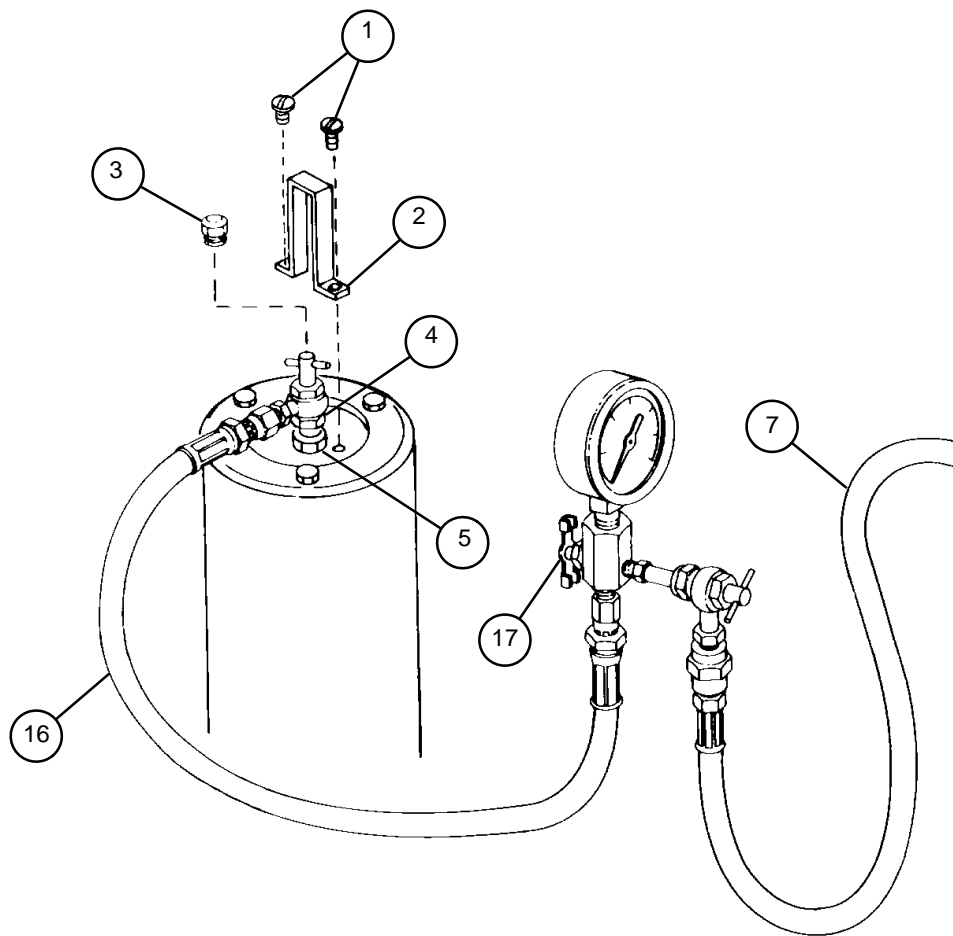
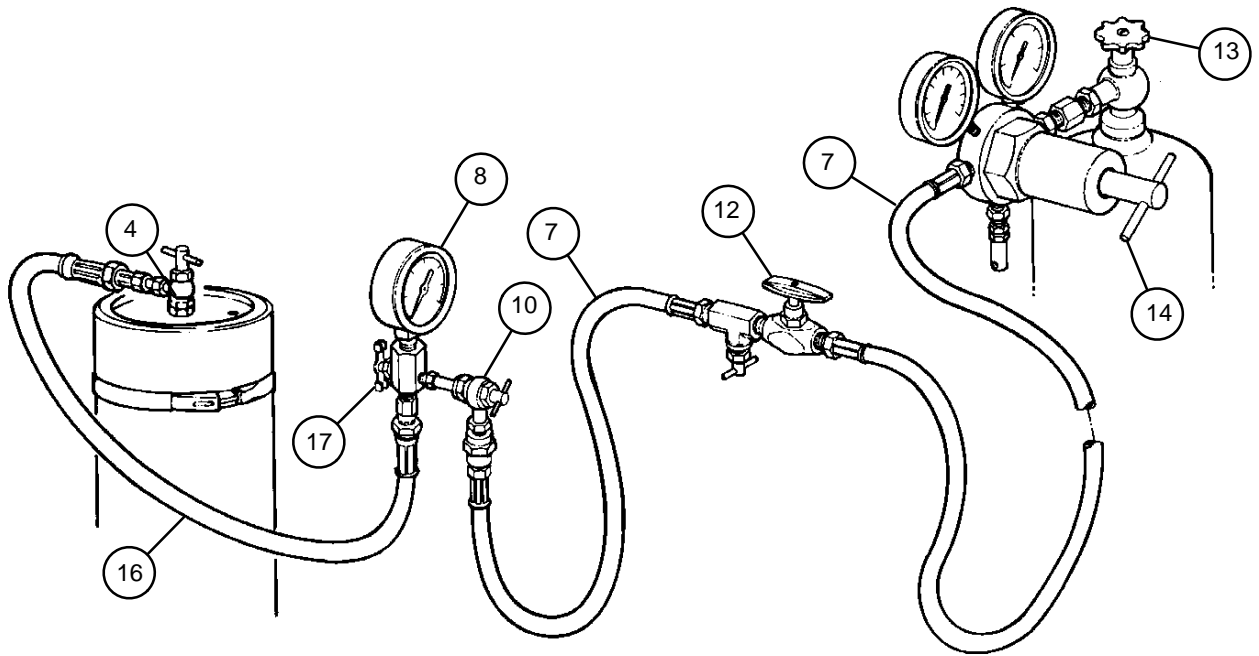
Failure to close check valve nut on primary accumulator assembly could result in injury to personnel from high pressure gas.

- 19 Close check valve nut (4) and shutoff valve (13). Let system remain idle for at least one hour after charging.

**WARNING**

Failure to open safety-relief valve could result in injury from high pressure trapped in hoses.

- 20 Open safety-relief valve (17) to bleed pressure from nitrogen charging assembly (7) and air pressure gage assembly (16).
- 21 Disconnect nitrogen charging assembly (7) and nitrogen pressure checking device (16) at angle valve (10).
- 22 Close pressure regulator valve (14) by turning counterclockwise.
- 23 Disconnect nitrogen charging assembly (7) from shutoff valve (13).
- 24 Close safety-relief valve (17).
- 25 Open check valve nut (4).
- 26 Slowly open safety-relief valve (17), reducing pressure to 900 psi (6206 kPa). Close safety-relief valve.
- 27 Close check valve nut (4) by turning clockwise.
- 28 Open safety-relief valve (17).
- 29 Disconnect air pressure gage assembly (16) from valve (5).
- 30 Install air valve cap (3) on valve (5).
- 31 Install two cap screws (1) and retaining strap (2).



## 19-6 ACCUMULATOR ASSEMBLY, SECONDARY

This task covers: a. Service (Method One) b. Service (Method Two)

### INITIAL SETUP

Tools

Artillery and turret mechanic's tool kit  
(SC 5180-95-CL-A12)

Nitrogen charging kit (item 3, Appx H)

Materials/Parts

Dry nitrogen (item 22, Appx D)

Equipment Condition

Discharge hydraulic pressure (para 6-3.1)

### a. Service (Method One)

#### NOTE

Secondary accumulator assembly may be charged while mounted in cab.

- 1 Remove two cap screws (1) and retaining strap (2).
- 2 Remove air valve cap (3) and loosen check valve nut (4) on valve (5) to release nitrogen precharge pressure from secondary accumulator assembly (6).
- 3 Obtain nitrogen charging assembly (7) and remove gage (8).

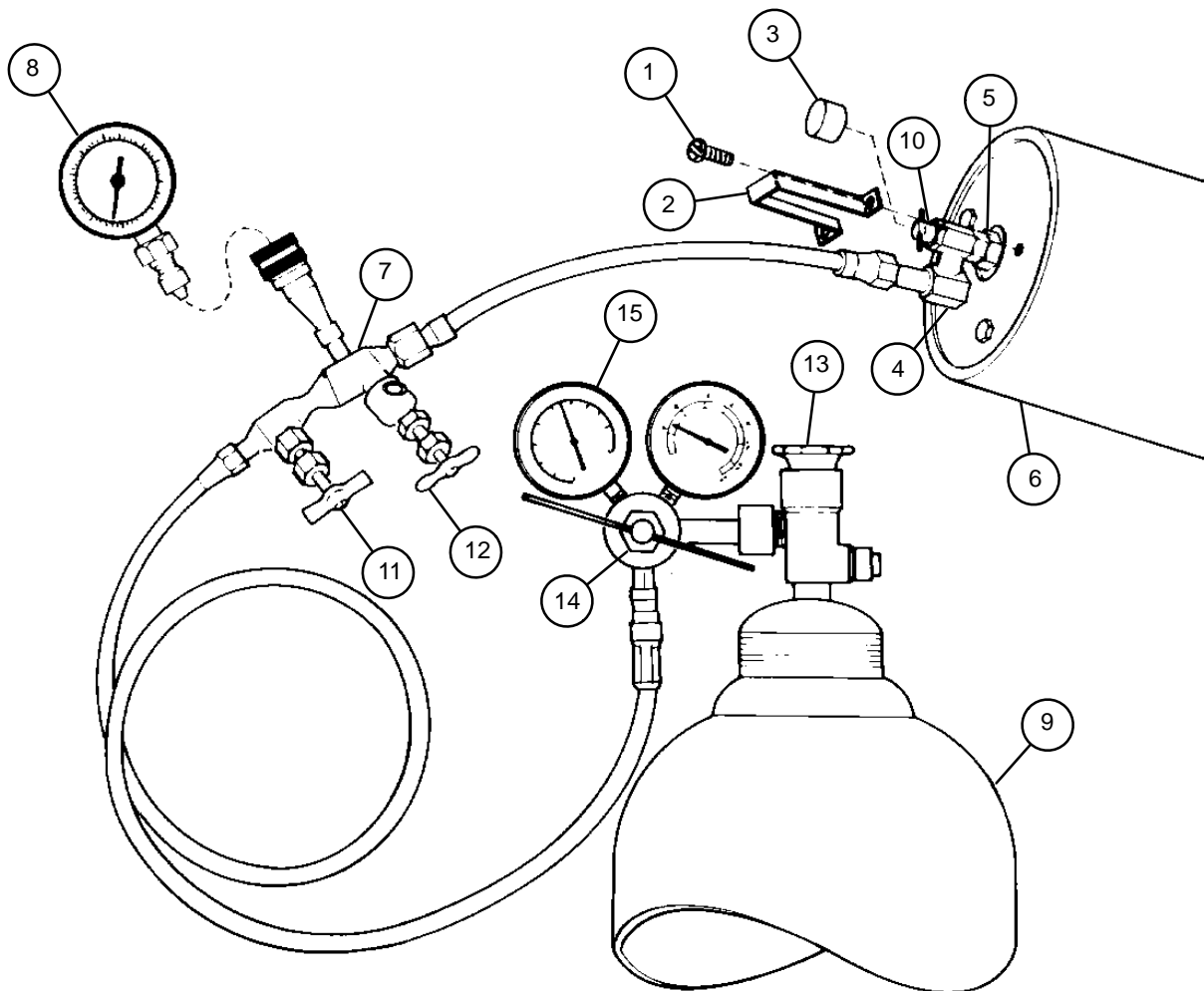
#### WARNING

Secondary accumulator assembly contains high pressure nitrogen. Use caution when handling and working with it.

- 4 Connect nitrogen charging assembly (7) to secondary accumulator assembly (6) and nitrogen charging cylinder (9).
- 5 Attach angle valve (10) of nitrogen charging assembly (7) to valve (5), but do not tighten angle valve (10). Close stop-check valve (11) and angle valve (12).
- 6 Open shutoff valve (13) on nitrogen cylinder (9).
- 7 Slowly open pressure regulator valve (14) until 3000 psi gage (15) shows 15-20 psi (103-138 kPa). Close pressure regulator valve.
- 8 Open stop-check valve (11) on nitrogen charging assembly (7). Tighten angle valve (10) just before 3000 psi gage (15) register 0 psi (0 kPa).
- 9 Loosen check valve nut (4) approximately one turn (2-1/4 turns is fully open).
- 10 Open pressure regulator valve (14) until 3000 psi gage (15) registers 1500 ± 50 psi (10342 ± 345 kPa).
- 11 Tighten check valve nut (4) when sound of nitrogen flow has stopped.
- 12 Close pressure regulator valve (14).



- 13 Slowly open angle valve (12) to release pressure in nitrogen charging assembly (7). Remove angle valve (10) from valve (5).
- 14 Install air valve cap (3) on valve (5).
- 15 Close shutoff valve (13) on nitrogen cylinder (9).
- 16 Remove nitrogen charging assembly (7) from nitrogen cylinder (9) and secondary accumulator assembly (6).
- 17 Install gage (8) on nitrogen charging assembly (7).
- 18 Install retaining strap (2) and two cap screws (1).



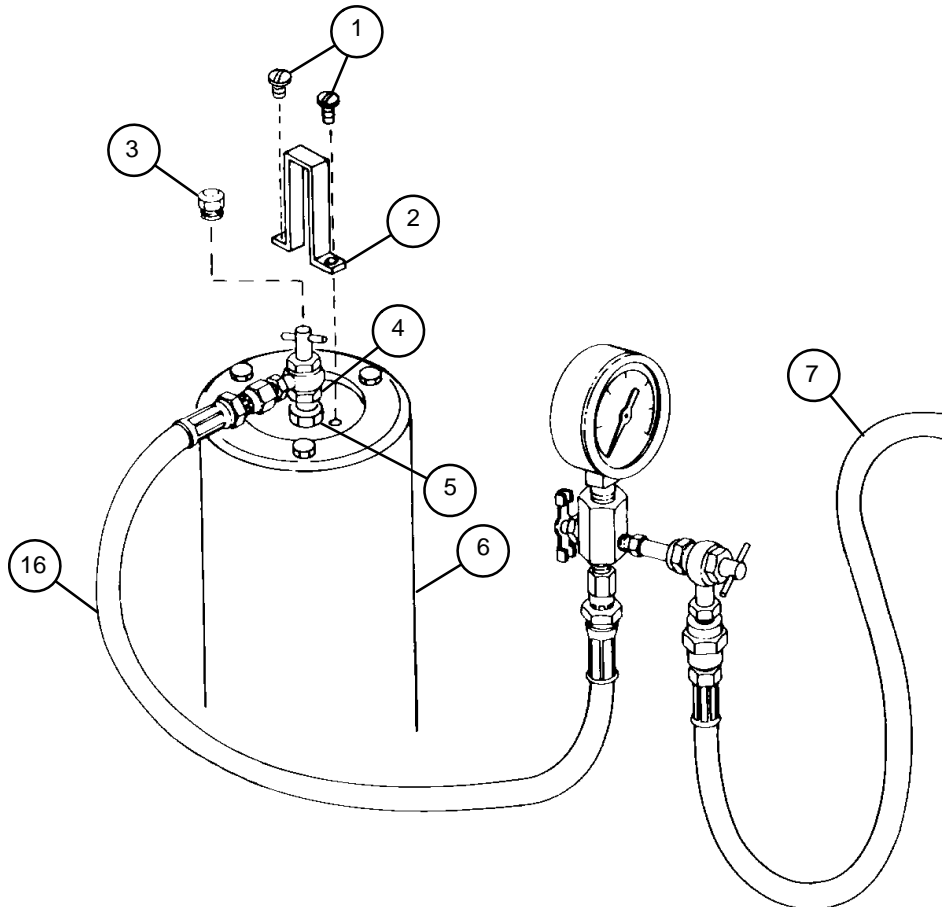
## 19-6 ACCUMULATOR ASSEMBLY, SECONDARY — CONTINUED

### b. Service (Method Two)

**WARNING**

Be sure nitrogen cylinder contains only dry nitrogen. Certain other gases will cause nitrogen cylinder or secondary accumulator assembly to explode resulting in possible injury.

- 1 Remove two cap screws (1) and retaining strap (2).
- 2 Remove air valve cap (3) and loosen check valve nut (4) on valve (5) to release nitrogen precharge pressure from secondary accumulator assembly (6).
- 3 Open and close nitrogen cylinder (9) shutoff valve (13) to clear shutoff valve seat of any dust or dirt.
- 4 Connect and tighten nitrogen charging assembly (7) to nitrogen cylinder (9), as shown. Repeat operation to clear nitrogen charging assembly hose.
- 5 Connect air pressure gage assembly (16) to valve (5) on secondary accumulator assembly (6).

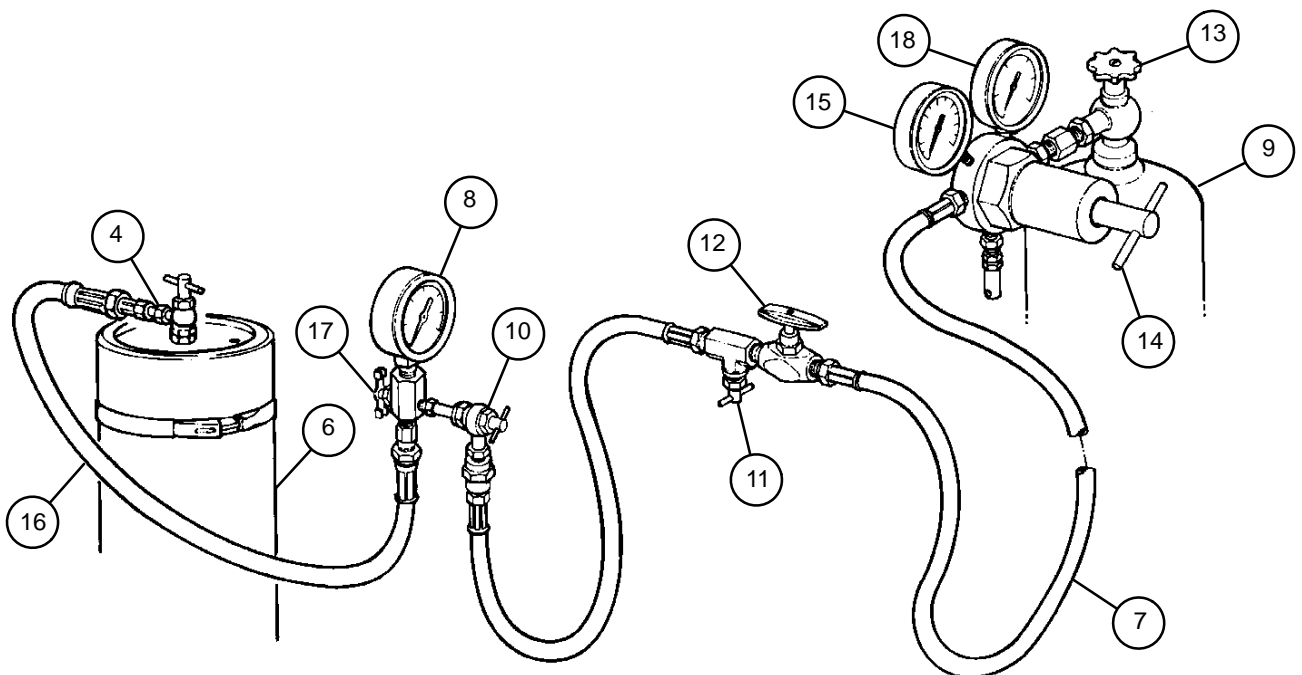


- 6 Connect nitrogen charging assembly (7) to air pressure gage assembly (16).
- 7 Open angle valve (10).
- 8 Close stop-check valve (11).
- 9 Close safety-relief valve (17).
- 10 Open valve (5) on secondary accumulator assembly (6) by turning check valve nut (4) counterclockwise.
- 11 Turn pressure regulator valve (14) counterclockwise until no spring pressure is felt.
- 12 Open shutoff valve (13) slowly until full cylinder pressure is indicated on 4000 psi gage (18) of pressure regulator valve (14).
- 13 Open pressure regulator valve (14) slowly, turning clockwise until pressure on 3000 psi gage (15) reads 50 psi (345 kPa).
- 14 Open angle valve (12), allowing dry nitrogen to enter secondary accumulator assembly (6) until gage (8) on air pressure gage assembly (16) reads 50 psi (345 kPa). Close angle valve.
- 15 Open safety-relief valve (17) until all dry nitrogen is bled from secondary accumulator assembly (6). Close safety-relief valve.
- 16 Repeat steps 13 and 14 to remove all traces of moisture prior to charging system to full pressure with dry nitrogen.

**CAUTION**

Charging system too fast will heat dry nitrogen. This will give inaccurate reading because pressure will decrease when nitrogen cools.

- 17 Open pressure regulator valve (14) slowly turning clockwise until pressure on 3000 psi gage (15) reads  $1500 \pm 50$  psi ( $10342 \pm 345$  kPa) at 70°F (21°C).



---

**19–6 ACCUMULATOR ASSEMBLY (SECONDARY) — CONTINUED**

---

**b. Service (Method Two) — Continued****NOTE**

Estimated time required to charge system is 30 minutes or more. System should be charged at ambient temperature of weapon.

- 18 Open angle valve (12) slowly, allowing dry nitrogen to charge system. Raise pressure in 100 psi (690 kPa) increments until gage (8) on air pressure gage assembly (16) stabilizes at  $1500 \pm 50$  psi ( $10342 \pm 345$  kPa) at 70°F (21°C).

**WARNING**

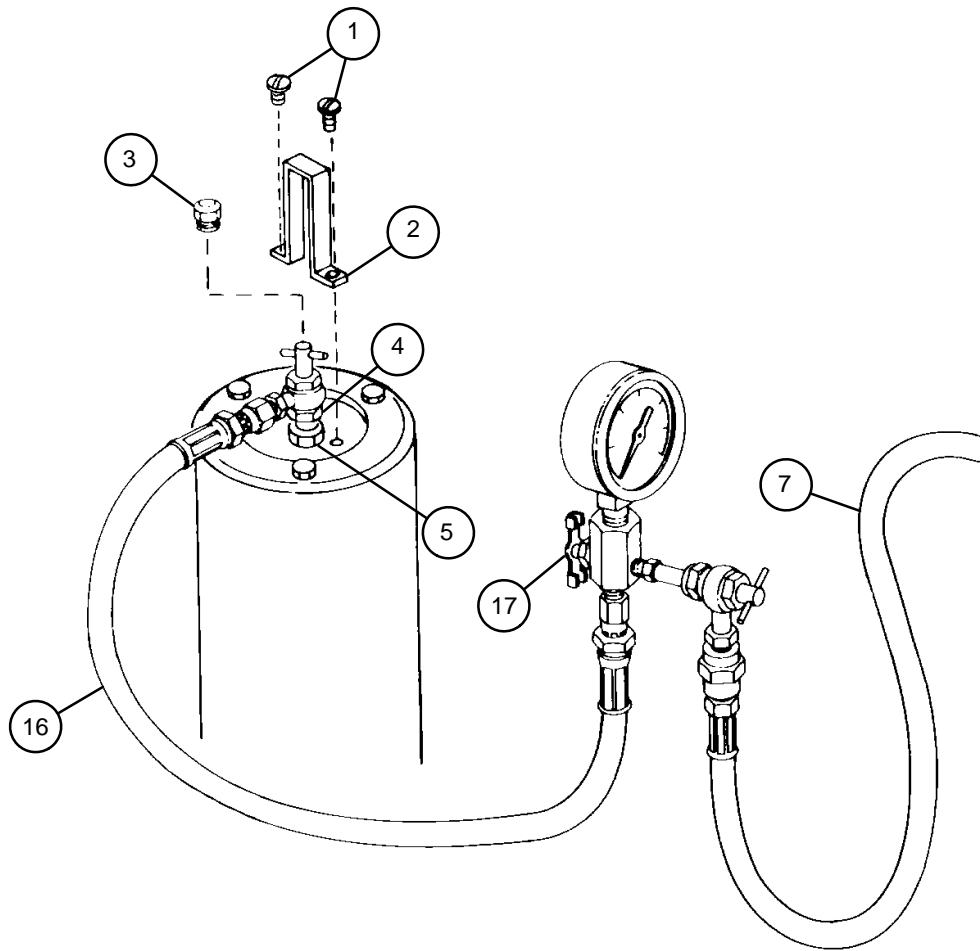
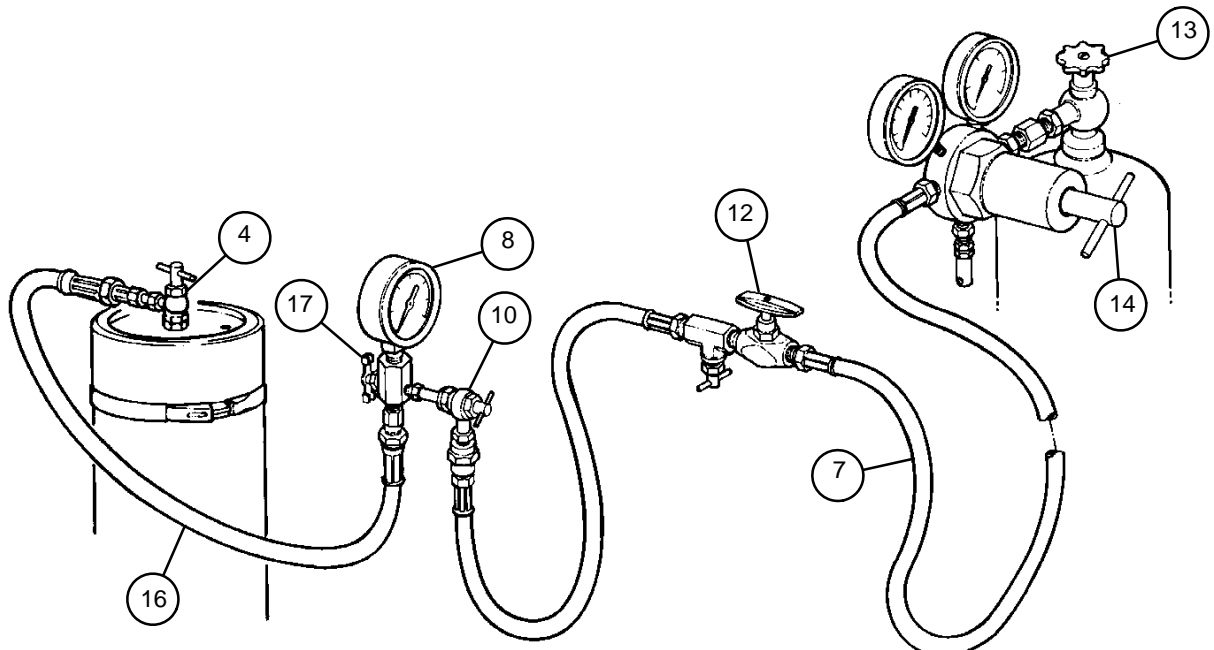
Failure to close check valve nut on secondary accumulator assembly could result in injury to personnel from high pressure gas.

- 19 Close check valve nut (4) and shutoff valve (13). Let system remain idle for at least one hour after charging.

**WARNING**

Failure to open safety-relief valve could result in injury from high pressure trapped in hoses.

- 20 Open safety-relief valve (17) to bleed pressure from nitrogen charging assembly (7) and air pressure gage assembly (16).
- 21 Disconnect nitrogen charging assembly (7) and air pressure gage assembly (16) at angle valve (10).
- 22 Close pressure regulator valve (14) by turning counterclockwise.
- 23 Disconnect nitrogen charging assembly (7) from shutoff valve (13).
- 24 Close safety-relief valve (17).
- 25 Open check valve nut (4).
- 26 Slowly open safety-relief valve (17), reducing pressure to 1500 psi (10342 kPa). Close safety-relief valve.
- 27 Close check valve nut (4) by turning clockwise.
- 28 Open safety-relief valve (17).
- 29 Disconnect air pressure gage assembly (16) from valve (5).
- 30 Install air valve cap (3) on valve (5).
- 31 Install two cap screws (1) and retaining strap (2).





## APPENDIX A REFERENCES

### GENERAL

This appendix lists all pamphlets, forms, manuals, bulletins, regulations, tables, and other references found in this manual. Appropriate indexes should be consulted frequently for latest applicable changes, revisions, and additions.

<u>CONTENTS</u>	<u>Page</u>
A-1 PAMPHLETS .....	A-1
A-2 FORMS .....	A-1
A-3 MANUALS .....	A-2
A-4 BULLETINS .....	A-3
A-5 REGULATIONS .....	A-4
A-6 SUPPLY CATALOGS .....	A-4
A-7 TABLES .....	A-5
A-8 HANDBOOKS .....	A-5
A-9 OTHER .....	A-5

### A-1 PAMPHLETS

Consolidated Index of Publications and Blank Forms	DA PAM 25-30
Army Maintenance Management System (TAMMS) User's Manual	DA PAM 750-8
Functional Users Manual for the Army Maintenance Management System - Aviation (TAMMS-A)	DA PAM 738-751

### A-2 FORMS

Accident Report	DA Form 285
Recommended Changes to Publications	DA Form 2028
Equipment Inspection and Maintenance Worksheet	DA Form 2404
Maintenance Request	DA Form 2407
Oil Analysis Log	DA Form 2408-20
Preventive Maintenance Schedule and Record	DD Form 314
Processing and Deprocessing Record for Shipment, Storage, and Issue of Vehicles and Spare Engines	DD Form 1397

---

## A-2 FORMS - CONTINUED

---

Equipment Utilization Record	DD Form 1970
Report of Discrepancy	SF 364
Product Quality Deficiency Report	SF 368

---

## A-3 MANUALS

---

■ First Aid for Soldiers	FM 4-25.11
■ NBC Contamination Avoidance	FM 3-3 (Superceded by FM 3-11.3)
■ NBC Protection	FM 3-4 (Superceded by FM 3-11.4)
■ NBC Decontamination	FM 3-5 (Superceded by FM 3-11.5)
Operation and Maintenance of Ordnance Materiel in Cold Weather (0 Degrees F to Minus 65 Degrees F)	FM 9-207
Howitzer, Light, Self-Propelled: 105MM, M108; and Howitzer, Medium, Self-Propelled: 155MM, M109, M109A1, M109A1B, M109A2; Processing for Storage and Shipment of	MIL-H-46709
Storage, Shipment, Handling, and Disposal of Chemical Agents and Hazardous Chemicals	TM 3-250
Operator's Manual for Tester, Airflow, Gas-Particulate Filter Unit: M39	TM 3-6680-316-10
Quadrant, Fire Control Gunner's: M1A1/M1A2	TM 9-1290-200-14&P
■ Ammunition and Explosives Standards	TM 9-1300-206 (Rescinded without replacement)
Inspection and Care of Bearings	TM 9-214
■ Operator's Manual: Welding Theory and Application	TM 9-237 (Superceded by TC 9-237)
Operator's Manual: Howitzer, Medium, Self-Propelled: 155MM, M109A2/M109A3/ M109A4/M109A5	TM 9-2350-311-10
Unit Maintenance Manual for Hull, Powerplant, Drive Controls, Tracks, Suspension and Associated Components, Howitzer, Medium, Self-Propelled: 155MM, M109A2/M109A3/M109A4/M109A5	TM 9-2350-311-20-1



Organizational, Direct Support and General Support Maintenance Repair Parts and Special Tools List: Hull, Powerplant, Drive Controls, Tracks, Suspension and Associated Components, Howitzer, Medium, Self-Propelled: 155MM M109A2 (NSN 2350-01-031-0586) (EIC:3EZ), M109A3 (NSN 2350-01-031-8851) (EIC:3E2), M109A4 (NSN 2350-01-277-5771) (EIC:3E8), M109A5 (NSN 2350-01-281-1719) (EIC:3E7)	TM 9-2350-311-24P-1
Organizational, Direct Support and General Support Maintenance Repair Parts and Special Tools List (Including Depot Maintenance Repair Parts and Special Tools) for Cab, Armament, Sighting And Fire Control, Elevating and Traversing Systems, and Associated Components Howitzer, Medium, Self-Propelled: 155MM M109A2 (NSN 2350-01-031-0586), M109A3 (NSN 2350-01-031-8851), M109A4 (NSN 2350-01-277-5771), M109A5 (NSN 2350-01-281-1719)	TM 9-2350-311-24P-2
General Maintenance Procedures for Fire Control Materiel	TM 9-254
Operator's, Unit, Intermediate Direct Support and Intermediate General Support Maintenance Manual for Lead-Acid Storage Batteries	TM 9-6140-200-14
Chemical, Toxicological, and Missile Fuel Handler's Protective Clothing	TM 10-277 (Rescinded without replacement) ■
Organizational and Direct Support Maintenance Manual for Radio Set, AN/PRC-68	TM 11-5820-882-23
Operator's and Organizational Maintenance Manual Including Repair Parts and Special Tools Lists: Intercommunication Set AN/VIC-1	TM 11-5830-340-12
Operator's and Organizational Maintenance Manual for Computer Groups, Gun Direction, OL-200/GYK-29(V) (P/O Computer System, Gun Direction, AN/GYK-29 (V))	TM 11-7440-283-12-1 (Rescinded without replacement) ■
Procedure for Destruction of Improved Conventional Munitions (ICM) to Prevent Enemy Use	TM 43-0002-33
Painting Instructions for Army Material	TM 43-0139
Storage and Materials Handling	TM 743-200 (Rescinded without replacement) ■
General Procedures for Purging and Charging of Fire Control Instruments	TM 750-116
Procedures for Destruction of Tank Automotive Equipment to Prevent Enemy Use	TM 750-244-6

#### A-4 BULLETINS

Solder and Soldering	TB SIG 222
Exercising of Recoil Mechanism and Equilibrators	TB 9-1000-234-13

---

## A-5 REGULATIONS

---

Notices, Instructions, and Report to Workers	10 CFR Part 19
Standards for Protection Against Radiation	10 CFR Part 20
Reporting of Defects and Noncompliance	10 CFR Part 21
Defense Traffic Management Regulation	AR 55-355 (Rescinded without replacement)
Research Development, Test and Evaluation of Materiel for Extreme Climatic Conditions	AR 70-38
Malfunctions Involving Ammunition and Explosives	AR 75-1
Army Physical Security Program	AR 190-13
Security of Army Property on Unit and Inspection Level	AR 190-15 (Rescinded without replacement)
Unit Status Reporting	AR 220-1
Accident Reporting and Records	AR 385-40
Army Logistics Readiness and Sustainability	AR 700-138
Reporting of Quality Deficiency Data	AR 702-7
Supply Policy Below the Wholesale Level	AR 710-2
Asset Transaction Reporting System	AR 710-3
Army Materiel Maintenance Concepts and Policies	AR 750-1

---

## A-6 SUPPLY CATALOGS

---

Consolidated Publication of Component Lists	SC 9999-01-SKO
Tool Kit, Artillery and Turret Mechanic's: Ordnance	CL 5180-95-A12*
Set, Kits, and Outfits Components List for Shop Equipment, Automotive Maintenance and Repair: Organizational Maintenance, Common No. 2, Less Power (NSN 4910-00-754-0650) (LIN W32730) and Shop Equipment, A	CL 4910-95-A72*

\*Contained in SC 9999-01-SKO, Consolidated Publication of Component Lists (EM0074)

---

**A-7 TABLES**


---

Modified Table of Organization and Equipment (MTOE)	CTA 8-100
Modified Table of Organization and Equipment (MTOE)	CTA 50-970

---

**A-8 HANDBOOKS**


---

Lubricants, Power Transmission Fluids, Corrosion Preservatives for Use in Ground Equipment Systems	MIL-HDBK-113
Guide for the Selection of Lubricants and Hydraulic Fluids for the Use in Shipboard Equipment	MIL-HDBK-267
Guide for the Selection of Lubricants, Fuels, and Compounds for the Use in Flight Vehicles and Components for Protection of Electrical and Electronic Parts	MIL-HDBK-275

---

**A-9 OTHER**


---

NCR License, License Conditions and License Application	
Rules Governing the Loading of Department of Defense Materiel on Open-Top Cars	Association of American Railroads Pamphlet, Section No. 6



## APPENDIX B MAINTENANCE ALLOCATION CHART (MAC)

### SECTION I. Introduction

---

#### B-1 THE ARMY MAINTENANCE SYSTEM MAC

---

- a. This introduction (Section I) provides a general explanation of all maintenance and repair functions authorized at two maintenance levels under the two level Army Maintenance System concept.
  - b. The Maintenance Allocation Chart (MAC) in Section II designates overall authority and responsibility for the performance of maintenance functions on the identified end item or component. The application of the maintenance functions to the end item or component will be consistent with the capacities and capabilities of the designated maintenance levels, which are shown in the MAC in column (4) as:
    - Field** - includes two subcolumns, unit and direct support maintenance.
    - Unit** - includes two subcolumns, C (operator/crew) and O (unit) maintenance.
    - Direct Support** - includes an F subcolumn.
    - Sustainment** - includes two subcolumns, general support and depot maintenance.
    - General Support** - includes an H subcolumn.
    - Depot** - includes a D subcolumn.
  - c. Section III lists the tools and test equipment (both special tools and common tool sets) required for each maintenance function as referenced from Section II.
  - d. Section IV contains supplemental instructions and explanatory notes for a particular maintenance function.
- 

#### B-2 MAINTENANCE FUNCTIONS

---

Maintenance functions are limited to and defined as follows:

- a. **Inspect.** To determine the serviceability of an item by comparing its physical, mechanical, and/or electrical characteristics with established standards through examination (e.g. by sight, sound, or feel).
- b. **Test.** To verify serviceability by measuring the mechanical, pneumatic, hydraulic, or electrical characteristics of an item and comparing those characteristics with prescribed standards.
- c. **Service.** Operations required periodically to keep an item in proper operating condition, e.g., to clean (includes decontaminate, when required), to preserve, to drain, to paint, or to replenish fuel, lubricants, chemical fluids, or gases.
- d. **Adjust.** To maintain or regulate, within prescribed limits, by bringing into proper position, or by setting the operating characteristics to specified parameters.
- e. **Align.** To adjust specified variable elements of an item to bring about optimum or desired performance.
- f. **Calibrate.** To determine and cause corrections to be made or to be adjusted on instruments or test, measuring, and diagnostic equipment used in precision measurement. Consists of comparisons of two instruments, one of which is a certified standard of known accuracy, to detect and adjust any discrepancy in the accuracy of the instrument being compared.

---

## B-2 MAINTENANCE FUNCTIONS - CONTINUED

---

- g. Remove/Install. To remove and install the same item when required to perform service or other maintenance functions. Install may be the act of emplacing, seating, or fixing into position a spare, repair part, or module (component or assembly) in a manner to allow the proper functioning of an equipment or system.
- h. Replace. To remove an unserviceable item and install a serviceable counterpart in its place. "Replace" is authorized by the MAC and assigned maintenance level is shown as the 3d position code of the SMR code.
- i. Repair. The application of maintenance services<sup>1</sup> including fault location/troubleshooting<sup>2</sup>, removal/installation and disassembly/assembly procedures, and maintenance actions<sup>4</sup> to identify troubles and restore serviceability to an item by correcting specific damage, fault, malfunction, or failure in a part, subassembly, module (component or assembly), end item, or system.
- j. Overhaul. That maintenance effort (service/action) prescribed to restore an item to a completely serviceable/operational condition as required by maintenance standards in appropriate technical manuals (i.e., DMWR). Overhaul is normally the highest degree of maintenance performed by the Army. Overhaul does not normally return an item to like new condition.
- k. Rebuild. Consists of those services/actions necessary for the restoration of unserviceable equipment to a like new condition in accordance with original manufacturing standards. Rebuild is the highest degree of materiel maintenance applied to Army equipment. The rebuild operation includes the act of returning to zero those age measurements (e.g., hours/miles) considered in classifying Army equipment/components.

---

## B-3 EXPLANATION OF COLUMNS IN THE MAC, SECTION II.

---

- a. Column 1, Group Number. Column 1 lists functional group code numbers, the purpose of which is to identify maintenance significant components, assemblies, subassemblies, and modules with the next higher assembly.
- b. Column 2, Component/Assembly. Column 2 contains the item names of components, assemblies, subassemblies, and modules for which maintenance is authorized. (\* indicates item applies only to M109A2/M109A3 howitzers.) (\*\* indicates item applies only to M109A4/M109A5 howitzers.) No asterisk indicates item is common to all vehicle configurations.
- c. Column 3, Maintenance Function. Column 3 lists the functions to be performed on the item listed in Column 2. (For detailed explanation of these functions, see paragraph B-2.)

<sup>1</sup> Services - Inspect, test, service, adjust, align, calibrate, and/or replace.

<sup>2</sup> Fault location/troubleshooting - The process of investigating and detecting the cause of equipment malfunctioning; the act of isolating a fault within a system or unit under test (UUT).

<sup>3</sup> Disassembly/assembly - The step-by-step breakdown (taking apart) of a spare/functional group coded item to the level of its least component, that is assigned an SMR code for the level of maintenance under consideration (i.e., identified as maintenance significant).

<sup>4</sup> Actions - Welding, grinding, riveting, straightening, facing, machining, and/or resurfacing.

- d. Column 4, Maintenance Level. Column 4 specifies each level of maintenance authorized to perform each function listed in Column 3, by indicating work-time required each expressed as man-hours in whole hours or decimals in the appropriate subcolumn. This work-time figure represents the active time required to perform that maintenance function at the indicated level of maintenance. If the number or complexity of the tasks within the listed maintenance function vary at different maintenance levels, appropriate work-time figures are to be shown for each level. The work-time figure represents the average time required to restore an item (assembly, subassembly, component, module, end item, or system) to a serviceable condition under typical field operating conditions. This time includes preparation time (including any necessary disassembly/assembly time), troubleshooting/fault location time, and quality assurance time in addition to the time required to perform the specific tasks identified for the maintenance functions authorized in the maintenance allocation chart. The symbol designations for the various maintenance levels are as follows:

Field:

- C . . . . . Operator or crew maintenance
- O . . . . . Unit maintenance
- F . . . . . Direct support maintenance

Sustainment:

- L . . . . . Specialized Repair Activity (SRA)<sup>5</sup>
- H . . . . . General support maintenance
- D . . . . . Depot maintenance (\*\*indicates time at depot maintenance)

- e. Column 5, Tools and Test Equipment reference code. Column 5 specifies, by code, those common tool sets (not individual tools), common TMDE, and special tools, special TMDE, and special support equipment required to perform the designated function. Codes are keyed to tools and test equipment in Section III.
- f. Column 6, Remarks. When applicable, this column contains a letter code, in alphabetical order, which is keyed to the remarks contained in Section IV.

**B-4 EXPLANATION OF COLUMNS IN TOOL AND TEST EQUIPMENT REQUIREMENTS, SECTION III.**

- a. Column 1, Reference Code. The tool and test equipment reference code correlates with a code used in the MAC, Section II, Column 5.
- b. Column 2, Maintenance Level. The lowest level of maintenance authorized to use the tool or test equipment.
- c. Column 3, Nomenclature. Name or identification of the tool or test equipment.
- d. Column 4, National Stock Number. The National Stock Number of the tool or test equipment.
- e. Column 5, Tool Number. The manufacturer's part number, model number, or type number.

**B-5 EXPLANATION OF COLUMNS IN REMARKS, SECTION IV.**

- a. Column 1, Remarks Code. The code recorded in column 6, Section II.
- b. Column 2, Remarks. This column lists information pertinent to the maintenance function being performed as indicated in the MAC, Section II.

<sup>5</sup> This maintenance level is not included in Section II, column (4) of the Maintenance Allocation Chart. Functions to this level of maintenance are identified by a work-time figure in the "H" column of Section II, column (4), and an associated reference code is used in the Remarks column (6). This code is keyed to Section IV, Remarks, and the SRA complete repair application is explained there.

**SECTION II. MAINTENANCE ALLOCATION CHART - Cab Armament, Sighting and Fire Control, Elevating And Traversing Systems And Associated Components.**

(1)  GROUP NUMBER	(2)  COMPONENT/ ASSEMBLY	(3)  MAINTENANCE FUNCTION	(4) MAINTENANCE LEVEL					(5) TOOLS AND EQUIPMENT REF CODE	(6) REMARKS CODE	
			FIELD		SUSTAINMENT					
			UNIT		DS	GS	DEPOT			
			C	O	F	H	D			
00	CAB ASSEMBLY	REMOVE			4.0			1-5		
		INSTALL			4.0			1-5		
01	BEARING ASSEMBLY	INSPECT		0.5						
		SERVICE	0.5							
		REPLACE			6.0		**	1-5		
		REPAIR				8.0	**	1-5		
		OVERHAUL								
0101	RACE RING ASSEMBLY	INSPECT	0.5					4		
		SERVICE		0.5				4		
		REPAIR				0.5	**	4		
02	MOUNT AND HOWITZER ASSEMBLY									
0201	CANNON ASSEMBLY, HOWITZER M185/M284	INSPECT	0.2							
		SERVICE	2.0							
		REPLACE			6.0			3-7		
		REPAIR				8.0		3-7		
		OVERHAUL					**			
020101	COLLAR, THRUST	REPAIR		1.0				4, 8		
		REPLACE		1.0				4		
020102	TUBE ASSEMBLY	REPLACE			1.0			4-7		
02010201	EVACUATOR ASSEMBLY	REPAIR		0.5				4, 8		
		REPLACE		0.5				4		
020103	FIRING MECHANISM ASSEMBLY	REM/INS	0.1					4		
		INSPECT	0.2					4		
		REPLACE		0.1				4		
		REPAIR		0.5				4		
020104	BREECH MECHANISM	INSPECT		0.2				4		
		REPAIR		1.0	6.0			3, 4		
02010401	BLOCK ASSEMBLY (FIRING)	REM/INS	0.5			4				
		REPLACE		0.5				4		
		REPAIR		0.5				4		
0201040101	FOLLOWER ASSEMBLY	REM/INS	0.2							
		REPLACE		0.2				4		
		REPAIR		0.5				4		
02010402	SPINDLEASSEMBLY	REM/INS	0.5							
		REPLACE		1.0				4		
		REPAIR		1.0						





**SECTION II. MAINTENANCE ALLOCATION CHART - Cab Armament, Sighting and Fire Control, Elevating And Traversing Systems And Associated Components. - Continued**

(1)  GROUP NUMBER	(2)  COMPONENT/ ASSEMBLY	(3)  MAINTENANCE FUNCTION	(4) MAINTENANCE LEVEL					(5) TOOLS AND EQUIPMENT REF CODE	(6) REMARKS CODE
			FIELD		SUSTAINMENT				
			UNIT		DS	GS	DEPOT		
			C	O	F	H	D		
0202010402	VARIABLE RECOIL ASSEMBLY	SERVICE INSPECT REPAIR	0.4 0.5				8.0		4 3-6
020201040204	BUFFER ASSEMBLY	INSPECT REPLACE REPAIR		0.5		2.0	3.0		4, 9 3, 4 3, 4
020201040205	ACTUATOR ASSEMBLY	REPLACE REPAIR			4.0		4.0		4-6 3-6
020201040206	CRADLE ASSEMBLY	REPLACE REPAIR						** **	
020202	ACCUMULATOR ASSEMBLY (REPLENISHER)	SERVICE REPLACE REPAIR	0.5	0.2 1.5 0.2			2.0		10 4, 9 4, 9
03 0301	CAB HYDRAULICS GAGE ASSEMBLY	REPLACE REPAIR		0.5 0.5					4, 6 4, 6
0302	POWER PACK ASSEMBLY	TEST SERVICE REPLACE REPAIR	0.2	0.5 0.5		3.0	3.0		4, 11, 12 4, 13 4, 13
030202	MOTOR ASSEMBLY	REPLACE REPAIR					3.5	**	4, 13
030203	COVER ASSEMBLY	REPLACE REPAIR					2.0 2.5		4 4
030204	FILTER ASSEMBLY*	SERVICE REPLACE REPAIR					2.0 3.0 3.5		4, 13 4, 13 4, 13
030204	BODY ASSEMBLY***	SERVICE REPLACE REPAIR					2.0 3.0 3.5		
0303	BY-PASS VALVE ASSEMBLY	REPLACE REPAIR		0.5			0.5		4, 6 4, 6
030301	BODY ASSEMBLY	REPLACE REPAIR					0.5 0.5		4 4

**SECTION II. MAINTENANCE ALLOCATION CHART - Cab Armament, Sighting and Fire Control, Elevating And Traversing Systems And Associated Components. - Continued**

(1)  GROUP NUMBER	(2)  COMPONENT/ ASSEMBLY	(3)  MAINTENANCE FUNCTION	(4) MAINTENANCE LEVEL					(5)  TOOLS AND EQUIPMENT REF CODE	(6)  REMARKS CODE	
			FIELD		SUSTAINMENT					
			UNIT		DS	GS	DEPOT			
			C	O	F	H	D			
0304	ACCUMULATOR ASSEMBLY (MANUAL PUMP)	TEST		0.7				4, 11		
		SERVICE		0.5				4, 14		
		REPLACE		0.5				4, 6, 14		
		REPAIR				1.0		3, 4, 6, 14		
0305	ACCUMULATOR ASSEMBLY (MAIN)	TEST	0.2	0.3	0.5			4, 14, 15		
		SERVICE		0.5				4, 14, 15		
		REPLACE			2.0			4, 14, 15		
		REPAIR				3.0		4, 14, 15		
0306	ACCUMULATOR ASSEMBLY (PRIMARY)	SERVICE		0.7				4, 14		
		REPLACE		0.5				4, 14		
		REPAIR				2.0		4, 14		
		TEST		0.3	0.5			4, 14		
0307	ACCUMULATOR ASSEMBLY (SECONDARY)	SERVICE		0.7				4, 14		
		REPLACE		0.5				4, 14		
		REPAIR				2.0		4, 14		
		TEST		0.3	0.5			4, 14		
0308	EQUILIBRATION MANIFOLD ASSEMBLY	REPLACE		1.0				3, 4		
		REPAIR				1.0	1.0	3, 4		
		ADJUST				1.5	1.5	3, 4		
0309	EQUILIBRATION HAND PUMP	REPLACE		0.8				4, 6		
		REPAIR		1.0				4, 6		
0310	MECHANISM ASSEMBLY, ELEVATION EQUILIBRATOR	REPLACE			6.0			3, 4, 6		
		REPAIR				8.0		3, 4, 6		
		ADJUST	0.5	0.5				3, 4, 6		
		SERVICE OVERHAUL		0.7				4	**	
031004	VALVE ASSEMBLY (SAFETY)	REPLACE			1.0			4, 6		
		REPAIR				1.5		4, 6		
0311	VALVE ASSEMBLY, SELECTOR	REPLACE		1.0				4		
		REPAIR				0.5		4		
0312	CONTROL ASSEMBLY	REPLACE		1.0				4		
		REPAIR				3.0		4		
031201	VALVE, SHUTTLE ASSEMBLY	REPLACE				0.4		4		
		REPAIR				0.8		4		
031202	PUMP ASSEMBLY	REPLACE				1.2		4		
		REPAIR				0.7		3, 4		

**SECTION II. MAINTENANCE ALLOCATION CHART - Cab Armament, Sighting and Fire Control, Elevating And Traversing Systems And Associated Components. - Continued**

(1)  GROUP NUMBER	(2)  COMPONENT/ ASSEMBLY	(3)  MAINTENANCE FUNCTION	(4) MAINTENANCE LEVEL					(5) TOOLS AND EQUIPMENT REF CODE	(6) REMARKS CODE
			FIELD		SUSTAINMENT				
			UNIT		DS	GS	DEPOT		
			C	O	F	H	D		
03120201	PUMP, AXIAL	REPLACE			0.5	0.5		4	
		REPAIR			4.0	4.0		3, 4	
03120202	HANDLE ASSEMBLY	REPLACE				0.2		4	
		REPAIR				0.7		4	
031203	CONTROL ASSEMBLY (RIGHT AND LEFT)	REPLACE		0.8				4	
		REPAIR				4.5		4	
03120301	HANDLE ASSEMBLY	REPLACE		0.5				4	
		REPAIR		0.5				4	
03120302	HOUSING CAM CONTROL	REPLACE				1.0		4	
		REPAIR			0.2	0.2		4	
03120304	HARNES, HANDLE	REPLACE			0.5			4	
		REPAIR				0.5		4	
0313	FILTER ASSEMBLY***	INSPECT		0.2				4	
		REPLACE		1.0				4, 11	
		REPAIR		0.5				4, 11	
04	RAMMER SYSTEM	INSPECT	0.3	0.3				4	
		SERVICE	0.1						
0401	RAMMER ASSEMBLY	INSPECT	0.3	0.3				4	
		ADJUST	0.3	0.5				4	
		REPLACE		3.0				4, 9	
		REPAIR		2.0	6.0	6.0		3, 4, 9	
040101	CYLINDER ASSEMBLY	REPLACE			2.0			4	
		REPAIR				4.0		3, 4	
0402	VALVE ASSEMBLY ACTUATING	SERVICE	0.1						
		REPLACE		1.0				4	
		REPAIR				1.5		4	
05	CAB ELECTRICAL (INSTALLATION)								
0501	ELECTRICAL LEADS AND HARNES ASSEMBLIES	TEST		1.5				4, 9, 11	
		REPLACE		3.0				4, 9, 11	
		REPAIR		5.0				4, 9, 11	
0502	DOME LIGHT ASSEMBLY	INSPECT	0.1						
		REPLACE		0.2				4	
		REPAIR	0.2	0.5				4	

**SECTION II. MAINTENANCE ALLOCATION CHART - Cab Armament, Sighting and Fire Control, Elevating And Traversing Systems And Associated Components. - Continued**

(1)  GROUP NUMBER	(2)  COMPONENT/ ASSEMBLY	(3)  MAINTENANCE FUNCTION	(4) MAINTENANCE LEVEL					(5)  TOOLS AND EQUIPMENT REF CODE	(6)  REMARKS CODE	
			FIELD		SUSTAINMENT					
			UNIT		DS	GS	DEPOT			
			C	O	F	H	D			
0503	BOX ASSEMBLY (GUNNERS)	INSPECT		0.5				4		
		TEST		0.3				4, 11		
		REPLACE		0.4				4, 11		
		REPAIR		0.7				4, 11		
0504	BOX ASSEMBLY, POWER RELAY	REPLACE		0.4				4		
		REPAIR		1.0				4		
06	CAB ELECTRICAL ARM ASSEMBLY									
0601	SEGMENT RING, CONTACT	INSPECT				0.5				
		TEST		0.2				4		
		REPLACE		0.5				4		
		REPAIR				2.0		3, 4, 6		
0602	ARM, ELECTRICAL	TEST		0.4				4, 9		
		REPLACE		0.5				4, 9		
		REPAIR		2.0				4, 9		
		ADJUST		1.0				4		
07	WEATHER COVER	SERVICE	0.1					4		
		REPLACE		1.5				4		
		REPAIR		2.0				4		
08	TURRET LOCK ASSEMBLY	SERVICE	0.1					4		
		REPLACE		1.0				4		
		REPAIR		1.7						
09	TRAVERSING MECHANISM ASSEMBLY	ADJUST				1.0		4, 16		
		SERVICE	0.5	1.0				4		
		REPAIR				6.0		3, 4, 17		
		REPLACE			2.0			3, 4, 18		
		OVERHAUL					**			
0901	PUMP ASSEMBLY	REPLACE				1.0		4		
		REPAIR					1.5	3, 4		
0902	HYDRAULIC MOTOR ASSEMBLY	REPLACE				2.0		4		
		REPAIR					4.0	3, 4		
09020101	RELIEF VALVE ASSEMBLY	REPLACE					1.0	3, 4		
		REPAIR					1.5	3, 4		
0903	BRUSH ASSEMBLY*	REPLACE		0.2				4		

**SECTION II. MAINTENANCE ALLOCATION CHART - Cab Armament, Sighting and Fire Control, Elevating And Traversing Systems And Associated Components. - Continued**

(1)  GROUP NUMBER	(2)  COMPONENT/ ASSEMBLY	(3)  MAINTENANCE FUNCTION	(4) MAINTENANCE LEVEL					(5) TOOLS AND EQUIPMENT REF CODE	(6) REMARKS CODE
			FIELD		SUSTAINMENT				
			UNIT		DS	GS	DEPOT		
			C	O	F	H	D		
0904	BEARING UNIT (NO-BAK)	REPLACE			1.0			4	
		REPAIR			1.0			3, 4	
0905	GEARSHAFT ASSEMBLY***	REPLACE			1.5			4	
		REPAIR			2.0			4	
10	COMMANDERS CUPOLA ASSEMBLY	SERVICE	0.1						
		REPLACE		2.0				4	
		REPAIR		4.5				4	
1001	SUPPORT ASSEMBLY	SERVICE	0.1						
		REPLACE		0.4				4	
		REPAIR		0.5				4	
100101	ARM, ADAPTER ASSEMBLY	REPLACE		0.2				4	
		REPAIR		0.2				4	
1003	CUPOLA RACE RING	REPLACE			2.0			4	
		REPAIR					3.0	3, 4	
11	COMMANDERS SEAT								
1101	SEAT ASSEMBLY	SERVICE	0.1						
		ADJUST		1.0				4	
		REPLACE		0.5				4	
		REPAIR		1.5				4	
110101	SEAT ASSEMBLY	REPLACE		0.5				4	
		REPAIR		0.5				4	
110102	ADJUSTER ASSEMBLY	REPLACE		0.5				4	
		REPAIR		1.0				4	
12	DOOR AND HATCH ASSEMBLIES								
1201	DOOR ASSEMBLY, GUNNER	SERVICE	0.1						
		REPLACE		0.5				4, 9	
		REPAIR		1.5				4, 9	
1202	DOORS, SIDE								

**SECTION II. MAINTENANCE ALLOCATION CHART - Cab Armament, Sighting and Fire Control, Elevating And Traversing Systems And Associated Components. - Continued**

(1)  GROUP NUMBER	(2)  COMPONENT/ ASSEMBLY	(3)  MAINTENANCE FUNCTION	(4) MAINTENANCE LEVEL					(5)  TOOLS AND EQUIPMENT REF CODE	(6)  REMARKS CODE		
			FIELD		SUSTAINMENT						
			UNIT		DS	GS	DEPOT				
			C	O	F	H	D				
120201	LATCH ASSEMBLY	SERVICE REPLACE REPAIR	0.2								
				0.2					4		
				0.5					4		
120202	BUMPER ASSEMBLY	REPLACE REPAIR		0.2					4		
				0.2					4		
120203	CAB SIDE DOORS, LEFT AND RIGHT	SERVICE REPLACE REPAIR	0.1								
				1.0					4		
				1.5					4		
1203	DOOR, BUSTLE	SERVICE	0.3								
120301	DOOR ASSEMBLY PROJECTILE	REPLACE REPAIR		0.2					4		
				0.5					4		
120302	DOOR ASSEMBLY, LEFT AND RIGHT, BUSTLE	REPLACE REPAIR		0.5					4		
				0.7					4		
12030301	CLEVIS ASSEMBLY, LEFT AND RIGHT	REPLACE REPAIR		0.5					4		
				0.5					4		
13	TRUNNION BRACKET	REPLACE REPAIR OVERHAUL				6.0			3,4		
								**			
								**			
14	CAB AMMO RACK										
1401	STOWAGE RACK ASSEMBLY	SERVICE REPLACE REPAIR	0.2				5.0		4		
				0.5	1.5				4		
140101	RETAINER ASSEMBLY	REPLACE REPAIR		0.2					4		
				0.4					4		
15	CAB STOWAGE										
1501	STOWAGE BOXES	SERVICE REPLACE REPAIR	0.1								
				1.0					4		
				0.5					4, 19		
16	BALLISTIC COVER ASSEMBLY	SERVICE REPLACE REPAIR	0.3	0.5			4.0		4		
				5.0					4		
									4		

**SECTION II. MAINTENANCE ALLOCATION CHART - Cab Armament, Sighting and Fire Control, Elevating And Traversing Systems And Associated Components. - Continued**

(1)  GROUP NUMBER	(2)  COMPONENT/ ASSEMBLY	(3)  MAINTENANCE FUNCTION	(4) MAINTENANCE LEVEL					(5)  TOOLS AND EQUIPMENT REF CODE	(6)  REMARKS CODE
			FIELD		SUSTAINMENT				
			UNIT		DS	GS	DEPOT		
			C	O	F	H	D		
17	NBC ***								
1701	HEATER, AIR, ELECTRICAL***	INSPECT REPLACE REPAIR		0.3 0.5 0.5				4 4	
1702	PURIFIER, AIR***	INSPECT REPLACE REPAIR TEST		0.3 0.6 0.5	1.0			4 4 10	
170201	PRECLEANER AIR PURIFIER***	INSPECT REPLACE REPAIR		0.5 1.5 2.5				4 4 4	
170202	FILTERS***	INSPECT SERVICE REPLACE		0.5 0.5 0.5				4 4	
1703	CONTROL BOX ASSEMBLY***	TEST REPLACE REPAIR		0.3 0.5 1.0				4 4	
18	SIGHTING EQUIPMENT								
1803	COLLIMATOR, INFINITY AIMING REFERENCE (M1A1)	INSPECT SERVICE REPLACE REPAIR	0.1	0.1 0.5 0.5 4.0	0.1	0.1		4, 20 4,10 4, 20-28	
180301	CASE, COLLIMATOR (M1A1)	INSPECT REPLACE REPAIR			0.1 0.1			20	
180302	COVER ASSEMBLY (M1A1)	INSPECT REPLACE REPAIR			0.1 0.5			20 20	
180303	MOUNT, TRIPOD COLLIMATOR INFINITY AIMING REF. (M1A1) 10556235	INSPECT REPLACE REPAIR			0.1 0.5			20 20,21	
18030301	LEG, COLLIMATOR	INSPECT REPLACE REPAIR			0.1 0.2			20 20	



**SECTION II. MAINTENANCE ALLOCATION CHART - Cab Armament, Sighting and Fire Control, Elevating And Traversing Systems And Associated Components. - Continued**

(1)  GROUP NUMBER	(2)  COMPONENT/ ASSEMBLY	(3)  MAINTENANCE FUNCTION	(4) MAINTENANCE LEVEL					(5)  TOOLS AND EQUIPMENT REF CODE	(6)  REMARKS CODE	
			FIELD		SUSTAINMENT					
			UNIT		DS	GS	DEPOT			
			C	O	F	H	D			
1803030101	TUBE ASSEMBLY METAL	INSPECT REPLACE			0.1		0.5		20	
1803030102	LEG SECTION, TRIPOD	INSPECT REPLACE			0.1		0.5		20	
18030302	YOKE, COLLIMATOR INFINITY AIMING REF. (M1A1)	INSPECT REPLACE REPAIR			0.1 0.5		2.0		20 20, 21	
180304	COLLIMATOR, SCOPE (M1A1)	INSPECT SERVICE REPLACE REPAIR		0.1	0.1 0.5	0.1	0.5 0.5 2.7		10 20, 21 20, 21, 22-28	
18030401	CELL ASSEMBLY	INSPECT REPLACE REPAIR					0.1 0.5 1.0		20, 26 20, 24	
18030402	CELL ASSEMBLY, OPTICAL (M1A1)	INSPECT REPLACE REPAIR					0.1 1.0 1.0		20, 22 20, 22	
1806	MOUNT, M146	INSPECT ADJUST REPLACE REPAIR OVERHAUL	0.1	0.1	0.1 1.0		** 10.0		4, 20, 21 20, 21 4 4, 20, 21 4, 20, 21, 29	
180601	BRACKET ASSEMBLY	INSPECT REPLACE REPAIR		0.1	0.5		0.5		4, 20 20	
180602	CABLE ASSEMBLY	INSPECT REPLACE REPAIR		0.1	0.1		1.0		4 4 20, 21	
1807	TELESCOPE, ELBOW M118A2/M118A3	INSPECT SERVICE REPLACE REPAIR OVERHAUL	0.1	0.1	0.1	0.2	** 23.5		4, 20, 21, 29 4, 10 4 4, 20, 21 20, 21, 29-32	
180701	EYEPIECE AND ERECTOR LENS SUB-ASSEMBLY	INSPECT ADJUST REPAIR					0.1 1.0 4.0	** ** **	20, 21 20, 21	
18070101	CELL ASSEMBLY	INSPECT REPAIR					0.1 2.0		20, 21	

**SECTION II. MAINTENANCE ALLOCATION CHART - Cab Armament, Sighting and Fire Control, Elevating And Traversing Systems And Associated Components. - Continued**

(1)  GROUP NUMBER	(2)  COMPONENT/ ASSEMBLY	(3)  MAINTENANCE FUNCTION	(4) MAINTENANCE LEVEL					(5)  TOOLS AND EQUIPMENT REF CODE	(6)  REMARKS CODE	
			FIELD		SUSTAINMENT					
			UNIT		DS	GS	DEPOT			
			C	O	F	H	D			
18070102	CELL ASSEMBLY	INSPECT				0.3	**	20, 21		
		REPAIR				0.1	**			
18070103	CELL ASSEMBLY	INSPECT				0.3	**	20, 21		
		REPAIR				1.0	**			
180702	TELESCOPE AND RETICLE CAGE ASSEMBLY	INSPECT			0.1	0.2	**	20		
		ADJUST				1.0	**			
		REPAIR				6.2	**			
18070201	CELL ASSEMBLY	INSPECT				0.3	**	20, 21		
		REPAIR				1.0	**			
18070202	WORMSHAFT ASSEMBLY	INSPECT				0.1		20, 21		
		REPAIR				1.0				
18070203	COVER ASSEMBLY	INSPECT				0.1		20		
		REPLACE				0.2				
		REPAIR				0.5				
18070204	WIRING HARNESS	INSPECT				0.1		20, 21		
		REPLACE				1.5				
		REPAIR				1.0				
18070205	LEVEL ASSEMBLY	INSPECT				0.2		20, 21		
		REPLACE				0.5				
		REPAIR				1.5				
		ADJUST				0.5				
18070206	RETICLE CAGE ASSEMBLY	INSPECT				0.1	**	20, 34		
		ADJUST				1.0	**			
		REPLACE				1.0	**			
		REPAIR				1.5	**			
1807020601	CELL ASSEMBLY	INSPECT					**	20, 21		
		REPLACE					**			
		REPAIR					**			
180703	OBJECTIVE AND DIAPHRAGM SUB-ASSEMBLY	INSPECT				0.3	**	20, 21		
		ADJUST				4.0	**			
		REPAIR				9.2	**			
18070302	CELL AND HOUSING ASSEMBLY	INSPECT					**	20, 21		
		REPAIR					**			

**SECTION II. MAINTENANCE ALLOCATION CHART - Cab Armament, Sighting and Fire Control, Elevating And Traversing Systems And Associated Components. - Continued**

(1) GROUP NUMBER	(2) COMPONENT/ ASSEMBLY	(3) MAINTENANCE FUNCTION	(4) MAINTENANCE LEVEL					(5) TOOLS AND EQUIPMENT REF CODE	(6) REMARKS CODE
			FIELD		SUSTAINMENT				
			UNIT		DS	GS	DEPOT		
			C	O	F	H	D		
1808	MOUNT, TELESCOPE M145/M145A1	INSPECT	0.2	0.2	0.2	0.2	**	4, 20, 21	
		SERVICE		0.5			**	4, 10	
		ADJUST		2.5			**	4, 20, 21, 35-37	
		REPLACE		1.0			**	4, 20, 21, 35	
		REPAIR		3.0		23.5	**	4, 20, 21, 35	
		OVERHAUL					**	4, 20, 21, 29, 35	
180801	HOUSING ASSEMBLY	INSPECT				0.2	**		
		REPAIR				2.0	**	20, 21	
180802	DISK ASSEMBLY	INSPECT		0.1	0.1		**	4	
		REPAIR		0.5		2.0	**	4, 20, 21	
180803	LEVEL ASSEMBLY	INSPECT		0.2	0.2			4	
		ADJUST			0.5			20	
		REPLACE				1.5		20	
		REPAIR		0.5		3.0		4, 20, 21	
180804	QUADRANT SUPPORT ASSEMBLY	INSPECT		0.1		0.2	**		
		REPLACE		0.5		1.0	**	20, 21	
		REPAIR				4.0	**	4, 20, 21,	
		ADJUST			0.5			20, 21, 35	
180805	COUNTER BOX ASSEMBLY	INSPECT		0.1	0.2	0.1	**	4	
		REPLACE				1.0		20, 21	
		REPAIR		1.0		5.0	**	4, 20, 21	
180806	SEGMENT ASSEMBLY	INSPECT				0.1			
		REPLACE				1.0		20, 21	
		REPAIR				2.0		20, 21	
1809	TELESCOPE, PANORAMIC M117/M117A2	INSPECT	0.2	0.2	0.2	1.5		4, 20, 21	
		SERVICE		0.5				4, 10	
		ADJUST			1.0			20, 21, 35, 38, 39	
		REPLACE		0.5				4	
		REPAIR		1.0		18.0		4, 20, 21, 40	
		OVERHAUL					**	20, 21, 29, 32, 35, 38-41	
180901	CAP ASSEMBLY	INSPECT				0.2			
		REPLACE				1.0		20	
		REPAIR				1.0		20	

**SECTION II. MAINTENANCE ALLOCATION CHART - Cab Armament, Sighting and Fire Control, Elevating And Traversing Systems And Associated Components. - Continued**

(1)  GROUP NUMBER	(2)  COMPONENT/ ASSEMBLY	(3)  MAINTENANCE FUNCTION	(4) MAINTENANCE LEVEL					(5) TOOLS AND EQUIPMENT REF CODE	(6) REMARKS CODE	
			FIELD		SUSTAINMENT					
			UNIT		DS	GS	DEPOT			
			C	O	F	H	D			
180903	LAMP ASSEMBLY	INSPECT		0.1	0.1			4		
		REPLACE			0.2			20		
		REPAIR		0.2		0.5		4, 20, 21, 40		
180904	HOUSING ASSEMBLY	INSPECT		0.1		0.1	**			
		REPAIR		0.5		1.0	**	4, 20		
180905	TUBE ASSEMBLY	INSPECT					**			
		REPAIR					**	20, 21		
180906	ELBOW ASSEMBLY	INSPECT		0.1		0.1	**	4		
		REPAIR		0.5		2.0	**	4, 20, 21		
18090601	CELL ASSEMBLY	INSPECT				0.1				
		REPAIR				0.5		20, 21		
18090602	ELBOW	INSPECT				0.1	**			
		REPAIR				1.0	**	20		
180907	DOVE PRISM ASSEMBLY	INSPECT				0.1	**			
		REPLACE				1.5		20		
		REPAIR					**	20		
18090701	PRISM, OPTICAL/ INSTRUMENT	ADJUST					**	20, 32, 41		
		INSPECT					**			
		REPLACE					**	20, 21		
18090702	SUPPORT, PINNED MACHINED	REPAIR					**	20, 21		
		INSPECT					**			
		REPAIR					**	20, 21		
180908	COUNTER ASSEMBLY	INSPECT				0.2				
		REPAIR				8.0		20, 21		
18090801	ADAPTER ASSEMBLY	INSPECT				0.2				
		REPAIR				6.0		20, 21		
1809080101	COUNTER ASSEMBLY	INSPECT				0.1				
		REPLACE				1.5		20, 21		
		REPAIR				1.0		20, 21		
1809080102	GEAR ASSEMBLY	INSPECT				0.1				
		REPLACE				0.5		20, 21		
		REPAIR				0.5		20, 21		
180909	TUBE ASSEMBLY	INSPECT					**			
		REPAIR					**	20, 21		

**SECTION II. MAINTENANCE ALLOCATION CHART - Cab Armament, Sighting and Fire Control, Elevating And Traversing Systems And Associated Components. - Continued**

(1) GROUP NUMBER	(2) COMPONENT/ ASSEMBLY	(3) MAINTENANCE FUNCTION	(4) MAINTENANCE LEVEL					(5) TOOLS AND EQUIPMENT REF CODE	(6) REMARKS CODE
			FIELD		SUSTAINMENT				
			UNIT		DS	GS	DEPOT		
			C	O	F	H	D		
1810	M15 QUADRANT	INSPECT	0.1	0.1	0.1	1.0			
		SERVICE		0.2			4, 10		
		REPLACE		0.5			4		
		REPAIR		0.7		20.0	4, 20, 21, 37, 42		
181001	CORRECTION KNOB ASSEMBLY	INSPECT			0.1		20		
		ADJUST			0.1		20, 21		
		REPLACE			0.2		20, 21		
		REPAIR				1.0			
181002	COVER ASSEMBLY	INSPECT			0.1				
		REPAIR				1.5			
181003	COUNTER ASSEMBLY	INSPECT			0.1	0.1			
		ADJUST				0.2	20		
		REPLACE				1.0	20, 21		
		REPAIR				4.5	20, 21		
18100301	BASE	INSPECT			0.1				
		REPAIR			0.2		20, 21		
181004	LEVEL ASSEMBLY	INSPECT		0.1	0.1		4		
		ADJUST				0.3	20		
		REPAIR		0.2	0.5		4, 20, 21, 35		
1811	PERISCOPE M42	INSPECT	0.1	0.1		0.5	4, 20, 21		
		SERVICE		1.0			4, 10		
		REPLACE		1.5			4		
		REPAIR	0.7			2.5	20, 21		
		ALINE				1.0	20, 21, 32, 34		
1812	LINKAGE ASSEMBLY	INSPECT		0.2			**	4	
		ADJUST		2.0				4, 20	
		REPLACE		1.0				4, 20	
		REPAIR		3.0		3.0	**	4, 20, 21	
181201	LINK	INSPECT					**		
		REPAIR					**	20, 21	

**SECTION III. TOOLS AND TEST EQUIPMENT**

TOOL OR TEST EQUIPMENT REF CODE	MAINTENANCE LEVEL	NOMENCLATURE	NATIONAL STOCK NUMBER	TOOL NUMBER
1	F	HOIST, CAB LIFTING	3950-00-889-8746	MIL-H-904
2	F	SLING ASSY, LIFTING CAB	4910-00-776-8906	8387711
3	F, H	TOOL KIT ARTILLERY FIELD MAINTENANCE	4933-00-348-7398	CL 4933-95-A06
4	O,F,H,D	TOOL KIT ARTILLERY TURRET MECHANIC'S	5180-00-357-7727	CL 5180-95-A12
5	F,H	TOOL KIT ARTILLERY FIELD MAINTENANCE SUPPLEMENTAL NO. 1	5180-00-754-0659	CL 5180-95-1320
6	F, H	SHOP EQUIPMENT ARTILLERY MAINTENANCE	4933-00-754-0704	CL 4933-95-A12
7	F	TOOL KIT, FIELD ARTILLERY REPAIRMAN	5180-00-699-3595	CL 5180-95-A13
8	C, O, F, H	T-HANDLE	5340-01-318-0197	9399097
9	O	SHOP EQUIPMENT, AUTOMOTIVE MAINTENANCE AND REPAIR:ORGANIZATIONAL MAINTENANCE COMMON NO. 2, LESS POWER	4910-00-754-0650	CL 4910-95-A72
10	O	SETS, KITS, AND OUTFITS, COMPONENTS LIST, PURGING KIT, FIRE CONTROL FOR ORGANIZATIONAL, DIRECT AND GENERAL SUPPORT MAINTENANCE	4931-00-065-1110	CL 4931-95-J54
11	O	SHOP EQUIPMENT, AUTOMOTIVE MAINTENANCE AND REPAIR:ORGANIZATIONAL MAINTENANCE COMMON NO. 1, LESS POWER	4910-00-754-0654	CL 4910-95-A74
12	O	WRENCH, SOCKET, HYDRAULIC POWERPACK FILTER SCREEN	5120-00-976-3105	10930422
13	F	SLING ASSY, LIFTING, POWERPACK	4910-00-076-3104	10930417
14	O, F	NITROGEN CHARGING KIT	1025-01-070-3200	8449334
15	O	EXTENSION VALVE	5120-00-051-5566	11605630
16	H	ADAPTER, TORQUE	5120-00-933-7357	10954669
17	F	SOCKET, SOCKET WRENCH CAB TRAVERSING MECHANISM CLUTCH	5120-00-055-9255	10931103
18	F	SLING ASSY, LIFTING, TRAVERSING MECHANISM	4910-00-678-8414	10942192
19	O	SHOP SET, SMALL ARMS: FIELD MAINTENANCE, BASIC LESS POWER	4933-00-754-0664	CL 4933-95-A11
20	F	TOOL KIT, ELECTRONIC SYSTEM REPAIR, FIELD MAINTENANCE	5180-01-168-0487	CL 5180-95-B29

**SECTION III. TOOLS AND TEST EQUIPMENT - CONTINUED**

TOOL OR TEST EQUIPMENT REF CODE	MAINTENANCE LEVEL	NOMENCLATURE	NATIONAL STOCK NUMBER	TOOL NUMBER
21	F, H	SHOP EQUIPMENT, INSTRUMENT & FIRE CONTROL FIELD MAINT LESS POWER	4931-00-754-0740	CL 4931-95-A07
22	H	WRENCH (SPECIAL)	4931-01-113-7875	8565852
23	H	WRENCH (SPECIAL)	4931-01-113-7874	8565858
24	H	FIXTURE TELESCOPE TEST	4931-00-508-5443	7573980
25	H	RETICLE CELL ADAPTER		
26	H	COLLIMATOR HOLDING CLAMP		
27	H	BRACKET		
28	H	ADAPTER	4931-00-346-8311	7680680
29	D	VIBRATION TESTER	4931-00-536-5555	7560085
30	H	GREASE GUN PNEUMATIC	4931-00-764-8134	7648134
31	H	GREASE GUN INJECTION ADAPTER	4930-00-132-4883	11727577
32	H	COLLIMATOR, INFINITY AIMING REFERENCE	1240-00-757-3291	7573291
33		DELETED		
34	H	FIXTURE, TELESCOPE, TESTING	4931-00-020-2367	5800949
35	F	LEVEL, PRECISION	5120-00-546-6362	7686087
36	H	ADAPTER, FIXTURE W/CARRYING CASE	4931-00-034-0897	5800953
37	H	FIXTURE, CROSS LEVELING AND ELEVATION	4931-00-508-5484	7681019
38	H	COLLIMATOR, TELESCOPE W/ACCESSORY CASE	4931-00-020-2365	5800955
39	H	FIXTURE, TELESCOPE TESTING	4931-00-769-1596	7691596
40	F	MINI GUN, HOT AIR	4940-00-307-2745	CV5300
41	H	FIXTURE, TEST, TELESCOPE	4931-00-508-5434	7197944
42	H	FIXTURE, TELESCOPE, TESTING	4931-00-884-7752	8213745
43	D	FIXTURE, TELESCOPE TESTING	4931-00-020-2366	5800952
44	O, F, H	TOOL KIT, GENERAL MECHANIC'S: AUTOMOTIVE (GMTK)	5180-00-177-7033	CL 5180-90-N26

**SECTION IV. REMARKS**

CODE	REMARK
	None



## **APPENDIX C**

### **REPAIR PARTS AND SPECIAL TOOLS LIST**

For repair parts and specials tools list, refer to:

TM9-2350-311-24P-2, Organizational, Direct Support and General Support Maintenance Repair Parts and Special Tools List (Including Depot Maintenance Repair Parts and Special Tools) for Cab, Armament, Sighting And Fire Control, Elevating and Traversing Systems, and Associated Components Howitzer, Medium, Self-Propelled: 155MM M109A2 (NSN 2350-01-031-0586), M109A3 (NSN 2350-01-031-8851), M109A4 (NSN 2350-01-277-5771), M109A5 (NSN 2350-01-281-1719).



## APPENDIX D EXPENDABLE AND DURABLE ITEMS LIST

### SECTION I. INTRODUCTION

#### D-1 SCOPE

This appendix lists expendable and durable items you will need to maintain the 155MM self-propelled howitzer at organizational level. This listing is for informational purposes only and is not authority to requisition the listed items. This items are authorized to you by CTA 50-970, Expendable Items (except Medical, Class V, Repair Parts, and Heraldic Items).

#### D-2 EXPLANATION OF COLUMNS

- a. Column (1) – Item Number. This number is assigned to the entry in the listing for referencing when required.
- b. Column (2) – Level. This column identifies the lowest level of maintenance that requires the listed item.
  - C ..... Operator or Crew Maintenance
  - O ..... Unit Maintenance
  - F ..... Direct Support Maintenance
  - H ..... General Support Maintenance
- c. Column (3) – National Stock Number. This is the national stock number assigned to the item.; use it to request the item.
- d. Column (4) – Description. Indicates the federal item name and, if required, a description to identify the item. The last line for each item indicates the Commercial and Government Entity Code (CAGEC) in parentheses followed by the part number.
- e. Column (5) – Unit of Measure (U/M)/Unit of Issue (U/I). This measure is expressed by a two-character alphabetical abbreviation (e.g. EA, IN, PR). If the unit of measure differs from the unit of issue as shown in the Army Master Data File (AMDF) requisition the lowest unit of issue that will satisfy your requirements.

### SECTION II. EXPENDABLE AND DURABLE ITEM LIST

(1) Item Number	(2) Level	(3) National Stock Number	(4) Description	(5) (U/M)/ (U/I)
1	O	8040-00-221-3811	Adhesive, reclaimed rubber, liquid, type II: (81348) MMM-A-1617	BT
2	O	8040-00-262-9026	Adhesive, type I: (81349) MIL-A-5092	PT
3	O	8040-00-262-9027	Adhesive, type I: (81349) MIL-A-5092	BT
4	O		Bag, plastic: A-A-1779	
5	O	8105-00-299-8532	Bag, plastic: (81348) PPP-B-26; 10 ea pkg	EA
6	O	8115-00-190-5020	Box, shipping: (81348) PPP-B-636; 10 ea pkg	EA

SECTION II. EXPENDABLE AND DURABLE ITEM LIST – CONTINUED

(1) Item Number	(2) Level	(3) National Stock Number	(4) Description	(5) (U/M)/ (U/I)
7	O	<p>5340-00-804-1234 5340-01-167-3943 5340-00-597-9433 5340-01-167-9321 5340-00-682-1857 5340-00-804-1236 5340-01-157-4193 5340-00-804-1253 5340-01-166-6861</p> <p>5340-01-206-5370 5340-00-804-1240 5340-01-154-2314 5340-01-154-7249 5340-00-804-1243 5340-01-142-3085 5340-01-146-9729 5340-01-138-2170 5340-00-804-1222 5340-00-804-1225</p> <p>5340-01-065-9917 5340-01-326-2579 5340-00-804-0753 5340-01-238-3768 5340-01-194-3200</p> <p>5340-01-203-7790 5340-00-804-7820 5340-01-082-3003 5340-01-107-7559 5340-01-183-0961 5340-01-170-6662 5340-01-227-5837 5340-01-187-8957 5340-01-302-9269 5340-00-827-0802 5340-01-167-9312 5340-01-044-2675 5340-01-PAC-8660 5340-00-597-4480 5340-00-576-0780 5340-01-215-0037 5340-01-208-7825 5340-01-219-6760</p>	<p>Cap and plug, dust protective: (81349) MIL-C-5501 Plugs:</p> <p>Plug, threaded: (81349) M5501/ 1-F2 ..... (.3125-24 UNF) 1-F3 ..... (.375-24 UNF) 1-F4 ..... (.4375-20 UNF) 1-F5 ..... (.500-20 UNF) 1-F6 ..... (.5625-18 UNF) 1-F8 ..... (.750-16 UNF) 1-F10 ..... (.875-14 UNF) 1-F16 ..... (1.3125-12 UNF) 1-F20 ..... (1.625-12 UNF)</p> <p>Plug, threaded: (81349) M5501/ 2-R2 ..... (.3125-24 UNF) 2-3 ..... (.375-24 UNF) 2-R4 ..... (.4375-20 UNF) 2-R5 ..... (.500-20 UNF) 2-6 ..... (.5625-18 UNF) 2-R8 ..... (.750-16 UNF) 2-R10 ..... (.875-14 UNF) 2-R12 ..... (1.0625-12 UNF) 2-16 ..... (1.3125-12 UNF) 2-20 ..... (1.625-12 UNF)</p> <p>Cap and Plug, non-threaded: (81349) M5501/ 7-F2 ..... (1/8 inch) 7-F4 ..... (1/4 inch) 7-F8 ..... (1/2 inch) 7-F21 ..... (1 inch) 7-F23 ..... (1 3/8 inch) 7-F25 ..... (1 1/2 inch)</p> <p>Cap, non-threaded: (81349) M5501/ 9-F2 ..... (1/8 inch) 9-F3 ..... (5/32 inch) 9-F4 ..... (3/16 inch) 9-F5 ..... (1/4 inch) 9-F6 ..... (5/16 inch) 9-F7 ..... (3/8 inch) 9-F8 ..... (7/16 inch) 9-F9 ..... (1/2 inch) 9-F10 ..... (9/16 inch) 9-F11 ..... (5/8 inch) 9-F12 ..... (11/16 inch) 9-F13 ..... (3/4 inch) 9-F14 ..... (13/16 inch) 9-F15 ..... (7/8 inch) 9-F16 ..... (1.0 inch) 9-F17 ..... (1 1/8 inch) 9-F18 ..... (1 1/4 inch, .62 inch deep) 9-F19 ..... (1 1/4 inch, 1.0 inch deep)</p>	

**SECTION II. EXPENDABLE AND DURABLE ITEM LIST - CONTINUED**

(1) Item Number	(2) Level	(3) National Stock Number	(4) Description	(5) (U/M)/ (U/I)
7 (Cont)			Cap and plug, dust protective: (81349) MIL-C-5501 Plugs (Cont):  Cap, threaded: (81349) M5501/ 11-F2 ..... (.3125-24 UNF) 11-F3 ..... (.375-24 UNF) 11-F4 ..... (.4375-20 UNF) 11-F5 ..... (.50-20 UNF) 11-F6 ..... (.5625-18 UNF) 11-F7 ..... (.625-18 UNF) 11-F8 ..... (.625-24 UNF) 11-F9 ..... (.75-16 UNF) 11-F10 ..... (.75-20 UNF) 11-F11 ..... (.875-14 UNF) 11-F12 ..... (1.0625-12 UNF) 11-F13 ..... (1.125-18 UNF) 11-F14 ..... (1.250-18 UNF) 11-F15 ..... (1.3125-12 UNF) 11-F16 ..... (1.375-18 UNF) 11-F17 ..... (1.625-12 UNF)	
8	O	9150-01-053-6688	Cleaner, lubricant, preservative (CLP) grade 2: (81349) MIL-L-63460	GL
9	O	6850-00-256-0157	Cleaning compound, powder: (81348) P-C-437	LB
9.1	O	7930-01-328-2030 7930-01-328-4058	Cleaning compound, solvent - detergent: (0JVH6) PF DEGREASER 5 gal. 55 gal. drum	GL DR
10	O	7920-00-044-9281	Cloth, cleaning, low lint: MIL-G-85043	PG
11	O	5350-00-221-0872	Cloth, abrasive crocus, 50 sheets: (81348) PC458	PG
11.1	O	6850-00-680-2233	Dessicant	CN
12			DELETED	
13	O	8010-00-133-5706	Enamel (81349)	QT
13.1	O		Epoxy 12984469	
13.2	O		Epoxy 12984446	
14	O	4730-00-050-4208	Fittings, lubrication (81349) MS15003-1	EA
15	O	3439-00-009-8808	Flux, soldering: (81349) MIL-F-14256	QT
16	O	6515-01-150-2977 6515-01-150-2978 6515-01-150-2976	Gloves, patient, exam: package of 100 (89875) Size large, E-011 Size medium, E-012 Size small, E-010	PG PG PG
17	O	9150-01-197-7693	Grease, automotive art (GAA) 14 oz. cartridge: (81349) MIL-G-10924 MIL-PRF-10924	CA
18	O	9150-01-197-7690	Grease, automotive art (GAA) 1.75-lb can BRAYCOTE610: (98308) MIL-PRF-10924	CN

**SECTION II. EXPENDABLE AND DURABLE ITEM LIST - CONTINUED**

(1) Item Number	(2) Level	(3) National Stock Number	(4) Description	(5) (U/M)/ (U/I)
19	O	9150-00-985-7316	Grease, general purpose (GGP): (81349) MIL-G-23549	CN
20	O	9150-00-754-2595	Grease, molybdenum disulfide for low and high temperatures (GMD): (81349) MIL-G-21164	CN
20.1	O	9150-00-111-6255	Hydraulic fluid: (81349) MIL-H-46170	CN
21	O	9150-00-935-9808	Hydraulic fluid, PET, OHT: (98308) MIL-H-6083 BRAYC0783C	GL
22	O	6800-00-264-9086	Nitrogen, dry, high pressure: BB-N-411	BT
23	O	8010-00-515-2208	Paste, zinc chromate	EA
24	O	8010-00-936-3372	Primer, paint	EA
25	O	7920-00-205-1711	Rag, wiping: (81348) DDD-R-30	BE
26	O		Rope MIL-R-17343-1/2	
26.1	O	1015-01-255-4144	Sealant, teflon pipe: (19207) 12297953	RL
26.2	O		Sealant: 12984469	
27	O	8030-00-252-3391	Sealing compound A gasket No. 2 (77247)	OZ
28	O	8030-00-275-8114	Sealing compound, adhesive, noncuring, polysulfide base, type I (80064) 1941316	OZ
28.1	O	8030-00-275-8115	Sealing compound (81349) MIL-S-11030	PT
28.2	O	8030-00-058-5398	Sealing compound, grade B: MIL-S-22473	CC
29	O	8030-00-081-2333	Sealing compound, grade C, liquid, blue: MIL-S-22473	BT
30	O	8030-00-823-7917	Sealing compound, grade C, liquid, blue: MIL-S-22473	BT
31	O	8030-00-824-1384	Sealing compound, grade C, liquid, blue: MIL-S-22473	PT
32	O	8030-00-209-8005	Sealing compound, thread, hydraulic fluid compatible (CE): MIL-A-12352A	GL
33	O	8030-00-209-8005	Soap, toilet, liquid: (81348) P-S-624	GL
34	O	3439-01-094-3338	Solder, tin alloy, rosin core: (81348) SN60WRAP1	OZ
35	O	5340-00-980-9277	Strap, webbing, tie-down, cargo, aircraft	EA
36	O	9905-00-537-8954	Tag, marking: (81349) MIL-T-12755CLRW	
37	O	7510-00-198-5831	Tape masking: (53578) 3842G	RO
38	O	7510-01-146-7767	Tape, pressure sensitive: 2 inches, 5.08 cm wide, 60 yds (64.86 m) (81348) PPP-T-60	YD/RO

**SECTION II. EXPENDABLE AND DURABLE ITEM LIST – CONTINUED**

(1) Item Number	(2) Level	(3) National Stock Number	(4) Description	(5) (U/M)/ (U/I)
39.1	O	5510-00-120-6226	Wood, block, 4" x 4" x 12 "	EA
40	O	5510-00-223-0953	Wood, dowel 1 x 12	EA

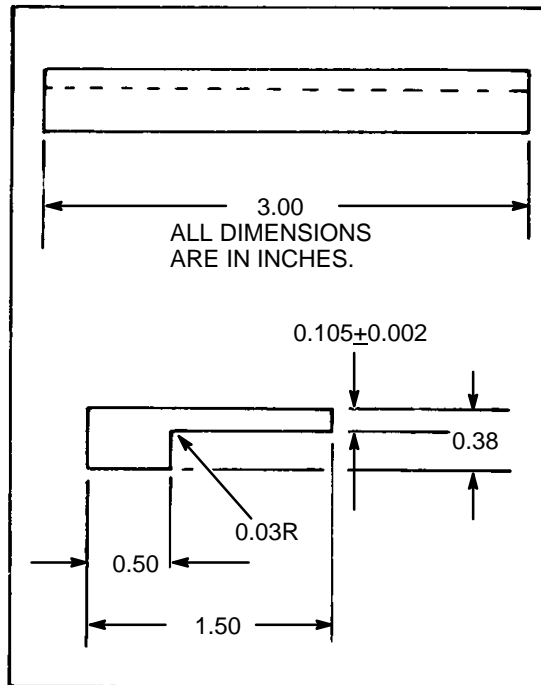




## APPENDIX E ILLUSTRATED LIST OF MANUFACTURED ITEMS

### GENERAL

This appendix includes complete instructions for making items authorized to be manufactured or fabricated at unit maintenance level.



BRUSH SETTING GAGE – FABRICATE FROM ANY ELECTRICAL NONCONDUCTIVE MATERIAL.

**NOTE**

TWO GAGES ARE REQUIRED. USE ONE ON EACH SIDE OF CONTACT ARM ASSEMBLY.

**Figure E-1. Contact Brush Adjustment Gage**

ILLUSTRATED LIST OF MANUFACTURED ITEMS – CONTINUED

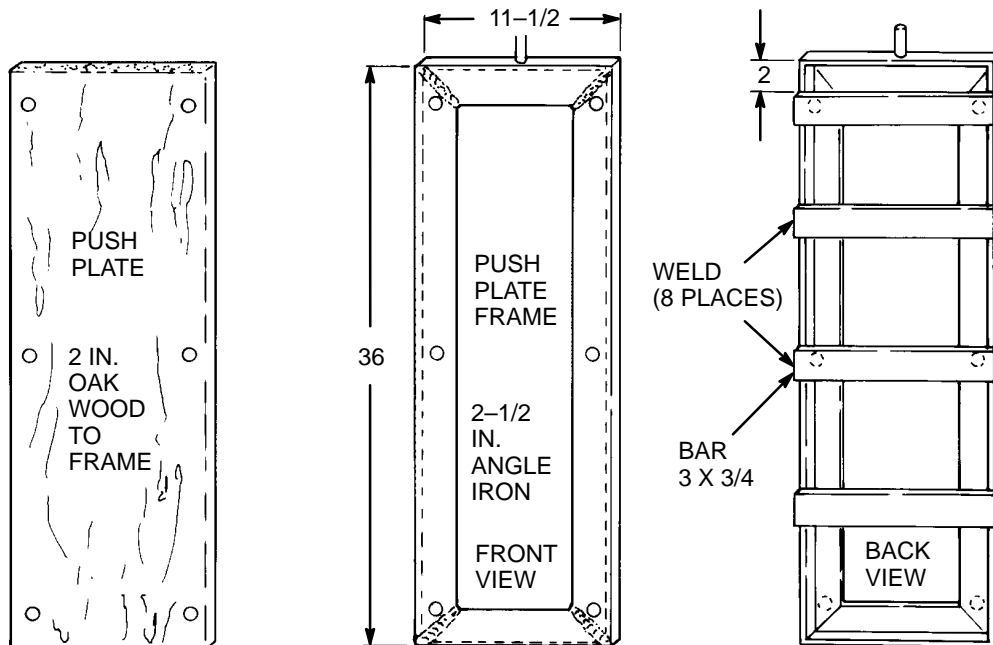
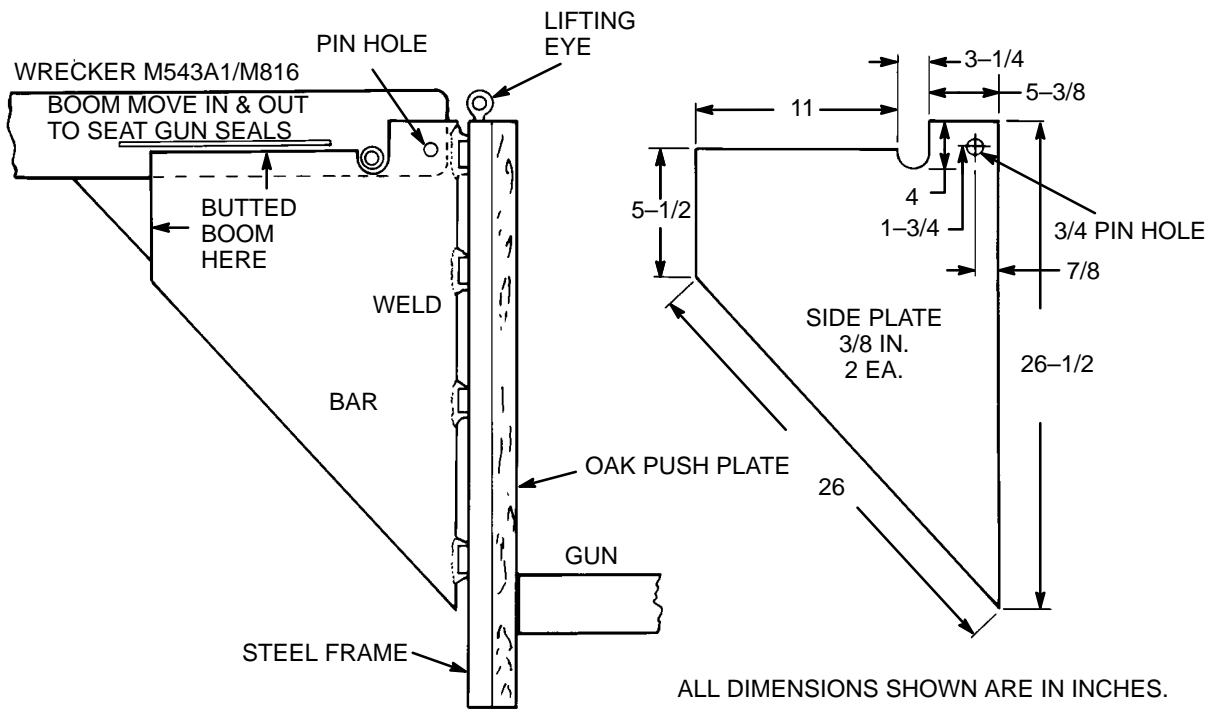
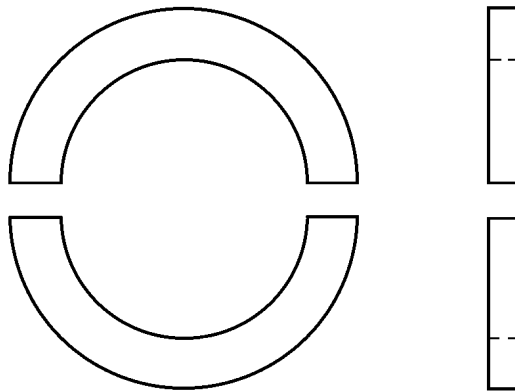


Figure E-2. Dimensional Drawing for Fabricating Improved Recoil Mechanism Exercising Bracket (M543A2/M816 Wrecker)

- 1 Cut one flat washer (P/N 11605242) in half.
- 2 Ensure spacers are free of burrs and sharp edges.



**Figure E-3. Spacer**



## APPENDIX F TORQUE LIMITS

---

### GENERAL

This appendix provides general torque limits for screws used on the M109A2/M109A3/M109A4/M109A5 Howitzer. Specific torque limits are indicated in the maintenance procedures for applicable components. The general torque limits given in this appendix shall be used when specific torque limits are not indicated in the maintenance procedure.

These general torque limits cannot be applied to screws that retain rubber components. The rubber components will be damaged before the correct torque limit is reached. If a specific torque limit is not given in the maintenance instructions, tighten the screw or nut until it touches the metal bracket, then tighten it one more turn.

This appendix also provides information on tightening metal fasteners, fastener size and thread pattern, and fastener grade.

---

<u>CONTENTS</u>	<u>Page</u>
F-1 TORQUE LIMITS .....	F-2
F-2 HOW TO USE TORQUE TABLES .....	F-2
F-3 TIGHTENING METAL FASTENERS .....	F-4
F-4 FASTENER SIZE AND THREAD PATTERN .....	F-4
F-5 FASTENER GRADE .....	F-5

---

## F-1 TORQUE LIMITS

---

Table F-1 lists wet torque limits. Wet torque limits are used on screws that have high-pressure lubricants applied to the threads.

---

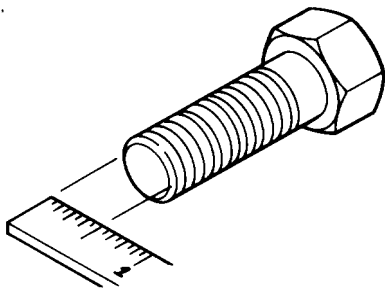
## F-2 HOW TO USE TORQUE TABLE

---

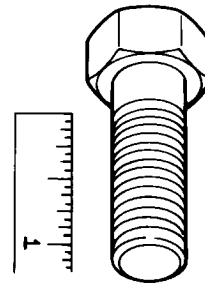
- a. Measure diameter of screw you are installing.
- b. Count the number of threads per inch or use a pitch gage.
- c. Under heading "SIZE", look down the left hand column until you find the diameter of the screw being installed (there will usually be two lines beginning with the same size).
- d. In the second column under "SIZE", find the number of threads per inch that matches the number of threads counted in step b.
- e. To find the grade screw being installed, match markings on the head to the correct picture of cap screw head markings on the torque table.
- f. Look down the column under the picture found in step e, until you find the torque limit in lb-ft or N-m for the diameter and threads per inch of the screw being installed.

### NOTE

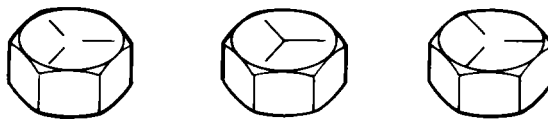
Manufacturer's cap screw head marking may vary. These are all SAE grade 5 (3 line).



MEASURING DIAMETER

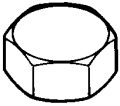
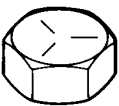
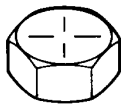
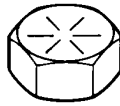


COUNTING THREADS/IN.



SAE GRADE 5 (3 LINE) MARKINGS

Table F-1 TORQUE LIMITS FOR WET FASTENERS

SIZE			TORQUE							
			SAE GRADE NO. 1 OR 2		SAE GRADE NO. 5		SAE GRADE NO. 6 OR 7		SAE GRADE NO. 8	
										
DIA. IN.	THREADS PER INCH	DIA MM	LB-FT	N•M	POUND- FEET	N•M	LB-FT	N•M	LB-FT	N•M
1/4	20	6.35	4.9	6.64	7.2	9.76	9.0	12.20	10.8	14.64
1/4	28	6.35	5.4	7.32	9.0	12.20	-	-	12.6	17.09
5/16	18	7.94	9.9	13.42	15.3	20.75	17.1	23.19	21.6	29.30
5/16	24	7.94	11.7	15.87	17.1	23.18	-	-	24.3	32.95
3/8	16	9.53	16.2	21.97	27.9	37.83	30.6	41.49	39.6	53.70
3/8	24	9.53	18.0	24.41	31.5	42.71	-	-	44.1	59.80
7/16	14	11.11	25.2	34.17	44.1	59.80	49.5	67.12	63.0	85.43
7/16	20	-	27.0	36.61	49.5	67.12	-	-	70.2	95.19
1/2	13	12.70	35.1	47.60	67.5	91.53	76.5	103.73	94.5	128.14
1/2	20	-	36.9	50.04	76.5	103.73	-	-	108.0	146.45
9/16	12	14.29	45.9	62.24	99.0	134.24	108.0	146.45	139.5	189.16
9/16	18	-	49.5	67.12	108.0	146.45	-	-	153.0	207.47
5/8	11	15.88	56.7	76.89	135.0	183.06	150.3	203.81	189.0	256.28
5/8	18	-	85.5	115.94	153.0	207.47	-	-	216.0	292.90
3/4	10	19.05	94.5	128.14	243.0	329.51	252.0	341.71	337.5	457.65
3/4	16	-	103.5	140.35	265.5	360.02	-	-	378.0	512.57
7/8	9	22.23	144.0	195.26	355.5	482.06	396.0	536.98	544.5	738.34
7/8	14	-	157.5	213.57	391.5	530.87	-	-	607.5	823.77
1	8	25.40	211.5	286.79	531.0	720.04	594.0	805.46	819.0	1110.56
1	14	-	225.0	305.10	594.0	805.46	-	-	891.0	1208.20
1-1/8	-	25.58	-	-	720.0	976.32	-	-	1152.0	1562.11
					792.0	1073.95			1296.0	1757.38
1-1/4	-	31.75	-	-	-	-	-	-	1638.0	2221.13
									1800.0	2440.80
1-3/8	-	34.93	-	-	1314.0	1781.78	-	-	2142.0	2904.55
					1512.0	2050.27			2448.0	3319.49
1-1/2	-	38.10	-	-	1746.0	2367.58	-	-	2844.0	3856.46
					1980.0	2684.88			3204.0	4344.62

### F-3 TIGHTENING METAL FASTENERS

When torquing a fastener, select a torque wrench whose range (Table F-2) fits the required torque value. A torque wrench is most accurate from 25% to 75% of its stated range. A torque wrench with a stated range of 0 to 100 lb-ft will be most accurate from 25 to 75 lb-ft. Accuracy of readings will decrease as you approach 0 lb-ft or 100 lb-ft. The following ranges are based on this principle.

Table F-2 TORQUE RANGES

STATED RANGE	MOST EFFECTIVE RANGE
0-18 lb-ft (0-24 N·m)	4-13 lb-ft (5-18 N·m)
0-600 lb-ft (0-813 N·m)	50-450 lb-ft (68-610 N·m)
0-170 lb-ft (0-230 N·m)	44-131 lb-ft (60-178 N·m)
15-75 lb-ft (20-102 N·m)	30-60 lb-ft (41-81 N·m)

### F-4 FASTENER SIZE AND THREAD PATTERN

Threaded fasteners are categorized according to diameter of the fastener shank. Thread styles are divided into broad groups, the two most common being coarse (Unified Coarse-UNC) and fine (Unified Fine-UNF). These groups are defined by the number of threads per inch on the bolt shanks. In addition, threads are categorized by thread class (Table F-3), which is a measure of the degree of fit between the threads of the bolt or screw (external threads) and the threads of the attaching nut or tapped hole (internal threads). The most common thread class for bolts and screws is class 2.

Table F-3 THREAD CLASSES AND DESCRIPTION

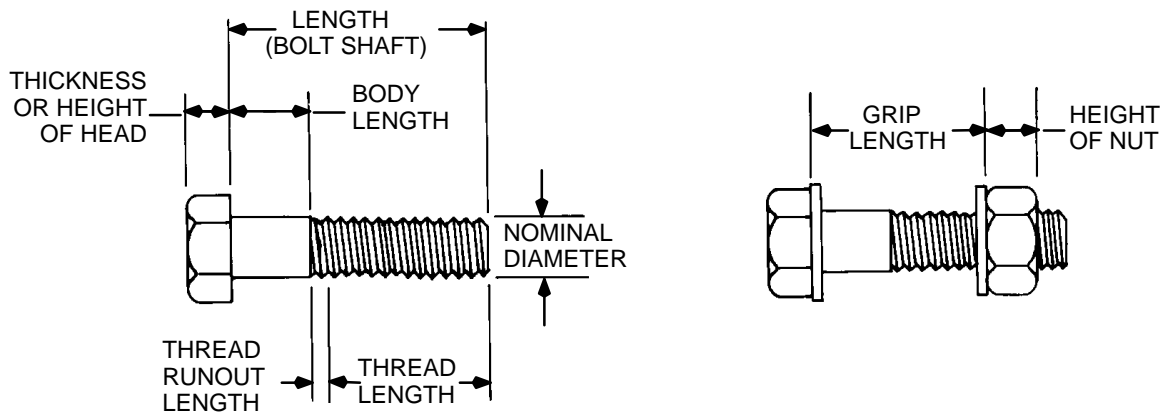
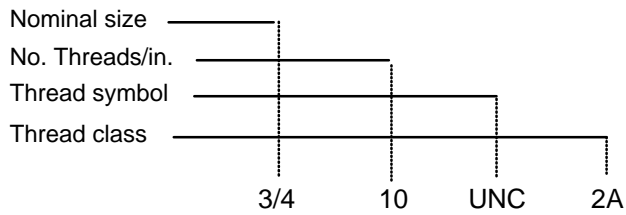
EXTERNAL	INTERNAL	FIT
1A	1B	Loose fit
2A	2B	Medium fit
3A	3B	Close fit



Thread patterns are designed as follows:

**NOTE**

Unless followed with -LH (e.g., 3/4-10 UNC-2A-LH), threads are right-handed.




---

**F-5 FASTENER GRADE**

---

In addition to being classified by thread type, threaded fasteners are also classified by material. The most familiar fastener classification system is the SAE grading system (Table F-4). ■

**F-5 FASTENER GRADE — CONTINUED**

Table F-4 SAE SCREW AND BOLT MARKINGS

SCREWS	BOLTS
<p>SAE grade 2 No markings</p> <p>SAE grade 3 Two radial dashes 180° apart</p> <p>SAE grade 5 Three radial dashes 120° apart</p>	<p>SAE grade 6 Four radial dashes 90° apart</p> <p>SAE grade 7 Five radial dashes 72° apart</p> <p>SAE grade 8 Six radial dashes 60° apart</p>

MARKINGS ON HEX LOCKNUTS

Grade A – no marks

Grade B – three marks

Grade C – six marks

Grade A – no marks

Grade B – letter B

Grade C – letter C

Grade A – no notches

Grade B – one notch

Grade C – two notches

## APPENDIX G MANDATORY REPLACEMENT PARTS LIST

### G-1 SCOPE

This appendix is a cross-reference of item numbers to part numbers and is included for that purpose only.

### G-2 EXPLANATION OF COLUMNS

- a. Column (1) – Item Number. This number is assigned to the entry in the listing for cross-referencing to the part number.
- b. Column (2) – Part Number. Indicates the primary number used by the manufacturer (individual, company, firm, corporation, or Government activity), which controls the design and characteristics of the item by means of its engineering drawings, specification, standards, and inspection requirements to identify an item or range of items.
- c. Column (3) – Description. This column contains the nomenclature which appears on the first page of the task under the subheading “Materials/Parts”.

### G-3 MANDATORY REPLACEMENT PARTS LIST

ITEM #	PART NUMBER	NOMENCLATURE
1	AN365-448A	Nut, self-locking
2	AN6289-4	Nut, lock
3	AN6289-6	Nut, lock
4	MS16555-66	Pin, straight headless
5	MS16562-109	Pin, spring
6	MS16562-123	Pin, spring
6.1	MS16562-129	Pin, spring
7	MS16562-135	Pin, spring
8	MS16562-139	Pin, spring
9	MS16562-18	Pin, spring
10	MS16562-224	Pin, spring
10.1	MS16562-227	Pin, spring
11	MS16562-28	Pin, spring

## G-3 MANDATORY REPLACEMENT PARTS LIST – CONTINUED

ITEM #	PART NUMBER	NOMENCLATURE
11.1	MS16562-29	Pin, spring
11.2	MS16562-33	Pin, spring
11.3	MS16562-30	Pin, spring
12	MS16562-35	Pin, spring
13	MS16562-36	Pin, spring
14	MS16562-38	Pin, spring
15	MS16562-41	Pin, spring
16	MS16562-42	Pin, spring
17	MS16562-72	Pin, spring
18	MS16562-78	Pin, spring
19	MS16562-90	Pin, spring
20	MS16625-1062	Ring, retaining
21	MS16626-1112	Ring, retaining
21.1	MS16633-1012	Ring, retaining
21.2	MS16997-30L	Screw, self-locking
22	MS16997-49L	Screw, self-locking
22.1	MS16997-50	Screw, self-locking
23	MS16998-42L	Screw, self-locking
24	MS171531	Pin, spring
25	MS171572	Pin, spring
26	MS172204	Washer, key
27	MS17795-122	Bearing, sleeve
28	MS17829-14C	Nut, self-locking
29	MS17829-3C	Nut, self-locking
30	MS18582-97	Pin, spring
31	MS20995C32	Lockwire
32	MS20995C41	Lockwire

ITEM #	PART NUMBER	NOMENCLATURE
33	MS20995F41	Lockwire
34	MS21044-N5	Nut, self-locking
35	MS21044-N6	Nut, self-locking
36	MS24665-281	Pin, cotter
37	MS24665-283	Pin, cotter
38	MS24665-285	Pin, cotter
38.1	MS24665-298	Pin, cotter
39	MS24665-353	Pin, cotter
40	MS24665-441	Pin, cotter
41	MS24665-625	Pin, cotter
42	MS25196-1	Packing
43	MS28778-10	Packing, preformed
44	MS28778-12	Packing, preformed
45	MS28778-16	Packing, preformed
46	MS28778-4	Packing, preformed
47	MS28778-6	Packing, preformed
48	MS28778-8	Packing, preformed
49	MS29513-153	Packing, preformed
50	MS29513-210	Packing, preformed
51	MS35333-36	Washer, lock
52	MS35333-37	Washer, lock
53	MS35333-38	Washer, lock
54	MS35333-39	Washer, lock
55	MS35333-40	Washer, lock
56	MS35333-42	Washer, lock
56.1	MS35333-44	Washer, lock
57	MS35333-46	Washer, lock
58	MS35333-69	Washer, lock
58.1	MS35333-70	Washer, lock

---

**G-3 MANDATORY REPLACEMENT PARTS LIST – CONTINUED**


---

ITEM #	PART NUMBER	NOMENCLATURE
59	MS35333-72	Washer, lock
60	MS35334-20	Washer, lock
61	MS35335-30	Washer, lock
62	MS35335-31	Washer, lock
63	MS35335-32	Washer, lock
64	MS35335-33	Washer, lock
65	MS35335-37	Washer, lock
66	MS35336-15	Washer, lock
67	MS35336-21	Washer, lock
68	MS35336-27	Washer, lock
69	MS35338-135	Washer, lock
70	MS35338-136	Washer, lock
71	MS35338-137	Washer, lock
72	MS35338-141	Washer, lock
73	MS35338-143	Washer, lock
74	MS35338-145	Washer, lock
75	MS35338-161	Washer, lock
76	MS35338-41	Washer, lock
77	MS35338-42	Washer, lock
78	MS35338-43	Washer, lock
79	MS35338-44	Washer, lock
80	MS35338-45	Washer, lock
81	MS35338-46	Washer, lock
82	MS35338-47	Washer, lock

ITEM #	PART NUMBER	NOMENCLATURE
83	MS35338-48	Washer, lock
84	MS35338-49	Washer, lock
85	MS35338-62	Washer, lock
86	MS35338-63	Washer, lock
87	MS35338-65	Washer, lock
88	MS35340-47	Washer, lock
88.1	MS35744-2	Rivet
89	MS35764-1161	Bolt, self-locking
90	MS35764-1605	Bolt, self-locking
91	MS39086-173	Pin, spring
92	MS45904-72	Washer, lock
93	MS51007-1	Gasket
94	MS51007-9	Gasket
95	MS51848-10	Washer, lock
96	MS51848-12	Washer, lock
97	MS51860-60	Locknut
97.1	MS51922-33	Nut, self-locking
98	MS51922-9	Nut, self-locking
99	MS51943-32	Nut, self-locking
100	MS51997-104P	Ring, serrated lock
101	MS52000-3	Gasket
102	11749502-4	Gasket
103	7388352	Gasket
104	MS9048-107	Pin, spring
105	Deleted	Deleted

## G-3 MANDATORY REPLACEMENT PARTS LIST - CONTINUED

ITEM #	PART NUMBER	NOMENCLATURE
106	QQW461	Lockwire
107	TM706	Washer, lock
108	103485	Rivet
109	10888013-4	Bearing, sleeve
110	10888018	Seal
110.1	10895432	Bearing, sleeve
111	10895523	Shim
111.1	10895585	Gasket
112	10895606	Gasket
113	10895831	Pad, cushioning
114	10895841	Washer, flat
115	10895858	Seal, cover
116	10897684	Seal
117	10897692	Spacer, plate
118	10897823	Seal
119	10897870	Gasket
120	10898017	Shim
121	10925358	Gasket
122	10925359	Felt, mechanical
123	10931213-1	Spacer, plate
124	10931213-2	Spacer, plate
125	10931214-1	Washer, flat
126	10931214-2	Washer, flat



ITEM #	PART NUMBER	NOMENCLATURE
127	10931214-3	Washer, flat
128	10935750-1	Ring, spacer
129	10935750-2	Ring, spacer
130	10935750-3	Ring, spacer
131	10935751-1	Plate, spacer
132	10935751-2	Plate, spacer
133	10935752	Seal, non-metallic
134	10946907-3	Sleeve, wire swaging
135	10953654	Pin, spring
136	10953898	Spacer, plate
137	10954727	Seal
138	10955765	Gasket
139	11593903-1	Gasket
140	11604793	Gasket, cover
141	12Z2007-381	Nut, self-locking
142	12012119	Gasket
142.1	12012124	Pad, cushioning
143	12012146-1	Shims
144	12012146-2	Shims
145	12012146-3	Shims
146	12012146-4	Shims
147	12012147-1	Shims
148	12012147-2	Shims
149	12012147-3	Shims
150	12012147-4	Shims
151	12012277-1	Seal

**G-3 MANDATORY REPLACEMENT PARTS LIST – CONTINUED**

ITEM #	PART NUMBER	NOMENCLATURE
152	12012277-2	Seal
153	12012280	Strip, rubber
154	12012281	Pad, cushioning
155	12012282	Seal
156	12012293	Seal
157	12012296	Strip, rubber
158	12012298	Pad, cushioning
159	12012299	Seal
160	12012319-1	Shims
161	12012319-2	Shims
162	12012319-3	Shims
163	12012320-1	Shims
164	12012320-2	Shims
165	12012320-3	Shims
166	12012360-2	Shims
167	12012360-3	Shims
168	12343072	Gasket
169	12576081	Gasket
170	12576082	Gasket
171	12576083	Gasket
172	12576101	Gasket
172.1	12979826	Gasket
172.2	12910696	Strip

ITEM #	PART NUMBER	NOMENCLATURE
173	142585	Clip, retaining
174	7320655	Gasket
175	7358587	Washer, spring
176	7962242	Seal
177	7962251	Packing, preformed
178	7962254	Seal
179	7972766	Gasket
180	7998737	Gasket
181	8267869	Nut, self-locking
182	8346053	Washer, lock
183	8712289	Nut, self-locking
184	8712289-1	Nut, self-locking
185	8712289-5	Nut, self-locking
186	8712289-7	Nut, self-locking
187	9399028	Kit, hydraulic filter parts
188	9399041-1	Shim
189	9399041-2	Shim



## APPENDIX H TOOL IDENTIFICATION LIST




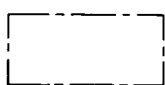





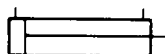
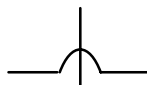









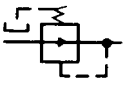










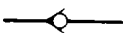
### TOOL IDENTIFICATION LIST

ITEM	LEVEL	NOMENCLATURE	NSN	REFERENCE
1	C,O	Fuzesetter (11747300)	1290-00-078-4367	TM 9-2350-311-10
2	O	Gage, tire pressure (955)	4910-01-117-2994	SC 4910-95-CL-A74
2.1	C,O	Gun tube leveling fixture w/case 11578744	4933-00-340-1129	TM 9-2350-311-10
2.2	C,O	Hose, non-metallic (MIL-H-5593)	4720-00-277-8982	TM 9-2350-311-10
3	O,F	Kit, nitrogen charging (8449334)	1025-01-070-3200	TM 9-2350-311-24P-2
4	O	Kit, purging, fire control	4931-00-065-1110	SC 4931-95-CL-J54
5	O	Lead set, test	6625-00-444-4041	CTA 50-970
6	O	Multimeter, digital (T00377)	6625-01-139-2512	SC 4910-95-CL-A74
7	O	Pail, utility	7240-00-160-0455	TM 9-2350-311-10
8	O	Pan, drain	4910-00-387-9592	SC 4910-95-CL-A74
9	O	Pump kit, hydraulic oil gun recoil, M3 type	4933-00-712-2378	SC 4933-95-CL-A12
10	O	Rivet set, hand (GGG-R-400)	5120-00-017-2849	SC 4933-95-CL-A11
11	O	Shackle, chain (3560-T-45)		
12	O	Soldering gun, electrical (D550-3)	3439-00-618-6623	SC 4910-95-CL-A72
13	O	Soldering torch kit (61112)	3439-00-542-0531	SC 4910-95-CL-A72
14	O	Tool kit, electrical connector repair	5180-00-876-9336	SC 4910-95-CL-A72
15		Wrench, pipe	5120-00-277-1461	SC 4910-95-CL-A72
16	O	Wrench, socket (10930422)	5120-00-976-3105	TM 9-2350-311-24P-2
17	O,F	Wrench, spanner (8769014)	5120-00-946-3750	TM 9-2350-311-10
18	O	Wrench, torque 1/2 dr. 0-175 LB/FT (0-237 N·m) (A-A-2411)	5120-00-640-6364	SC 4910-95-CL-A72



## APPENDIX I HYDRAULIC SCHEMATIC SYMBOLS

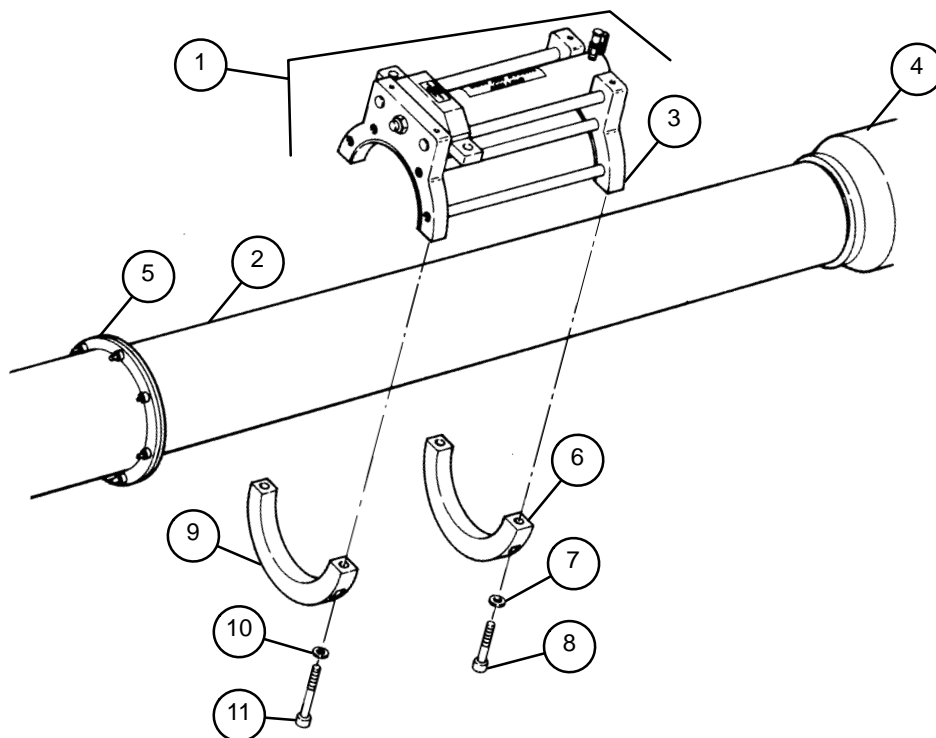
This appendix provides the hydraulic symbols used on the hydraulic schematic drawings.

LINES AND LINE FUNCTIONS		MISCELLANEOUS COMPONENTS	
LINE, WORKING		DIRECTION OF ROTATION (ARROW IN FRONT OF SHAFT)	
LINE, PILOT		COMPONENT ENCLOSURE	
LINE, DRAIN		RESERVOIR, VENTED	
CONNECTOR		PRESSURE GAGE	
LINE, JOINING		CYLINDER, DOUBLE ACTING	
LINE, PASSING		KNOB	
DIRECTION OF FLOW		MANUAL ACTUATOR, SPRING RETURNED	
LINE TO RESERVOIR		SOLENOID	
RESTRICTION, FIXED		COMPONENT PORT	
RESTRICTION, VARIABLE		MOTOR, HYDRAULIC, FIXED DISPLACEMENT	
BASIC VALUE SYMBOLS			
PRESSURE REDUCING VALVE		PUMP, HYDRAULIC, FIXED DISPLACEMENT	
BASIC VALVE ENVELOPE		GAS (NITROGEN) -OVER- HYDRAULIC FLUID ACCUMULATOR	
BASIC VALUE SYMBOL, MULTIPLE FLOW PATHS		SWITCH, PRESSURE	
FLOW PATHS BLOCKED IN CENTER POSITION		FILTER, HYDRAULIC FLUID	
MULTIPLE FLOW PATHS (ARROW SHOWS FLOW DIRECTION)		MOTOR, ELECTRIC	
RELIEF VALVE, SPRING RETURNED		TRAVERSE LEFT	TL
CHECK VALVE		TRAVERSE RIGHT	TR









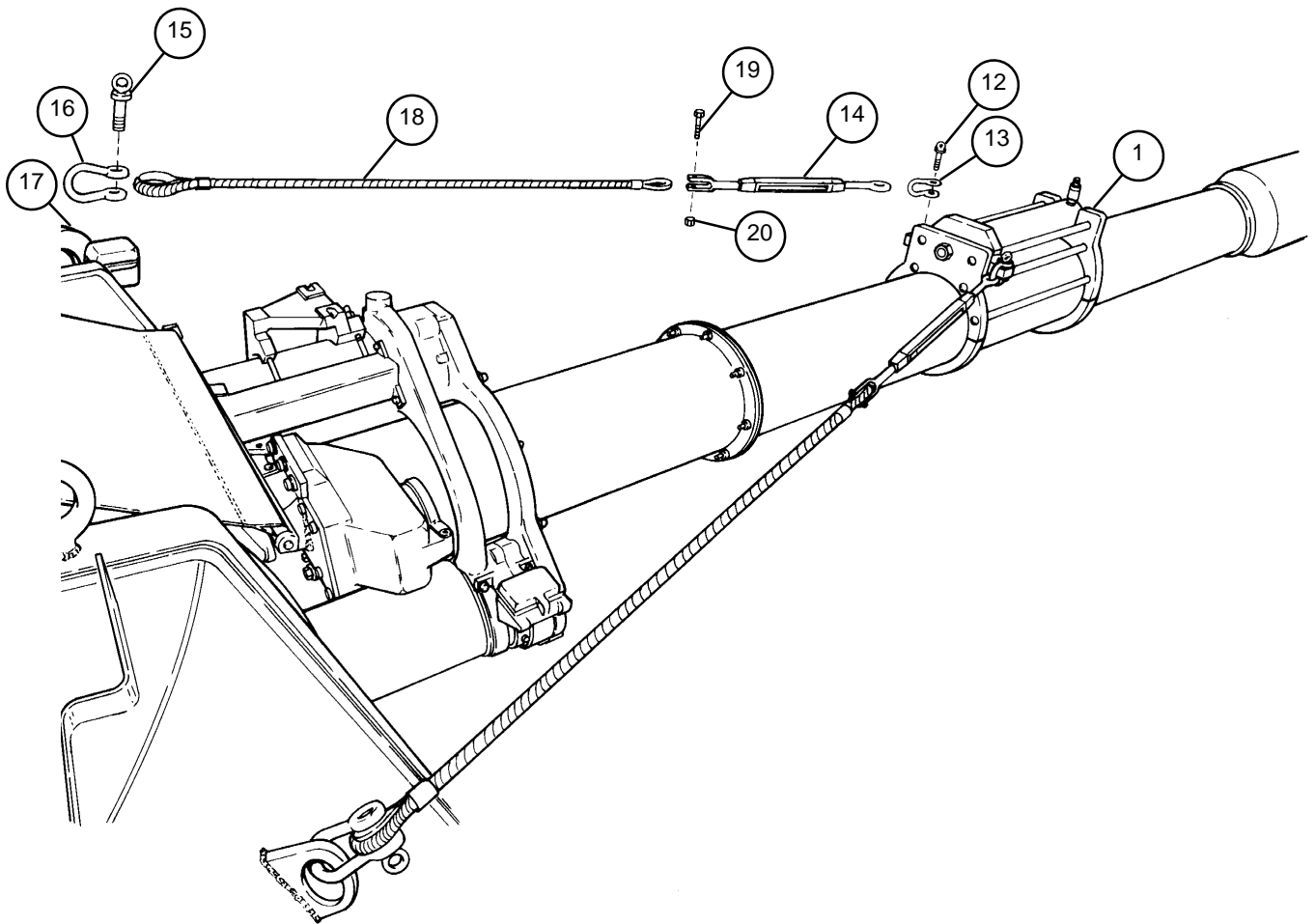
---

**J-1 RECOIL EXERCISER INSTRUCTIONS – CONTINUED**

---

**a. Installation – Continued**

- 5 Remove pin (12) from each of two 5/8" shackles (13). Insert one 5/8" shackle into each of two turnbuckle (14) eyes. Secure 5/8" shackles to cylinder support assembly (1) using two pins.
- 6 Remove pin (15) from each of two 1" shackles (16). Insert one 1" shackle into each of two cab lifting eyes (17). Secure 1" shackle to each of two wire rope assembly (18) thimbles using two pins.
- 7 Remove screw (19) and nut (20) from each of two turnbuckles (14). Insert each turnbuckle into wire rope assembly (18) and secure with screw and nut.
- 8 Adjust two turnbuckles (14) evenly to remove slack from two wire rope assemblies (18).



**NOTE**

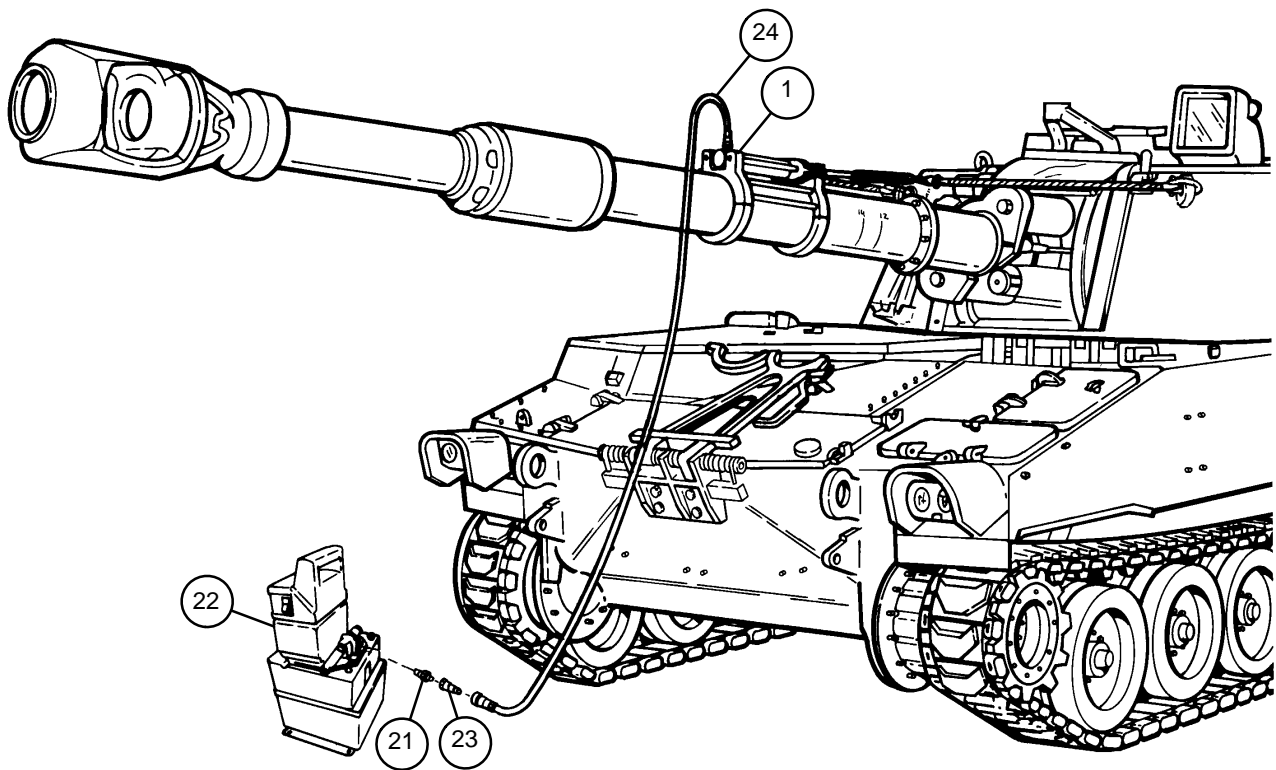
Perform steps 9 and 10 if pipe nipple and quick disconnect coupling have not been installed on pump.

- 9 Apply teflon pipe sealant to threads of pipe nipple (21). Install pipe nipple in outlet port on electric hydraulic pump (22).
- 10 Connect quick disconnect coupling (23) to pipe nipple (21).
- 11 Attach one end of hose assembly (24) to cylinder support assembly (1) and quick disconnect coupling (23).

**NOTE**

Hand pump hydraulic fluid capacity is 2 gallons (7.4 l) Electric hydraulic pump fluid capacity is 3/4 gallon (2.8 l).

- 12 Fill electric hydraulic pump (22) reservoir with hydraulic fluid (item 20.1, Appx D) to the proper level.
- 13 Connect electric hydraulic pump (22) to an electrical power source.



---

**J–1 RECOIL EXERCISER INSTRUCTIONS – CONTINUED**

---

**b. Operation**

- 1 Release cannon tube (2) from travel lock (25) and position cannon tube at the same elevation as when held by travel lock. Stow travel lock.
- 2 Place chalk markings on cannon tube (2) 12 and 14 inches (30.4 and 35.56 cm) from front of dust cover (5).

**CAUTION**

Breech must be closed prior to pumping to prevent damage to operating cam rollers.

- 3 Close breech (26).

**WARNING**

Cylinder support assembly has moving parts. Keep clear of cylinder support assembly during operation to avoid injury.

**NOTE**

- The electric hydraulic pump has a three position REMOTE ON-OFF-MOMENTARY ON switch. To operate the electric hydraulic pump using the remote control, place the REMOTE ON-OFF-MOMENTARY ON switch in the REMOTE ON position. To operate the electric hydraulic pump without the remote control, hold the REMOTE ON-OFF-MOMENTARY ON switch in the MOMENTARY ON position.
  - Make sure quick disconnect couplings are fully seated.
- 4 If using electric hydraulic pump (22), place manual valve (27) in upright position. Using the electric hydraulic pump, begin pumping. During pumping, check for hydraulic leaks. If leaks are found, slowly release hydraulic pressure and replace defective parts.
  - 5 Continue pumping until front of dust cover (5) is between the chalk markings.
  - 6 Inspect buffer piston rod (28) for discoloration. If no discoloration is found, skip to step 9.

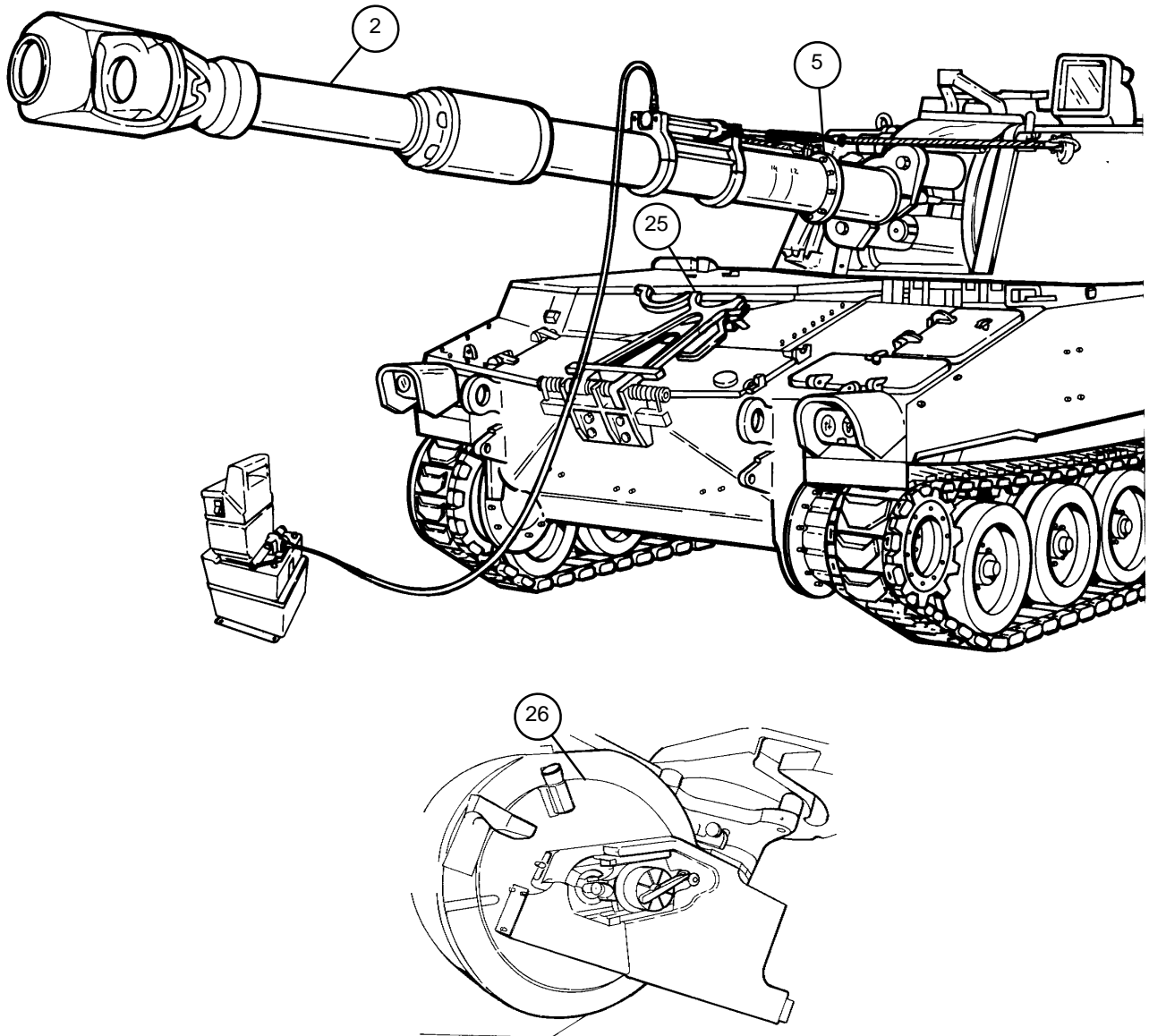
**WARNING**

The cannon tube must be blocked during cleaning to prevent cannon tube from returning to battery resulting in injury to personnel.

**CAUTION**

Do not use abrasives other than crocus cloth when cleaning to prevent damage to the buffer piston rod.

- 7 Block cannon tube (2) while out of battery with a 4"x4"x12" wooden block (29). Hold wooden block in position and slowly release pump pressure until wooden block stops cannon tube movement. Rub crocus cloth soaked with hydraulic fluid (item 21, Appx D) in a longitudinal direction, along the buffer piston rod (28) to remove all discoloration.



---

**J-1 RECOIL EXERCISER INSTRUCTIONS – CONTINUED**

---

**b. Operation. – Continued****WARNING**

Be sure hands, arms, and loose clothing are clear of cannon tube and breech prior to removing the wooden block to prevent injury to personnel.

- 8 If using electric hydraulic pump (22), place manual valve (27) in upright position. Using the electric hydraulic pump, begin pumping to move the cannon tube off of the wooden block. Remove wooden block.
- 9 If using electric hydraulic pump (22), turn manual valve (27). Release hydraulic pressure at the electric hydraulic pump allowing cannon tube (2) to return to battery.
- 10 Repeat steps 3, 4, 5, and 9.
- 11 Repeat steps 3, 4, and 5.

**WARNING**

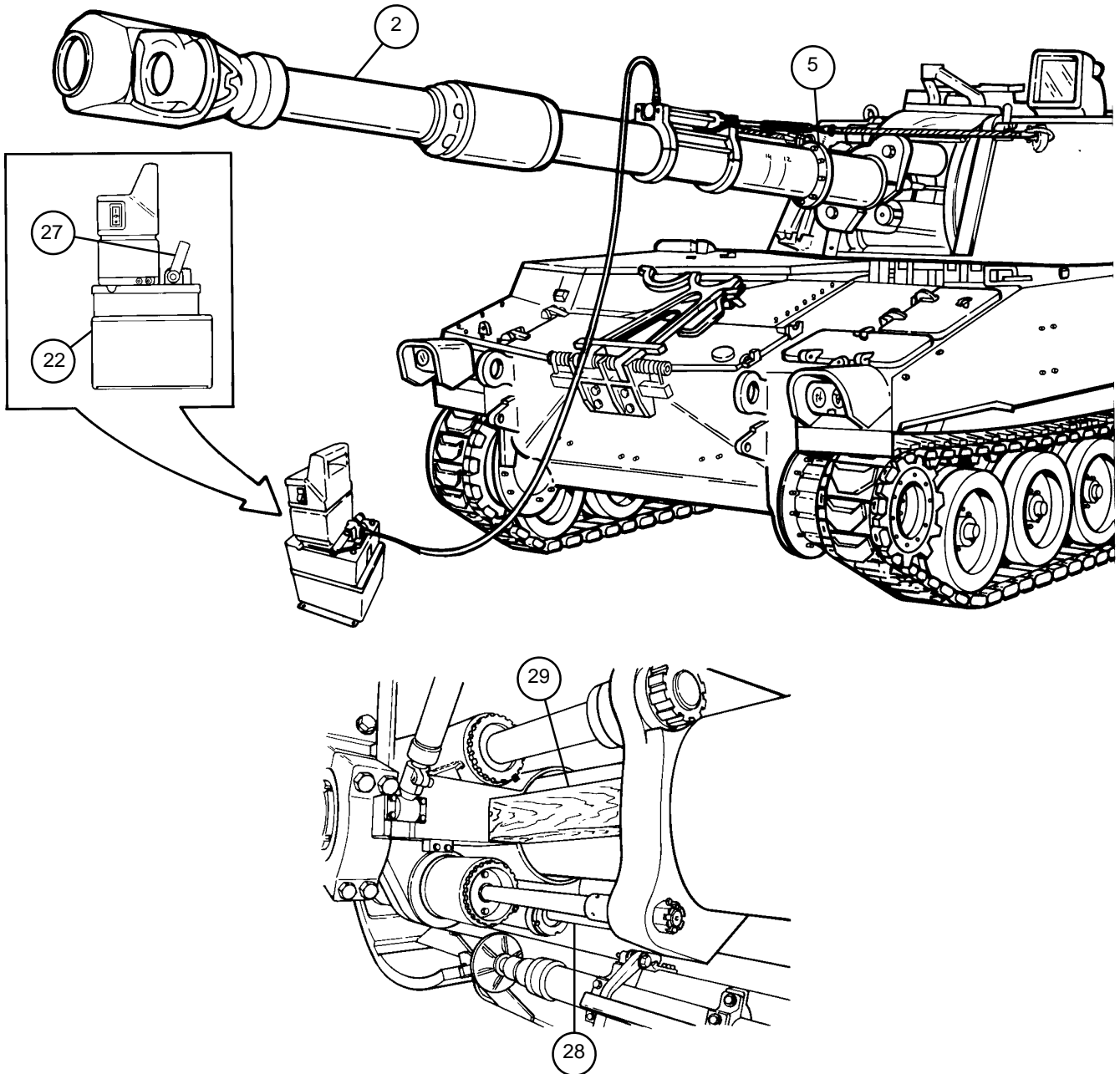
The cannon tube must be blocked while lubricating to prevent cannon tube from returning to battery resulting in injury to personnel.

- 12 Block cannon (2) while out of battery with a 4"x4"x12" wooden block (29). Hold wooden block in position and slowly release pump pressure until wooden block stops cannon tube movement. Coat exposed buffer piston rod (28) surface lightly with hydraulic fluid (item 21, Appx D).

**WARNING**

Be sure hands, arms, and loose clothing are clear of cannon tube and breech prior to removing the wooden block to prevent injury to personnel.

- 13 If using electric hydraulic pump (22), place manual valve (27) in upright position. Using the electric hydraulic pump, begin pumping to move the cannon tube off of the wooden block. Remove wooden block.
- 14 If using electric hydraulic pump (22), turn manual valve (27). Release hydraulic pressure at electric hydraulic pump allowing cannon tube (2) to return to battery.





---

**J-1 RECOIL EXERCISER INSTRUCTIONS – CONTINUED**

---

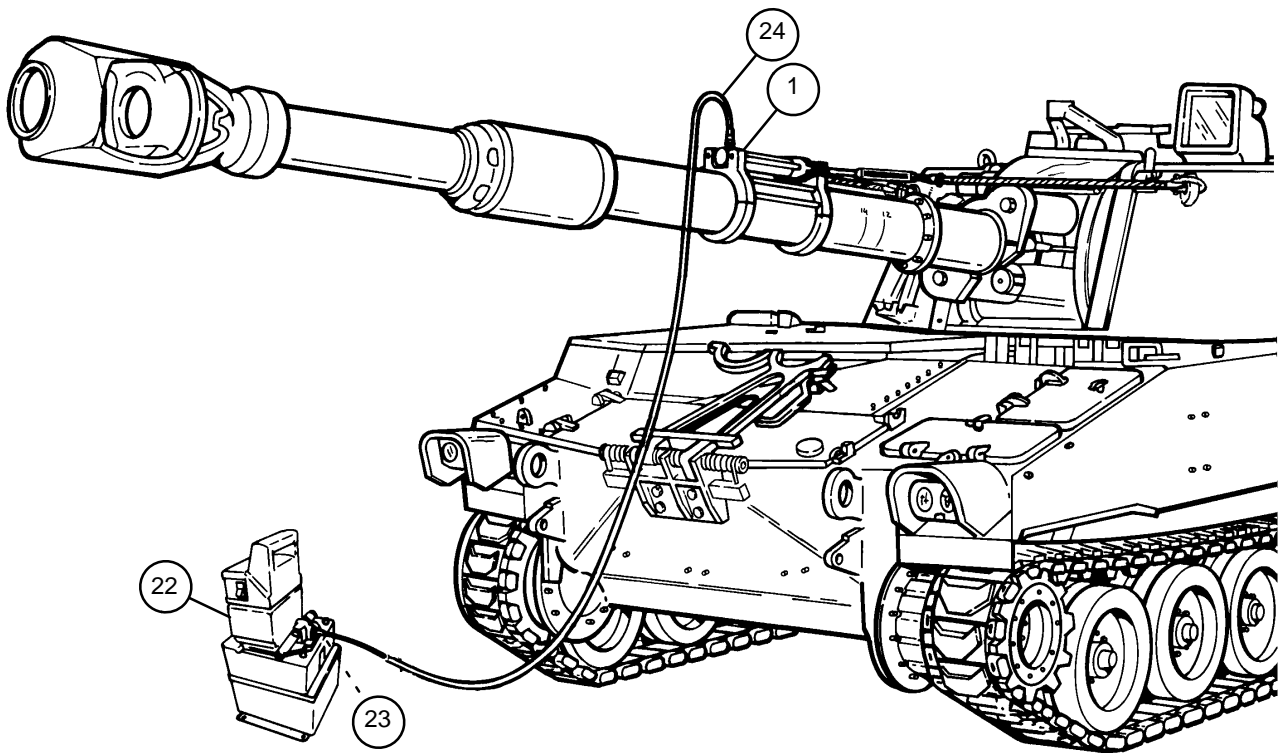
**c. Removal****WARNING**

Ensure all hydraulic pressure has been released before disconnecting hose assembly to avoid injury to personnel.

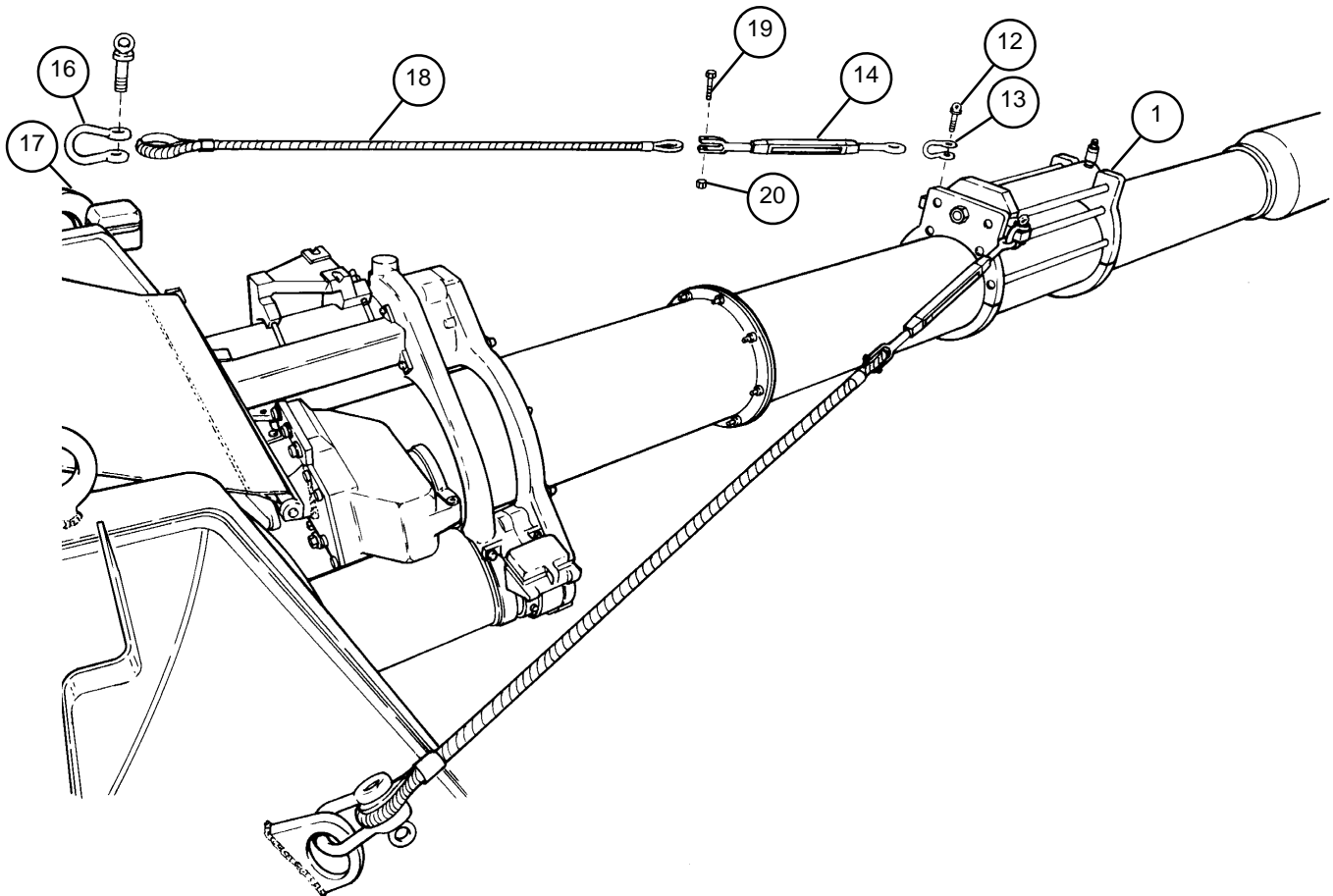
**NOTE**

Before disconnecting hose assembly, place a suitable container below end being disconnected to catch excess hydraulic fluid. Dispose of hydraulic fluid in accordance with local regulations.

- 1 Disconnect hose assembly (25) from cylinder support assembly (1) and quick disconnect coupling (24) on electric hydraulic pump (22).



- 2 Loosen two turnbuckles (14) evenly to release tension on two wire rope assemblies (18).
- 3 Remove screw (19) and nut (20) from each of two turnbuckles (14). Remove two wire rope assemblies (18) from two turnbuckles. Install screw and nut in each of two turnbuckles.
- 4 Remove pin (15) from each of two 1" shackles (16) and remove two wire rope assemblies (18). Remove two 1" shackles from two cab lifting eyes (17). Install pin in each of two 1" shackles.
- 5 Remove pin (12) from each of two 5/8" shackles (13). Remove two 5/8" shackles from cylinder support assembly (1) and remove two turnbuckles (14). Install pin in each of two 5/8" shackles.



---

**J-1 RECOIL EXERCISER INSTRUCTIONS – CONTINUED**

---

**c. Removal – Continued****WARNING**

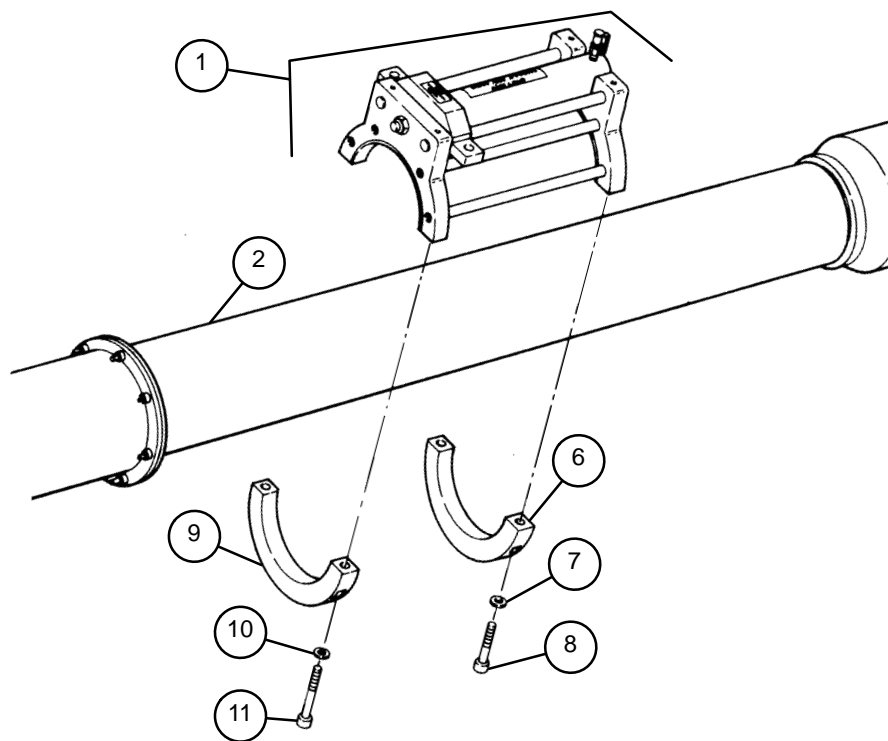
Ensure cylinder support assembly is held in place while the front and rear lower shoes are removed to prevent injury to personnel.

- 6 Remove two screws (11) and two flat washers (10) to remove lower rear shoe (9) from cylinder support assembly (1).
- 7 Remove two screws (8) and two flat washers (7) to remove lower front shoe (6) from cylinder support assembly (1).

**WARNING**

Cylinder support assembly weighs 85.7 pounds (38.87 kg). Two individuals are required to remove cylinder support assembly to prevent injury to personnel.

- 8 Remove cylinder support assembly (1) from cannon tube (2).





## ALPHABETICAL INDEX

Subject	Paragraph
<b>A</b>	
Access cover, cab	14-11
Access cover, cradle and howitzer	5-21
Access cover, M140/M140A1 alinement device mount	5-15
Access cover (M182 mount)	5-18
Access cover, variable recoil	5-13
Accumulator assembly (main)	6-10
Accumulator assembly (manual pump)	6-9
Accumulator assembly (primary)	6-11
Accumulator assembly (secondary)	6-12
Accumulator assembly, replenisher	5-19
Actuating valve	7-4
Adapter arm assembly	12-2
Adding fluid (power pack)	6-2
Adhesives, application of	2-17
Adjuster assembly, seat	13-3
Adjuster leaf spring	5-6
Administrative storage, care of equipment in	2-28
Administrative storage, removal from	2-32
Air heater, M3 electrical	17-2
Air line filter	6-18
Air outlet orifice connector	17-6
Air purifier, M2A2	17-3
Amplifier	8-16
Antenna bracket, radar	5-20
Application of adhesives	2-17
Arm assembly, adapter	12-2
Arm assembly, electrical contact	9-3
Arm clevis assembly, bustle door	14-9
Assembly procedures	2-10
Assistant gunner's control assembly	6-20
Automotive equipment (preparation for shipment)	2-27
Auxiliary equipment	2-25
<b>B</b>	
Ballistic cover, panoramic telescope	2-5.2, Chapter 16
Basic issue items	2-25
Battery computer system mounting brackets	15-10
Battery (pushing cannon out of) (See buffer assembly)	
Bearing protective shields, turret (cab)	4-1
Bearing/race ring assembly	4-2
Bleeding, power pack	6-3
Block assembly, firing	5-5
Blocking	2-36
Bore evacuator	5-1
Box assembly, NBC control	17-4
Box assembly, power relay	8-13
Box assembly, gunner's selector switch	8-12
Boxes, exterior stowage	15-2
Boxes, oddment stowage	15-4
Bracket, M2A2 air purifier	17-3
Bracket and strike assembly, cab bustle door group	14-6
Bracket assembly, cannister stowage	15-12

## ALPHABETICAL INDEX - CONTINUED

**Subject** **Paragraph**

### B - Continued

Bracket assembly, collimator .....	15-5
Bracket assembly, signal flare .....	15-8
Bracket, collimator control .....	15-6
Bracket, radar antenna .....	5-20
Brackets, battery computer system mounting .....	15-10
Breech mechanism .....	3-3
Breechblock assembly .....	5-8
Buffer assembly .....	5-17
Bumper assembly, side doors .....	14-4
Bustle door arm clevis assembly .....	14-9
Bustle door assemblies, left and right .....	14-8
Bustle door group, cab (strike and bracket assemblies) .....	14-6
Bustle door wire rope assemblies, left and right .....	14-10
Bypass valve assembly .....	6-7

### C

Cab access cover .....	14-11
Cab bustle door group (strike and bracket assemblies) .....	14-6
Cable diagram .....	2-5.5
Cable repair .....	8-1
Cable retainer, tow .....	15-11
Cab power lead assembly .....	8-4
Cab side doors, left and right .....	14-5
Cab traversing mechanism harness .....	8-7
Cab weather cover .....	Chapter 10
Caliber .50 machine gun mount support .....	2-5.1
Cam, operating .....	5-12
Cannister stowage bracket assembly .....	15-12
Cannon .....	3-3
Cannon (preparation for shipment) .....	2-27
Cannon (pushing cannon out of battery) (See buffer assembly)	
Care of equipment in administrative storage .....	2-28
Carrier assembly .....	5-9
Charging (power pack) .....	6-3
Checks, rammer reliability .....	7-3
Cleaning .....	2-12
Cleaning, general .....	2-26
Clevis assembly, bustle door arm .....	14-9
Clutch valve .....	6-8
Clutch valve (lines and fittings) .....	6-27
Collar, thrust .....	5-1
Collimator bracket assembly .....	15-5
Collimator control bracket .....	15-6
Commander's seat .....	13-1
Commander's seat assembly (seat parts only) .....	13-2
Common tools and equipment .....	2-1
Components, location and description of major .....	1-14
Connector, air outlet orifice .....	17-6
Contact arm assembly, electrical .....	9-3
Contact assembly, electrical .....	11-3
Contact board segments for 3 contact arm assemblies .....	9-2
Contact board segments for 5 contact arm assemblies .....	9-1
Control assembly, assistant gunner's .....	6-20
Control assembly, gunner's .....	6-19

Subject	Paragraph
Control assembly handles (gunner's/assistant gunner's)	6-21
Control box	8-16
Control box assembly, NBC	17-4
Control bracket, collimator	15-6
Corrosion prevention and control (CPC)	1-10
Cover, access (M182 mount)	5-18
Cover, cab weather	Chapter 10
■ Cover, recuperator	5-16
Cover plate, traversing mechanism	11-2
■ Cradle and howitzer, access covers	5-21
Crowbar stop	15-11
Cupola cover, body, and handle	12-3

**D**

Damper assembly	5-11
Data plates	1-14.4
Decals	2-7
Destruction of Army materiel to prevent enemy use	1-3
Differences between models	1-15
■ Direct fire range plate	5-22
Disassembly procedures	2-10
Discharging hydraulic pressure	6-3
Dome light assemblies	8-11
Door assemblies, left and right bustle	14-8
Door assembly, projectile access	14-7
Door, arm clevis assembly bustle	14-9
Doors, cab side, left and right	14-5
Doors, side, bumper assembly	14-4
Draining fluid (power pack)	6-3
Dust shield	5-13

**E**

Eccentric shaft	18-4
Elbow telescope, M118A2/M118A3	18-2
Electrical air heater, M3	17-2
Electrical connections (preliminary servicing and adjustment of equipment)	2-6.1
Electrical contact assembly	11-3
Electrical contact arm assembly	9-3
Elevating system	1-18.2, 3-3
Elevation control switch lead assembly, gunner's	8-8
Elevation equilibration cylinder (lines and fittings)	6-30
Elevation pump assembly, manual	6-15
Elevation quadrant, M15	18-6
Elevation selector valve assembly	6-16
■ Equilibrated elevation mechanism assembly	6-3.1
Equilibration handpump assembly	6-14
Equilibration manifold assembly	6-13
Equipment characteristics, capabilities, and features	1-13
Equipment configuration	1-17
Equipment data	1-16
Equipment, improvement recommendations (EIR) reporting	1-7
Equipment operation and description	1-18
Escape hatch, gunner's (modified)	14-2
Escape hatch, gunner's (unmodified)	14-1
Evacuator, bore	5-1
■ Exerciser Instruction, recoil	Appendix J
Exercising	2-30
Exercising hydraulic components	2-18
Expendable/durable item list	Appendix D
Exterior stowage boxes	15-2
External major components	1-14.2
External stowage	2-5.3

## ALPHABETICAL INDEX – CONTINUED

Subject	Paragraph
<b>F</b>	
Filling (power pack) . . . . .	6-3
Filter, air line . . . . .	6-18
Filter assembly, hydraulic . . . . .	6-17
Fire control instruments (preparation for shipment) . . . . .	2-27
Fire control (preliminary servicing and adjustment of equipment) . . . . .	2-6.4
■ Fire range plate, direct . . . . .	5-22
Firing block assembly . . . . .	5-5
Firing mechanism assembly, M35 (M185 cannon) . . . . .	5-2
Firing mechanism assembly, M49 (M284 cannon) . . . . .	5-3
Firing mechanism housing . . . . .	5-4
Flare bracket assembly, signal . . . . .	15-8
Flashlight holder . . . . .	15-7
Fluid and pressure checks (preliminary servicing and adjustment of equipment) . . . . .	2-6.2
Follower assembly . . . . .	5-5
Forms, maintenance . . . . .	1-2
<b>G</b>	
Gage assembly, sight . . . . .	6-1
Ground lead, NBC . . . . .	8-10
Gun trunnion, leveling . . . . .	18-4
Gunner's/assistant gunner's control assembly handles . . . . .	6-21
Gunner's control assembly . . . . .	6-19
Gunner's control assembly, assistant . . . . .	6-20
Gunner's elevation control switch lead assembly . . . . .	8-8
Gunner's escape hatch (modified) . . . . .	14-2
Gunner's escape hatch (unmodified) . . . . .	14-1
Gunner's selector switch box assembly . . . . .	8-12
Gunner's selector switch box wiring harness . . . . .	8-2
<b>H</b>	
Handle assembly (See carrier assembly)	
■ Handles . . . . .	15-14
Handles, gunner's/assistant gunner's control assembly . . . . .	6-21
Handpump assembly, equilibration . . . . .	6-14
Handwheel assembly . . . . .	11-4
Harness, cab traversing mechanism . . . . .	8-7
Heater, M3 electrical air . . . . .	17-2
Holder, flashlight . . . . .	15-7
Hoses and fittings (NBC) . . . . .	17-5
Housing, firing mechanism . . . . .	5-4
Hydraulic filter assembly . . . . .	6-17
Hydraulic filter (lines and fittings) . . . . .	6-24
Hydraulic pressure, discharging . . . . .	6-3
Hydraulic pressure switch . . . . .	6-6
Hydraulic schematic symbols . . . . .	Appendix I
Hydraulic system, cab . . . . .	3-3
Hydraulics, cab (preliminary servicing and adjustment of equipment) . . . . .	2-6.3
Hygrosopic breather . . . . .	6-18
<b>I</b>	
Inspection (administrative storage) . . . . .	2-29
Inspection procedures, general . . . . .	2-13
■ Instruction, recoil exerciser . . . . .	Appendix J
Instruction signs . . . . .	2-7
Intercom power system wiring harness . . . . .	8-15



<b>Subject</b>	<b>Paragraph</b>
Intercommunication system .....	3-3
Internal major components .....	1-14.1
Internal stowage .....	2-5.4
<b>L</b>	
Labels .....	2-7
Latch assembly, side doors .....	14-3
Lead assembly, cab power .....	8-4
Lead assembly, gunner's elevation control switch .....	8-8
Lead assembly, NBC power .....	8-9
Lead assembly, panoramic telescope to dome light .....	8-3
Lead assembly, power relay box to intercom power supply .....	8-14
Lead assembly, power relay box to pump motor .....	8-5
Lead, NBC ground .....	8-10
Leaf spring, adjuster .....	5-6
Leakage definitions .....	2-8.5
Leveling gun trunnions .....	18-4
Light assemblies, dome .....	8-11
Lighting system, cab .....	3-3
Lines and fittings from cab to power pack .....	6-23
Lines and fittings from clutch valve .....	6-27
Lines and fittings from elevation equilibration cylinder .....	6-30
Lines and fittings from elevation selector valve assembly .....	6-29
Lines and fittings from hydraulic filters .....	6-24
Lines and fittings from manual accumulator assembly .....	6-28
Lines and fittings from power pack to pressure switch and gages .....	6-22
Lines and fittings from primary and secondary accumulators to equilibrated elevating cylinder .....	6-25
Lines and fittings from traversing mechanism .....	6-26
Lines and fittings, rammer .....	7-1
Linkage assembly .....	18-4
Link connector .....	18-4
Loading vehicle for shipment .....	2-35
Location and description of major components .....	1-14
Lock assembly, turret .....	11-1
Lubricants and military symbols .....	2-8.4
Lubrication .....	2-8
Lubrication intervals .....	2-8.2
Lubrication (preliminary servicing and adjustment of equipment) .....	2-6.5
<b>M</b>	
M2A2 air purifier and bracket .....	17-3
M3 electrical air heater .....	17-2
M15 elevation quadrant .....	18-6
M27 periscope stowage box .....	15-3
M35 firing mechanism assembly (M185 cannon) .....	5-2
M42 periscope cover door .....	5-14
M42 tank periscope .....	18-7
M49 firing mechanism assembly (M284 cannon) .....	5-3
M117/M117A2 panoramic telescope .....	18-5
M118A2/M118A3 elbow telescope .....	18-2
M140 alinement device mount access cover .....	5-15
M145/M145A1 telescope mount .....	18-3
M145/M145A1 telescope mount: synchronization and adjustment .....	18-4
M146 telescope mount .....	18-1
M182 mount access cover .....	5-18
Machine gun mount support .....	12-1
Main accumulator assembly .....	6-10
Maintenance allocation chart (MAC) .....	Appendix B

## ALPHABETICAL INDEX – CONTINUED

Subject	Paragraph
<b>M – Continued</b>	
Maintenance forms, records, and reports	1-2
Manifold assembly, equilibration	6-13
Manual elevation pump assembly	6-15
Manual pump accumulator assembly	6-9
Mandatory replacement parts list	Appendix G
Manufactured items list	Appendix E
Mount, M145/M145A1 telescope	18-3
Mount, M145/M145A1 telescope (synchronization and adjustment)	18-4
Mount, M146 telescope	18-1
Mount access cover, M182	5-18
Mount and howitzer assembly	1-18.1
Mount support, machine gun	12-1
Mounting brackets, battery computer system	15-10
<b>N</b>	
NBC control box assembly	17-4
NBC ground lead	8-10
NBC power lead assembly	8-9
NBC system circuit (M109A4/M109A5)	3-3
NBC system (M109A4/M109A5)	1-18.5
NBC system inspection and repair	17-1
Nomenclature cross-reference list	1-6
Nuclear hardness	1-11
<b>O</b>	
Oddment stowage boxes	15-4
Official nomenclature, names, and designations	1-6
Operating cam	5-12
Operating crank assembly (See carrier assembly)	
<b>P</b>	
Painting, general	2-26
Panoramic telescope, M117/M117A2	18-5
Panoramic telescope to dome light lead assembly	8-3
Panoramic telescope ballistic cover	2-5.2, Chapter 16
Periscope cover door, M42	5-14
Periscope, M42 tank	18-7
Periscope stowage box, M27	15-3
Plate, direct fire range	5-22
Plate, traversing mechanism cover	11-2
PMCS (Preventive maintenance checks and services)	2-9
Power lead assembly, cab	8-4
Power lead assembly, NBC	8-9
Power pack, hydraulic (draining, filling and charging)	6-3
Power pack, hydraulic (fluid level)	6-2
Power pack solenoid	6-5
Power pack strainer	6-4
Power relay box assembly	8-13
Power relay box to intercom power supply lead assembly	8-14
Power relay box to pressure switch wiring harness	8-6
Power relay box to pump motor lead assembly	8-5
Power system, cab	3-3
Power system wiring harness (intercom)	8-15
Preliminary requirements (preparation for storage or shipment)	2-20

<b>Subject</b>	<b>Paragraph</b>
Preliminary servicing and adjustment of equipment .....	2-6
Preparation for storage or shipment .....	1-4
Preparation of cannon, fire control instruments, and automotive equipment (for shipment) .....	2-27
Pressure switch, hydraulic .....	6-6
Pre-troubleshooting procedures (TM 9-2350-311-10) .....	3-1.1
Preventive maintenance checks and services (PMCS) .....	2-9
Primary accumulator assembly .....	6-11
Projectile access door assembly .....	14-7
Protective shields, turret (cab) bearing .....	4-1
Pump assembly, manual elevation .....	6-15
<b>Q</b>	
Quadrant, M15 elevation .....	18-6
Quality assurance (QA) .....	1-5
Quick guide to troubleshooting .....	3-2
<b>R</b>	
Race ring assembly, bearing .....	4-2
Rack support (collimator bracket assembly) .....	15-5
Radar antenna bracket .....	5-20
Rammer assembly .....	7-2
Rammer hydraulic system .....	3-3
Rammer lines and fittings .....	7-1
Rammer reliability checks .....	7-3
■ Range plate, direct fire .....	5-22
Rear stowage racks .....	15-13
Receipt for storage .....	2-21
■ Recoil exerciser instructions .....	Appendix J
Records, maintenance .....	1-2
Recuperator assembly .....	19-2
Recuperator cover gasket .....	5-16
References .....	Appendix A
Reliability checks, rammer .....	7-3
Removal from administrative storage .....	2-32
Repair parts .....	2-3
Repair parts and special tools list .....	Appendix C
Repair practices, general .....	2-14
Replacement of parts .....	2-11
Replenisher accumulator assembly .....	5-19
Reporting equipment improvement recommendations (EIR) .....	1-7
Reports, maintenance .....	1-2
Retainer assembly .....	15-1
Rifle clip .....	15-9
Ring assembly, bearing/race .....	4-2
Rotation .....	2-31
<b>S</b>	
Safety, care, and handling .....	1-9
Schematic symbols, hydraulic .....	Appendix I
Seat adjuster assembly .....	13-3
Seat assembly, commander's (seat parts only) .....	13-2
Seat, commander's .....	13-1
Secondary accumulator assembly .....	6-12
Security .....	2-22
Security measures for electronic data .....	1-12
Selector switch box assembly, gunner's .....	8-12
Selector valve assembly, elevation .....	6-16
Selector valve assembly, elevation (lines and fittings) .....	6-29
Serial number locations .....	1-14.3
Service upon receipt of material .....	2-4
Servicing .....	2-33
Shield, dust .....	5-13

## ALPHABETICAL INDEX – CONTINUED

**Subject** **Paragraph**

### S – Continued

Shields, turret (cab) bearing protective .....	4-1
Shipment (preparation) .....	1-4
Shipping preparation .....	2-34
Side doors, bumper assembly .....	14-4
Side doors, latch assembly .....	14-3
Sight gage assembly .....	6-1
Signal flare bracket assembly .....	15-8
Soldering .....	2-16
Solenoid, power pack .....	6-5
Special tools, TMDE, and support equipment .....	2-2
Spindle assembly .....	5-7
Spring, adjuster leaf .....	5-6
Stencils .....	1-14.5
Stop, crowbar .....	15-11
Storage plan .....	2-24
Storage (preparation) .....	1-4
Storage receipt .....	2-21
Storage site .....	2-23
Stowage box, M27 periscope .....	15-3
Stowage boxes, exterior .....	15-2
Stowage boxes, oddment .....	15-4
Stowage bracket assembly, cannister .....	15-12
Stowage, external .....	2-5.3
Stowage, internal .....	2-5.4
Stowage racks, rear .....	15-13
Strainer, power pack .....	6-4
Strike and bracket assemblies, cab bustle door group .....	14-6
Support post group .....	13-1
Support, rack (collimator bracket assembly) .....	15-5
Synchronization and adjustment of M145/M145A1 telescope mount .....	18-4

### T

Tank, M42 periscope .....	18-7
Telescope, M117/M117A2 panoramic .....	18-5
Telescope, M118A2/M118A3 elbow .....	18-2
Telescope mount, M145/M145A1 .....	18-3
Telescope mount, M145/M145A1 (synchronization and adjustment) .....	18-4
Telescope mount, M146 .....	18-1
Thrust collar .....	5-1
Tool identification list .....	Appendix H
Torque key .....	5-10
Torque limits .....	Appendix F
Tow cable retainer .....	15-11
Traversing mechanism cover plate .....	11-2
Traversing mechanism harness, cab .....	8-7
Traversing mechanism (lines and fittings) .....	6-26
Traversing system, cab .....	1-18.4, 3-3
Troubleshooting chart .....	3-3
Troubleshooting procedures, general .....	3-2.2
Troubleshooting task initial setup .....	3-1.2
Trunnion, gun (leveling) .....	18-4
Turret (cab) bearing protective shields .....	4-1
Turret lock assembly .....	11-1

Subject	Paragraph
<b>U</b>	
Unpacked equipment, checking .....	2-4.3
Unpacked equipment, processing .....	2-4.4
Unpacking .....	2-4.1
<b>V</b>	
Valve, actuating .....	7-4
Valve assembly, bypass .....	6-7
Valve assembly, elevation selector .....	6-16
Valve, clutch .....	6-8
Variable recoil access cover .....	5-13
<b>W</b>	
Warranty information .....	1-8
Weather cover, cab .....	Chapter 10
Welding .....	2-15
Wire rope assemblies, bustle door, left and right .....	14-10
Wiring harness repair .....	8-1
Wiring harness	
Cab traversing mechanism .....	8-7
Gunner's selector switch box .....	8-2
Intercom power system .....	8-15
Power relay box to pressure switch .....	8-6



<b>RECOMMENDED CHANGES TO PUBLICATIONS AND BLANK FORMS</b> For use of this form, see AR 25-30; the proponent agency is ODISC4.					Use Part II (reverse) for Repair Parts and Special Tools Lists (RPSTL) and Supply Catalogs/Supply Manuals (SC/SM).	Date
TO: (Forward to proponent of publication or form) (Include ZIP Code)					FROM: (Activity and location) (include ZIP code)	
<b>PART I - ALL PUBLICATIONS (EXCEPT RPSTL AND SC/SM) AND BLANK FORMS</b>						
PUBLICATION/FORM NUMBER TM 9-2350-311-20-2				DATE 24 December 1993		TITLE UNIT MAINTENANCE MANUAL FOR M109A2/M109A3/M109A4/M109A5 SELF-PROPELLED HOWITZER 155MM
ITEM	PAGE	PARA	LINE	FIGURE NO.	TABLE	RECOMMENDED CHANGES AND REASON
	7-43					Item 3 calls for 18 washers, 8 of which are used on the M109A2 only. This should read 10 washers and the other 8 should be indicated as for the M109A2 only.
*Reference to line numbers within the paragraph or subparagraph.						
TYPED NAME, GRADE OR TITLE J./ JONES, S SGT, 555-1415				TELEPHONE EXCHANGE/AUTOVON, PLUS EXTENSION		SIGNATURE <i>J Jones</i>

TO: <i>(Forward direct to addressee listed in publication)</i>	FROM: <i>(Activity and location) (Include Zip Code)</i>	DATE
--	---	------

**PART II - REPAIR PARTS AND SPECIAL TOOL LISTS AND SUPPLY CATALOGS/SUPPLY MANUALS**

PUBLICATION NUMBER				DATE			TITLE	
PAGE NO.	COLM NO.	LINE NO.	NATIONAL STOCK NUMBER	REFERENCE NO.	FIGURE NO.	ITEM NO.	TOTAL NO. OF MAJOR ITEMS SUPPORTED	RECOMMENDED ACTION

**PART III - REMARKS** *(Any general remarks or recommendations, or suggestions for improvement of publications and blank forms. Additional blank sheets may be used if more space is needed.)*

TYPED NAME, GRADE OR TITLE	TELEPHONE EXCHANGE/AUTOVON, PLUS EXTENSION	SIGNATURE
----------------------------	--	-----------



<b>RECOMMENDED CHANGES TO PUBLICATIONS AND BLANK FORMS</b> For use of this form, see AR 25-30; the proponent agency is ODISC4.	Use Part II (reverse) for Repair Parts and Special Tools Lists (RPSTL) and Supply Catalogs/Supply Manuals (SC/SM).	Date
---	--	------

<b>TO:</b> (Forward to proponent of publication or form) (Include ZIP Code)	<b>FROM:</b> (Activity and location) (include ZIP code)
---	---

**PART I – ALL PUBLICATIONS (EXCEPT RPSTL AND SC/SM) AND BLANK FORMS**

PUBLICATION/FORM NUMBER TM 9-2350-311-20-2	DATE 24 December 1993	TITLE UNIT MAINTENANCE MANUAL FOR M109A2/M109A3/M109A4/M109A5 SELF-PROPELLED HOWITZER 155MM
---	--------------------------	---

ITEM	PAGE	PARA	LINE	FIGURE NO.	TABLE	RECOMMENDED CHANGES AND REASON

*\*Reference to line numbers within the paragraph or subparagraph.*

TYPED, GRADE OR TITLE	TELEPHONE EXCHANGE/AUTOVON, PLUS EXTENSION	SIGNATURE
-----------------------	--	-----------

TO: <i>(Forward direct to addressee listed in publication)</i>	FROM: <i>(Activity and location) (Include Zip Code)</i>	DATE
--	---	------

PART II - REPAIR PARTS AND SPECIAL TOOL LISTS AND SUPPLY CATALOGS/SUPPLY MANUALS

PUBLICATION NUMBER TM 9-2350-311-20-2	DATE 24 December 1993	TITLE UNIT MAINTENANCE MANUAL FOR M109A2/M109A3/M109A4/M109A5 SELF-PRO- PELLED HOWITZER 155MM
--	--------------------------	--

PAGE NO.	COLM NO.	LINE NO.	NATIONAL STOCK NUMBER	REFERENCE NO.	FIGURE NO.	ITEM NO.	TOTAL NO. OF MAJOR ITEMS SUPPORTED	RECOMMENDED ACTION

PART III - REMARKS *(Any general remarks or recommendations, or suggestions for improvement of publications and blank forms. Additional blank sheets may be used if more space is needed.)*

TYPED NAME, GRADE OR TITLE	TELEPHONE EXCHANGE/AUTOVON, PLUS EXTENSION	SIGNATURE
----------------------------	--	-----------

# THE METRIC SYSTEM AND EQUIVALENTS

## LINEAR MEASURE

1 Centimeter = 10 Millimeters = 0.01 Meters = 0.3937 Inches  
 1 Meter = 100 Centimeters = 1000 Millimeters = 39.37 Inches  
 1 Kilometer = 1000 Meters = 0.621 Miles

## WEIGHTS

1 Gram = 0.001 Kilograms = 1000 Milligrams = 0.035 Ounces  
 1 Kilogram = 1000 Grams = 2.2 Lb.  
 1 Metric Ton = 1000 Kilograms = 1 Megagram = 1.1 Short Tons

## LIQUID MEASURE

1 Milliliter = 0.001 Liters = 0.0338 Fluid Ounces  
 1 Liter = 1000 Milliliters = 33.82 Fluid Ounces

## SQUARE MEASURE

1 Sq. Centimeter = 100 Sq. Millimeters = 0.155 Sq. Inches  
 1 Sq. Meter = 10,000 Sq. Centimeters = 10.76 Sq. Feet  
 1 Sq. Kilometer = 1,000 Sq. Meters = 0.386 Sq. Miles

## CUBIC MEASURE

1 Cu. Centimeter = 1000 Cu. Millimeters = 0.06 Cu. Inches  
 1 Cu. Meter = 1,000,000 Cu. Centimeters = 35.31 Cu. Feet

## TEMPERATURE

$5/9 (^{\circ}\text{F} - 32) = ^{\circ}\text{C}$   
 212° Fahrenheit is equivalent to 100° Celsius  
 90° Fahrenheit is equivalent to 32.2° Celsius  
 32° Fahrenheit is equivalent to 0° Celsius  
 $(9/5 \times ^{\circ}\text{C}) + 32 = ^{\circ}\text{F}$

## APPROXIMATE CONVERSION FACTORS

TO CHANGE	TO	MULTIPLY BY
Inches	Centimeters	2.540
Feet	Meters	0.305
Yards	Meters	0.914
Miles	Kilometers	1.609
Square Inches	Square Centimeters	6.451
Square Feet	Square Meters	0.093
Square Yards	Square Meters	0.836
Square Miles	Square Kilometers	2.590
Acres	Square Hectometers	0.405
Cubic Feet	Cubic Meters	0.028
Cubic Yards	Cubic Meters	0.765
Fluid Ounces	Milliliters	29.573
Pints	Liters	0.473
Quarts	Liters	0.946
Gallons	Liters	3.785
Ounces	Grams	28.349
Pounds	Kilograms	0.454
Short Tons	Metric Tons	0.907
Pound-Feet	Newton-Meters	1.356
Pounds per Square Inch	Kilopascals	6.895
Miles per Gallon	Kilometers per Liter	0.425
Miles per Hour	Kilometers per Hour	1.609

TO CHANGE	TO	MULTIPLY BY
Centimeters	Inches	0.394
Meters	Feet	3.280
Meters	Yards	1.094
Kilometers	Miles	0.621
Square Centimeters	Square Inches	0.155
Square Meters	Square Feet	10.764
Square Meters	Square Yards	1.196
Square Kilometers	Square Miles	0.386
Square Hectometers	Acres	2.471
Cubic Meters	Cubic Feet	35.315
Cubic Meters	Cubic Yards	1.308
Milliliters	Fluid Ounces	0.034
Liters	Pints	2.113
Liters	Quarts	1.057
Liters	Gallons	0.264
Grams	Ounces	0.035
Kilograms	Pounds	2.205
Metric Tons	Short Tons	1.102
Newton-Meters	Pound-Feet	0.738
Kilopascals	Pounds per Square Inch	0.145
Kilometers per Liter	Miles per Gallon	2.354
Kilometers per Hour	Miles per Hour	0.621

